

PROPER USE GUIDELINES

Cumulative Trauma Disorders can result from the prolonged use of manually powered hand tools. AMP hand tools are intended for occasional use and low volume applications. AMP offers a wide selection of powered application equipment for extended-use, production operations.

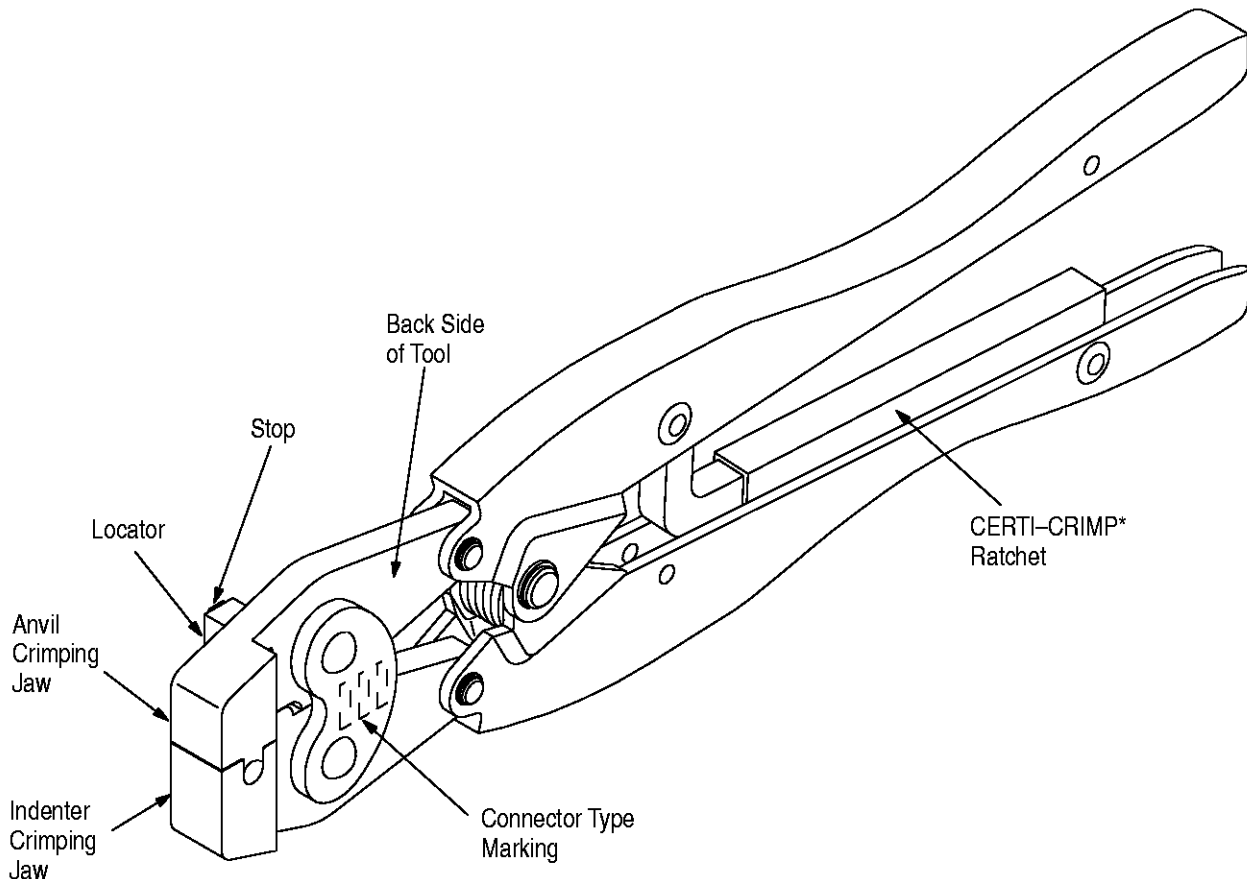

Figure 1

1. INTRODUCTION

AMP* Hand Crimping Tools 69477-4, 220009-1, 220009-5, 220187-1, and 220187-2 are designed to crimp AMP 50-Ohm BNC Connectors 225395-[], 227079-[], and 331350-[] onto a variety of cable sizes and types. AMP Catalog 82074 provides a guide for cable-to-connector selection. For cable sizes and connectors not referenced in the catalog, contact AMP Product Engineering for connector recommendations. Read these instructions thoroughly before using the tool.

NOTE

Dimensions are in millimeters [followed by inch equivalent in brackets]. Figures and illustrations are for identification only and are not drawn to scale.

Reasons for reissue are provided in Section 6, REVISION SUMMARY.

2. DESCRIPTION

Each hand tool features two crimping jaws: an indenter jaw and an anvil jaw, a locator with a stop, and a CERTI-CRIMP ratchet. When closed, the jaws form two crimping chambers. The locator aids in positioning the center contact in the crimping chamber and the stop limits the insertion depth. The connector type is marked on the BACK side of the tool. See Figure 1.

The CERTI-CRIMP ratchet ensures full crimping of the connector. Once engaged, the ratchet will not release until the handles have been FULLY closed.

CAUTION

The crimping jaws bottom before the CERTI-CRIMP ratchet releases. This is a design feature that ensures maximum electrical and tensile performance of the crimp. Do NOT re-adjust the ratchet.

3. CRIMPING PROCEDURE

3.1. Crimping the Center Contact

1. Slide ferrule onto cable, then strip cable according to the dimensions on the instruction sheet supplied with the connector. Do NOT nick or cut cable braid.

NOTE

For cables with air core dielectric, a spacer must be assembled over the center conductor and bottomed against the dielectric prior to assembly of the center contact. If tubing is provided with the connector, slide it over the dielectric prior to assembly. Refer Figure 2.

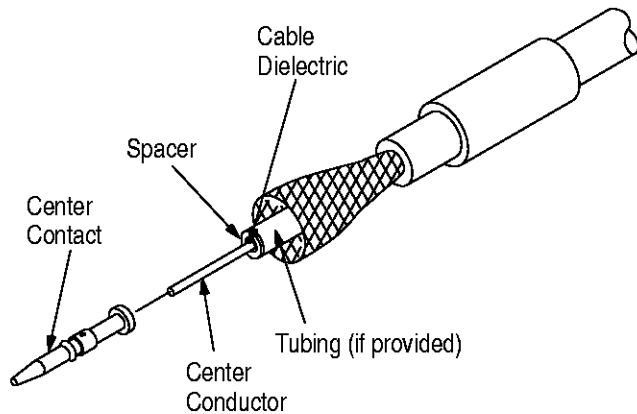

Figure 2

2. Insert cable center conductor into center contact. The contact must be positioned against the cable dielectric.
3. Hold tool so that the BACK side faces you.
4. Insert center contact into tool locator until it butts against the stop. See Figure 3.

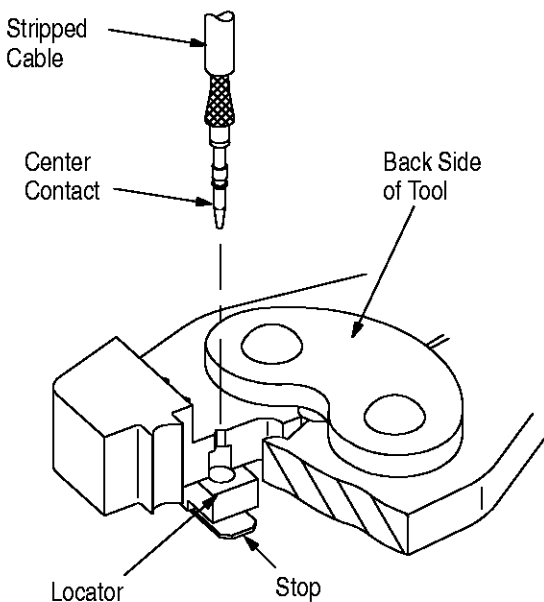

Figure 3

5. Close tool handles just enough to hold contact in place without deforming wire barrel. Make sure that the cable center conductor has not shifted position.

6. Squeeze tool handles until ratchet releases. Allow tool handles to open FULLY.

7. Remove crimped center contact from tool.

3.2. Crimping the Ferrule

1. Flare cable braid to fit over connector support sleeve.

2. Insert crimped center contact into connector until it snaps into place. The cable braid must be positioned over the connector support sleeve. Pull back gently on the cable to ensure that the contact is held in place by the internal locking feature. See Figure 4.

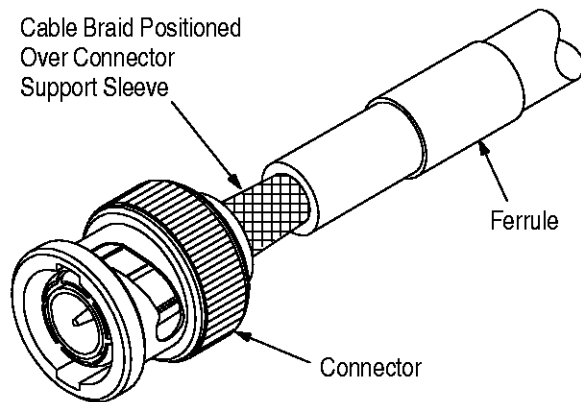

Figure 4

3. Slide ferrule over cable braid until it is positioned against the shoulder of the connector.

4. Position ferrule in crimping chamber on the indenter crimping jaw so that the connector shoulder butts against jaw, as shown in Figure 5.

5. Holding ferrule in position, close tool handles until ratchet releases. Allow tool handles to open FULLY.

6. Remove crimped assembly from tool.

4. MAINTENANCE AND INSPECTION PROCEDURE

AMP recommends that a maintenance and inspection program be performed periodically to ensure dependable and uniform terminations. Though recommendations call for at least one inspection a month, frequency of inspection depends on:

1. The care, amount of use, and handling of the hand tool.

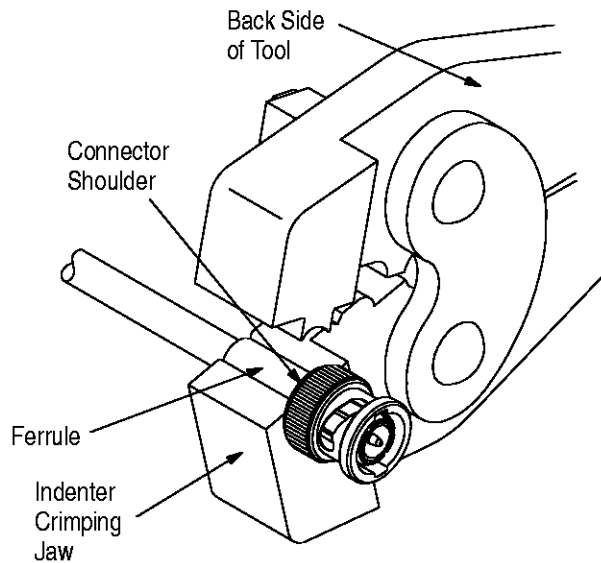

Figure 5

2. The presence of abnormal amounts of dust and dirt.
3. The degree of operator skill.
4. Your own established standards.

The hand tool is inspected before being shipped; however, AMP recommends that the tool be inspected immediately upon arrival to ensure that the tool has not been damaged during shipment.

4.1. Daily Maintenance

1. Hand tool should be immersed (handles partially closed) in a reliable commercial degreasing compound to remove accumulated dirt, grease, and foreign matter. When degreasing compound is not available, tool may be wiped clean with a soft, lint-free cloth. Do NOT use hard or abrasive objects that could damage the tool.
2. Make certain that the retaining pins are in place and that they are secured with retaining rings.
3. All pins, pivot points, and bearing surfaces should be protected with a THIN coat of any good SAE 20 motor oil. Do not oil excessively.
4. When the tool is not in use, keep handles closed to prevent objects from becoming lodged in the crimping jaws. Store the tool in a clean, dry area.

4.2. Periodic Inspection

A. Lubrication

Lubricate all pins, pivot points, and bearing surfaces with SAE 20 motor oil as follows:

Tools used in daily production – lubricate daily
 Tools used daily (occasional) – lubricate weekly
 Tools used weekly – lubricate monthly

Wipe excess oil from tool, particularly from crimping area. Oil transferred from the crimping area onto certain terminations may affect the electrical characteristics of an application.

B. Visual Inspection

1. Close tool handles until ratchet releases and then allow them to open freely. If they do not open quickly and fully, the spring is defective and must be replaced. See Section 5, REPLACEMENT AND REPAIR.
2. Inspect head assembly for worn, cracked, or broken jaws. If damage is evident, return the tool to AMP for evaluation and repair. See Section 5, REPLACEMENT AND REPAIR.

C. Gaging the Crimping Chamber

This inspection requires the use of a plug gage conforming to the diameters in Figure 6. AMP does not manufacture or market these gages. Proceed as follows:

1. Remove traces of oil or dirt from crimping chamber and plug gage.
2. Close the tool handles until it is evident that the jaws have bottomed, then HOLD in this position. Do NOT force the jaws beyond initial contact.
3. Align the GO element with the crimping chamber. Push element straight into the crimping chamber without using force. The GO element must pass completely through. Refer to Figure 6.
4. Now align the NO-GO element and try to insert it straight into the same crimping chamber. The NO-GO element may start entry but must not pass completely through as shown in Figure 6.

If the crimping chamber conforms to the gage inspection, they are considered dimensionally correct and should be lubricated with a THIN coat of any good SAE 20 motor oil. If not, the tool must be repaired before returning it to service. See Section 5, REPLACEMENT AND REPAIR.

For additional information concerning the use of the plug gage, refer to AMP instruction sheet 408-7424.

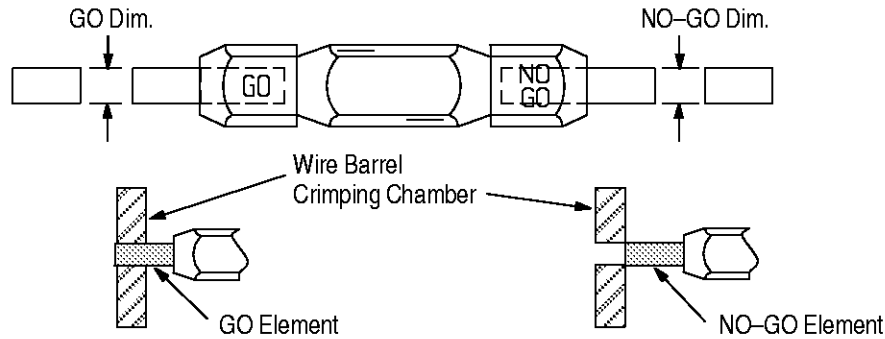

HAND TOOL	GAGE ELEMENT DIMENSIONS			
	CRIMPING CHAMBER			
	CENTER CONTACT		FERRULE	
	GO	NO-GO	GO	NO-GO
69477-4	1.066 - 1.071 [.0420 - .0422]	1.155 - 1.160 [.0455 - .0457]	4.241 - 4.246 [.1670 - .1672]	4.394 - 4.399 [.1730 - .1732]
220009-1	1.257 - 1.262 [.0495 - .0497]	1.333 - 1.338 [.0525 - .0527]	4.241 - 4.246 [.1670 - .1672]	4.394 - 4.399 [.1730 - .1732]
220009-5	1.066 - 1.071 [.0420 - .0422]	1.155 - 1.160 [.0455 - .0457]	4.241 - 4.246 [.1670 - .1672]	4.394 - 4.399 [.1730 - .1732]
220187-1	1.244 - 1.249 [.0490 - .0492]	1.333 - 1.338 [.0525 - .0527]	5.181 - 5.186 [.2040 - .2042]	5.334 - 5.339 [.2100 - .2102]
220187-2	1.066 - 1.071 [.0420 - .0422]	1.155 - 1.160 [.0455 - .0457]	6.019 - 6.024 [.2370 - .2372]	6.172 - 6.177 [.2430 - .2432]

Figure 6

D. CERTI-CRIMP Ratchet Inspection

Obtain a 0.025 [.001] shim that is suitable for checking the clearance between the bottoming surfaces of the crimping jaws.

NOTE

The bottoming surfaces are on either side of the center contact crimp. The tools are not designed to bottom at the tip of the tool. See Figure 7.

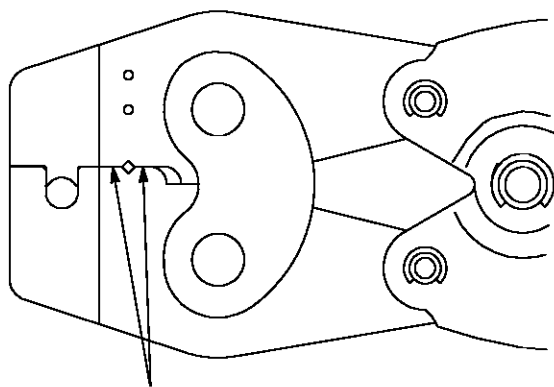

Bottoming Surfaces are on Either Side of the Center Contact Crimp

Figure 7

Then proceed as follows:

1. Select a connector and **maximum** size cable for the tool.

2. Position the contact and cable between the crimping jaws, according to Section 3, CRIMPING PROCEDURE. Holding the cable in place, squeeze the tool handles together until the CERTI-CRIMP ratchet releases. Hold the tool handles in this position, maintaining just enough pressure to keep the jaws closed.

3. Check the clearance between the bottoming surfaces of the crimping jaws. If the clearance is 0.025 [.001] or less, the ratchet is satisfactory. If clearance exceeds 0.025 [.001], the ratchet is out of adjustment and must be repaired. See Section 5, REPLACEMENT AND REPAIR.

5. REPLACEMENT AND REPAIR

Replaceable parts are listed in Figure 8. Parts other than those listed in Figure 8 should be replaced by AMP to ensure quality and reliability of the tool. Order replacement parts through your AMP representative, or call 1-800-526-5142, or send a facsimile of your purchase order to 1-717-986-7605, or write to:

CUSTOMER SERVICE (38-35)
AMP INCORPORATED
P.O. BOX 3608
HARRISBURG, PA 17105-3608

For tool repair service, please contact an AMP representative at 1-800-526-5136.

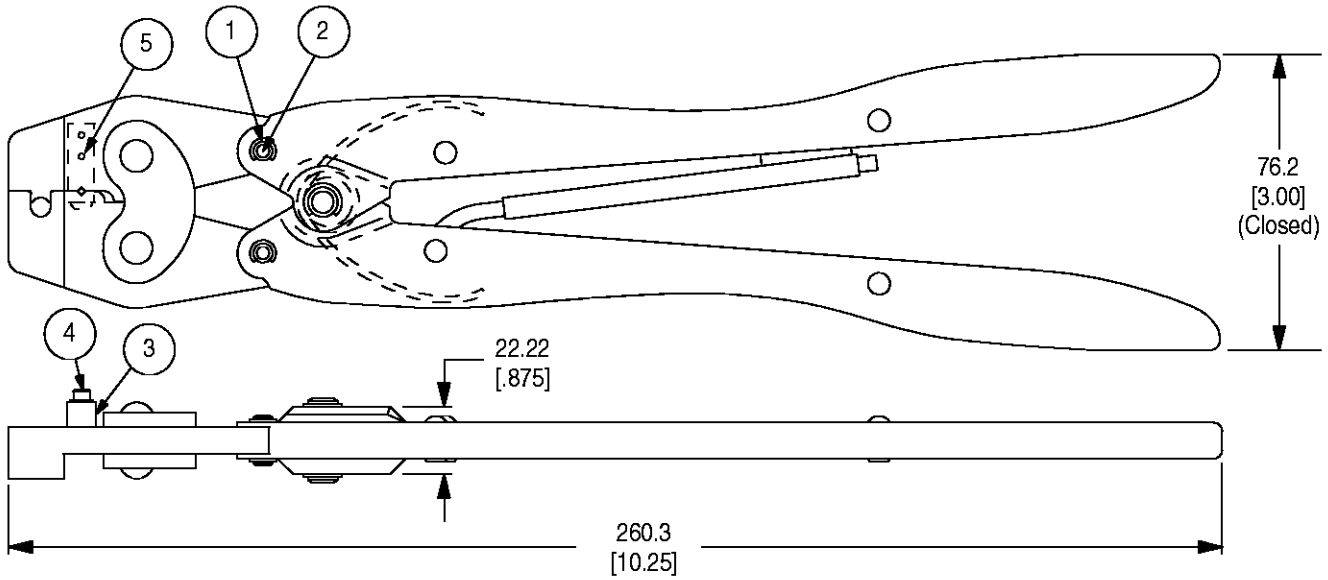

WEIGHT: 595 g [1 lb. 5 oz.]

REPLACEMENT PARTS

ITEM	HAND TOOL PART NUMBER				DESCRIPTION	QTY PER TOOL
	69477-4	220009-1	220009-5	220187-1 220187-2		
1	21045-3	21045-3	21045-3	21045-3	RING, Retaining	4
2	1-23619-6	1-23619-6	1-23619-6	1-23619-6	PIN, Retaining	2
3	310415-1	4-304052-8	843471-1	843471-1	LOCATOR	1
4	308665-1	N/A	843472-1	843472-1	STOP	1
5	1-21000-1	1-21000-0	8-21000-5	1-21000-1	SCREW	2

Figure 8

6. REVISION SUMMARY

Since the previous release of this sheet, the following changes were made:

Per EC 0990-0755-99:

- Updated document to corporate requirements
- Changed tool repair service information in Section 5, REPLACEMENT AND REPAIR