

## Multi-Standard Fully Integrated 13.56-MHz Radio Frequency Identification (RFID) Analog Front End and Data Framing Reader System

### FEATURES

- Completely Integrated Protocol Handling (OSI Model Layer 3 and Below)
- Separate Internal High-PSRR Power Supplies for Analog, Digital, and PA Sections Provides Noise Isolation for Superior Read Range and Reliability
- Dual Receiver Input With AM and PM Demodulation to Minimize Communication Holes (Patent Pending).
- Receiver AM and PM RSSI
- Reader-to-Reader Anti-Collision
- High Integration Reduces Total BOM and Board Area
  - Single External 13.56-MHz Crystal Oscillator
  - MCU-Selectable Clock-Frequency Output of RF, RF/2, or RF/4
  - Adjustable 20-mA, High-PSRR LDO for Powering External MCU
- Easy to Use With High Flexibility
  - Auto-Configured Default Modes for Each Supported ISO Protocol
  - 11 User-Programmable Registers
  - Selectable Receiver Gain and AGC
  - Programmable Output Power (100 mW or 200 mW)
  - Adjustable ASK Modulation Range (8% to 30%)
  - Built-In Receiver Band-Pass Filter With User-Selectable Corner Frequencies
- Wide Operating Voltage Range of 2.7 V to 5.5 V
- Ultralow-Power Modes
  - Power Down < 1  $\mu$ A
  - Standby 120  $\mu$ A
  - Active (Rx only) 10 mA
- Parallel 8-Bit or Serial 4-Pin SPI Interface With MCU Using 12-Byte FIFO
- Ultrasmall 32-Pin QFN Package (5 mm  $\times$  5 mm)
- Available tools
  - Reference Design/EVM With Development Software
  - Source Code Available for MSP430

### APPLICATIONS

- Secure Access Control
- Product Authentication
  - Printer Ink Cartridges
  - Blood Glucose Monitors
- Contactless Payment Systems

### DESCRIPTION

The TRF7960/61 is an integrated analog front end and data framing system for a 13.56-MHz RFID reader system. Built-in programming options make it suitable for a wide range of applications both in proximity and vicinity RFID systems.

The reader is configured by selecting the desired protocol in the control registers. Direct access to all control registers allows fine tuning of various reader parameters as needed.

Table 1. PRODUCT SELECTION TABLE

DEVICE	PROTOCOLS					
	ISO14443A/B				ISO15693 ISO18000-3	Tag-it™
	106 kbps	212 kbps	424 kbps	848 kbps		
TRF7960	X	X	X	X	X	X
TRF7961					X	X



Please be aware that an important notice concerning availability, standard warranty, and use in critical applications of Texas Instruments semiconductor products and disclaimers thereto appears at the end of this data sheet.

Tag-it is a trademark of Texas Instruments Incorporated.



These devices have limited built-in ESD protection. The leads should be shorted together or the device placed in conductive foam during storage or handling to prevent electrostatic damage to the MOS gates.

**DESCRIPTION (CONTINUED)**

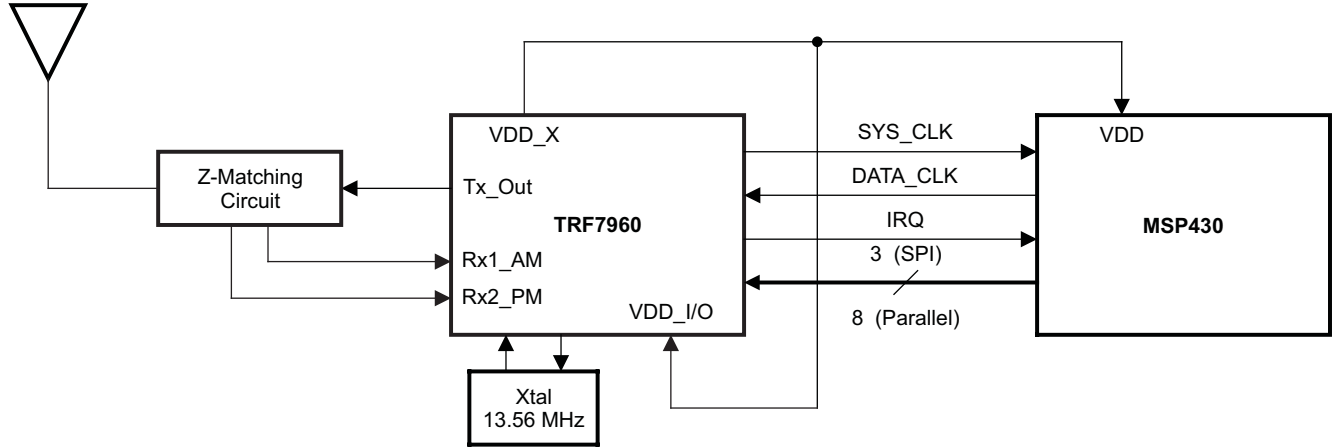

**Figure 1. Typical Application**

A parallel or serial interface can be used for communication between the MCU and reader. When hardware encoders and decoders are used (accelerators for different standards), transmission and receive functions use a 12-byte FIFO register. For direct transmit or receive functions, the encoders/decoders can be bypassed in order for the MCU to process the data in real time. The transmitter has selectable output-power levels of 100 mW (20 dBm) or 200 mW (23 dBm) into a 50-Ω load (at 5-V supply) and is capable of ASK or OOK modulation. Integrated voltage regulators ensure power-supply noise rejection for the complete reader system.

Data transmission comprises low-level encoding for ISO15693, modified Miller for ISO14443-A, high-bit-rate systems, Tag-it, and HF-EPC system coding. Included with the data encoding is automatic generation of SOF, EOF, CRC, and/or parity bits.

The receiver system enables AM and PM demodulation using a dual-input architecture. The receiver also includes an automatic gain control option and selectable gain. Also included is a selectable bandwidth to cover a broad range of input subcarrier signal options. The received signal strength for AM and PM modulation is accessible via the RSSI register. The receiver output is selectable between a digitized subcarrier signal and any of eleven integrated subcarrier decoders (two for ISO15693 low bit rate, two for ISO15693 high bit rate, two for ISO14443, three for ISO14443 high bit rates, one for Tag-it, and one for HF-EPC system). Selected decoders also deliver bit stream and a data clock as outputs.

The receiver system also includes a framing system. This system performs the CRC and/or parity check, removes the EOF and SOF settings, and organizes the data in bytes. Framed data is then accessible to the MCU via a 12-byte FIFO register and MCU interface. The framing supports ISO14443 and ISO15693 protocols.

The TRF7960/61 supports data communication levels between 1.8 V–5.5 V for the MCU I/O interface while also providing a data synchronization clock. An auxiliary 20-mA regulator (pin 32) is available for additional system circuits.

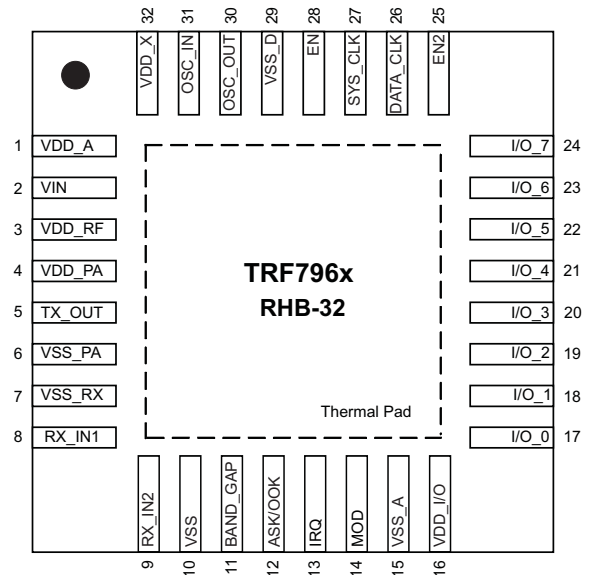

**Figure 2. TRF796x Pin Assignments (Top View)**

## ABSOLUTE MAXIMUM RATINGS

over operating free-air temperature range (unless otherwise noted)<sup>(1)</sup>

		VALUE	UNIT
V <sub>IN</sub>	Supply voltage	6	V
I <sub>O</sub>	Output current	150	mA
Continuous power dissipation		See Dissipation Rating Table	
T <sub>J</sub>	Maximum junction temperature, any condition <sup>(2)</sup>	140	°C
	Maximum junction temperature, continuous operation, long-term reliability <sup>(2)</sup>	125	°C
T <sub>stg</sub>	Storage temperature range	–55 to 150	°C
Lead temperature 1,6 mm (1/16 inch) from case for 10 seconds		300	°C
ESDS rating	HBM (human body model)	2	kV
	CDM (charged device model)	500	V
	MM (machine model)	200	

- (1) The absolute maximum ratings under any condition is limited by the constraints of the silicon process. Stresses above these ratings may cause permanent damage. Exposure to absolute maximum conditions for extended periods may degrade device reliability. These are stress ratings only and functional operation of the device at these or any other conditions beyond those specified are not implied.
- (2) The maximum junction temperature for continuous operation is limited by package constraints. Operation above this temperature may result in reduced reliability and/or lifetime of the device.

**TABLE 5. PACKAGING/ORDERING INFORMATION<sup>(1)</sup>**

PACKAGED DEVICES	PACKAGE TYPE	TRANSPORT MEDIA	QUANTITY
TRF7960RHBT	RHB-32	Tape and reel	250
TRF7960RHBR		Tape and reel	3000
TRF7961RHBT	RHB-32	Tape and reel	250
TRF7961RHBR		Tape and reel	3000

- (1) For the most current package and ordering information, see the Package Option Addendum at the end of this document, or see the TI Web site at [www.ti.com](http://www.ti.com).

## DISSIPATION RATINGS TABLE PER PACKAGE

PACKAGE	$\theta_{JC}$ (°C/W)	$\theta_{JA}$ <sup>(1)</sup> (°C/W)	POWER RATING <sup>(2)</sup>	
			T <sub>A</sub> ≤ 25°C	T <sub>A</sub> = 85°C
RHB (32)	31	36.4	2.7 W	1.1 W

- (1) This data was taken using the JEDEC standard high-K test PCB.
- (2) Power rating is determined with a junction temperature of 125°C. This is the point where distortion starts to increase substantially. Thermal management of the final PCB should strive to keep the junction temperature at or below 125°C for best performance and long-term reliability.

## RECOMMENDED OPERATING CONDITIONS

over operating free-air temperature range (unless otherwise noted)

		MIN	TYP	MAX	UNIT
V <sub>IN</sub>	Supply voltage	2.7	5	5.5	V
T <sub>J</sub>	Operating virtual junction temperature range	–40		125	°C
T <sub>A</sub>	Operating ambient temperature range	–40	25	110	°C
Load impedance at TX OUT (pin 5)			10		Ω

**PACKAGING INFORMATION**

Orderable Device	Status <sup>(1)</sup>	Package Type	Package Drawing	Pins	Package Qty	Eco Plan <sup>(2)</sup>	Lead/Ball Finish	MSL Peak Temp <sup>(3)</sup>
TRF7960RHBR	ACTIVE	QFN	RHB	32	3000	Green (RoHS & no Sb/Br)	CU NIPDAU	Level-2-260C-1 YEAR
TRF7960RHBT	ACTIVE	QFN	RHB	32	250	Green (RoHS & no Sb/Br)	CU NIPDAU	Level-2-260C-1 YEAR
TRF7961RHBR	ACTIVE	QFN	RHB	32	3000	Green (RoHS & no Sb/Br)	CU NIPDAU	Level-2-260C-1 YEAR
TRF7961RHBT	ACTIVE	QFN	RHB	32	250	Green (RoHS & no Sb/Br)	CU NIPDAU	Level-2-260C-1 YEAR

<sup>(1)</sup> The marketing status values are defined as follows:

**ACTIVE:** Product device recommended for new designs.

**LIFEBUY:** TI has announced that the device will be discontinued, and a lifetime-buy period is in effect.

**NRND:** Not recommended for new designs. Device is in production to support existing customers, but TI does not recommend using this part in a new design.

**PREVIEW:** Device has been announced but is not in production. Samples may or may not be available.

**OBSOLETE:** TI has discontinued the production of the device.

<sup>(2)</sup> Eco Plan - The planned eco-friendly classification: Pb-Free (RoHS), Pb-Free (RoHS Exempt), or Green (RoHS & no Sb/Br) - please check <http://www.ti.com/productcontent> for the latest availability information and additional product content details.

**TBD:** The Pb-Free/Green conversion plan has not been defined.

**Pb-Free (RoHS):** TI's terms "Lead-Free" or "Pb-Free" mean semiconductor products that are compatible with the current RoHS requirements for all 6 substances, including the requirement that lead not exceed 0.1% by weight in homogeneous materials. Where designed to be soldered at high temperatures, TI Pb-Free products are suitable for use in specified lead-free processes.

**Pb-Free (RoHS Exempt):** This component has a RoHS exemption for either 1) lead-based flip-chip solder bumps used between the die and package, or 2) lead-based die adhesive used between the die and leadframe. The component is otherwise considered Pb-Free (RoHS compatible) as defined above.

**Green (RoHS & no Sb/Br):** TI defines "Green" to mean Pb-Free (RoHS compatible), and free of Bromine (Br) and Antimony (Sb) based flame retardants (Br or Sb do not exceed 0.1% by weight in homogeneous material)

<sup>(3)</sup> MSL, Peak Temp. -- The Moisture Sensitivity Level rating according to the JEDEC industry standard classifications, and peak solder temperature.

**Important Information and Disclaimer:**The information provided on this page represents TI's knowledge and belief as of the date that it is provided. TI bases its knowledge and belief on information provided by third parties, and makes no representation or warranty as to the accuracy of such information. Efforts are underway to better integrate information from third parties. TI has taken and continues to take reasonable steps to provide representative and accurate information but may not have conducted destructive testing or chemical analysis on incoming materials and chemicals. TI and TI suppliers consider certain information to be proprietary, and thus CAS numbers and other limited information may not be available for release.

In no event shall TI's liability arising out of such information exceed the total purchase price of the TI part(s) at issue in this document sold by TI to Customer on an annual basis.

RHB (S-PQFP-N32)

PLASTIC QUAD FLATPACK

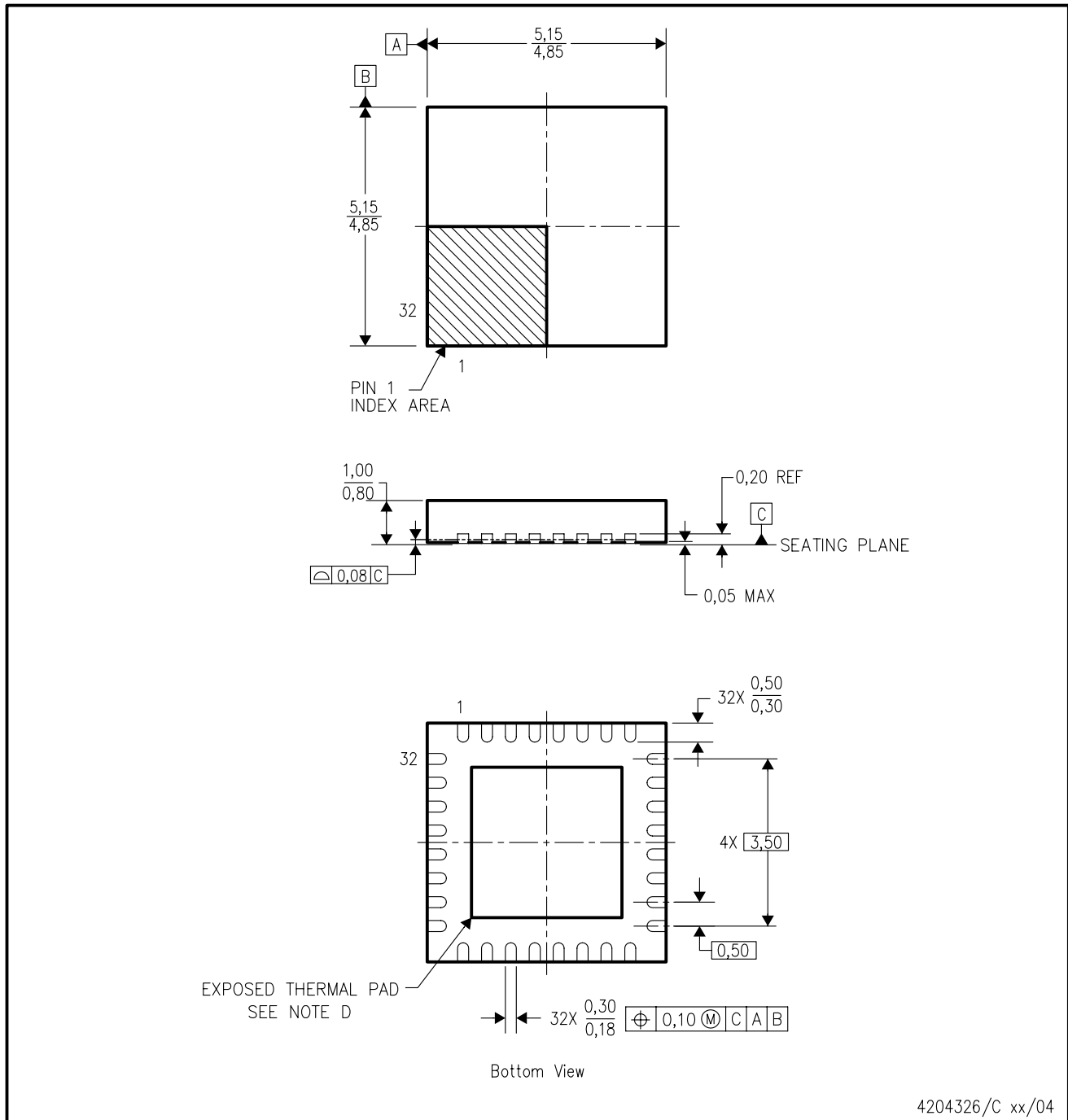

- NOTES:
- All linear dimensions are in millimeters.
  - This drawing is subject to change without notice.
  - QFN (Quad Flatpack No-Lead) Package configuration.
  - The Package thermal pad must be soldered to the board for thermal and mechanical performance. See product data sheet for details regarding the exposed thermal pad dimensions.
  - Falls within JEDEC MO-220.

THERMAL INFORMATION

This package incorporates an exposed thermal pad that is designed to be attached directly to an external heatsink. The thermal pad must be soldered directly to the printed circuit board (PCB). After soldering, the PCB can be used as a heatsink. In addition, through the use of thermal vias, the thermal pad can be attached directly to the appropriate copper plane shown in the electrical schematic for the device, or alternatively, can be attached to a special heatsink structure designed into the PCB. This design optimizes the heat transfer from the integrated circuit (IC).

For information on the Quad Flatpack No-Lead (QFN) package and its advantages, refer to Application Report, Quad Flatpack No-Lead Logic Packages, Texas Instruments Literature No. SCBA017. This document is available at [www.ti.com](http://www.ti.com).

The exposed thermal pad dimensions for this package are shown in the following illustration.

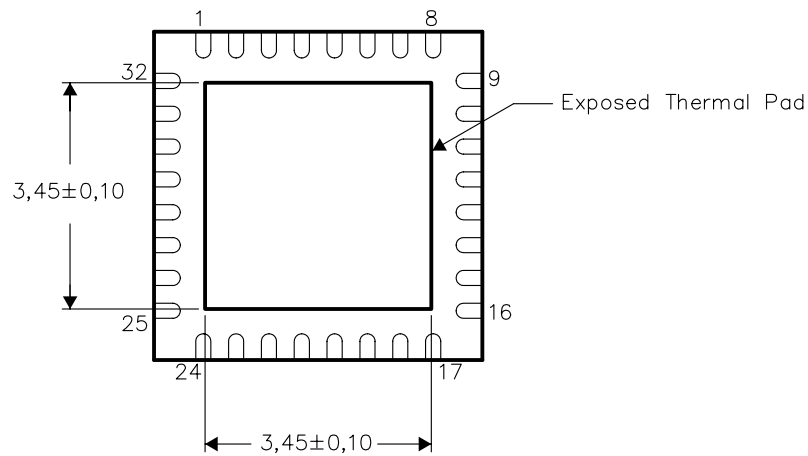

Bottom View

NOTE: All linear dimensions are in millimeters

Exposed Thermal Pad Dimensions



## IMPORTANT NOTICE

Texas Instruments Incorporated and its subsidiaries (TI) reserve the right to make corrections, modifications, enhancements, improvements, and other changes to its products and services at any time and to discontinue any product or service without notice. Customers should obtain the latest relevant information before placing orders and should verify that such information is current and complete. All products are sold subject to TI's terms and conditions of sale supplied at the time of order acknowledgment.

TI warrants performance of its hardware products to the specifications applicable at the time of sale in accordance with TI's standard warranty. Testing and other quality control techniques are used to the extent TI deems necessary to support this warranty. Except where mandated by government requirements, testing of all parameters of each product is not necessarily performed.

TI assumes no liability for applications assistance or customer product design. Customers are responsible for their products and applications using TI components. To minimize the risks associated with customer products and applications, customers should provide adequate design and operating safeguards.

TI does not warrant or represent that any license, either express or implied, is granted under any TI patent right, copyright, mask work right, or other TI intellectual property right relating to any combination, machine, or process in which TI products or services are used. Information published by TI regarding third-party products or services does not constitute a license from TI to use such products or services or a warranty or endorsement thereof. Use of such information may require a license from a third party under the patents or other intellectual property of the third party, or a license from TI under the patents or other intellectual property of TI.

Reproduction of TI information in TI data books or data sheets is permissible only if reproduction is without alteration and is accompanied by all associated warranties, conditions, limitations, and notices. Reproduction of this information with alteration is an unfair and deceptive business practice. TI is not responsible or liable for such altered documentation. Information of third parties may be subject to additional restrictions.

Resale of TI products or services with statements different from or beyond the parameters stated by TI for that product or service voids all express and any implied warranties for the associated TI product or service and is an unfair and deceptive business practice. TI is not responsible or liable for any such statements.

TI products are not authorized for use in safety-critical applications (such as life support) where a failure of the TI product would reasonably be expected to cause severe personal injury or death, unless officers of the parties have executed an agreement specifically governing such use. Buyers represent that they have all necessary expertise in the safety and regulatory ramifications of their applications, and acknowledge and agree that they are solely responsible for all legal, regulatory and safety-related requirements concerning their products and any use of TI products in such safety-critical applications, notwithstanding any applications-related information or support that may be provided by TI. Further, Buyers must fully indemnify TI and its representatives against any damages arising out of the use of TI products in such safety-critical applications.

TI products are neither designed nor intended for use in military/aerospace applications or environments unless the TI products are specifically designated by TI as military-grade or "enhanced plastic." Only products designated by TI as military-grade meet military specifications. Buyers acknowledge and agree that any such use of TI products which TI has not designated as military-grade is solely at the Buyer's risk, and that they are solely responsible for compliance with all legal and regulatory requirements in connection with such use.

TI products are neither designed nor intended for use in automotive applications or environments unless the specific TI products are designated by TI as compliant with ISO/TS 16949 requirements. Buyers acknowledge and agree that, if they use any non-designated products in automotive applications, TI will not be responsible for any failure to meet such requirements.

Following are URLs where you can obtain information on other Texas Instruments products and application solutions:

<b>Products</b>		<b>Applications</b>	
Amplifiers	<a href="http://amplifier.ti.com">amplifier.ti.com</a>	Audio	<a href="http://www.ti.com/audio">www.ti.com/audio</a>
Data Converters	<a href="http://dataconverter.ti.com">dataconverter.ti.com</a>	Automotive	<a href="http://www.ti.com/automotive">www.ti.com/automotive</a>
DSP	<a href="http://dsp.ti.com">dsp.ti.com</a>	Broadband	<a href="http://www.ti.com/broadband">www.ti.com/broadband</a>
Interface	<a href="http://interface.ti.com">interface.ti.com</a>	Digital Control	<a href="http://www.ti.com/digitalcontrol">www.ti.com/digitalcontrol</a>
Logic	<a href="http://logic.ti.com">logic.ti.com</a>	Military	<a href="http://www.ti.com/military">www.ti.com/military</a>
Power Mgmt	<a href="http://power.ti.com">power.ti.com</a>	Optical Networking	<a href="http://www.ti.com/opticalnetwork">www.ti.com/opticalnetwork</a>
Microcontrollers	<a href="http://microcontroller.ti.com">microcontroller.ti.com</a>	Security	<a href="http://www.ti.com/security">www.ti.com/security</a>
RFID	<a href="http://www.ti-rfid.com">www.ti-rfid.com</a>	Telephony	<a href="http://www.ti.com/telephony">www.ti.com/telephony</a>
Low Power Wireless	<a href="http://www.ti.com/lpw">www.ti.com/lpw</a>	Video & Imaging	<a href="http://www.ti.com/video">www.ti.com/video</a>
		Wireless	<a href="http://www.ti.com/wireless">www.ti.com/wireless</a>

Mailing Address: Texas Instruments, Post Office Box 655303, Dallas, Texas 75265  
Copyright © 2007, Texas Instruments Incorporated