

# SERPAC 021-1 (exploded isometric)

Electronic Enclosures

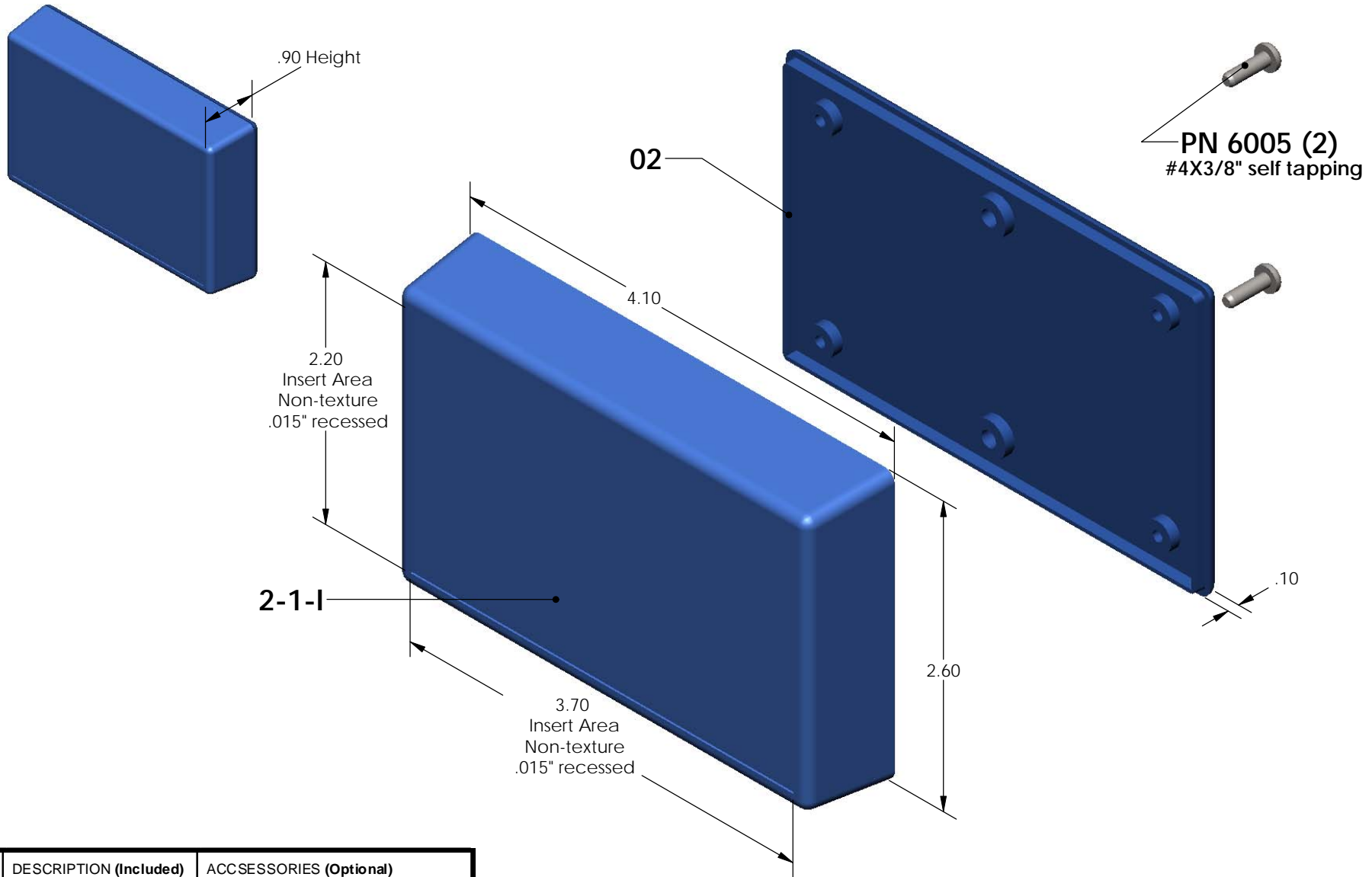

PART NO.	DESCRIPTION (Included)	ACCESSORIES (Optional)	
2-1-1	TOP	PART NO.	DESCRIPTION
02	BOTTOM	52	Non-skid feet
6005	#4X3/8" Self tapping (2)	319	Prototype grid board (Top)
		419	Prototype clad board (Top)

Notes: (Enclosure weight 0.12 lb / 55 gm)  
 1) Enclosure meets or exceeds IP40 and NEMA 1  
 2) Circuit Board drawings can be download at:  
[http://www.serpac.com/Products/Accessories/CircuitBoard/drawings/CB\\_021.pdf](http://www.serpac.com/Products/Accessories/CircuitBoard/drawings/CB_021.pdf)  
 3) All components are RoHS Compliant.

**ALL DIMENSIONS ARE ± .010" 6/26/09 (1 of 2)**  
**619 Commercial Ave. Covina, CA 91723**  
 Ph. (626) 331-0517 Fx. (626) 331-8584 [serpac.com](http://serpac.com)

# SERPAC 021-1 (user print)

Electronic Enclosures

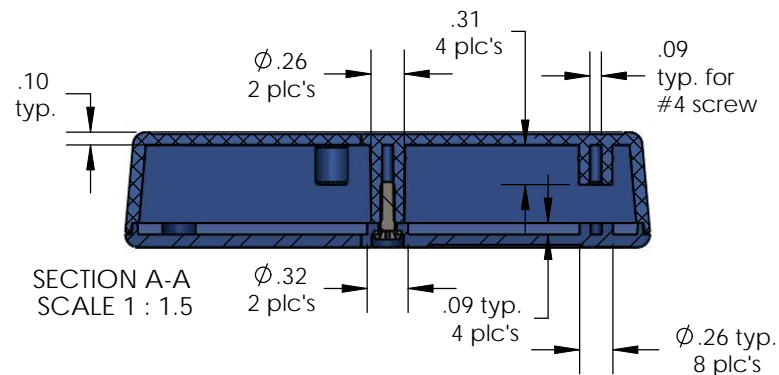
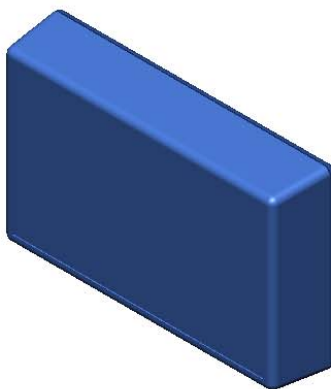
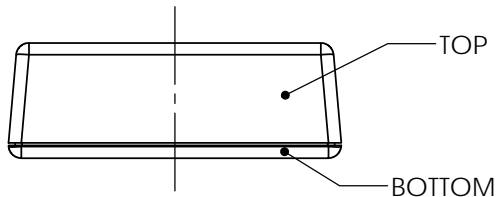
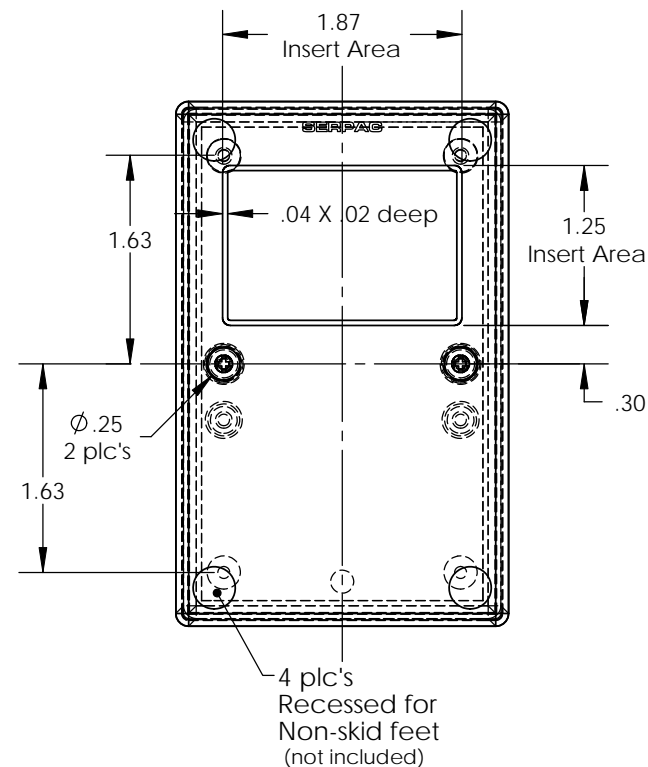
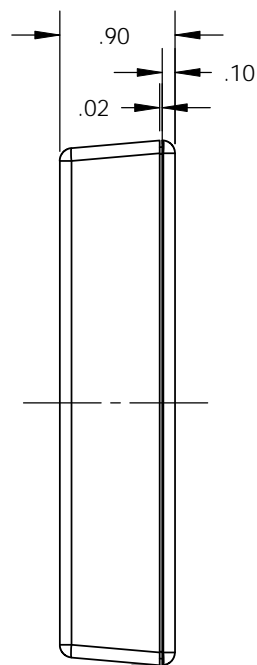
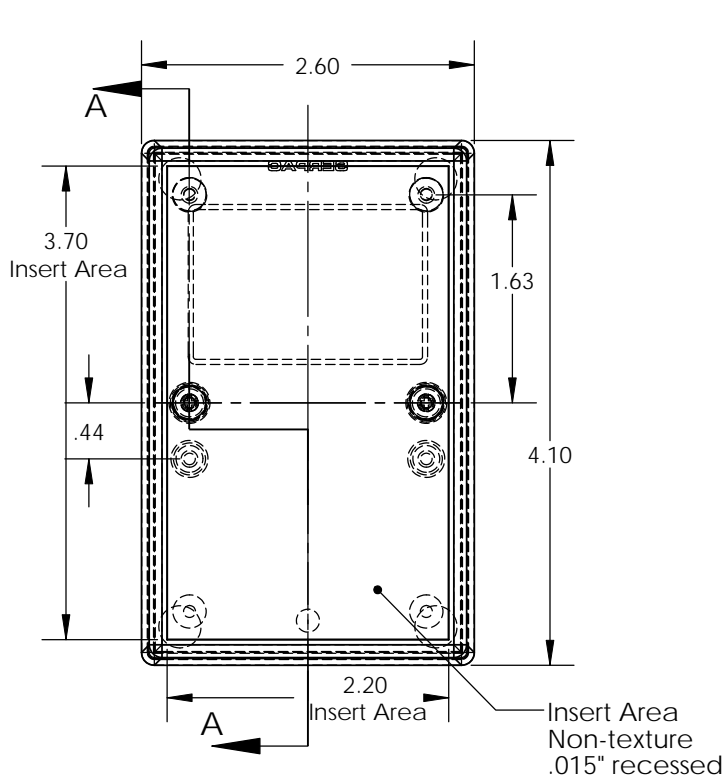

PART NO.	DESCRIPTION (Included)	ACCESSORIES (Optional)	
2-1-1	TOP	PART NO.	DESCRIPTION
02	BOTTOM	52	Non-skid feet
6005	#4X3/8" self tapping (2)	319	Prototype grid board (Top)
		419	Prototype clad board (Top)

Notes: (Enclosure weight 0.12 lb / 55 gm)  
 1) Enclosure meets or exceeds IP40 and NEMA 1  
 2) Circuit Board drawings can be download at:  
[http://www.serpac.com/Products/Accessories/CircuitBoard/drawings/CB\\_021.pdf](http://www.serpac.com/Products/Accessories/CircuitBoard/drawings/CB_021.pdf)  
 3) All components are RoHS Compliant.

ALL DIMENSIONS ARE  $\pm .010"$  6/26/09 (2 of 2)  
 619 Commercial Ave. Covina, CA 91723  
 Ph. (626) 331-0517 Fx. (626) 331-8584 www.serpac.com