

SACB-4/ 8-L-SC

Order No.: 1680568



<http://eshop.phoenixcontact.de/phoenix/treeViewClick.do?UID=1680568>

Sensor/actuator box, with LED, with spring-cage terminal blocks and double-occupied slots

Commercial data	
EAN	4017918169756
Pack	1 Pcs.
Customs tariff	85366990
Weight/Piece	0.1085 KG
Catalog page information	Page 110 (PC-2007)

Product notes

WEEE/RoHS-compliant since:
01/24/2007



<http://www.download.phoenixcontact.com>
Please note that the data given here has been taken from the online catalog. For comprehensive information and data, please refer to the user documentation. The General Terms and Conditions of Use apply to Internet downloads.

Technical data

General data	
Nominal voltage U_N	24 V DC
Max. operating voltage U_{max}	30 V DC
Max. current carrying capacity per path	2 A
Current carrying capacity per slot	4 A

SACB total current	12 A
Operating current of the indicator elements	≤ 5 mA
Number of positions	5
Number of slots	4
Degree of protection	IP65/IP67
Ambient temperature (operation)	-25 °C ... 75 °C
Sensor/actuator connection system	M12 female connector

Local diagnostics function

Local diagnostics	Supply voltage per module LED green
	Status display I/O Yellow LED

Master cable data

Type of connection	Spring-cage conn.
Stripping length	10 mm
Min. cable diameter	6.5 mm
Max. cable diameter	9.5 mm

Insulation material

Inflammability class acc. to UL 94	V0
------------------------------------	----

Certificates / Approvals

Approval logo



CUL

Nominal voltage U_N	24 V
AWG/kcmil	22-16

UL

Nominal voltage U_N	24 V
AWG/kcmil	22-16
Certification	CUL, GOST, UL

Accessories

Item	Designation	Description
Grommet		
1680377	SACB-D PG 13,5 (4,0-6,5) YE	Rubber seal for Pg screw connection 13.5, for conductor cross section 4.0...6.5 mm
1680380	SACB-D PG 13,5 (6,5-9,5) BK	Rubber seal for Pg screw connection 13.5, for conductor cross section 6.5...9.5 mm
1680393	SACB-D PG 13,5 (9,0-13,0) RD	Rubber seal for Pg screw connection 13.5, for conductor cross section 9.0...12.0 mm
Marking		
2809128	ZBN 18:UNBEDRUCKT	Unprinted marker labels, strips with 5 labels for individual labeling with M-PEN or CMS system, for terminal block width: 17.5 mm, color: White
Sealing cap		
1680539	PROT-M12	An M12 screw plug for the unoccupied M12 sockets of the sensor/ actuator cable, boxes and flush-type connectors
Tools		
1208432	SAC BIT M12-D15	Nut to mount SAC M12 cables and M12 QUICKCON connectors, for 4 mm hexagonal screwdriver
1208445	SACC BIT M12-D20	Nut for assembling SACC M12 plug-in connectors, for 4 mm hexagonal screwdriver
1206463	SZK PZ2	Screwdriver, suitable for Phillips screws Pozidriv/Supadriv, size: 2
1208429	TSD 04 SAC	Torque screwdriver, with preset torque of 0.4 Nm and 4 mm hexagonal drive

Drawings

Dimensioned drawing

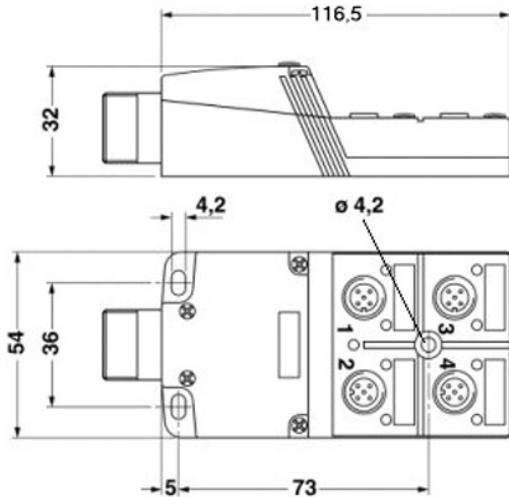

Circuit diagram

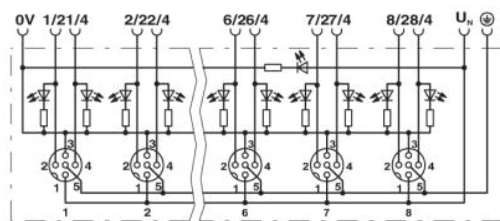

Schematic diagram

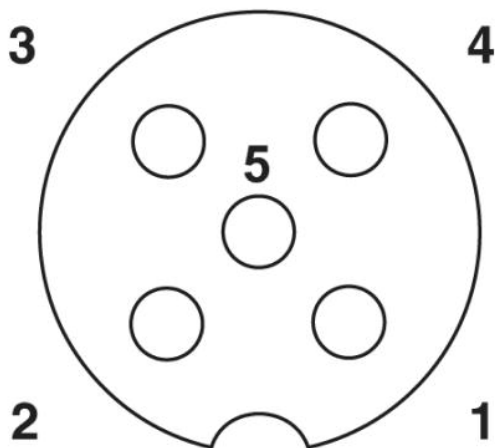

M12 slot, socket, 5-pos.

Address

PHOENIX CONTACT GmbH & Co. KG
Flachsmarktstr. 8
32825 Blomberg, Germany
Phone +49 5235 3 00
Fax +49 5235 3 41200
<http://www.phoenixcontact.de>



© 2008 Phoenix Contact
Technical modifications reserved;