



The CCM04 without card guidance is used where space is at a premium and the card guidance can be built around the connector (rather than provided by the connector itself).

The CCM04 low profile without card guidance is dedicated to applications where the overall height of the connector is paramount. A range of low profile CCM04 connectors are available with 1.25 mm thick moldings.

The wide choice of contact configurations and molding heights suit a broad range of applications.

Features

- Available in two molding heights 1,25 mm and 2,75 mm.
- The integrated card detection switch (optional) is sealed against dust and grit.
- By using an inlay finish in the contact area, the life of the precious metal is extended by more than 10 times that of standard gold plating.
- The height of the contact above the insulator is 0,75 mm, allowing a wider tolerance for the card entry slot.
- The contact area is spooned to reduce the risk of accidental (or deliberate) damage and to optimize the electrical connection with the card.
- The tip of the contact is protected by the molding so that it cannot catch on the card as the card is being inserted.
- The contact design ensures a consistent and reliable contact force over the life of the connector.
- Robustly formed printed circuit tails are well protected by the insulator body.
- The moldings are made from high temperature thermoplastic suited for infrared and convection soldering processes.
- With tape and reel packaging as standard, the connectors are designed to be automatically picked & placed.

Construction	
Contacts	Copper alloy
Plating	Contact area : Gold alloy inlay Terminals : Tin lead (2µ min)
Moldings	High temp. thermoplastic UL 94V-0 rated

Mechanical Data	
Number of Contacts	6, 8
Mechanical life	50,000 cycles min
Contact force	0.25 N min / 0.5 N max
Card detection switch actuation force	0.8 N max for actuation (end travel switch actuates when card is 0,9 mm from card stop) 1.8 N max for complete depression
Vibration 50m/s ²	Frequency 10 to 500 Hz. Acceleration Duration 6 hours - amplitude 0,35 mm Max electrical discontinuity 1µs
Shock	Peak value 500 m/s ² – Duration 11 ms 3 shocks in each direction of each axis Max electrical discontinuity 1 µs

Contact Electrical Data	
Insulation resistance	1,000 MΩ min
Resistance	100 mΩ max
Current rating	10 µA min / 1 A max
Dielectric strength	750 Vrms min

Switch Electrical Data	
Card detection switch	Normally open (closes on card insertion)
Contact resistance	100mΩ max
Dielectric strength	250 Vrms min
Current rating	1 mA min/ 10 mA max
Maximum power	0.2 VA

Environmental Data	
Operating temperature	-40°C to +85°C
Soldering temperature	Temperature/time profile acc. to CECC00802 para. 6.1, Fig. 3 with peak temperature 250°C
Damp heat	IEC 512 test number 11c (10 days)
Salt mist	IEC 512 test number 11f (96 hours)
Card detection switch	Sealed IP 54 For CCM04 1889 Sealed against dust for other versions

Ordering Code			
Part Number	Number of Contacts	Card Presence Switch	Quantity per Reel
CCM04-1801	6	No	1800
CCM04-1814	8	No	1300
CCM04-1889	8	Yes	1000
CCM04-1316	8	Yes	700
CCM04-1317	8	Yes	700

Packaging
5 reels per box.

CCM04 MK II

Dimensional Drawings

CCM04-1814 2 x 4 contacts

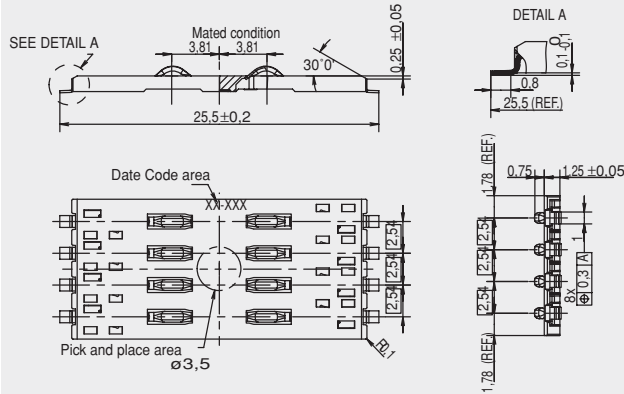

CCM04-1814 PCB layout

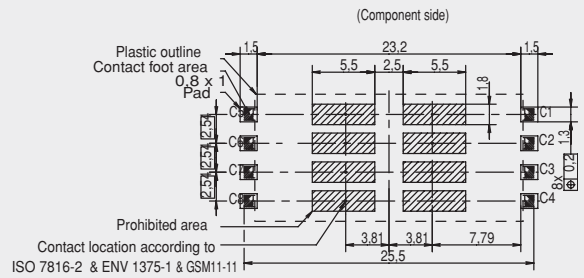

CCM04-1889 2 x 4 contacts + switch

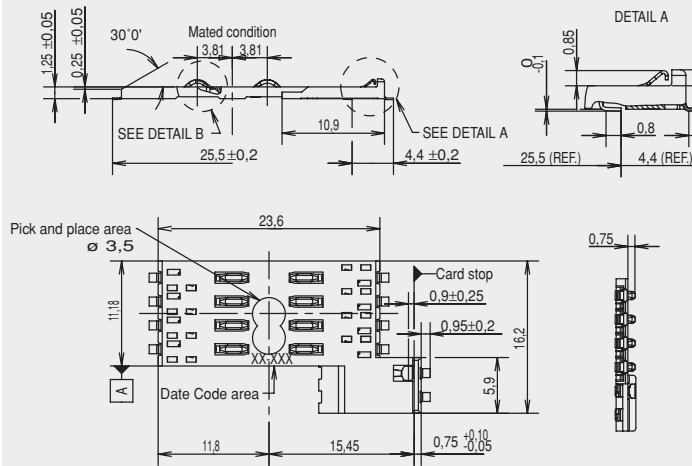

CCM04-1889 PCB Layout

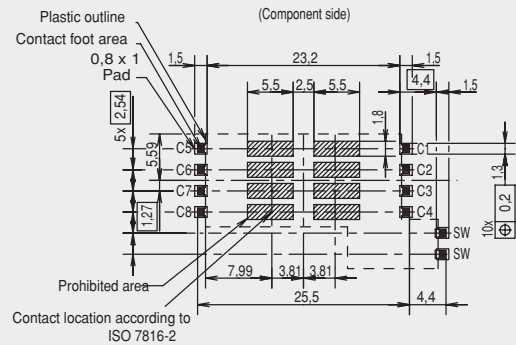

Unless otherwise stated, tolerances are ± 0,10 mm

Dimensional Drawings

CCM04-1316 2 x 4 contacts

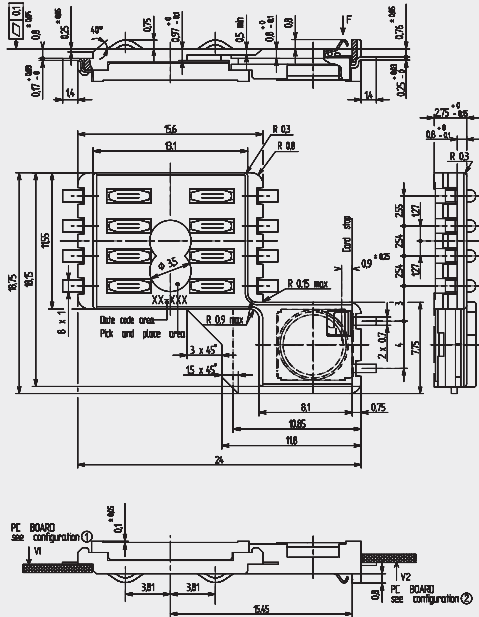

CCM04-1316 PCB layout

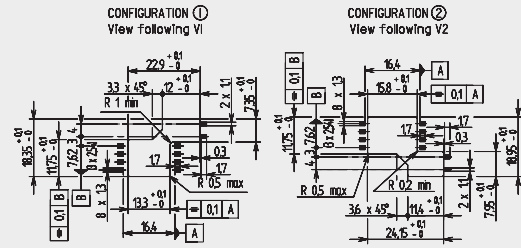

CCM04-1317 2 x 4 contacts + switch

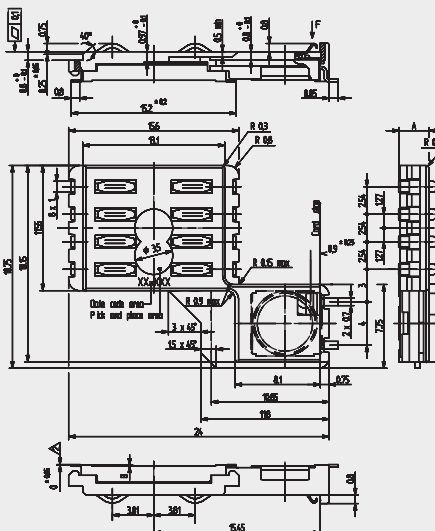

CCM04-1317 PCB Layout

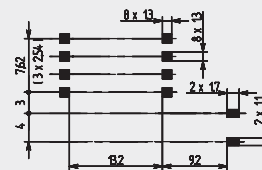

VARIANT	DESIGNATION	A ¹	B ¹
	CCM04-1317	2,75	0,1
	CCM04-1318	3,5	0,1
	CCM04-1319	4,25	0,3
	CCM04-1320	5	0,3

Unless otherwise stated, tolerances are $\pm 0,10$ mm