

Features

November 2004

- Meets requirements of GR-253 for SONET Stratum 3 and SONET Minimum Clocks (SMC)
- Meets requirements of GR-1244 for Stratum 3
- Meets requirements of G.813 Option 1 and 2 for SDH Equipment Clocks (SEC)
- Generates clocks for ST-BUS, DS1, DS2, DS3, OC-3, E1, E3, STM-1 and 19.44 MHz
- Holdover accuracy of 4×10^{-12} meets GR-1244 Stratum 3E and ITU-T G.812 requirements
- Continuously monitors both references for frequency accuracy exceeding ± 12 ppm
- Provides "hit-less" reference switching
- Compensates for Master Clock Oscillator accuracy
- Automatically detects frequency of both reference clocks and synchronizes to any combination of 8 kHz, 1.544 MHz, 2.048 MHz and 19.44 MHz reference frequencies
- Allows Hardware or Microprocessor control
- Pin compatible with ZL30410, ZL30402 and MT90401

Ordering Information

 ZL30407QCC 80 Pin LQFP Trays
 ZL30407QCC1 80 Pin LQFP* Trays

*Pb Free Matte Tin

-40°C to +85°C
Applications

- Synchronization for SDH and SONET Network Elements
- Clock generation for ST-BUS and GCI backplanes

Description

The ZL30407 is a Network Element Phase-Locked Loop designed to synchronize SDH and SONET systems. In addition, it generates multiple clocks for legacy PDH equipment and provides timing for ST-BUS and GCI backplanes.

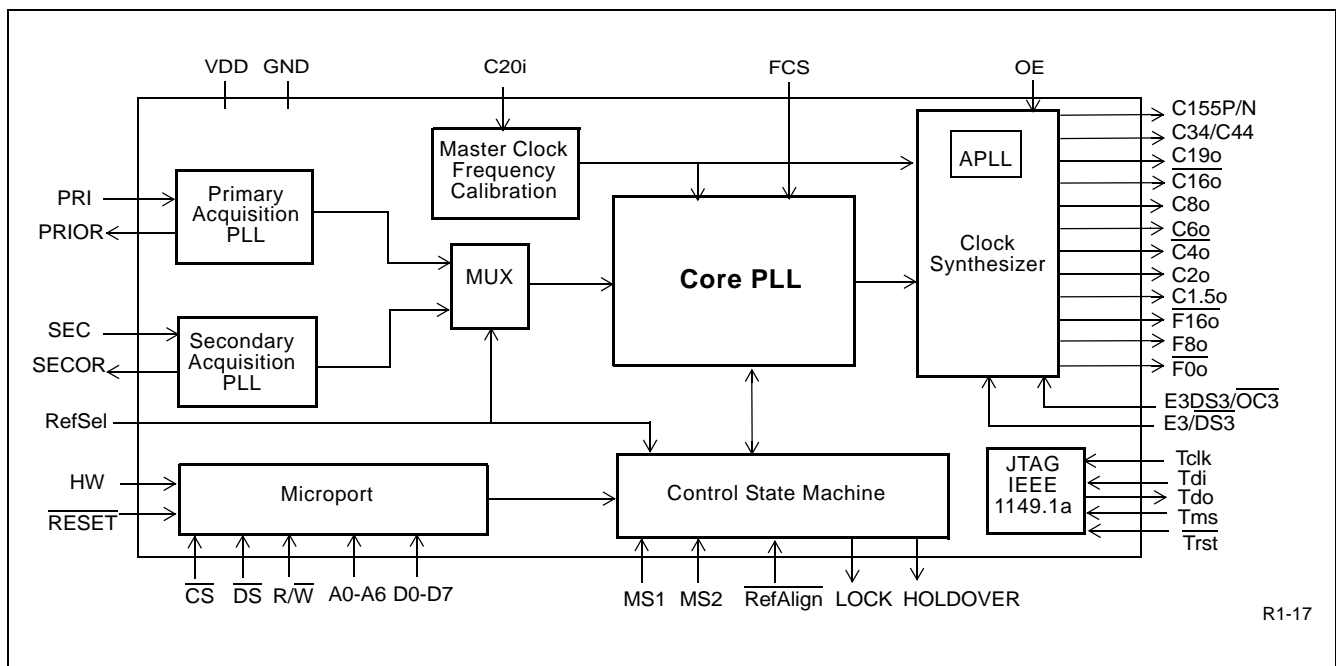
Figure 1 - Functional Block Diagram

The ZL30407 operates in NORMAL (LOCKED), HOLDOVER and FREE-RUN modes to ensure that in the presence of jitter, wander and interruptions to the reference signals, the generated clocks meet international standards. The filtering characteristics of the PLL are hardware or software selectable and they do not require any external adjustable components. The ZL30407 uses an external 20 MHz Master Clock Oscillator to provide a stable timing source for the HOLDOVER operation.

The ZL30407 operates from a single 3.3 V power supply and offers a 5 V tolerant microprocessor interface.

Table of Contents

1.0 ZL30407 Pinout	6
1.1 Pin Connections	6
2.0 Functional Description	12
2.1 Acquisition PLLs	12
2.2 Core PLL	12
2.2.1 Digitally Controlled Oscillator (DCO)	13
2.2.2 Filters	13
2.2.3 Phase Slope Limiters	14
2.2.4 Lock Indicator (LOCK)	14
2.2.5 Reference Alignment (RefAlign)	14
2.2.5.1 Using RefAlign with 1.544 MHz, 2.048 MHz or 19.44 MHz Reference	14
2.2.5.2 Using RefAlign with an 8 kHz Reference	15
2.3 Clock Synthesizer	16
2.3.1 Output Clocks	16
2.3.2 Output Clocks Phase Adjustment	17
2.4 Control State Machine	17
2.4.1 Clock Modes	17
2.4.2 ZL30407 State Machine	17
2.4.2.1 Reset State	18
2.4.2.2 Free-Run State (Free-Run mode)	18
2.4.2.3 Normal State (Normal Mode or Locked Mode)	18
2.4.2.4 Holdover State (Holdover Mode)	19
2.4.2.5 Auto Holdover State	19
2.4.3 State Transitions	20
2.5 Master Clock Frequency Calibration Circuit	20
2.6 Microprocessor Interface	21
2.7 JTAG Interface	21
3.0 Hardware and Software Control	21
3.1 Hardware Control	22
3.1.1 Control Pins	22
3.1.2 Status Pins	23
3.2 Software Control	23
3.2.1 Control Bits	23
3.2.2 ZL30407 Register Map	24
4.0 Applications	33
4.1 ZL30407 Mode Switching - Examples	33
4.1.1 System Start-up Sequence: FREE-RUN --> HOLDOVER --> NORMAL	34
4.1.2 Single Reference Operation: NORMAL --> AUTO HOLDOVER --> NORMAL	35
4.1.3 Single 8 kHz Reference Operation: NORMAL --> AUTO HOLDOVER--> HOLDOVER --> NORMAL	36
4.1.4 Dual Reference Operation: NORMAL --> AUTO HOLDOVER--> HOLDOVER --> NORMAL	37
4.2 Master/Slave Timing Protection Switching	39
4.3 Programming Master Clock Oscillator Frequency Calibration Register	40
4.4 Power supply filtering	40
5.0 Characteristics	41
5.1 AC and DC Electrical Characteristics	41
5.2 Performance Characteristics	49

List of Figures

Figure 1 - Functional Block Diagram	1
Figure 2 - Pin Connections for 80-pin LQFP package	6
Figure 3 - Core PLL Functional Block Diagram	13
Figure 4 - C34/C44, C155o Clock Generation Options	17
Figure 5 - ZL30407 State Machine in Software Control configuration	18
Figure 6 - ZL30407 State Machine in Hardware Control configuration	19
Figure 7 - Hardware and Software Control Options	22
Figure 8 - Primary and Secondary Reference Out of Range Thresholds	27
Figure 9 - Transition From Free-run to Normal Mode	34
Figure 10 - Automatic Entry into Auto Holdover State and Recovery into Normal Mode	35
Figure 11 - Recovery Procedure From a Single 8 kHz Reference Failure by Transitioning Through the Holdover State	36
Figure 12 - Entry into Auto Holdover State and Recovery into Normal Mode by Switching References	37
Figure 13 - Manual Reference Switching	38
Figure 14 - Block Diagram of the Master/Slave Timing Protection Switching	39
Figure 15 - Power Supply Filtering	40
Figure 16 - Timing Parameters Measurement Voltage Levels	42
Figure 17 - Microport Timing	43
Figure 18 - ST-BUS and GCI Output Timing	44
Figure 19 - DS1 and DS2 Clock Timing	45
Figure 20 - C155o and C19o Timing	46
Figure 21 - Input Reference to Output Clock Phase Offset	47
Figure 22 - Input Control Signal Setup and Hold Time	48
Figure 23 - E3 and DS3 Output Timing	48

List of Tables

Table 1 - Loop Filter Selection	13
Table 2 - Operating Modes and States	22
Table 3 - Filter Characteristic Selection	23
Table 4 - Reference Source Select	23
Table 5 - ZL30407 Register Map	24
Table 6 - Control Register 1 (R/W)	25
Table 7 - Status Register 1 (R)	26
Table 8 - Control Register 2 (R/W)	27
Table 9 - Phase Offset Register 2 (R/W)	28
Table 10 - Phase Offset Register 1 (R/W)	28
Table 11 - Device ID Register (R)	28
Table 12 - Control Register 3 (R/W)	29
Table 13 - Clock Disable Register 1 (R/W)	29
Table 14 - Clock Disable Register 2 (R/W)	30
Table 15 - Core PLL Control Register (R/W)	30
Table 16 - Fine Phase Offset Register (R/W)	31
Table 17 - Primary Acquisition PLL Status Register (R)	31
Table 18 - Secondary Acquisition PLL Status Register (R)	32
Table 19 - Master Clock Frequency Calibration Register 4 (R/W)	32
Table 20 - Master Clock Frequency Calibration Register 3 (R/W)	32
Table 21 - Master Clock Frequency Calibration Register 2 (R/W)	32
Table 22 - Master Clock Frequency Calibration Register 1 (R/W)	33

1.0 ZL30407 Pinout

1.1 Pin Connections

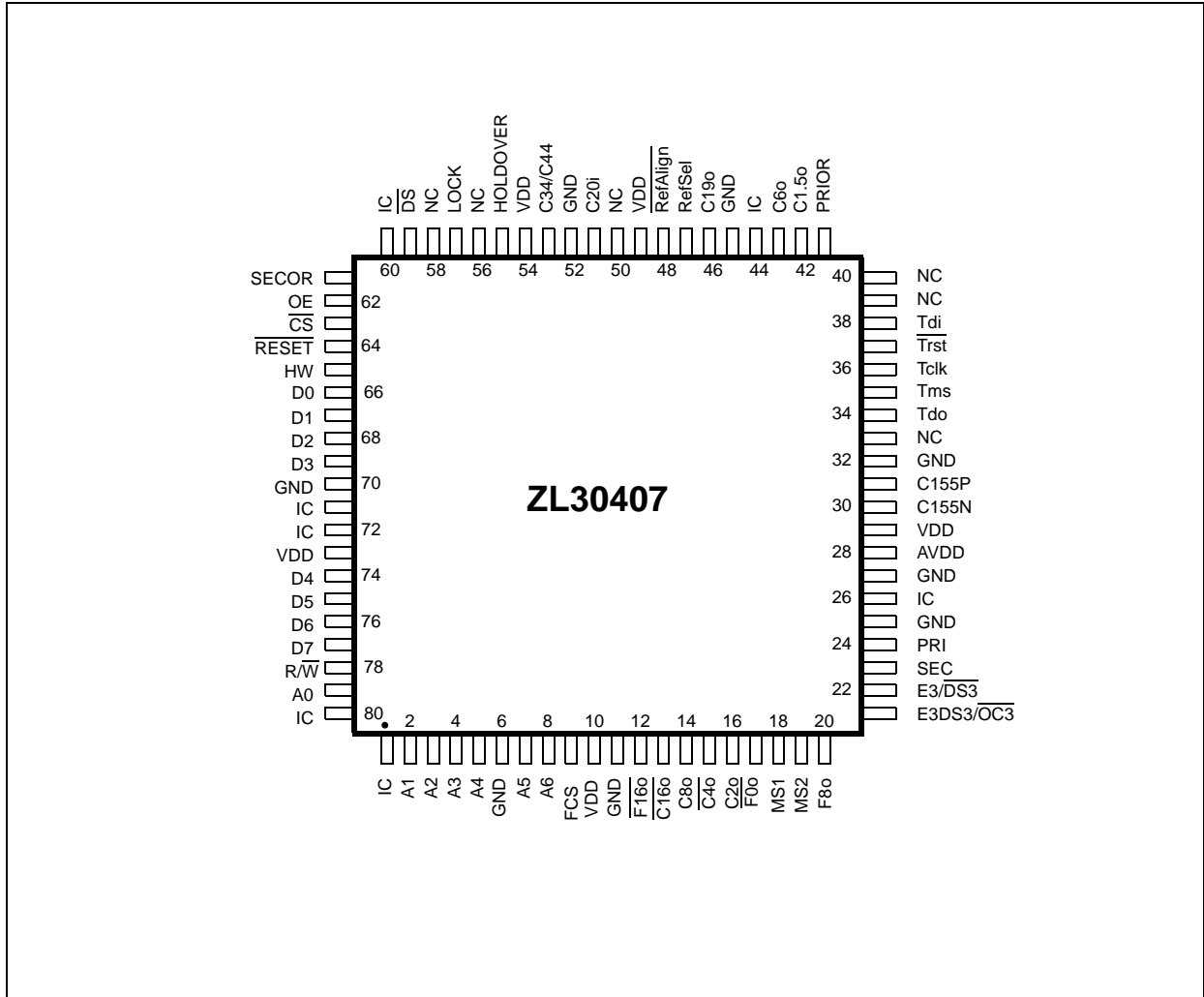

Figure 2 - Pin Connections for 80-pin LQFP package

Pin Description

Pin #	Name	Description
1	IC	Internal Connection. Leave unconnected.
2-5	A1-A4	Address 1 to 4 (5 V tolerant input). Address inputs for the parallel processor interface. Connect to ground in Hardware Control.
6	GND	Ground. Negative power supply.
7-8	A5-A6	Address 5 to 6 (5 V tolerant input). Address inputs for the parallel processor interface. Connect to ground in Hardware Control.
9	FCS	Filter Characteristic Select (Input). In Hardware Control, FCS selects the filtering characteristics of the ZL30407. Set this pin high to have a loop filter corner frequency of 0.1 Hz and limit the phase slope to 885 ns/sec. Set this pin low to have corner frequency of 1.5 Hz and limit the phase slope to 41 ns per 1.326 ms. Connect to ground in Software Control. This pin is internally pulled down to GND.
10	VDD	Positive Power Supply
11	GND	Ground
12	$\overline{F16o}$	Frame Pulse ST-BUS 8.192 Mbps (CMOS tristate output). This is an 8 kHz, 61 ns wide, active low framing pulse, which marks beginning of a ST-BUS frame. This frame pulse is typically used for ST-BUS operation at 8.192 Mbps.
13	$\overline{C16o}$	Clock 16.384 MHz (CMOS tristate output). This clock is used for ST-BUS operation at 8.192 Mbps.
14	C8o	Clock 8.192 MHz (CMOS tristate output). This clock is used for ST-BUS operation at 8.192 Mbps.
15	$\overline{C4o}$	Clock 4.096 MHz (CMOS tristate output). This clock is used for ST-BUS operation at 2.048 Mbps.
16	C2o	Clock 2.048 MHz (CMOS tristate output). This clock is used for ST-BUS operation at 2.048 Mbps.
17	$\overline{F0o}$	Frame Pulse ST-BUS 2.048 Mbps (CMOS tristate output). This is an 8 kHz, 244ns, active low framing pulse, which marks the beginning of a ST-BUS frame. This is typically used for ST-BUS operation at 2.048 Mbps and 4.096 Mbps.
18	MS1	Mode Select 1 (Input). The MS1 and MS2 pins select the ZL30407 mode of operation (Normal, Holdover or Free-run), see Table 2 on page 22 for details. The logic level at this input is sampled by the rising edge of the F8o frame pulse. Connect to ground in Software Control.
19	MS2	Mode Select 2 (Input). The MS2 and MS1 pins select the ZL30407 mode of operation (Normal, Holdover or Free-run), see Table 2 on page 22 for details. The logic level at this input is sampled by the rising edge of the F8o frame pulse. Connect to ground in Software Control.

Pin Description (continued)

Pin #	Name	Description
20	F8o	Frame Pulse ST-BUS/GCI 8.192 Mbps (CMOS tristate output). This is an 8 kHz, 122 ns, active high framing pulse, which marks the beginning of a ST-BUS/GCI frame. This is typically used for ST-BUS/GCI operation at 8.192 Mbps. See Figure 18 for details.
21	E3DS3/ $\overline{\text{OC3}}$	E3DS3 or OC3 Selection (Input). In Hardware Control, a logic low on this pin enables the C155P/N outputs (pin 30 and pin 31) and sets the C34/C44 output (pin 53) to provide C8 or C11 clocks. Logic high at this input disables the C155 clock outputs (high impedance) and sets C34/C44 output to provide C34 and C44 clocks. In Software Control connect this pin to ground.
22	E3/ $\overline{\text{DS3}}$	E3 or DS3 Selection (Input). In Hardware Control, when the E3DS3/ $\overline{\text{OC3}}$ pin is set high, logic low on E3/ $\overline{\text{DS3}}$ pin selects a 44.736 MHz clock on C34/C44 output and logic high selects 34.368 MHz clock. When E3DS3/ $\overline{\text{OC3}}$ pin is set low, logic low on E3/ $\overline{\text{DS3}}$ pin selects 11.184 MHz clock on C34/C44 output and logic high selects 8.592 MHz clock. Connect this input to ground in Software Control.
23	SEC	Secondary Reference (Input). This input is used as a secondary reference source for synchronization. The ZL30407 can synchronize to the falling edge of the 8 kHz, 1.544 MHz or 2.048 MHz clocks and the rising edge of the 19.44 MHz clock. In Hardware Control, selection of the input reference is based upon the RefSel control input. This pin is internally pulled up to VDD.
24	PRI	Primary Reference (Input). This input is used as a primary reference source for synchronization. The ZL30407 can synchronize to the falling edge of the 8 kHz, 1.544 MHz or 2.048 MHz clocks and the rising edge of the 19.44 MHz clock. In Hardware Control, selection of the input reference is based upon the RefSel control input. This pin is internally pulled up to VDD.
25	GND	Ground
26	IC	Internal Connection. Leave unconnected.
27	GND	Ground
28	AVDD	Positive Analog Power Supply. Connect this pin to VDD.
29	VDD	Positive Power Supply
30 31	C155N C155P	Clock 155.52 MHz (LVDS output). Differential outputs for the 155.52 MHz clock. These outputs are enabled by applying logic low to E3DS3/ $\overline{\text{OC3}}$ input or they can be disabled by applying logic high. In the disabled state the LVDS outputs are internally terminated with an integrated 100 Ω resistor (two 50 Ω resistors connected in series). The middle point of these resistors is internally biased from a 1.25 V LVDS bias source.
32	GND	Ground
33	NC	No internal bonding Connection. Leave unconnected.

Pin Description (continued)

Pin #	Name	Description
34	Tdo	IEEE1149.1a Test Data Output (CMOS output). JTAG serial data is output on this pin on the falling edge of Tclk clock. If not used, this pin should be left unconnected.
35	Tms	IEEE1149.1a Test Mode Selection (3.3 V input). JTAG signal that controls the state transition on the TAP controller. This pin is internally pulled up to VDD. If not used, this pin should be left unconnected.
36	Tclk	IEEE1149.1a Test Clock Signal (5 V tolerant input). Input clock for the JTAG test logic. If not used, this pin should be pulled up to VDD.
37	$\overline{\text{Trst}}$	IEEE1149.1a Reset Signal (3.3 V input). Asynchronous reset for the JTAG TAP controller. This pin should be pulsed low on power-up to ensure that the device is in the normal functional state. This pin is internally pulled up to VDD. If this pin is not used then it should be connected to GND.
38	Tdi	IEEE1149.1a Test Data Input (3.3 V input). Input for JTAG serial test instructions and data. This pin is internally pulled up to VDD. If not used, this pin should be left unconnected.
39	NC	No internal bonding Connection. Leave unconnected.
40	NC	No internal bonding Connection. Leave unconnected.
41	PRIOR	Primary Reference Out of Range (Output). Logic high at this pin indicates that the Primary Reference is off the PLL centre frequency by more than ± 12 ppm. These thresholds support Stratum 3 applications. See PRIOR bit description in Status Register 1 for details.
42	C1.5o	Clock 1.544 MHz (CMOS tristate output). This output provides a 1.544 MHz DS1 rate clock.
43	C6o	Clock 6.312 MHz (CMOS tristate output). This output provides a 6.312 MHz DS2 rate clock.
44	IC	Internal Connection. Connect this pin to Ground.
45	GND	Ground
46	C19o	Clock 19.44 MHz (CMOS tristate output). This output provides a 19.44 MHz clock.
47	RefSel	Reference Source Select (Input). A logic low selects the PRI (primary) reference source as the input reference signal and logic high selects the SEC (secondary) input. The logic level at this input is sampled at the rising edge of F8o. This pin is internally pulled down to GND.
48	$\overline{\text{RefAlign}}$	Reference Alignment (Input). In Hardware Control pulling this pin low for 250 μ s initiates phase realignment between the input reference and the generated output clocks. This pin should never be tied low permanently. Please see Section 2.2.5, Reference Alignment (RefAlign) for more information. Internally this pin is pulled down to GND.

Pin Description (continued)

Pin #	Name	Description
49	VDD	Positive Power Supply
50	NC	No internal bonding Connection. Leave unconnected.
51	C20i	Clock 20 MHz (5 V tolerant input). This pin is the input for the 20 MHz Master Clock Oscillator. The clock oscillator should be connected directly (not AC coupled) to the C20i input and it must supply clock with duty cycle that is not worse than 40/60%.
52	GND	Digital Ground
53	C34/C44	Clock 34.368 MHz / clock 44.736 MHz (CMOS Output). This clock is programmable to be either 34.368 MHz (for E3 applications) or 44.736 MHz (for DS3 applications) when $\overline{\text{E3DS3/OC3}}$ is high, or to be either 8.592 MHz or 11.184 MHz when $\overline{\text{E3DS3/OC3}}$ is low. See description of $\overline{\text{E3DS3/OC3}}$ and $\overline{\text{E3/DS3}}$ inputs for details. In Software Control the functionality of this output is controlled by Control Register 2 (Table 8 "Control Register 2 (R/W)").
54	VDD	Positive Power Supply
55	HOLDOVER	Holdover Indicator (CMOS output). Logic high at this output indicates that the device is in Holdover mode.
56	NC	No internal bonding Connection. Leave unconnected.
57	LOCK	Lock Indicator (CMOS output). Logic high at this output indicates that ZL30407 is locked to the input reference. See LOCK bit description in Status Register 1 and Section 2.2.4, Lock Indicator (LOCK) for details.
58	NC	No internal bonding Connection. Leave unconnected.
59	$\overline{\text{DS}}$	Data Strobe (5 V tolerant input). This input is the active low data strobe of the processor interface.
60	IC	Internal Connection. Connect to ground.
61	SECOR	Secondary Reference Out of Range (Output). Logic high at this pin indicates that the Secondary Reference is off the PLL centre frequency by more than ± 12 ppm. These thresholds support Stratum 3 applications. See SECOR bit description in Status Register 1 for details.
62	OE	Output Enable (Input). Logic high on this input enables C19, $\overline{\text{F16}}$, $\overline{\text{C16}}$, C8, C6, C4, C2, C1.5, F8 and F0 signals. Pulling this input low will force the output clocks pins into a high impedance state.
63	$\overline{\text{CS}}$	Chip Select (5 V tolerant input). This active low input enables the microprocessor interface. When $\overline{\text{CS}}$ is set to high, the microprocessor interface is idle and all Data Bus I/O pins will be in a high impedance state.

Pin Description (continued)

Pin #	Name	Description
64	$\overline{\text{RESET}}$	RESET (5 V tolerant input). The ZL30407 must be reset after power-up in order to set internal registers into a default state. The internal reset is performed by forcing $\overline{\text{RESET}}$ pin low for a minimum of 1 μs after the C20 Master Clock is applied to pin C20i. This operation forces the ZL30407 internal state machine into a $\overline{\text{RESET}}$ state for a duration of 625 μs .
65	HW	Hardware/Software Control (Input). If this pin is tied low, the ZL30407 is controlled via the microport. If it is tied high, the ZL30407 is controlled via the control pins MS1, MS2, FCS, RefSel, RefAlign, E3/DS3 and E3DS3/OC3.
66-69	D0 - D3	Data 0 to Data 3 (5 V tolerant three-state I/O). These ports combined with D4 - D7 ports form the bi-directional data bus of the microprocessor interface (D0 is the least significant bit).
70	GND	Ground
71	IC	Internal Connection (Input). Connect this pin to ground.
72	IC	Internal Connection (Input). Connect this pin to ground.
73	VDD	Positive Power Supply
74 - 77	D4 - D7	Data 4 to Data 7 (5 V tolerant three-state I/O). These ports combined with D0 - D3 ports form the bi-directional data bus of the processor interface (D7 is the most significant bit).
78	$\overline{\text{R/W}}$	Read/Write Strobe (5 V tolerant input). This input controls the direction of the data bus D[0-7] during a microprocessor access. When $\overline{\text{R/W}}$ is high, the parallel processor is reading data from the ZL30407. When low, the parallel processor is writing data to the ZL30407.
79	A0	Address 0 (5 V tolerant input). Address input for the microprocessor interface. A0 is the least significant input.
80	IC	Internal Connection (Input). Connect this pin to ground.

2.0 Functional Description

The ZL30407 is a Network Element PLL designed to provide timing for SDH and SONET equipment conforming to ITU-T, ANSI, ETSI and Telcordia recommendations. In addition, it generates clocks for legacy PDH equipment operating at DS1, DS2, DS3, E1, and E3 rates. The ZL30407 provides clocks for industry standard ST-BUS and GCI backplanes, and it also supports H.110 timing requirements. The functional block diagram of the ZL30407 is shown in Figure 1 "Functional Block Diagram" and its operation is described in the following sections.

2.1 Acquisition PLLs

The ZL30407 has two Acquisition PLLs for monitoring the availability and quality of the Primary (PRI) and Secondary (SEC) reference clocks. Each Acquisition PLL operates independently and locks to the falling edges of one of the three input reference frequencies: 8 kHz, 1.544 MHz, 2.048 MHz or to the rising edges of 19.44 MHz. The reference frequency is continuously measured and its current frequency can be determined from reading the Acquisition PLL Status Register bits InpFreq1 and InpFreq0 (see Table 17 "Primary Acquisition PLL Status Register (R)" and Table 18 "Secondary Acquisition PLL Status Register (R)").

The Primary and Secondary Acquisition PLLs are designed to provide status information that identifies two levels of reference clock quality. For clarity, only the Primary Acquisition PLL is referenced in the text, but the same applies to the Secondary Acquisition PLL.

- Reference frequency drifts more than ± 12 ppm. In response, the PRIOR (Primary Reference Out of Range) bit and pin change state to high, in conformance with Stratum 3 requirements defined in GR-1244-CORE. The PRIOR bit is part of Status Register 1 (Table 7 "Status Register 1 (R)").
- Reference frequency drifted more than ± 30000 ppm or that the reference has been lost completely. In response, the Primary Acquisition PLL enters its own Holdover mode and indicates this by asserting the HOLDOVER bit in the Primary Acquisition PLL Status Register (Table 17 "Primary Acquisition PLL Status Register (R)"). Entry into Holdover forces the Core PLL into the Auto Holdover state.

Outputs of both Acquisition PLLs are connected to a multiplexer (MUX), which allows selection of the desired reference. This multiplexer channels binary words to the Core PLL digital phase detector (instead of analog signals) which eliminates quantization errors and improves phase alignment accuracy. The bandwidth of the Acquisition PLL is much wider than the bandwidth of the following Core PLL. This feature allows cascading Acquisition and Core PLLs without altering the transfer function of the Core PLL.

2.2 Core PLL

The most critical element of the ZL30407 is its Core PLL, which generates a phase-locked clock, filters jitter and wander and suppresses input phase transients. All of these features are in agreement with international standards:

- G.813 Option 1 and 2 clocks for SDH equipment
- GR-253 for SONET Stratum 3 and SONET Minimum Clocks (SMC)
- GR-1244 for Stratum 3 Clock

The Core PLL supports three mandatory modes of operation: Free-run, Normal (Locked) and Holdover. Each of these modes places specific requirements on the building blocks of the Core PLL.

- In Free-run Mode, the Core PLL derives its output clock from the 20 MHz Master Clock Oscillator connected to pin C20i. The stability of the generated clocks remain the same as the stability of the Master Clock Oscillator.
- In Normal Mode, the Core PLL locks to one of the Acquisition PLLs. Both Acquisition PLLs provide preprocessed phase data to the Core PLL including detection of reference clock quality.
- In Holdover mode, the Core PLL generates a clock based on data collected from past reference signals. The Core PLL enters Holdover mode if the attached Acquisition PLL switches into the Holdover state or under external software or hardware control.

Some of the key elements of the Core PLL are shown in Figure 3 "Core PLL Functional Block Diagram".

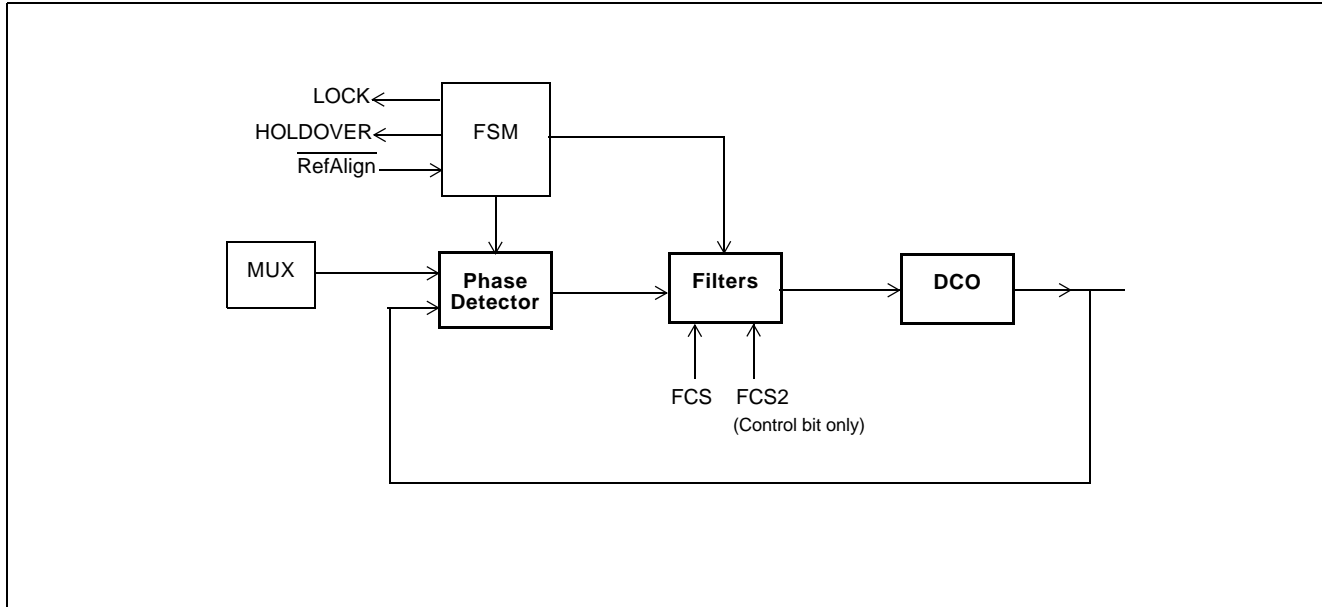

Figure 3 - Core PLL Functional Block Diagram

2.2.1 Digitally Controlled Oscillator (DCO)

The DCO is an arithmetic unit that continuously generates a stream of numbers that represent the phase-locked clock. These numbers are passed to the Clock Synthesizer (see section 2.3) where they are converted into electrical clock signals of various frequencies

2.2.2 Filters

In Normal mode, the clock generated by the DCO is phase-locked to the input reference signal and band-limited to meet network synchronization standards. The ZL30407 provides four software programmable (FCS bit in Control Reg 1 and FCS2 bit in Control Reg 3) and two hardware selectable (FCS pin) filtering options. The filtering characteristics are similar to a first order low pass filter with corner frequencies that support international standards:

FCS2 (bit)	FCS (pin/bit)	Filter	Conformance
0	0	1.5 Hz	Meets requirements of G.813 Option 1 and GR-1244 stratum 3 clocks. The maximum phase slope is limited to 41 ns in 1.326 ms.
0	1	0.1 Hz	Meets requirements of G.813 Option 2, GR-253 for SONET stratum 3 and GR-253 for SONET Minimum Clocks (SMC). The maximum phase slope is limited to 885 ns in one second.
1	0	12 Hz	There is no phase slope limiter active in this application.
1	1	6 Hz	Meets requirements of G.813 Option 1 for SDH Equipment Clocks (SEC) and GR-1244 for Stratum 4 and Stratum 4E clocks. The maximum phase slope is limited to 50 ns in 1.326 ms.

Table 1 - Loop Filter Selection

2.2.3 Phase Slope Limiters

Phase slope limiting is achieved by clamping the size of the error term from the phase detector. Limiting the size of the error term means that the output clocks move slowly in phase as the PLL aligns to phase transients on the input reference or transients caused by reference rearrangement. This increases the time required to achieve phase lock, but it is necessary to allow for downstream adjustments and so is called for in network standards such as G.813, GR-1244 and GR-253. Because the ZL30407 nulls out the phase offset between the output clocks and the selected reference upon reference rearrangement or return from holdover, the phase slope limiting feature will generally not come into play. If the pin RefAlign is pulled low to align the equivalent ZL30407 output clock to the selected reference, a large phase error will have to be corrected. In this case phase slope limiting will be active, limiting the output phase slope to 0.727 ppm for the 0.1 Hz filter mode, 31 ppm for the 1.5 Hz and the 6 Hz filter mode. In the 12 Hz mode there is no phase slope limiting. Consequently an output phase slope greater than 31 ppm may occur, for example, in locking to an orthogonal 8 kHz reference.

2.2.4 Lock Indicator (LOCK)

The ZL30407 is considered locked (LOCK = 1) when the residual phase movement after declaring locked condition does not exceed standard wander generation MTIE and TDEV tests. The ZL30407's phase locking mechanism allows it to lock within the specified locking times to references with a fractional frequency offset of up to ± 20 ppm. Locking time for different filters and pulling ranges is listed in "Performance Characteristics*" on page 49.

2.2.5 Reference Alignment (RefAlign)

When the ZL30407 finishes locking to a reference an arbitrary phase difference will remain between its output clocks and its reference; this phase difference is part of the normal operation of the ZL30407. If so desired, the output clocks can be brought into phase alignment with the PLL reference (see Figure 21 on page 47) by using the RefAlign control bit/pin.

2.2.5.1 Using RefAlign with 1.544 MHz, 2.048 MHz or 19.44 MHz Reference

If the ZL30407 is locked to a 1.544 MHz, 2.048 MHz or 19.44 MHz reference, then the output clocks can be brought into phase alignment with the PLL reference by using the RefAlign control bit/pin according to one of the procedures below:

1. For 0.1 Hz filtering applications (FCS = 1, FCS2 = 0)

- Wait until the ZL30407 LOCK indicator is high, indicating that it is locked
- Pull FCS low
- Pull Ref/Align low
- Hold RefAlign low for 250 μ s
- Pull RefAlign high
- Wait until the LOCK indicator goes high
- Pull FCS high

After initiating a reference realignment the PLL will enter Holdover mode for 200ns while aligning the internal clocks to remove the static phase error. The PLL will then begin the normal locking procedure. The LOCK pin will go low 5 sec after the reference realignment is initiated and will remain low for 10 sec.

2. For 1.5 Hz filtering applications (FCS = 0, FCS2 = 0)

- Wait until the ZL30407 LOCK indication is high, indicating that it is locked
- Pull RefAlign low
- Hold RefAlign low for 250 μ s
- Pull RefAlign high

After initiating a reference realignment the PLL will enter Holdover mode for 200ns while aligning the internal clocks to remove the static phase error. The PLL will then begin the normal locking procedure. The LOCK pin will go low 5 sec after the reference realignment is initiated and will remain low for 10 sec

3. For 6 Hz and 12 Hz filtering applications (FCS = 1, FCS2 = 1 or FCS = 0, FCS2 = 1)

- Wait until the ZL30407 LOCK indication is high, indicating that it is locked
- Pull RefAlign low
- Hold RefAlign low for 250 μ s
- Pull RefAlign high

After initiating a reference realignment the PLL will enter Holdover mode for 200 ns while aligning the internal clocks to remove the static phase error. The PLL will then begin the normal locking procedure. The LOCK pin will remain high during the realignment process.

2.2.5.2 Using RefAlign with an 8 kHz Reference

If the ZL30407 is locked to an 8 kHz reference, then the output clocks can be brought into phase alignment with the PLL reference by using the RefAlign control bit/pin according to one of the procedures below:

1. For 0.1 Hz filtering applications (FCS = 1, FCS2 = 0)

- Wait until the ZL30407 LOCK indicator is high, indicating that it is locked
- Pull FCS low
- Pull Ref/Align low
- Hold RefAlign low for 10 sec
- Pull RefAlign high
- Wait until the LOCK indicator goes high
- Pull FCS high

After initiating a reference realignment the PLL will enter Holdover mode for 200ns while aligning the internal clocks to remove the static phase error. The PLL will then begin the normal locking procedure. The LOCK pin will go low 5 sec after the reference realignment is initiated and will remain low for 10 sec.

2. For 1.5 Hz filtering applications (FCS = 0, FCS2 = 0)

- Wait until the ZL30407 LOCK indication is high, indicating that it is locked
- Pull RefAlign low
- Hold RefAlign low for 10 sec
- Pull RefAlign high

After initiating a reference realignment the PLL will enter Holdover mode for 200ns while aligning the internal clocks to remove the static phase error. The PLL will then begin the normal locking procedure. The LOCK pin will go low 5 sec after the reference realignment is initiated and will remain low for 10 sec.

3. For 6 Hz and 12 Hz filtering applications (FCS = 1, FCS2 = 1 or FCS = 0, FCS2 = 1)

- Wait until the ZL30407 LOCK indication is high, indicating that it is locked
- Pull RefAlign low
- Hold RefAlign low for 3 sec
- Pull RefAlign high

After initiating a reference realignment the PLL will enter Holdover mode for 200ns while aligning the internal clocks to remove the static phase error. The PLL will then begin the normal locking procedure. The LOCK pin will remain high during the realignment process.

2.3 Clock Synthesizer

The output of the Core PLL is connected to the Clock Synthesizer that generates twelve clocks and three frame pulses.

2.3.1 Output Clocks

The ZL30407 provides the following clocks (see Figure 18 "ST-BUS and GCI Output Timing", Figure 19 "DS1 and DS2 Clock Timing", Figure 20 "C155o and C19o Timing", and Figure 23 "E3 and DS3 Output Timing" for details):

- C1.5o : 1.544 MHz clock with nominal 50% duty cycle
- C2o : 2.048 MHz clock with nominal 50% duty cycle
- C4o : 4.096 MHz clock with nominal 50% duty cycle
- C6o : 6.312 MHz clock with nominal 50% duty cycle
- C8o : 8.192 MHz clock with nominal 50% duty cycle
- C8.5o : 8.592 MHz clock with duty cycle from 30 to 70%.
- C11o : 11.184 MHz clock with duty cycle from 30 to 70%.
- C16o : 16.384 MHz clock with nominal 50% duty cycle
- C19o : 19.44 MHz clock with nominal 50% duty cycle
- C34o : 34.368 MHz clock with nominal 50% duty cycle
- C44o : 44.736 MHz clock with nominal 50% duty cycle
- C155 : 155.52 MHz clock with nominal 50% duty cycle.

The ZL30407 provides the following frame pulses (see Figure 18 "ST-BUS and GCI Output Timing" for details). All frame pulses have the same 125 μ s period (8kHz frequency):

- F0o : 244 ns wide, logic low frame pulse
- F8o : 122 ns wide, logic high frame pulse
- F16o : 61 ns wide, logic low frame pulse

The combination of two pins, E3DS3/OC3 and E3/DS3, controls the selection of different clock configurations. When the E3DS3/OC3 pin is high then the C155o (155.52 MHz) clock is disabled and the C34/44 clock is output at its nominal frequency. The logic level on the E3/DS3 input determines if the output clock on the C34/44 output is 34.368 MHz (E3) or 44.736 MHz (DS3) (see Figure 4, "C34/C44, C155o Clock Generation Options," on page 17 for details).

		C34/44 Output		C155 Output	
		E3DS3/ $\overline{OC3}$		E3DS3/ $\overline{OC3}$	
		0	1	0	1
E3DS3	0	11.184	44.736	155.52 active	disabled
	1	8.592	34.368		

Figure 4 - C34/C44, C155o Clock Generation Options

All clocks and frame pulses (except the C155) are output with CMOS logic levels. The C155 clock (155.52 MHz) is output in a standard LVDS format.

2.3.2 Output Clocks Phase Adjustment

The ZL30407 provides three control registers dedicated to programming the output clock phase offset. Clocks $\overline{C16o}$, $\overline{C8o}$, $\overline{C4o}$ and $\overline{C2o}$ and frame pulses $\overline{F16o}$, $\overline{F8o}$, $\overline{F0o}$ are derived from 16.384 MHz and can be jointly shifted with respect to an active reference clock by up to 125 μ s with a step size of 61 ns. The required phase shift of clocks is programmable by writing to the Phase Offset Register 2 ("Table 9") and to the Phase Offset Register 1 ("Table 10"). The C1.5o clock can be shifted as well in step sizes of 81 ns by programming C1.5POA bits in Control Register 3 ("Table 12").

The coarse phase adjustment is augmented with a very fine phase offset control on the order of 477 ps per step. This fine adjustment is programmable by writing to the Fine Phase Offset Register (Table 16 "Fine Phase Offset Register (R/W)"). The offset moves all clocks and frame pulses generated by ZL30407 including the C155 clock.

2.4 Control State Machine

2.4.1 Clock Modes

Any Network Element that operates in a synchronous network must support three Clock Modes: Free-run, Normal (Locked) and Holdover. A network clock will usually operate in Normal mode. The Holdover and Free-run modes are used to cope with impairments in the synchronization hierarchy. Requirements for Clock Modes are defined in the international standards e.g.: G.813, GR-1244-CORE and GR-253-CORE and they are enforced by network operators. The ZL30407 supports all clock modes and each of these modes have a corresponding state in the Control State Machine.

2.4.2 ZL30407 State Machine

The ZL30407 Control State Machine is a combination of many internal states supporting the three mandatory clock modes. A simplified version of this state machine is shown in Figure 5; it includes the mandatory states: Free-run, Normal and Holdover. These three states are complemented by two additional states: Reset and Auto Holdover, which are critical to the ZL30407 operation under changing external conditions.

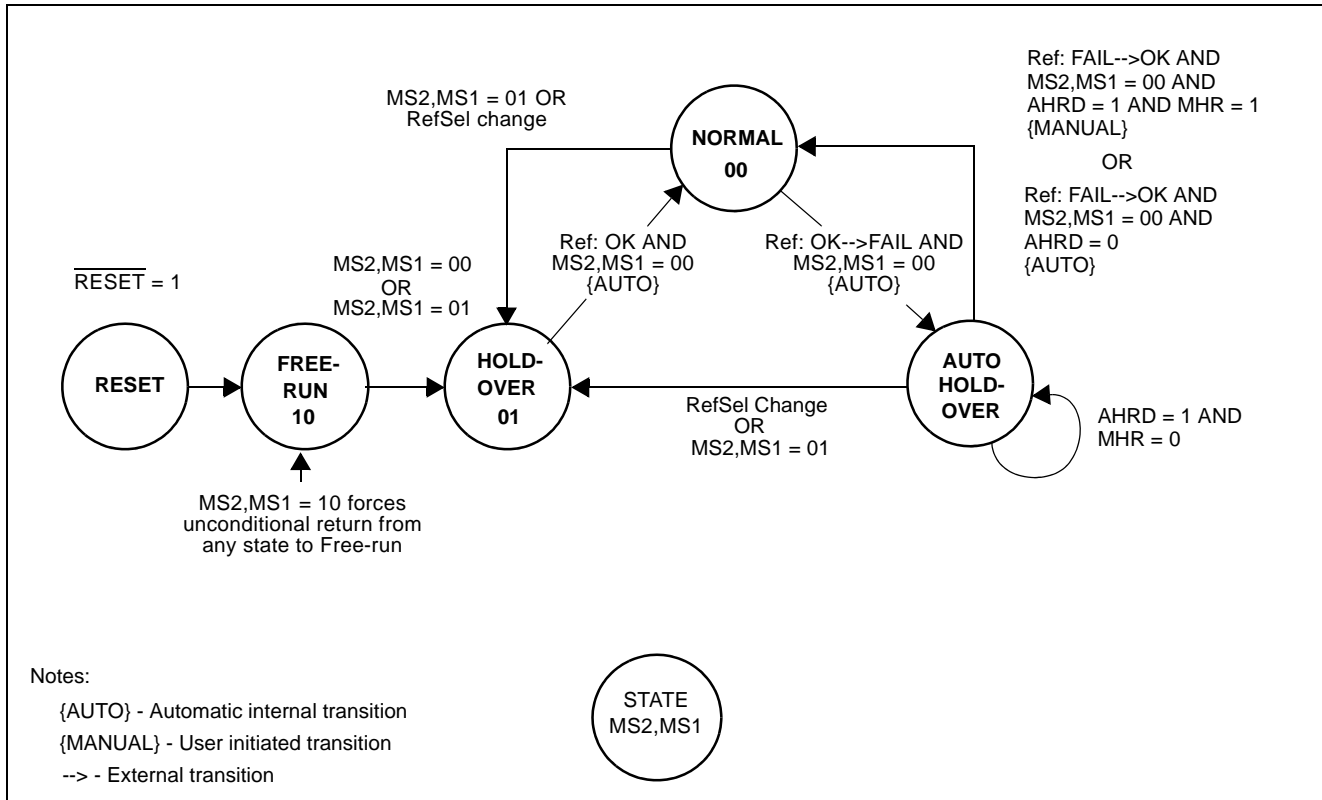

Figure 5 - ZL30407 State Machine in Software Control configuration

2.4.2.1 Reset State

The Reset State must be entered when ZL30407 is powered-up. In this state, all arithmetic calculations are halted, clocks are stopped, the microprocessor port is disabled and all internal registers are reset to their default values. The Reset state is entered by pulling the RESET pin low for a minimum of μs . When the RESET pin is pulled back high, internal logic starts a 625 μs initialization process before switching into the Free-run state ($\text{MS2, MS1} = 10$).

2.4.2.2 Free-Run State (Free-Run mode)

The Free-run state is entered when synchronization to the network is not required or is not possible. Typically this occurs during installation, repairs or when a Network Element operates as a master node in an isolated network. In the Free-run state, the accuracy of the generated clocks is determined by the accuracy and stability of the ZL30407 Master Crystal Oscillator. When equipment is installed for the first time (or periodically maintained) the accuracy of the Free-run clocks can be adjusted to within 1×10^{-12} by setting the offset frequency in the Master Clock Frequency Calibration Register.

2.4.2.3 Normal State (Normal Mode or Locked Mode)

The Normal State is entered when a good quality reference clock from the network is available for synchronization. The ZL30407 automatically detects the frequency of the reference clock (8 kHz, 1.544 MHz, 2.048 MHz or 19.44 MHz) and sets the LOCK status bit and pin high after acquiring synchronization. In the Normal state all generated clocks ($\overline{\text{C1.5o}}$, $\overline{\text{C2o}}$, $\overline{\text{C4o}}$, $\overline{\text{C6o}}$, $\overline{\text{C8o}}$, $\overline{\text{C16o}}$, $\overline{\text{C19o}}$, $\overline{\text{C34/C44}}$ and $\overline{\text{C155}}$) and frame pulses ($\overline{\text{F0o}}$, $\overline{\text{F8o}}$, $\overline{\text{F16o}}$) are derived from network timing. To guarantee uninterrupted synchronization, the ZL30407 has two Acquisition PLLs that continuously monitor the quality of the incoming reference clocks. This dual architecture enables quick replacement of a poor or failed reference and minimizes the time spent in other states.

2.4.2.4 Holdover State (Holdover Mode)

The Holdover State is typically entered for short durations while network synchronization is temporarily disrupted. In Holdover Mode, the ZL30407 generates clocks, which are not locked to an external reference signal but their frequencies are based on stored coefficients in memory that were determined while the PLL was in Normal Mode and locked to an external reference signal.

The initial frequency offset of the ZL30407 in Holdover Mode is 4×10^{-12} (see table Performance Characteristics* on page 49 for details). This is more accurate than Telcordia’s GR-1244-CORE Stratum 3E requirement of $\pm 1 \times 10^{-9}$. Once the ZL30407 has transitioned into Holdover Mode, holdover stability is determined by the stability of the 20 MHz Master Clock Oscillator. Selection of the oscillator requires close examination of the crystal oscillator temperature sensitivity and frequency drift caused by aging.

2.4.2.5 Auto Holdover State

The Auto Holdover state is a transitional state that the ZL30407 enters automatically when the active reference fails unexpectedly. When the ZL30407 detects loss of reference it sets the HOLDOVER status bit and waits in Auto Holdover state until the failed reference recovers. Recovery from Auto Holdover for 8 kHz, 1.544 MHz, 2.048 MHz and 19.44 MHz reference clocks is fully automatic, however recovery for an 8 kHz reference clock requires additional transitioning through the Holdover state to guarantee compliance with network synchronization standards (for details see Section 4.1.3 on page 36 and Section 4.1.2 on page 35). The HOLDOVER status may alert the control processor about the failure and in response the control processor may switch to the secondary reference clock. The Auto Holdover and Holdover States are internally combined together and they are output as a HOLDOVER status on pin 55 and bit 4 in Status Register 1 (Table 7 on page 26).

In less demanding clocking arrangements (e.g. Line Cards), the ZL30407 can be configured to operate in the Hardware Control mode which does not require a microprocessor. Under the Hardware Control mode the ZL30407 maintains most of its State Machine functionality as is shown in Figure 6.

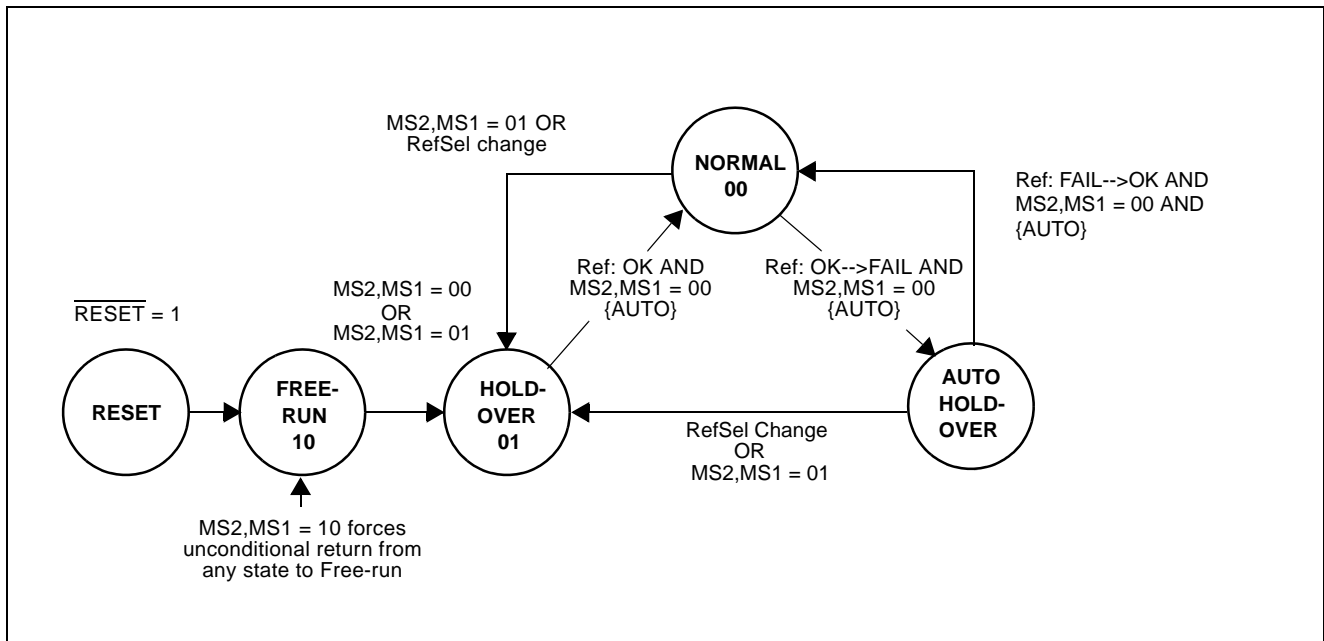

Figure 6 - ZL30407 State Machine in Hardware Control configuration

2.4.3 State Transitions

In a typical Network Element application, the ZL30407 will most of the time operate in Normal mode (MS2, MS1 == 00) generating synchronous clocks. Its two Acquisition PLLs will continuously monitor the input references for signs of degraded quality and output status information for further processing. The status information from the Acquisition PLLs and the CORE PLL combined with status information from line interfaces and framers (as listed below) forms the basis for creating reliable network synchronization.

- Acquisition PLLs (PRIOR, SECOR, PAH, PAFL, SAH, SAFL)
- Core PLL (LOCK, HOLDOVER, FLIM)
- Line interfaces (e.g. LOS - Loss of Signal, AIS - Alarm Indication Signal)
- Framers (e.g. LOF - Loss of frame or Synchronization Status Messages carried over SONET S1 byte or ESF-DS1 Facility Data Link).

The ZL30407 State Machine is designed to perform some transitions automatically, leaving other less time dependent tasks to the control processor. The state machine includes two stimulus signals which are critical to automatic operation: "OK --> FAIL" and "FAIL --> OK" that represent loss (and recovery) of reference signal or its drift by more than ± 30000 ppm. Both of them force the Core PLL to transition into and out of the Auto Holdover state. In case when the reference clock on the PRI (or SEC) input is externally selected from multiple clock sources with different frequencies then the Acquisition PLL will automatically detect this change as a reference clock failure. In response, the Acquisition PLL will force Core PLL into Auto-Holdover state until the frequency of a new reference is determined. This process may take up to 35 ms after which a normal locking procedure will be initiated.

The ZL30407 State Machine is controlled by the mode select pins or bits MS2, MS1. In order to avoid network synchronization problems, the State Machine has built-in basic protection that does not allow switching the Core PLL into a state where it cannot operate correctly e.g., it is not possible to force the Core PLL into Normal mode when all references are lost.

2.5 Master Clock Frequency Calibration Circuit

In an ordinary timing generation module, the Free-run mode accuracy of generated clocks is determined by the accuracy of the Master Crystal Oscillator. If the Master Crystal Oscillator has a manufacturing tolerance of ± 4.6 ppm, the generated clocks will have no better accuracy.

The ZL30407 eliminates Crystal Oscillator tolerance problem by providing a programmable Master Clock Frequency Calibration circuit, which can reduce oscillator manufacturing tolerance to near zero. However this feature does not eliminate oscillator frequency drift. The value stored in the Master Clock Calibration Register can be periodically updated to compensate for oscillator frequency drift due to ageing or due to temperature effects. The compensation value for the Master Clock Calibration Register (MCFC3 to MCFC0) can be calculated from the following equation:

$$\text{MCFC} = 45036 * (-f_{\text{offset}}) \text{ where: } f_{\text{offset}} = f_m - 20\,000\,000 \text{ Hz}$$

The f_m frequency should only be measured after the Master Crystal Oscillator has been mounted inside a system and powered long enough for the Master Crystal Oscillator to reach a steady operating temperature. Section 4.3 on page 40 provides two examples of how to calculate an offset frequency and convert the decimal value to a binary format. The maximum frequency compensation range of the MCFC register is equal to ± 2384 ppm (± 47680 Hz).

Changes to the Master Clock Calibration Register cause immediate changes in the frequency of the output clocks. Care should be taken to ensure that changes to the Master Clock Calibration Register are made in small increments so the frequency steps can be tolerated by downstream equipment. A rate of frequency change below 2.9 ppm/sec is suggested.

All memory in the ZL30407 is volatile; so any settings of the Master Clock Calibration Register need to be reloaded after each RESET.

2.6 Microprocessor Interface

The ZL30407 can be controlled by a microprocessor or by an ASIC type of device that is connected directly to the hardware control pins. If the HW pin is tied low (see Figure 7 "Hardware and Software Control Options"), an 8-bit Motorola type microprocessor may be used to control PLL operation and check its status. Under software control, the control pins MS2, MS1, FCS, RefSel, RefAlign are disabled and they are replaced by the equivalent control bits. The output pins LOCK, HOLDOVER, PRIOR and SECOR are always active and they provide current status information whether the device is in microprocessor or hardware control. Software (microprocessor) control provides additional functionality that is not available in hardware control such as:

- 6 Hz and 12 Hz PLL loop filter selection
- output clock phase adjustment
- master clock frequency calibration
- extended access to status registers. These registers are also accessible when the ZL30407 operates under Hardware control.

2.7 JTAG Interface

The ZL30407 JTAG (Joint Test Action Group) interface conforms to the Boundary-Scan standard IEEE1149.1-1990, which specifies a design-for-testability technique called Boundary-Scan Test (BST). The BST architecture is made up of four basic elements, Test Access Port (TAP), TAP Controller, Instruction Register (IR) and Test Data Registers (TDR) and all these elements are implemented on the ZL30407.

Zarlink Semiconductor provides a Boundary Scan Description Language (BSDL) file that contains all the information required for a JTAG test system to access the ZL30407's boundary scan circuitry. The file is available for download from the Zarlink Semiconductor web site: www.zarlink.com.

3.0 Hardware and Software Control

The ZL30407 offers Hardware and Software Control options that simplify the design of basic or complex clock synchronization modules. Hardware control offers fewer features but still allows for building of sophisticated timing cards without extensive programming. The complete set of control and status functions for each mode are shown in Figure 7 "Hardware and Software Control Options".

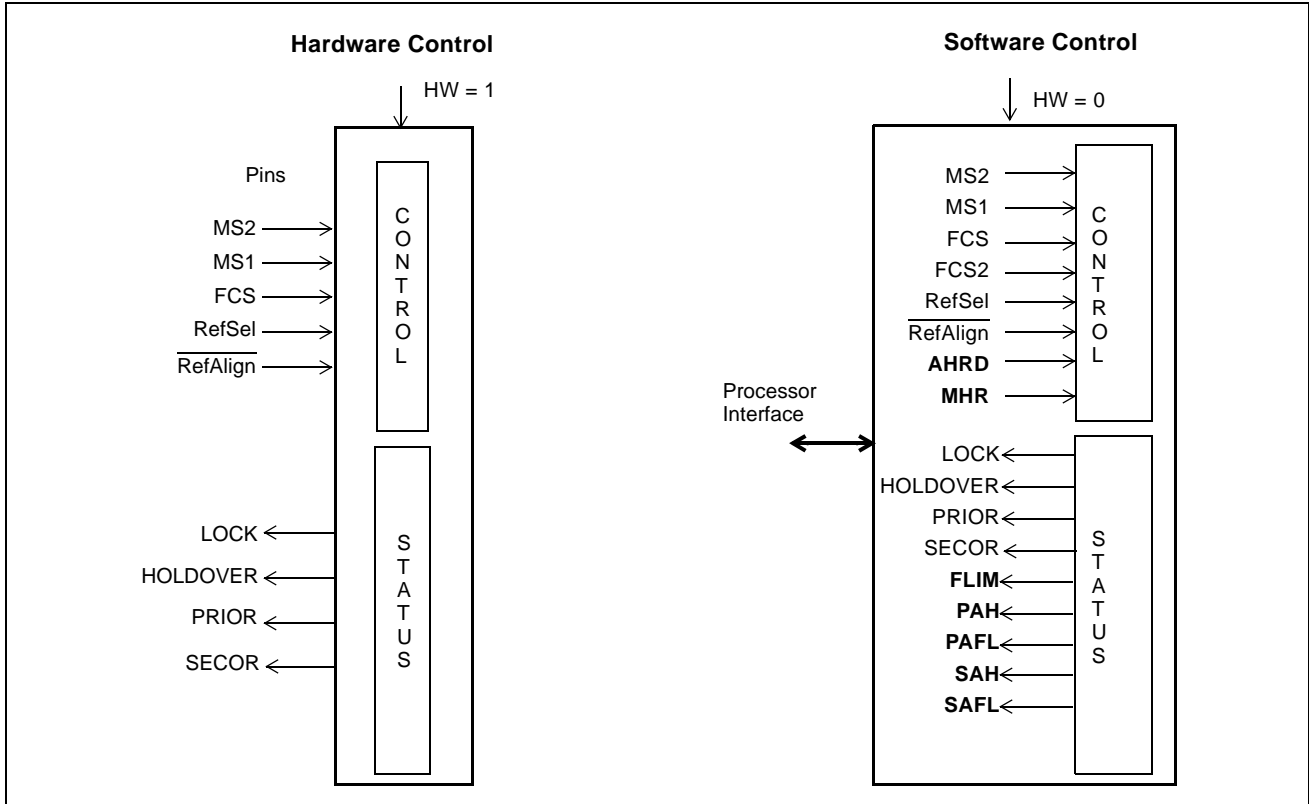

Figure 7 - Hardware and Software Control Options

3.1 Hardware Control

The Hardware control is a subset of software control and it will only be briefly described with cross-referencing to Software control programmable registers.

3.1.1 Control Pins

The ZL30407 has five dedicated control pins for selecting modes of operation and activating different functions. These pins are listed below:

MS2 and MS1 pins: Mode Select: The MS2 (pin 19) and MS1 (pin 18) inputs select the PLL mode of operation. See Table 2 for details. The logic level at these inputs is sampled by the rising edge of the F8o frame pulse.

MS2	MS1	Mode of Operation
0	0	Normal mode
0	1	Holdover mode
1	0	Free-run
1	1	Reserved

Table 2 - Operating Modes and States

FCS pin: Filter Characteristic Select. The FCS (pin 9) input is used to select the filtering characteristics of the Core PLL. See Table 1, "Loop Filter Selection" on page 13 for details.

FCS	Filtering Characteristic
0	Filter corner frequency set to 1.5 Hz
1	Filter corner frequency set to 0.1 Hz

Table 3 - Filter Characteristic Selection

RefSel: Reference Source Select. The RefSel (pin 47) input selects the PRI (primary) or SEC (secondary) input as the reference clock for the Core PLL. The logic level at this input is sampled by the rising edge of F8o.

RefSel	Input Reference
0	Core PLL connected to the Primary Acquisition PLL
1	Core PLL connected to the Secondary Acquisition PLL

Table 4 - Reference Source Select

RefAlign: Reference Alignment. The RefAlign (pin 48) input controls phase realignment between the input reference and the generated output clocks.

3.1.2 Status Pins

The ZL30407 has four dedicated status pins for indicating modes of operation and quality of the Primary and Secondary reference clocks. These pins are listed below:

LOCK - This output goes high after the ZL30407 has completed its locking sequence (see section 2.2.3 for details).

HOLDOVER - This output goes high when the Core PLL enters Holdover mode. The Core PLL will switch to Holdover mode if the respective Acquisition PLL enters Holdover mode or if the mode select pins or bits are set to Holdover (MS2, MS1 = 01).

PRIOR - This output goes high when the primary reference frequency deviates from the PLL center frequency by more than ± 12 ppm. See PRIOR pin description for details.

SECOR - This output goes high when the secondary reference frequency deviates from the PLL center frequency by more than ± 12 ppm. See SECOR pin description for details.

3.2 Software Control

Software control is enabled by setting the HW pin to logic zero (HW = 0). In this mode all hardware control pins (inputs) are disabled and all status pins remain enabled. The ZL30407 has a number of registers that provide all the functionality available in Hardware control and in addition they offer advanced control and monitoring that is only available in Software control (see Figure 7 "Hardware and Software Control Options").

3.2.1 Control Bits

The ZL30407 has a number of registers that provide greater operational flexibility than available pins in Hardware control (see Figure 7 "Hardware and Software Control Options"). The MS2, MS1, FCS2, FCS, RefSel and RefAlign bits perform the same function as the corresponding pins. Two additional bits AHRD and MHR support recovery from Auto Holdover mode and they are described in section 3.2.4.

In addition to the Control bits shown in Figure 7 "Hardware and Software Control Options", the ZL30407 has a number of bits and registers that are accessed infrequently e.g., 6 Hz and 12 Hz PLL loop filter selection, Phase Offset Adjustment or Master Clock Frequency Calibration. These additional control options add flexibility to the ZL30407.

The ZL30407 has a number of status bits that provide more comprehensive monitoring of the internal operation than is available in Hardware control (see Figure 7 "Hardware and Software Control Options"). The HOLDOVER, PRIOR and SECOR bits perform the same function as their equivalent status pins. The function of the LOCK status bit is not identical to the function of the LOCK status pin, see the description of the LOCK status bit and the FLIM status bit for details. The FLIM bit indicates that the output frequency of the Core PLL has reached its upper or lower limit. The PAH and SAH status bit show entry of the Primary and Secondary acquisition PLLs into Holdover mode. See section 3.2.4 for detailed description of the status bits. Under software control, the status pins are always enabled and they can be used to trigger hardware interrupts.

3.2.2 ZL30407 Register Map

Addresses: 00H to 6FH

Address hex	Register	Read Write	Function
00	Control Register 1	R/W	RefSel, 0, 0, MS2, MS1, FCS, 0, RefAlign
01	Status Register 1	R	PRIOR, SECOR, LOCK, HOLDOVER, rsv, FLIM, rsv, rsv
04	Control Register 2	R/W	E3DS3/OC3, E3/DS3, 0, 0, 0, 0, 0, 0,
06	Phase Offset Register 2	R/W	0, 0, 0, 0, OffEn, C16POA10, C16POA9, C16POA8
07	Phase Offset Register 1	R/W	C16POA7, C16POA6, C16POA5, C16POA4, C16POA3, C16POA2, C16POA1, C16POA0
0F	Device ID Register	R	0111 0000
11	Control Register 3	R/W	rsv, rsv, C1.5POA2, C1.5POA1, C1.5POA0, 0, 0, FCS2
13	Clock Disable Register 1	R/W	0, 0, C16dis, C8dis, C4dis, C2dis, C1.5dis,0
14	Clock Disable Register 2	R/W	0, 0, 0, F8odis, F0odis, F16odis, C6dis, C19dis
19	Core PLL Control Register	R/W	0, 0, 0, 0, 0, MHR, AHRD, 0
1A	Fine Phase Offset Register	R/W	FPOA7, FPOA6, FPOA5, FPOA4, FPOA3, FPOA2, FPOA1, FPOA0
20	Primary Acquisition PLL Status Register	R	rsv, rsv, rsv, InpFreq1, InpFreq0, rsv, PAH,PAFL
28	Secondary Acquisition PLL Status Register	R	rsv, rsv, rsv, InpFreq1, InpFreq0, rsv, SAH, SAFL
40	Master Clock Frequency Calibration Register - Byte 4	R/W	MCFC31, MCFC30, MCFC29, MCFC28, MCFC27, MCFC26, MCFC25, MCFC24,
41	Master Clock Frequency Calibration Register - Byte 3	R/W	MCFC23, MCFC22, MCFC21, MCFC20, MCFC19, MCFC18, MCFC17, MCFC16
42	Master Clock Frequency Calibration Register - Byte 2	R/W	MCFC15, MCFC14, MCFC13, MCFC12, MCFC11, MCFC10, MCFC9, MCFC8
43	Master Clock Frequency Calibration Register - Byte 1	R/W	MCFC7, MCFC6, MCFC5, MCFC4, MCFC3, MCFC2, MCFC1, MCFC0

Table 5 - ZL30407 Register Map

Note: The ZL30407 uses address space from 00h to 6Fh. Registers at address locations not listed above must not be written or read.

3.2.3 Register Description

Address: 00 H

Bit	Name	Functional Description	Default
7	RefSel	Reference Select. A zero selects the PRI (Primary) reference source as the input reference signal and a one selects the SEC (secondary) reference.	0
6-5	RSV	Reserved	00
4-3	MS2, MS1	Mode Select <ul style="list-style-type: none"> - MS2 = 0 MS1 = 0 Normal Mode (Locked Mode) - MS2 = 0 MS1 = 1 Holdover Mode - MS2 = 1 MS1 = 0 Free-run Mode - MS2 = 1 MS1 = 1 Reserved 	10
2	FCS	Filter Characteristic Select (see Table 12 on page 29 for complimentary FCS2 bit description) <ul style="list-style-type: none"> - FCS2 = 0, FCS = 0 : Filter corner frequency set to 1.5 Hz. - FCS2 = 0, FCS = 1 : Filter corner frequency set to 0.1 Hz. - FCS2 = 1, FCS = 0 : Filter corner frequency set to 12 Hz. - FCS2 = 1, FCS = 1 : Filter corner frequency set to 6 Hz. <p>Conformance of these filter settings to standards is presented in Table 1, "Loop Filter Selection" on page 13.</p>	0
1	RSV	Reserved	0
0	$\overline{\text{RefAlign}}$	Reference Alignment. A high-to-low transition aligns the generated output clocks to the input reference signal (see Section 2.2.5, Reference Alignment (RefAlign) for details). This bit should never be held low permanently.	1

Table 6 - Control Register 1 (R/W)

Address: 01 H

Bit	Name	Functional Description
7	PRIOR	<p>Primary Reference Out of Range. This output goes high when:</p> <ul style="list-style-type: none"> the primary reference is off its nominal frequency by more than ± 12 ppm. The frequency offset monitor updates internally every 10 sec and will change state after two matching measurements (PASS/PASS or FAIL/FAIL). This is in full compliance with the GR-1244-CORE requirement of 10 to 30 sec Reference Validation Time. This output returns to zero when the reference frequency is requalified within ± 9.2 ppm of the nominal frequency (monitor circuit has built-in hysteresis). In an extreme case, when over time the Master Clock oscillator drifts ± 4.6 ppm the switching thresholds will change as well, as is shown in Figure 8. the reference impairment detector detects large frequency offset (greater than 3%) or large change in a single cycle period (greater than 30%). In both cases detector will disqualify the reference and reset the 10 sec internal timer.
6	SECOR	<p>Secondary Reference Out of Range. Functionally, this bit is equivalent to the PRIOR bit for Primary Acquisition PLL.</p>
5	LOCK	<p>Lock. This bit goes high when the Core PLL completes the phase locking process to the input reference clock (see Section 2.2.4, Lock Indicator (LOCK) for details). After achieving lock, this bit will go low if the ZL30407 enters Holdover mode, Automatic Holdover mode or Free-run mode, or if the Core PLL phase detector accumulates more than 22 μs of phase error, or if the RefAlign control bit/pin is taken low.</p> <p>Note that the indication of the LOCK status pin is a logical combination of the LOCK status bit and the FLIM status bit. Please see the FLIM status bit description.</p>
4	HOLDOVER	<p>Holdover. This bit goes high when the Core PLL enters Holdover mode. Detection of reference failure and subsequent transition from Normal to Holdover mode takes approximately: 0.75 μs for 19.44 MHz reference, 0.85 μs for 2.048 MHz reference, 1.5 μs for 1.544 MHz reference and 130 μs for 8 kHz reference.</p>
3	RSV	Reserved
2	FLIM	<p>Frequency Limit. This bit goes high when the Core PLL is pulled by the input reference signal to the edge of its frequency tracking range set at ± 104 ppm. This bit may change state momentarily in the event of large jitter or wander excursions occurring when the input reference is close to the frequency limit range.</p> <p>When the FLIM bit goes high it will cause the LOCK status pin to go low, but it will not cause the LOCK status bit to go low.</p>
1	RSV	Reserved
0	RSV	Reserved

Table 7 - Status Register 1 (R)

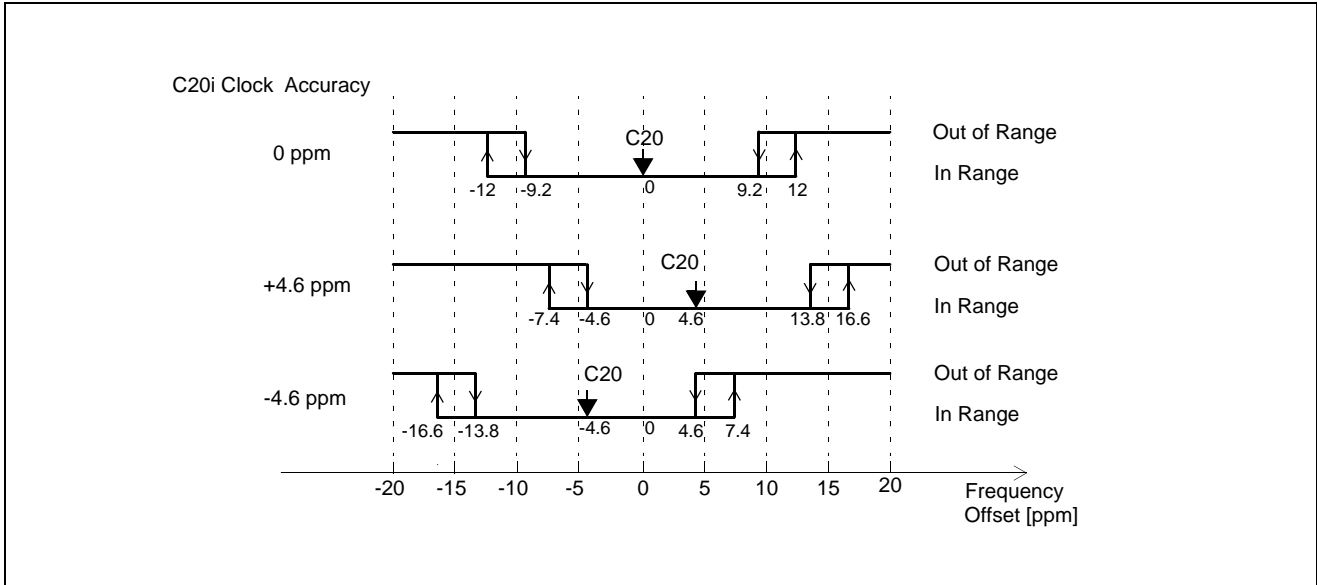

Figure 8 - Primary and Secondary Reference Out of Range Thresholds

Address: 04 H

Bit	Name	Functional Description	Default
7	E3DS3/ $\overline{\text{OC3}}$	E3, DS3 or OC-3 clock select. Setting this bit to zero enables the C155P/N outputs (pin 30 and pin 31) and enables the C34/C44 output (pin 53) to provide C8 or C11 clocks. Logic high disables the C155 clock LVDS outputs and enables the C34/C44 output to provide a C34 or C44 clock.	0
6	E3/ $\overline{\text{DS3}}$	E3 or DS3 clock select. When E3DS3/ $\overline{\text{OC3}}$ bit is set high, a logic low on the E3/ $\overline{\text{DS3}}$ bit selects a 44.736 MHz clock on the C34/C44 output and logic high selects a 34.368 MHz clock. When the E3DS3/ $\overline{\text{OC3}}$ bit is set low, a logic low on the E3/ $\overline{\text{DS3}}$ bit selects an 11.184 MHz clock on the C34/C44 output and a logic high selects an 8.592 MHz clock.	0
5-0	RSV	Reserved	000000

Table 8 - Control Register 2 (R/W)

Address: 06 H

Bit	Name	Functional Description	Default
7-4	RSV	Reserved	0000
3	OffEn	Offset Enable. Set high to enable programmable phase offset adjustment (C16 Phase Offset Adjustment and C1.5 Phase Offset Adjustment) between the input reference and the generated clocks.	0
2 - 0	C16POA10 to C16POA8	C16 Phase Offset Adjustment. These three bits (most significant) in conjunction with the eight bits of Phase Offset Register 1 allow for <u>phase shifting of all clocks and frame pulses</u> that are derived from the C16 clock (C8o, C4o, C2o, F16o, F8o, F0o). The phase offset is an unsigned number in a range from 0 to 2047. Each increment by one represents a phase-offset advancement by 61.035 ns with respect to the input reference signal. The phase offset is a two-byte value and it must be written in one step increments. For example: four writes are required to advance clocks by 244 ns from its current position of 22H: write 23H, 24H, 25H, 26H. Writing numbers in reverse order will delay clocks from their present position. Note that phase offset adjustment is a process of shifting clocks in a time domain which may cause momentary distortion of the generated clocks. Therefore it is not recommended to perform phase offset adjustments on an active ZL30407 (at the time when it generates network clocks).	000

Table 9 - Phase Offset Register 2 (R/W)

Address: 07 H

Bit	Name	Functional Description	Default
7-0	C16POA7 to C16POA0	C16 Phase Offset Adjustment. The eight least significant bits of the phase offset adjustment word. See the Phase Offset Register 2 for details.	0000 0000

Table 10 - Phase Offset Register 1 (R/W)

Address: 0F H

Bit	Name	Functional Description
7-4	ID7 - 4	Device Identification Number. These four bits represent the device part number. The ID number for ZL30407 is 0111.
3-0	ID3 - 0	Device Revision Number. These bits represent the revision number. Number starts from 0000.

Table 11 - Device ID Register (R)

Address: 11 H

Bit	Name	Functional Description	Default
7	RSV	Reserved	0
6	RSV	Reserved	0
5-3	C1.5POA2 to C1.5POA0	<p>C1.5 Phase Offset Adjustment. These three bits allow for changing of the phase offset of the C1.5o clock relative to the active input reference. The phase offset is an unsigned number in a range from 0 to 7. Each increment by one represents phase-offset advancement by 80.96 ns. Example: Writing 010 advances C1.5 clock by 162 ns. Successive writing of 001 delays this clock by 80.96 ns from its present position</p> <p>Note that phase offset adjustment is a process of shifting clocks in a time domain which may cause momentary distortion of the generated clocks. Therefore it is not recommended to perform phase offset adjustments on an active ZL30407 (at the time when it generates network clocks).</p>	000
2-1	RSV	Reserved	00
0	FCS2	<p>Filter Characteristic Select 2 (see Table 6 on page 25 for complimentary FCS bit description)</p> <ul style="list-style-type: none"> - FCS2 = 0, FCS = 0 : Filter corner frequency set to 1.5 Hz - FCS2 = 0, FCS = 1 : Filter corner frequency set to 0.1 Hz - FCS2 = 1, FCS = 0 : Filter corner frequency set to 12 Hz - FCS2 = 1, FCS = 1 : Filter corner frequency set to 6 Hz <p>Conformance of these filter settings to standards is presented in Table 1, "Loop Filter Selection" on page 13.</p>	0

Table 12 - Control Register 3 (R/W)

Address: 13 H

Bit	Name	Functional Description	Default
7	RSV	Reserved	0
6	RSV	Reserved	0
5	C16dis	16.384 MHz Clock Disable. When set high, this bit tristates the 16.384 MHz clock output.	0
4	C8dis	8.192 MHz Clock Disable. When set high, this bit tristates the 8.192 MHz clock output.	0
3	C4dis	4.096 MHz Clock Disable. When set high, this bit tristates the 4.096 MHz clock output.	0
2	C2dis	2.048 MHz Clock Disable. When set high, this bit tristates the 2.048 MHz clock output.	0
1	C1.5dis	1.544 MHz Clock Disable. When set high, this bit tristates the 1.544 MHz clock output.	0
0	RSV	Reserved	0

Table 13 - Clock Disable Register 1 (R/W)

Address: 14 H

Bit	Name	Functional Description	Default
7-5	RSV	Reserved	000
4	F8odis	F8o Frame Pulse Disable. When set high, this bit tristates the 8 kHz 122 ns active high framing pulse output.	0
3	F0odis	F0o Frame Pulse Disable. When set high, this bit tristates the 8 kHz 244 ns active low framing pulse output.	0
2	F16odis	F16o Frame Pulse Disable. When set high, this bit tristates the 8 kHz 61 ns active low framing pulse output.	0
1	C6dis	6.312 MHz Clock Disable. When set high, this bit tristates the 6.312 MHz clock output.	0
0	C19dis	19.44 MHz Clock Disable. When set high, this bit tristates the 19.44 MHz clock output.	0

Table 14 - Clock Disable Register 2 (R/W)

Address: 19 H

Bit	Name	Functional Description	Default
7-3	RSV	Reserved	00000
2	MHR	Manual Holdover Release. A change from 0 to 1 on the MHR bit will release the Core PLL from Auto Holdover when automatic return from Holdover is disabled (AHRD is set to 1). This bit is level sensitive and it must be cleared immediately after it is set to 1 (next write operation). This bit has no effect if AHRD is set to 0.	0
1	AHRD	Automatic Holdover Return Disable. When set high, this bit inhibits the Core PLL from automatically switching back to Normal mode from Auto Holdover state when the active Acquisition PLL regains lock to its input reference. The active Acquisition PLL is the Acquisition PLL to which the Core PLL is currently connected. For the 8 kHz input reference, the recovery from Auto Holdover state must transition through the Holdover state to preserve "hit-less" recovery. To guarantee this transitioning, the AHRD bit should be set high permanently to prevent automatic return to Normal mode.	0
0	RSV	Reserved	0

Table 15 - Core PLL Control Register (R/W)

Address: 1A H

Bit	Name	Functional Description	Default
7-0	FPOA7 - 0	<p>Fine Phase Offset Adjustment. This register allows phase offset adjustment of all output clocks and frame pulses (C16o, C8o, C4o, C2o, F16o, F8o, F0o, C155, C19o, C34/44, C1.5o, C6o) relative to the active input reference. The adjustment can be positive (advance) or negative (delay) with a nominal step size of 477 ps (61.035 ns / 128). Changes to the offset values are filtered before they propagate to the PLL outputs. The rate of phase change is determined by the bandwidth of the selected filter and is limited to the level listed in the Table , "Performance Characteristics*" on page 49.</p> <p>The phase offset value is a signed 2's complement number e.g.: Advance: +1 step = 01H, +2 steps = 02H, +127 steps = EFH Delay: -1 step = FFH, -2 steps = FEH, -128 steps = 80H Example: Writing 08H advances all clocks by 3.8 ns and writing F3H delays all clocks</p>	00000 000

Table 16 - Fine Phase Offset Register (R/W)

Address: 20 H

Bit	Name	Functional Description
7-5	RSV	Reserved
4-3	InpFreq1-0	<p>Input Frequency. These two bits identify the Primary Reference Clock frequency.</p> <ul style="list-style-type: none"> - 00 = 19.44 MHz - 01 = 8 kHz - 10 = 1.544 MHz - 11 = 2.048 MHz
2	RSV	Reserved
1	PAH	<p>Primary Acquisition PLL Holdover. This bit goes high whenever the Acquisition PLL enters Holdover mode. Holdover mode is entered when the reference frequency is:</p> <ul style="list-style-type: none"> • lost completely • drifts more than $\pm 30\,000$ ppm off from the nominal frequency • a large phase hit occurs on the reference clock
0	PAFL	This status bit is intended to provide software compatibility with the ZL30402. It is not required for new designs.

Table 17 - Primary Acquisition PLL Status Register (R)

Address: 28 H

Bit	Name	Functional Description
7-5	RSV	Reserved
4-3	InpFreq1-0	Input Frequency. These two bits identify the Secondary Reference Clock frequency. <ul style="list-style-type: none"> - 00 = 19.44 MHz - 01 = 8 kHz - 10 = 1.544 MHz - 11 = 2.048 MHz
2	RSV	Reserved
1	SAH	Secondary Acquisition PLL Holdover. This bit goes high whenever the Acquisition PLL enters Holdover mode. Holdover mode is entered when reference frequency is: <ul style="list-style-type: none"> • lost completely • drifts more than $\pm 30\,000$ ppm off the nominal frequency • a large phase hit occurs on the reference clock
0	SAFL	This status bit is intended to provide software compatibility with the ZL30402. It is not required for new designs.

Table 18 - Secondary Acquisition PLL Status Register (R)

Address: 40 H

Bit	Name	Functional Description	Default
7-0	MCFC31 - 24	Master Clock Frequency Calibration. This most significant byte contains the 31st to 24th bit of the Master Clock Frequency Calibration Register. See Applications section 4.2 for a detailed description of how to calculate the MCFC value.	00000 000

Table 19 - Master Clock Frequency Calibration Register 4 (R/W)

Address: 41 H

Bit	Name	Functional Description	Default
7-0	MCFC23 - 16	Master Clock Frequency Calibration. This byte contains the 23rd to 16th bit of the Master Clock Frequency Calibration Register.	00000 000

Table 20 - Master Clock Frequency Calibration Register 3 (R/W)

Address: 42 H

Bit	Name	Functional Description	Default
7-0	MCFC15 - 8	Master Clock Frequency Calibration. This byte contains the 15th to 8th bit of the Master Clock Frequency Calibration Register.	00000 000

Table 21 - Master Clock Frequency Calibration Register 2 (R/W)

Address: 43 H

Bit	Name	Functional Description	Default
7-0	MCFC7 - 0	Master Clock Frequency Calibration. This byte contains bit 7 to bit 0 of the Master Clock Frequency Calibration Register.	00000 000

Table 22 - Master Clock Frequency Calibration Register 1 (R/W)

4.0 Applications

This section contains application specific details for Mode Switching and Master Clock Oscillator calibration.

4.1 ZL30407 Mode Switching - Examples

The ZL30407 is designed to transition from one mode to the other driven by the internal State Machine or by manual control. The following examples present a couple of typical scenarios of how the ZL30407 can be employed in network synchronization equipment (e.g. timing modules, line cards or stand alone synchronizers).

4.1.1 System Start-up Sequence: FREE-RUN --> HOLDOVER --> NORMAL

The FREE-RUN to HOLDOVER to NORMAL transition represents a sequence of steps that will most likely occur during a new system installation or scheduled maintenance of timing cards. The process starts from the RESET state and then transitions to Free-run mode where the system (card) is being initialized. At the end of this process the ZL30407 should be switched into Normal mode (with MS2, MS1 set to 00) instead of Holdover mode. If the reference clock is available, the ZL30407 will transition briefly into Holdover to acquire synchronization and switch automatically to Normal mode. If the reference clock is not available at this time, as it may happen during new system installation, then the ZL30407 will stay in Holdover indefinitely. While in Holdover mode, the Core PLL will continue generating clocks with the same accuracy as in the Free-run mode, waiting for a good reference clock. When the system is connected to the network (or timing card switched to a valid reference) the Acquisition PLL will quickly synchronize and clear its own Holdover status (PAH bit). This will enable the Core PLL to start the synchronization process. After acquiring lock, the ZL30407 will automatically switch from Holdover into Normal mode without system intervention. This transition to the Normal mode will be flagged by the LOCK status bit and pin.

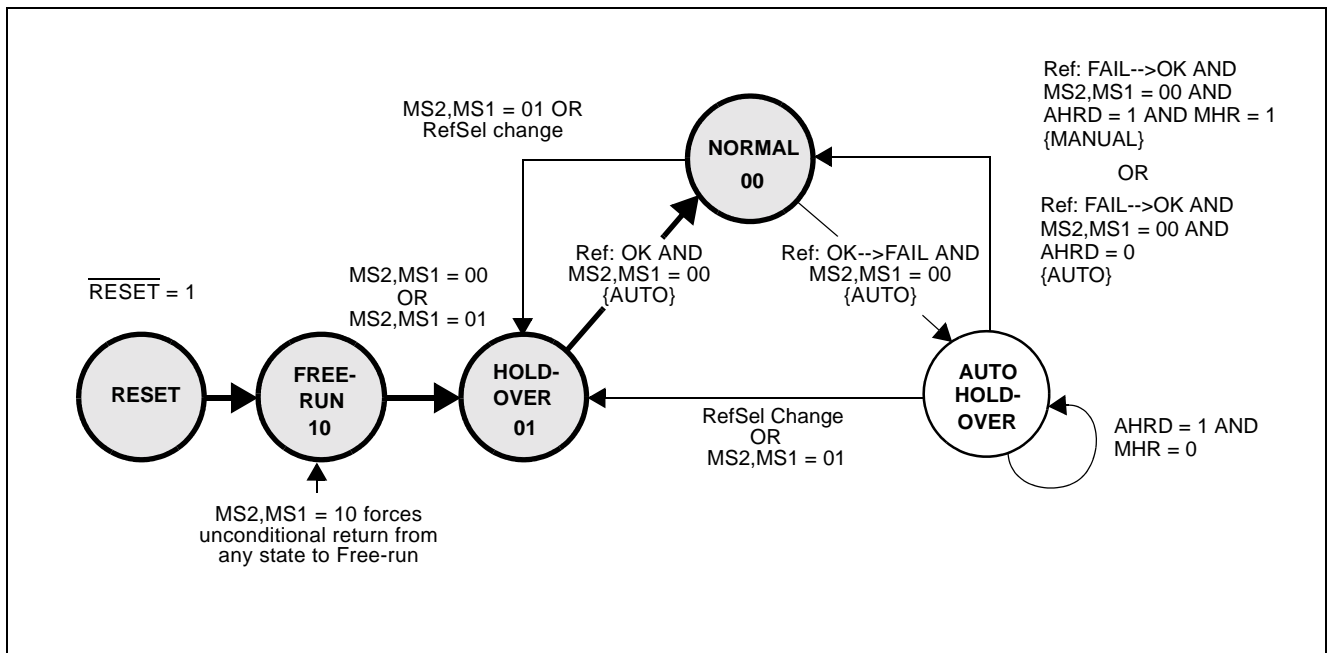

Figure 9 - Transition From Free-run to Normal Mode

4.1.2 Single Reference Operation: NORMAL --> AUTO HOLDOVER --> NORMAL

The NORMAL to AUTO-HOLDOVER to NORMAL transition will usually happen when the Network Element loses its single reference clock unexpectedly. The sequence starts with the reference clock transitioning from OK --> FAIL at a time when ZL30407 operates in Normal mode (as is shown in Figure 10). This failure is detected by the active Acquisition PLL based on the following FAIL criteria:

- Frequency offset on 8 kHz, 1.544 MHz, 2.048 MHz and 19.44 MHz reference clocks exceeds ± 30000 ppm ($\pm 3\%$).
- Single phase hit on 1.544 MHz, 2.048 MHz and 19.44 MHz exceeds half of the cycle of the reference clock

After detecting any of these anomalies on a reference clock the Acquisition PLL will switch itself into Holdover mode forcing the Core PLL to automatically switch into the Auto Holdover state. This condition is flagged by LOCK = 0 and HOLDOVER = 1.

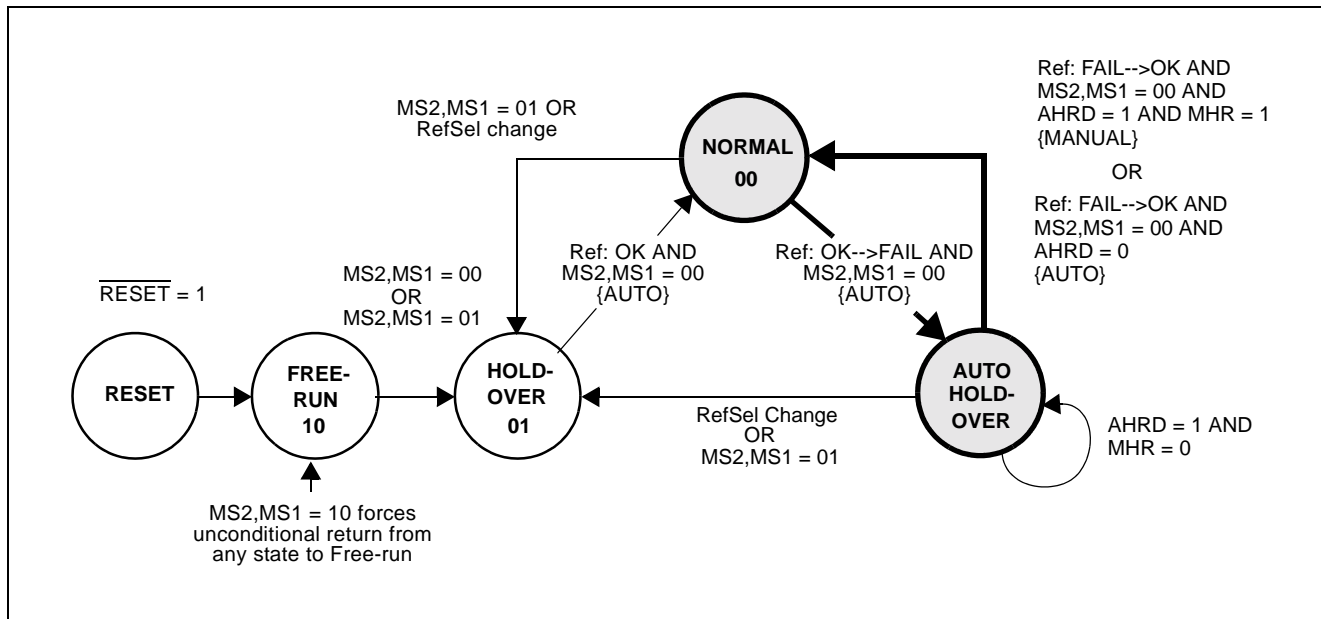

Figure 10 - Automatic Entry into Auto Holdover State and Recovery into Normal Mode

There are two possible returns to Normal mode after the reference signal is restored:

- With the AHRD (Automatic Holdover Return Disable) bit set to 0. In this case the Core PLL will automatically return to the Normal state after the reference signal recovers from failure. This transition is shown on the state diagram as a FAIL --> OK change. This change becomes effective when the reference is restored and there have been no phase hits detected for at least 64 clock cycles for the 1.544/2.048 MHz reference, 512 clock cycles for the 19.44 MHz reference and 1 clock cycle for the 8 kHz reference.
- With the AHRD bit set to 1 to disable automatic return to Normal and the change of MHR (Manual Holdover Release) bit from 0 to 1 to trigger the transition from Auto Holdover to Normal. This option is provided to protect the Core PLL and its stored holdover value against toggling between Normal and Auto Holdover states in case of an intermittent quality reference clock. In the case when MHR has been changed when the reference is still not available (Acquisition PLL in Holdover mode) the transition to Normal state will not occur and MHR 0 to 1 transition must be repeated.

The transition from Auto Holdover to Normal mode is performed as “hit-less” recovery for 1.544 MHz, 2.048 MHz and 19.44 MHz references. For the 8 kHz input reference, the recovery from Auto Holdover state must transition through the Holdover state to preserve “hit-less” recovery (for details see Section 4.1.3 on page 36).

4.1.3 Single 8 kHz Reference Operation: NORMAL --> AUTO HOLDOVER--> HOLDOVER --> NORMAL

The sequence starts from the Normal state and transitions to Auto Holdover state due to an unforeseen loss of the 8 kHz reference. The failure conditions triggering this transition are described in section 4.1.2. When in the Auto Holdover state, the ZL30410 can return to Normal mode automatically but this transition may exceed Output Phase Continuity limits specified in the table Performance Characteristics* on page 49. This probable time interval error is avoidable by forcing the PLL into Holdover state immediately after detection of the 8 kHz reference failure. While in Holdover state the ZL30410 will continue monitoring quality of the input reference (if a proper ± 4.6 ppm Master Clock oscillator is employed) and after detecting the presence of a valid reference it can be switched into Normal state. When the Master Clock Oscillator accuracy exceeds ± 4.6 ppm range (leading to inaccurate internal out-of-range detection) then an external method for detecting the presence of the clock should be employed to switch the ZL30410 into Normal state (0.1 sec after detecting the presence of a valid 8 kHz reference).

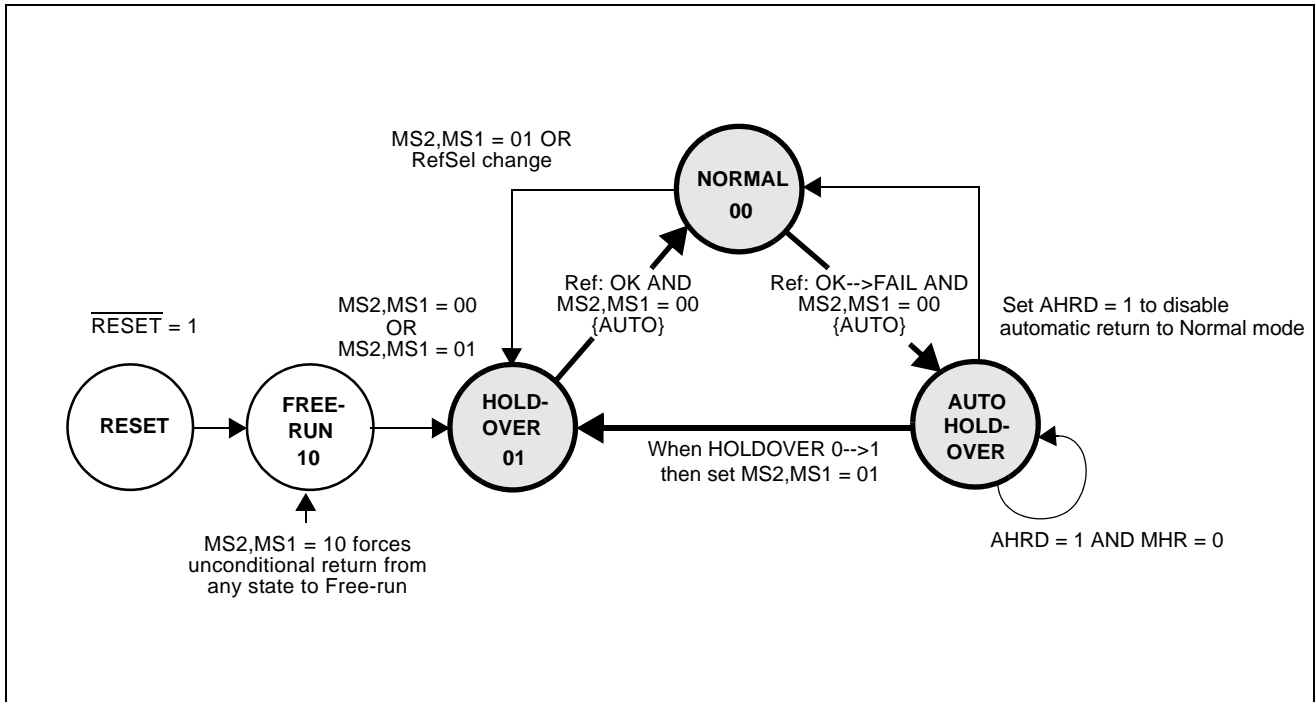

Figure 11 - Recovery Procedure From a Single 8 kHz Reference Failure by Transitioning Through the Holdover State

4.1.4 Dual Reference Operation: NORMAL --> AUTO HOLDOVER--> HOLDOVER --> NORMAL

The NORMAL to AUTO-HOLDOVER to HOLDOVER to NORMAL sequence represents the most likely operation of ZL30407 in Network Equipment.

The sequence starts from the Normal state and transitions to Auto Holdover state due to an unforeseen loss of reference. The failure conditions triggering this transition were described in section 4.1.2. When in the Auto Holdover state, the ZL30407 can return to Normal mode automatically if the lost reference is restored and the ADHR bit is set to 0. This transition from Auto Holdover to Normal mode is performed as “hit-less” recovery for 1.544 MHz, 2.048 MHz and 19.44 MHz references. For the 8 kHz input reference, the recovery from Auto Holdover state must transition through the Holdover state to preserve “hit-less” recovery (for details see Section 4.1.3 on page 36). If the reference clock failure persists for a period of time that exceeds the system design limit, the system control processor may initiate a reference switch. If the secondary reference is available the ZL30407 will briefly switch into Holdover mode and then transition to Normal mode.

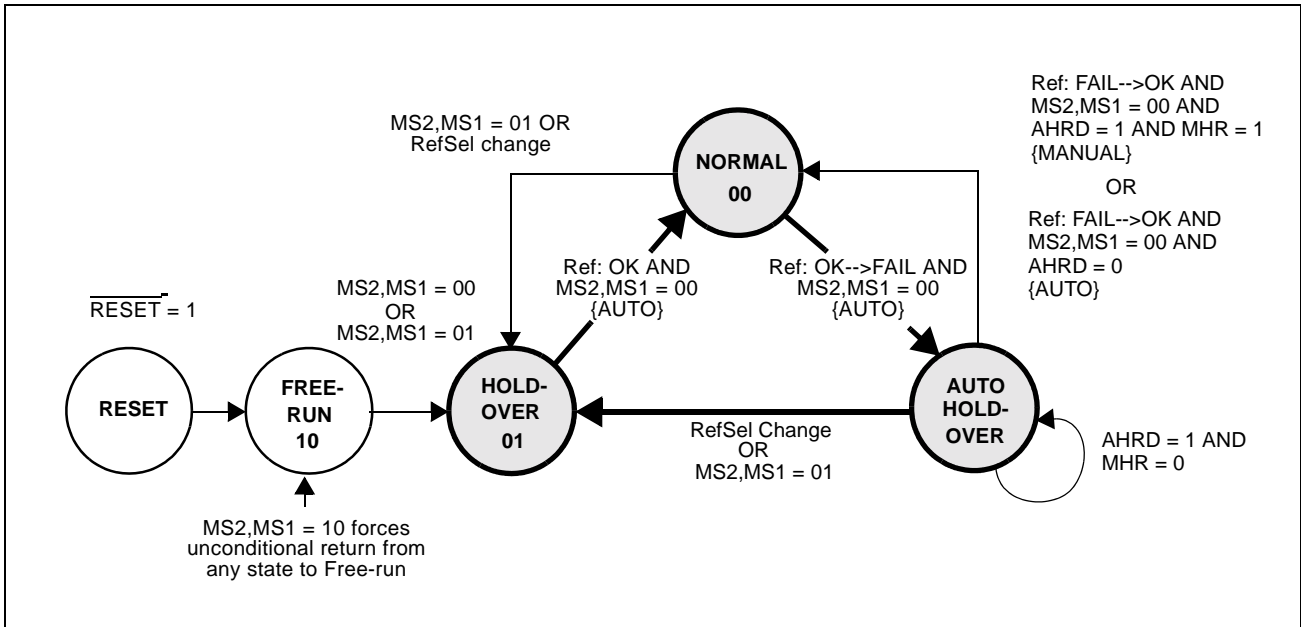

Figure 12 - Entry into Auto Holdover State and Recovery into Normal Mode by Switching References

The new reference clock will most likely have a different phase but it may also have a different fractional frequency offset. In order to lock to a new reference with a different frequency, the Core PLL may be stepped gradually towards the new frequency.

4.1.5 Reference Switching (RefSel): NORMAL --> HOLDOVER --> NORMAL

The NORMAL to HOLDOVER to NORMAL mode switching is usually performed when:

- A reference clock is available but its frequency drifts beyond some specified limit. In a Network Element with stratum 3 internal clocks, the reference failure is declared when its frequency drifts more than ± 12 ppm beyond its nominal frequency. The ZL30407 indicates this condition by setting PRIOR or SECOR status bits or pins to logic high.
- During routine maintenance of equipment when orderly switching of reference clocks is possible. This may happen when synchronization references must be rearranged or when a faulty line card must be replaced.

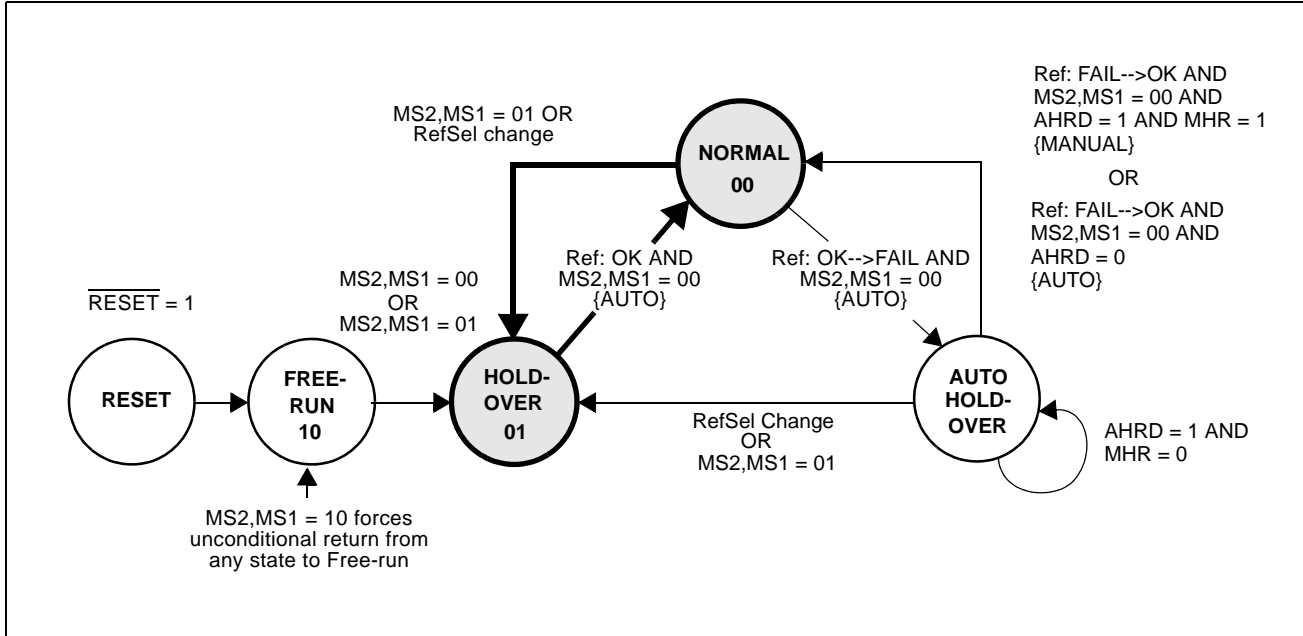

Figure 13 - Manual Reference Switching

Two types of transitions are possible:

- Semi-automatic transition, which involves changing RefSel input to select a secondary reference clock without changing the mode select inputs MS2, MS1 = 00 (Normal mode). This forces the ZL30407 to momentarily transition through the Holdover state and automatically return to Normal mode after synchronizing to a secondary reference clock.
- Manual transition, which involves switching into Holdover mode (MS2,MS1 = 01), changing references with RefSel, and manual return to the Normal mode (MS2, MS1 = 00).

In both cases, the change of references provides "hitless" switching.

4.2 Master/Slave Timing Protection Switching

Carrier Class Telecommunications Equipment deployed in today's networks guarantee better than 99.999% operational availability (equivalent to less than 7 minutes of downtime per year). This high level of uninterrupted service is achieved by fully redundant architectures with hot swappable cards. Timing for these types of systems can be generated by the ZL30407 which supports Master/Slave Timing Protection Switching shown in Figure 14.

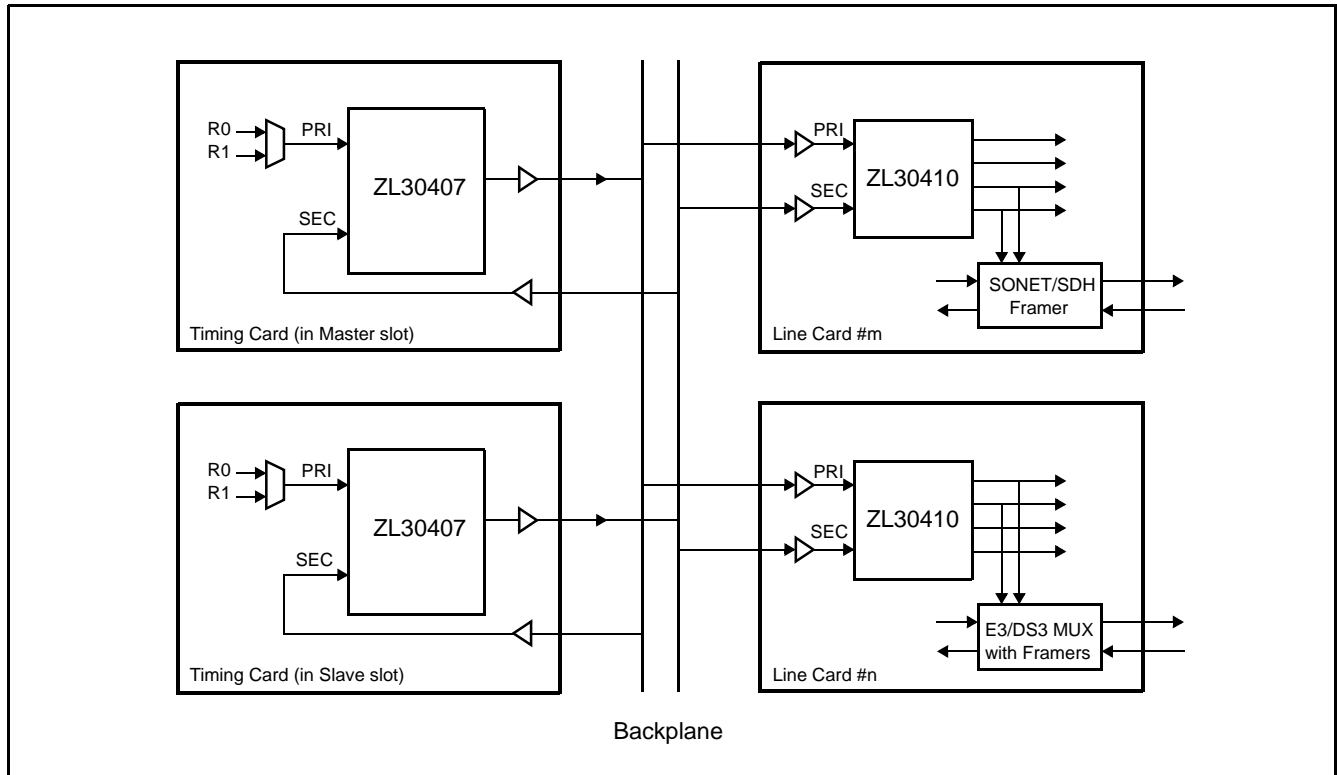

Figure 14 - Block Diagram of the Master/Slave Timing Protection Switching

The redundant architecture shown in this figure is based on the ZL30407 being deployed on two separate timing cards; the Master Timing Card and the Slave Timing Card. In normal operation the Master Timing Card receives synchronization from the network and provides timing for the whole system. All Line Cards in the system are configured to receive from the backplane a reference clock generated by the Master Timing Card. The redundant Slave Timing Card is phase locked (through the R3 input) to one of the backplane clocks supplied by the Master Timing Card. The ZL30407 on the Slave Timing Card is programmed for 12 Hz loop filter operation (FCS2 = 1, FCS = 0) which allows it to track the Master Timing Card clocks with minimal phase error.

When the Master Timing card fails unexpectedly (this failure is not related to reference failure) then all Line Cards will detect this failure and they will switch to the timing supplied by the Slave Timing Card. At this moment the ZL30407 on the Slave Timing Card must be switched from 12 Hz to the same loop filter characteristic (e.g. 1.5 Hz filter for SDH networks) as the Master Timing Card.

A detailed description of this Master/Slave redundant timing architecture based on ZL30407 can be found in Application Note ZLAN-67 "Applications of the ZL30407 Master/Slave Application".

4.3 Programming Master Clock Oscillator Frequency Calibration Register

The Master Crystal Oscillator and its programmable Master Clock Frequency Calibration register (see Table 19, Table 20, Table 21, and Table 22) are described in Section 2.5 "Master Clock Frequency Calibration Circuit", on page 20. Programming of this register should be done after the system has been powered long enough for the Master Crystal Oscillator to reach a steady operating temperature. When the temperature stabilizes the crystal oscillator frequency should be measured with an accurate frequency meter. The frequency measurement should be substituted for the f_{offset} variable in the following equation.

$$MCFC = 45036 * (-f_{offset})$$

where f_{offset} is the crystal oscillator frequency offset from the nominal 20 000 000 Hz frequency expressed in Hz.

Example 1: Calculate the binary value that must be written to the MCFC register to correct a -1 ppm offset of the Master Crystal Oscillator. The -1 ppm offset for a 20 MHz frequency is equivalent to -20 Hz:

$$MCFC = 45036 * 20 = 900720 = 00\ 0D\ BE\ 70\ H$$

Note: Correcting the -1 ppm crystal oscillator offset requires +1 ppm MCFC offset.

Example 2: Calculate the binary value that must be written to the MCFC register to correct a +2 ppm offset of the Master Crystal Oscillator. The +2 ppm offset for 20 MHz frequency is equivalent to 40 Hz:

$$MCFC = 45036 * (-40) = -1801440 = FF\ E4\ 83\ 20\ H$$

4.4 Power supply filtering

Figure 15 "Power Supply Filtering" presents a complete filtering arrangement that is recommended for applications requiring maximum jitter performance.

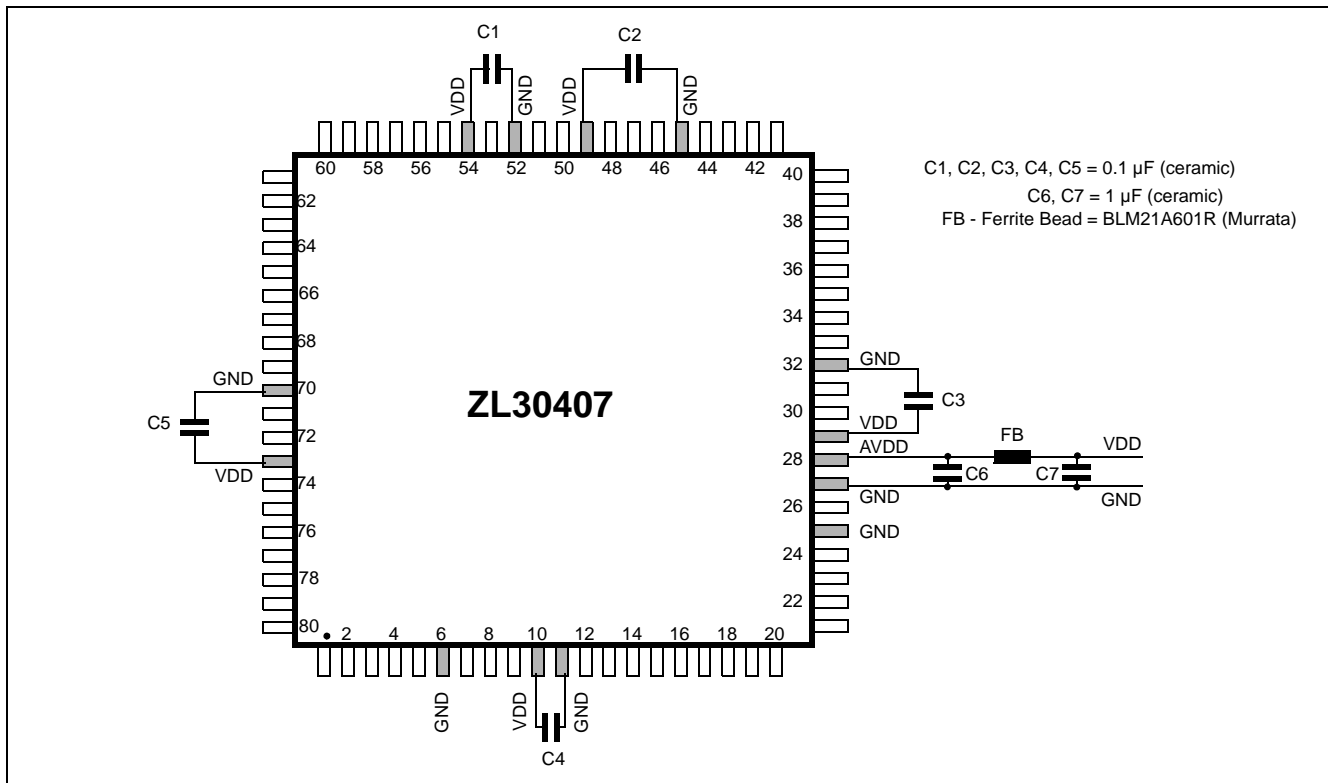

Figure 15 - Power Supply Filtering

5.0 Characteristics

5.1 AC and DC Electrical Characteristics

Absolute Maximum Ratings*

	Parameter	Symbol	Min.	Max.	Units
1	Supply voltage	V_{DDR}	-0.3	7.0	V
2	Voltage on any pin	V_{PIN}	-0.3	$V_{DD}+0.3$	V
3	Current on any pin	I_{PIN}		30	mA
4	Storage temperature	T_{ST}	-55	125	°C
5	Package power dissipation (80 pin LQFP)	P_{PD}		1000	mW
6	ESD rating	V_{ESD}		1500	V

* Voltages are with respect to ground (GND) unless otherwise stated.

* Exceeding these values may cause permanent damage. Functional operation under these conditions is not implied.

Recommended Operating Conditions*

	Characteristics	Symbol	Min.	Typ.	Max.	Units
1	Supply voltage	V_{DD}	3.0	3.3	3.6	V
2	Operating temperature	T_A	-40	25	+85	°C

* Voltages are with respect to ground (GND) unless otherwise stated.

DC Electrical Characteristics*

	Characteristics	Symbol	Min.	Max.	Units	Notes
1	Supply current with $C_{20i} = 20$ MHz	I_{DD}		155	mA	Outputs unloaded
2	Supply current with $C_{20i} = 0$ V	I_{DDS}		3.5	mA	Outputs unloaded
3	CMOS high-level input voltage	V_{CIH}	$0.7 V_{DD}$		V	
4	CMOS low-level input voltage	V_{CIL}		$0.3 V_{DD}$	V	
5	Input leakage current	I_{IL}		15	μA	$V_I = V_{DD}$ or GND
6	High-level output voltage	V_{OH}	2.4		V	$I_{OH} = 10$ mA
7	Low-level output voltage	V_{OL}		0.4	V	$I_{OL} = 10$ mA
8	LVDS: Differential output voltage	V_{OD}	250	450	mV	$Z_T = 100 \Omega$
9	LVDS: Change in V_{OD} between complementary output states	dV_{OD}		50	mV	$Z_T = 100 \Omega$
10	LVDS: Offset voltage	V_{OS}	1.125	1.375	V	Note 1
11	LVDS: Change in V_{OS} between complementary output states	dV_{OS}		50	mV	
12	LVDS: Output short circuit current	I_{OS}		24	mA	Pin short to GND
13	LVDS: Output rise and fall times	T_{RF}	260	900	ps	Note 2

* Voltages are with respect to ground (GND) unless otherwise stated.

Note 1: V_{OS} is defined as $(V_{OH} + V_{OL}) / 2$.

Note 2: Rise and fall times are measured at 20% and 80% levels.

AC Electrical Characteristics - Timing Parameter Measurement - CMOS Voltage Levels*

	Characteristics	Symbol	Level	Units
1	Threshold voltage	V_T	$0.5 V_{DD}$	V
2	Rise and fall threshold voltage High	V_{HM}	$0.7 V_{DD}$	V
3	Rise and fall threshold voltage Low	V_{LM}	$0.3 V_{DD}$	V

* Voltages are with respect to ground (GND) unless otherwise stated.

* Supply voltage and operating temperature are as per Recommended Operating Conditions.

* Timing for input and output signals is based on the worst case conditions (over T_A and V_{DD}).

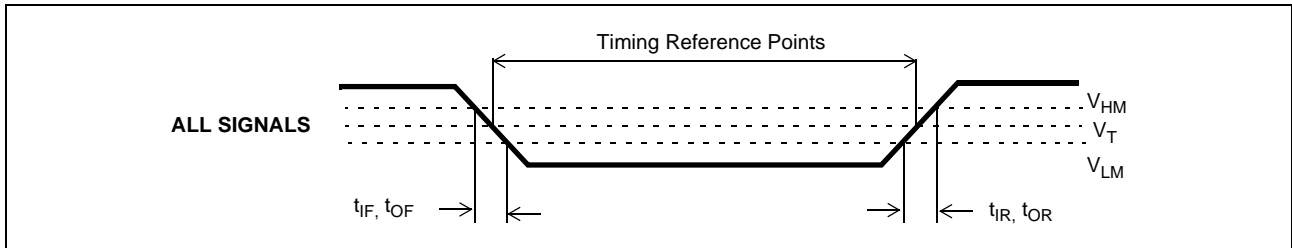

Figure 16 - Timing Parameters Measurement Voltage Levels

AC Electrical Characteristics - Microprocessor Timing*

	Characteristics	Symbol	Min.	Max.	Units	Notes
1	DS Low	t_{DSL}	65		ns	
2	DS High	t_{DSH}	100		ns	
3	CS Setup	t_{CSS}	0		ns	
4	CS-Hold	t_{CSH}	0		ns	
5	R/W Setup	t_{RWS}	20		ns	
6	R/W Hold	t_{RWH}	5		ns	
7	Address Setup	t_{ADS}	10		ns	
8	Address Hold	t_{ADH}	10		ns	
9	Data Read Delay	t_{DRD}		60	ns	$C_L = 90 \text{ pF}$
10	Data Read Hold	t_{DRH}		10	ns	
11	Data Write Setup	t_{DWS}	10		ns	
12	Data Write Hold	t_{DWH}	5		ns	

* Supply voltage and operating temperature are as per Recommended Operating Conditions.

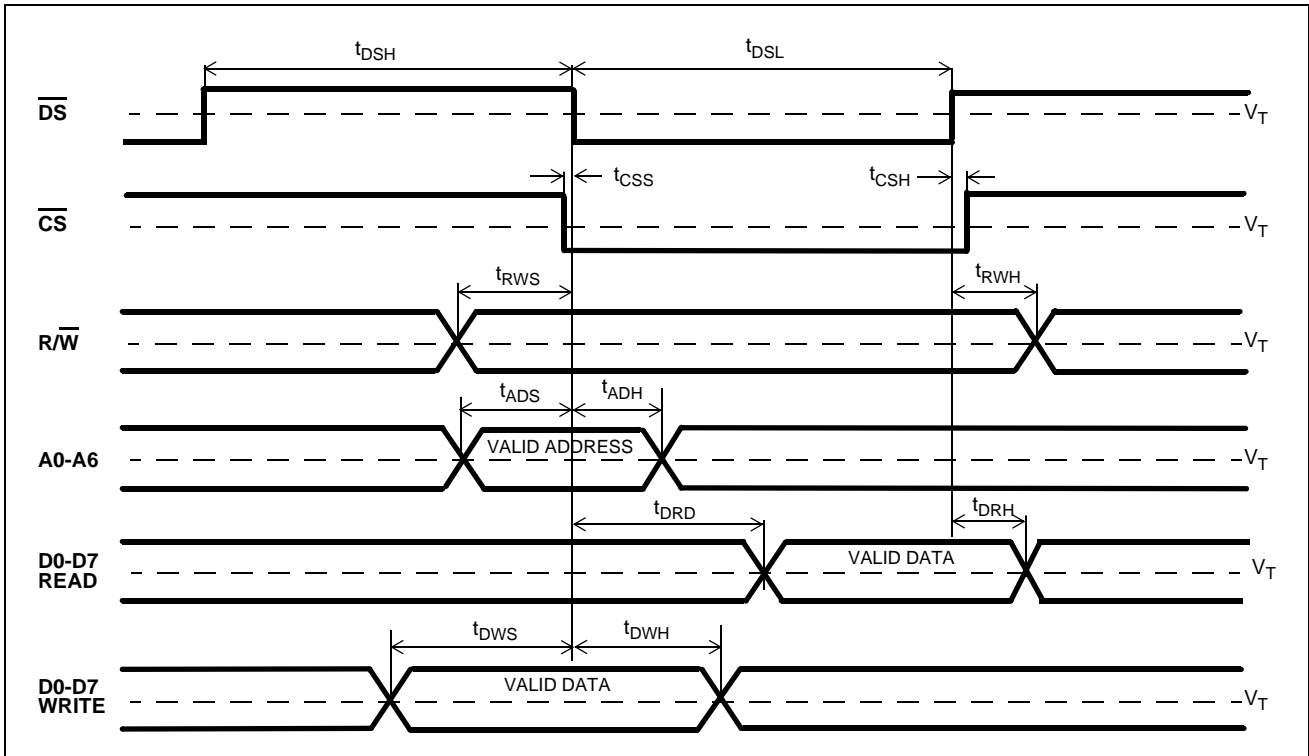

Figure 17 - Microport Timing

AC Electrical Characteristics - ST-BUS and GCI Output Timing*

	Characteristics	Symbol	Min.	Max.	Units	Notes
1	$\overline{F16o}$ pulse width low (nom 61 ns)	t_{F16L}	56	62	ns	
2	F8o to $\overline{F16o}$ delay	t_{F16D}	27	33	ns	
3	$\overline{C16o}$ pulse width low	t_{C16L}	26	32	ns	
4	F8o to $\overline{C16o}$ delay	t_{C16D}	-3	3	ns	
5	F8o pulse width high (nom 122 ns)	t_{F8H}	119	125	ns	
6	C8o pulse width low	t_{C8L}	56	62	ns	
7	F8o to C8o delay	t_{C8D}	-3	3	ns	
8	$\overline{F0o}$ pulse width low (nom 244 ns)	t_{F0L}	241	247	ns	
9	F8o to $\overline{F0o}$ delay	t_{F0D}	119	125	ns	
10	$\overline{C4o}$ pulse width low	t_{C4L}	119	125	ns	
11	F8o to $\overline{C4o}$ delay	t_{C4D}	-3	3	ns	
12	C2o pulse width low	t_{C2L}	240	246	ns	
13	F8o to C2o delay	t_{C2D}	-3	3	ns	

* Supply voltage and operating temperature are as per Recommended Operating Conditions.

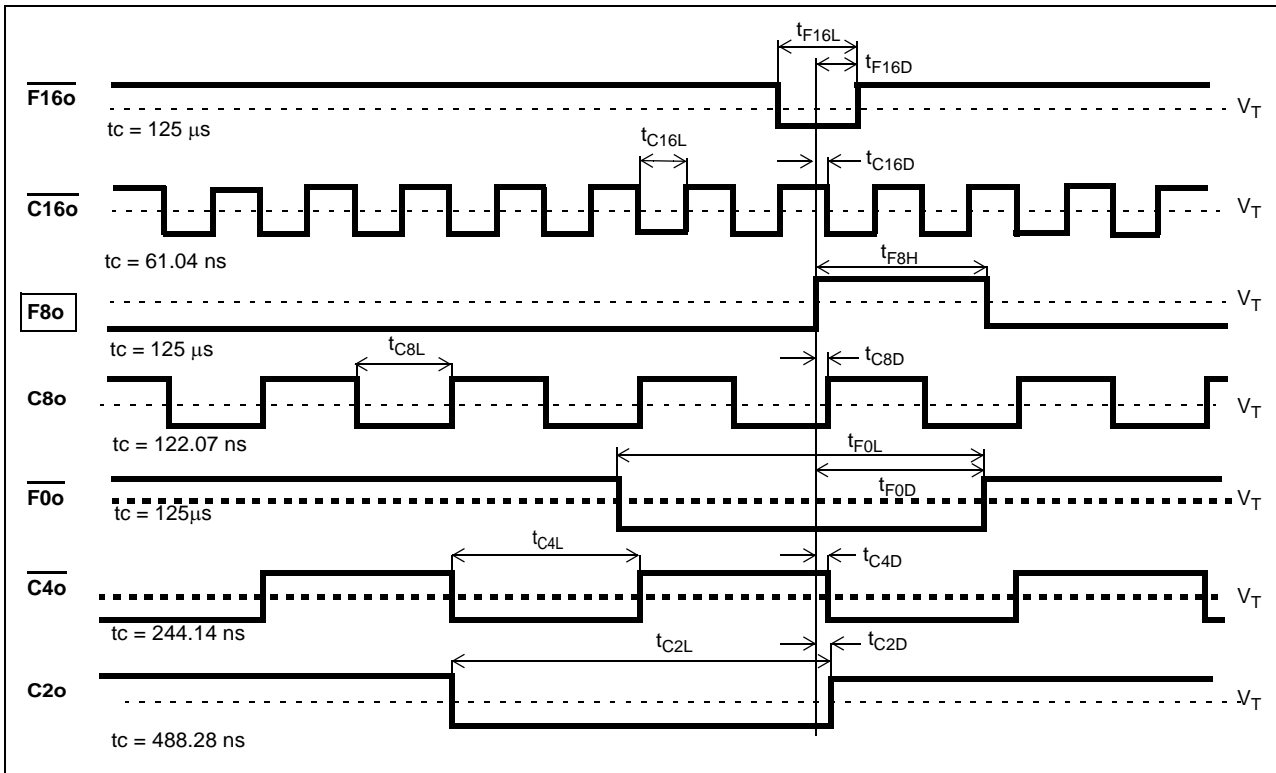

Figure 18 - ST-BUS and GCI Output Timing

AC Electrical Characteristics - DS1 and DS2 Clock Timing*

	Characteristics	Symbol	Min.	Max.	Units	Notes
1	C6o pulse width low	t_{C6L}	75	83	ns	
2	F8o to C6o delay	t_{C6D}	-4	11	ns	
3	C1.5o pulse width low	$t_{C1.5L}$	320	328	ns	
4	F8o to C1.5o delay	$t_{C1.5D}$	-4	11	ns	

* Supply voltage and operating temperature are as per Recommended Operating Conditions.

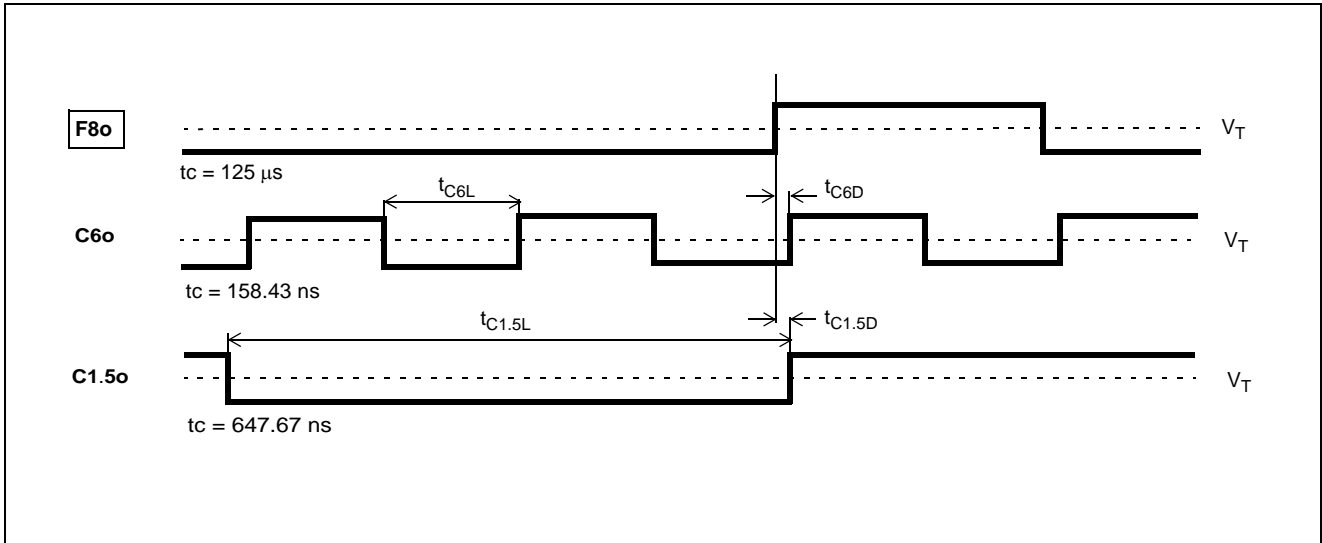

Figure 19 - DS1 and DS2 Clock Timing

AC Electrical Characteristics - C155o and C19o Clock Timing

	Characteristics	Symbol	Min.	Max.	Units	Notes
1	C155o pulse width low	t_{C155L}	2.6	3.8	ns	
2	C155o to C19o rising edge delay	t_{C19DLH}	-1	7	ns	
3	C155o to C19o falling edge delay	t_{C19DHL}	-2	6	ns	
4	C19 pulse width high	t_{C19H}	23	29		

* Supply voltage and operating temperature are as per Recommended Operating Conditions.

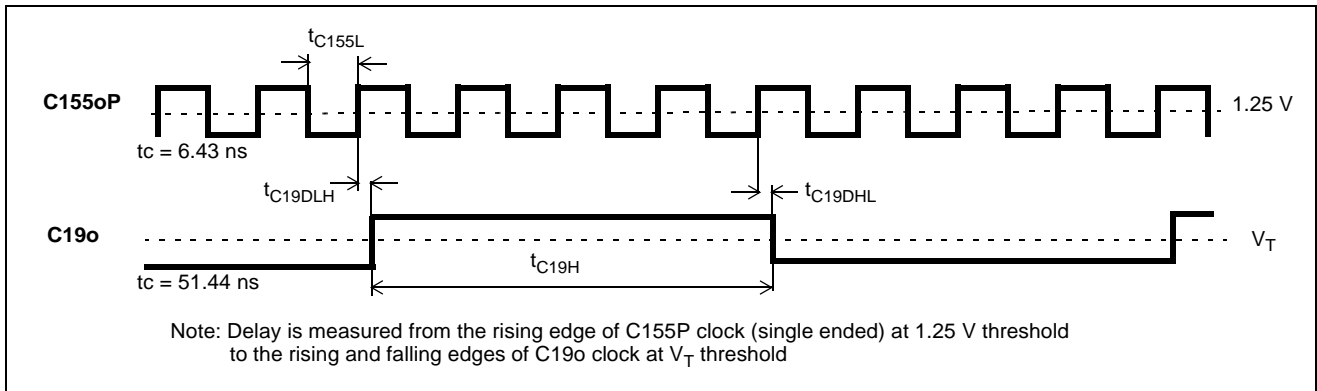

Figure 20 - C155o and C19o Timing

AC Electrical Characteristics - Input to Output Phase Offset (after phase realignment)*

	Characteristics	Symbol	Min.	Max.	Units	Notes
1	8 kHz ref: pulse width high or low	t_{R8W}	100		ns	
2	8 kHz ref input to F8o delay	t_{R8D}	-6	29	ns	
3	1.544 MHz ref: pulse width high or low	$t_{R1.5W}$	100		ns	
4	1.544 MHz ref input to F8o delay	$t_{R1.5D}$	335	350	ns	
5	2.048 MHz ref: pulse width high or low	t_{R2W}	100		ns	
6	2.048 MHz ref input to F8o delay	t_{R2D}	255	272	ns	
7	19.44 MHz ref: pulse width high or low	t_{R19W}	20		ns	
8	19.44 MHz ref input to F8o delay	t_{R19D}	8	21	ns	
9	F8o to C19o delay	t_{C19D}	-5	7	ns	
10	Reference input rise and fall time	t_{IR}, t_{IF}		10	ns	

* Supply voltage and operating temperature are as per Recommended Operating Conditions.

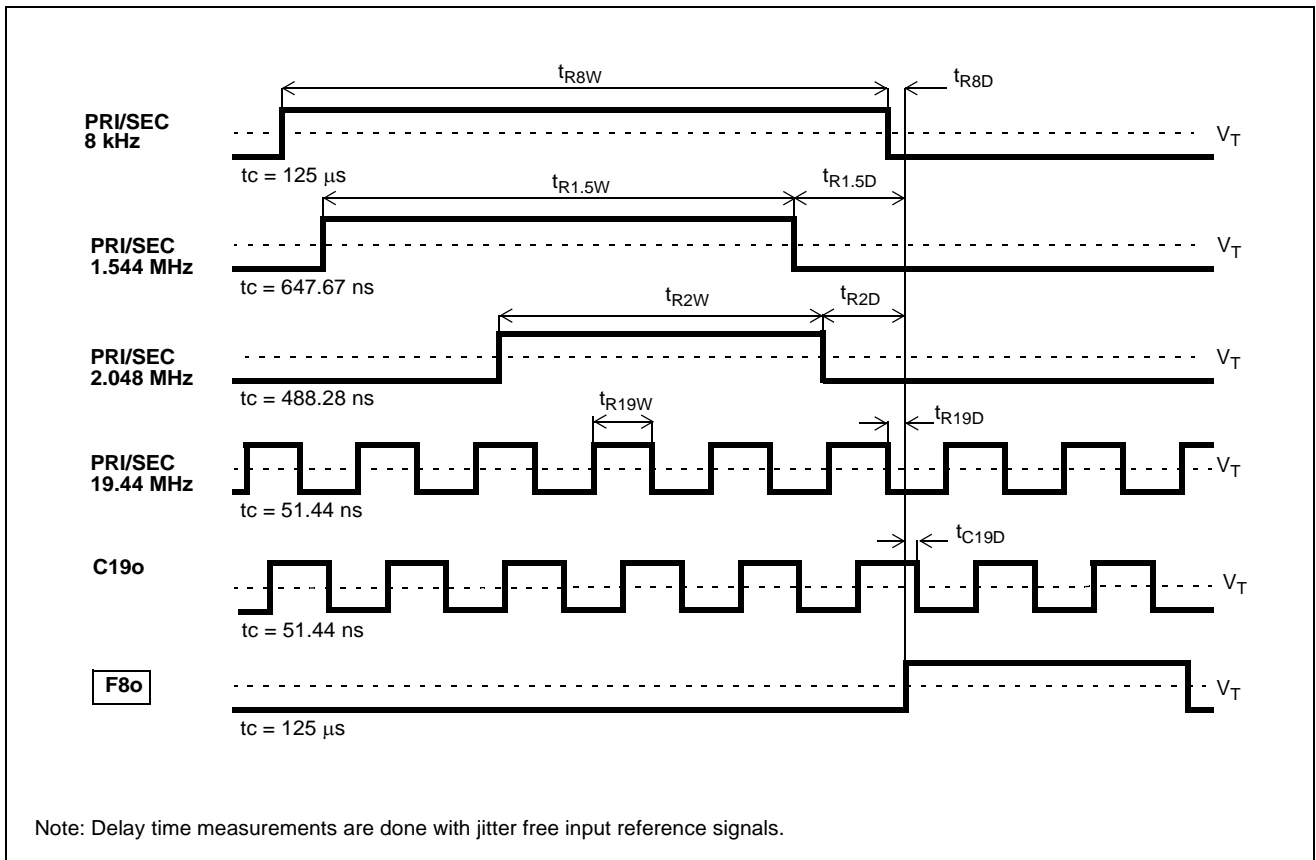

Figure 21 - Input Reference to Output Clock Phase Offset

AC Electrical Characteristics - Input Control Signals*

	Characteristics	Symbol	Min.	Max.	Units	Notes
1	Input controls Setup time	t_S	100		ns	
2	Input controls Hold time	t_H	100		ns	

* Supply voltage and operating temperature are as per Recommended Operating Conditions

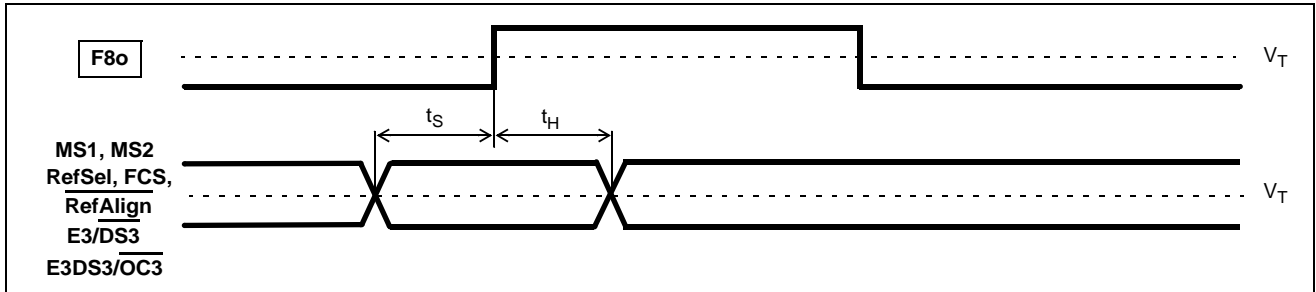

Figure 22 - Input Control Signal Setup and Hold Time

AC Electrical Characteristics - E3 and DS3 Output Timing*

	Characteristics	Symbol	Min.	Max.	Units	Notes
1	C44o clock pulse width high	t_{C44H}	11	13	ns	
2	C11o clock pulse width high	t_{C11H}	5	26	ns	
3	C34o clock pulse width high	t_{C34H}	13	16	ns	
4	C8.5o clock pulse width high	$t_{C8.5H}$	9	24	ns	

* Supply voltage and operating temperature are as per Recommended Operating Conditions.

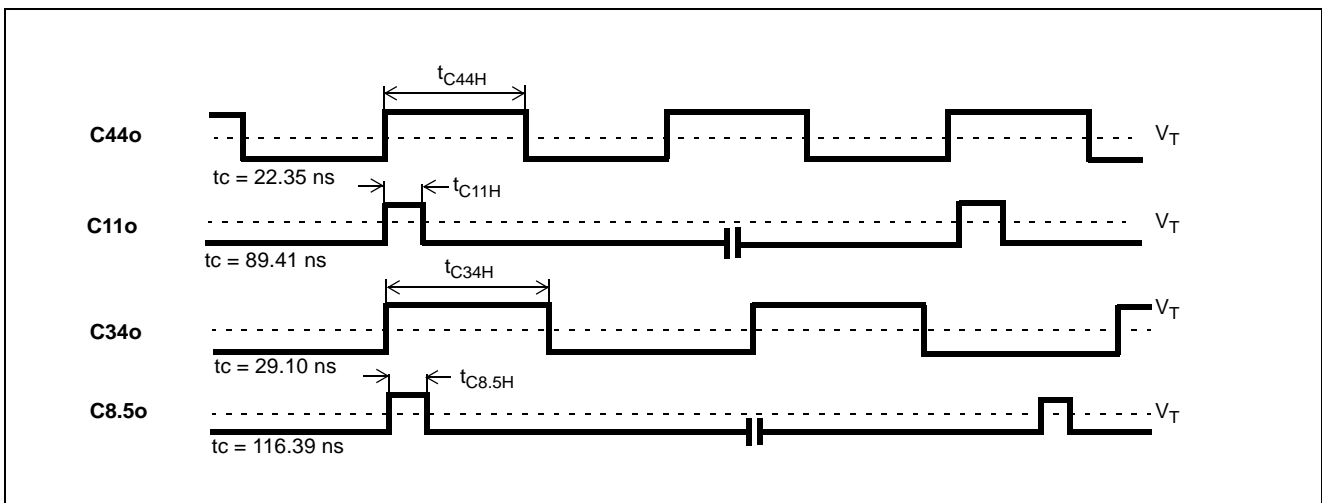

Figure 23 - E3 and DS3 Output Timing

5.2 Performance Characteristics

Performance Characteristics*

	Characteristics	Min.	Typ.	Max.	Units	Notes
1	Holdover accuracy		4×10^{-12}	7×10^{-12}	Hz/Hz	0.1 Hz Filter
2	Holdover accuracy		24×10^{-12}	32×10^{-12}	Hz/Hz	1.5 Hz Filter
3	Holdover accuracy		70×10^{-12}	160×10^{-12}	Hz/Hz	6 Hz Filter
4	Holdover accuracy		140×10^{-12}	320×10^{-12}	Hz/Hz	12 Hz Filter
5	Holdover stability			NA	ppm	Holdover stability is determined by stability of the 20 MHz Master Clock oscillator
6	Capture range	-104		+104	ppm	The 20 MHz Master Clock oscillator set at 0ppm
7	Reference Out of Range Threshold	-12		+12	ppm	The 20 MHz Master Clock oscillator set at 0 ppm
Lock Time						
8	6 Hz or 12 Hz Filter			6	s	± 4.6 ppm frequency offset
9	6 Hz or 12 Hz Filter			6	s	± 20 ppm frequency offset
10	1.5 Hz Filter			20	s	± 4.6 ppm frequency offset
11	0.1 Hz Filter			75	s	± 4.6 ppm frequency offset
12	0.1 Hz Filter			95	s	± 20 ppm frequency offset
Output Phase Continuity (MTIE)						
13	Reference switching: PRI \Rightarrow SEC, SEC \Rightarrow PRI			50	ns	PRI = SEC = 8 kHz
				5	ns	PRI or SEC = 1.544 MHz, 2.048 MHz, 19.44 MHz
14	Switching from Normal mode to Holdover mode			0	ns	
15	Switching from Holdover mode to Normal mode			50	ns	PRI = SEC = 8 kHz
				2	ns	PRI or SEC = 1.544 MHz, 2.048 MHz, 19.44 MHz (for 0 ppm frequency offset)
Output Phase Slope						
16	0.1 Hz Filter		885		$\frac{\text{ns}}{\text{sec}}$	G.813 Option 2 GR-253 SONET stratum 3 GR-253 SONET SMC
17	1.5 Hz Filter		41		$\frac{\text{ns}}{1.326 \text{ ms}}$	G.813 Option 1, GR-1244 stratum 3

Performance Characteristics* (continued)

	Characteristics	Min.	Typ.	Max.	Units	Notes
18	6 Hz Filter		41		$\frac{\text{ns}}{1.326 \text{ ms}}$	G.813 Option 1
19	12 Hz Filter		150		$\frac{\mu\text{s}}{\text{sec}}$	

* Supply voltage and operating temperature are as per Recommended Operating Conditions.
 Note: See Section 2.2.3 for an explanation of Phase Slope Limiting.

Performance Characteristics : Measured Output Jitter - GR-253-CORE and T1.105.03 conformance

Telcordia GR-253-CORE and ANSI T1.105.03 Jitter Generation Requirements					ZL30407 Jitter Generation Performance		
	Network Interface	Jitter Measurement Filter	Limit in UI	Equivalent limit in time domain	Typ.	Units	Notes
					C155 Clock Output		
1	OC-3 155.52 Mbps	65 kHz to 1.3 MHz	0.15 UIpp	0.964	0.325	nSp-p	
2		12 kHz to 1.3 MHz (Category II)	0.1 UIpp	0.643	0.408	nSp-p	
			0.01 UI _{RMS}	0.064	0.038	nSRMS	
3		500 Hz to 1.3 MHz	1.5 UIpp	9.645	0.448	nSp-p	
					C19 Clock Output		
4	OC-3 155.52 Mbps	65 kHz to 1.3 MHz	0.15 UIpp	0.964	0.390	nSp-p	
5		12 kHz to 1.3 MHz (Category II)	0.1 UIpp	0.643	0.458	nSp-p	
			0.01 UI _{RMS}	0.064	0.040	nSRMS	
6		500 Hz to 1.3 MHz	1.5 UIpp	9.645	0.512	nSp-p	

* Supply voltage and operating temperature are as per Recommended Operating Conditions.

Performance Characteristics : Measured Output Jitter - T1.403 conformance

ANSI T1.403 Jitter Generation Requirements					ZL30407 Jitter Generation Performance		
	Network Interface	Jitter Measurement Filter	Limit in UI	Equivalent limit in time domain	Typ.	Units	Notes
					C1.5 Clock Output		
1	DS1 1.544 Mbps	8 kHz to 40 kHz	0.07 UIpp	45.3	0.63	nSp-p	
2		10 Hz to 40 kHz	0.5 UIpp	324	0.93	nSp-p	

* Supply voltage and operating temperature are as per Recommended Operating Conditions.

Performance Characteristics : Measured Output Jitter - G.747 conformance

ITU-T G.747 Jitter Generation Requirements					ZL30407 Jitter Generation Performance		
	Network Interface	Jitter Measurement Filter	Limit in UI	Equivalent limit in time domain	Typ.	Units	Notes
					C6 Clock Output		
1	DS2 6312 kbps	10 Hz to 60 kHz	0.05 UIpp	7.92	0.53	nSp.p	

* Supply voltage and operating temperature are as per Recommended Operating Conditions.

Performance Characteristics : Measured Output Jitter - T1.404 conformance

ANSI T1.403 Jitter Generation Requirements					ZL30407 Jitter Generation Performance		
	Network Interface Type I	Jitter Measurement Filter	Limit in UI	Equivalent limit in time domain	Typ.	Units	Notes
					C44 Clock Output		
1	DS3 44.736 Mbps	30 kHz to 400 kHz	0.05 UIpp	1.12	0.30	nSp.p	
2		10 Hz to 400 kHz	0.5 UIpp	11.2	0.47	nSp.p	

* Supply voltage and operating temperature are as per Recommended Operating Conditions.

Performance Characteristics : Measured Output Jitter - G.732, G.735 to G.739 conformance

ITU-T G.732, G.735, G.736, G.737, G.738, G.739 Jitter Generation Requirements					ZL30407 Jitter Generation Performance		
	Network Interface	Jitter Measurement Filter	Limit in UI	Equivalent limit in time domain	Typ.	Units	Notes
					C16, C8, C4 and C2 Clock Outputs		
1	E1 2048 kbps	20 Hz to 100 kHz	0.05 UIpp	24.4	0.56	nSp.p	

* Supply voltage and operating temperature are as per Recommended Operating Conditions.

Performance Characteristics : Measured Output Jitter - G.751 conformance

ITU-T G.751 Jitter Generation Requirements					ZL30407 Jitter Generation Performance		
	Network Interface	Jitter Measurement Filter	Limit in UI	Equivalent limit in time domain	Typ.	Units	Notes
					C34 Clock Output		
1	E3 34368 kbps	100 Hz to 800 kHz	0.05 Ulpp	1.45	0.64	nSp-p	

* Supply voltage and operating temperature are as per Recommended Operating Conditions.

Performance Characteristics : Measured Output Jitter - G.812 conformance

ITU-T G.812 Jitter Generation Requirements					ZL30407 Jitter Generation Performance		
	Network Interface	Jitter Measurement Filter	Limit in UI	Equivalent limit in time domain	Typ.	Units	Notes
					C155 Clock Output		
1	STM-1 optical 155.52 Mbps	65 kHz to 1.3 MHz	0.1 Ulpp	0.643	0.325	nSp-p	
2		500 Hz to 1.3 MHz	0.5 Ulpp	3.215	0.448	nSp-p	
					C155 Clock Output		
3	STM-1 electrical 155.52 Mbps	65 kHz to 1.3 MHz	0.075 Ulpp	0.482	0.325	nSp-p	
4		500 Hz to 1.3 MHz	0.5 Ulpp	3.215	0.448	nSp-p	
					C19 Clock Output		
5	STM-1 optical 155.52 Mbps	65 kHz to 1.3 MHz	0.1 Ulpp	0.643	0.390	nSp-p	
6		500 Hz to 1.3 MHz	0.5 Ulpp	3.215	0.512	nSp-p	
					C19 Clock Output		
7	STM-1 electrical 155.52 Mbps	65 kHz to 1.3 MHz	0.075 Ulpp	0.482	0.390	nSp-p	
8		500 Hz to 1.3 MHz	0.5 Ulpp	3.215	0.512	nSp-p	
					C16, C8, C4 and C2 Clock Outputs		
9	E1 2048 kbps	20 Hz to 100 kHz	0.05 Ulpp	24.4	0.56	nSp-p	
					C1.5 Clock Output		
10	DS1 1.544 Mbps	10 Hz to 40 kHz	0.05 Ulpp	32.4	0.93	nSp-p	

* Supply voltage and operating temperature are as per Recommended Operating Conditions.

Performance Characteristics : Measured Output Jitter - G.813 conformance (Option 1 and Option 2)

ITU-T G.813 Jitter Generation Requirements					ZL30407 Jitter Generation Performance		
	Interface	Jitter Measurement Filter	Limit in UI	Equivalent limit in time domain	Typ.	Units	Notes
Option 1					C155 Clock Output		
1	STM-1 155.52 Mbps	65 kHz to 1.3 MHz	0.1 Ulpp	0.643	0.325	n _{Sp,p}	
2		500 Hz to 1.3 MHz	0.5 Ulpp	3.215	0.448	n _{Sp,p}	
					C19 Clock Output		
3	STM-1 155.52 Mbps	65 kHz to 1.3 MHz	0.1 Ulpp	0.643	0.390	n _{Sp,p}	
4		500 Hz to 1.3 MHz	0.5 Ulpp	3.215	0.512	n _{Sp,p}	
					C16, C8, C4 and C2 Clock Outputs		
5	E1 2048 kbps	20 Hz to 100 kHz	0.05 Ulpp	24.4	0.56	n _{Sp,p}	
Option 2					C155 Clock Output		
6	STM-1 155.52 Mbps	12 kHz to 1.3 MHz	0.1 Ulpp	0.643	0.408	n _{Sp,p}	
					C19 Clock Output		
7	STM-1 155.52 Mbps	12 kHz to 1.3 MHz	0.1 Ulpp	0.643	0.458	n _{Sp,p}	

* Supply voltage and operating temperature are as per Recommended Operating Conditions.

Performance Characteristics : Measured Output Jitter - EN 300 462-7-1 conformance

ETSI EN 300 462-7-1 Jitter Generation Requirements					ZL30407 Jitter Generation Performance		
	Interface	Jitter Measurement Filter	Limit in UI	Equivalent limit in time domain	Typ.	Units	Notes
					C155 Clock Output		
1	STM-1 optical 155.52 Mbps	65k Hz to 1.3 MHz	0.1 Ulpp	0.643	0.325	nSp.p	
2		500 Hz to 1.3 MHz	0.5 Ulpp	3.215	0.448	nSp.p	
					C155 Clock Output		
3	STM-1 electrical 155.52 Mbps	65 kHz to 1.3 MHz	0.075 Ulpp	0.482	0.325	nSp.p	
4		500 Hz to 1.3 MHz	0.5 Ulpp	3.215	0.448	nSp.p	
					C19 Clock Output		
5	STM-1 optical 155.52 Mbps	65 kHz to 1.3 MHz	0.1 Ulpp	0.643	0.390	nSp.p	
6		500 Hz to 1.3 MHz	0.5 Ulpp	3.215	0.512	nSp.p	
					C19 Clock Output		
7	STM-1 electrical 155.52 Mbps	65 kHz to 1.3 MHz	0.075 Ulpp	0.482	0.390	nSp.p	
8		500 Hz to 1.3 MHz	0.5 Ulpp	3.215	0.512	nSp.p	

* Supply voltage and operating temperature are as per Recommended Operating Conditions.

Performance Characteristics - Measured Output Jitter - Unfiltered*

	Characteristics	Typ. (U_{Ipp})	Typ. (n_{Spp})	Notes
1	C1.5o (1.544 MHz)	0.0042	2.71	
2	C2o (2.048 MHz)	0.0019	0.95	
3	$\overline{C4o}$ (4.096 MHz)	0.0037	0.92	
4	C6o (6.312 MHz)	0.0179	2.84	
5	C8o (8.192 MHz)	0.0081	0.99	
6	C8.5o (8.592 MHz)	0.0222	2.58	
7	C11o (11.184 MHz)	0.0295	2.64	
8	$\overline{C16o}$ (16.384 MHz)	0.0161	0.98	
9	C19o (19.44 MHz)	0.0125	0.64	
10	C34o (34.368 MHz)	0.0433	1.26	
11	C44o (44.736 MHz)	0.0546	1.22	
12	C155o (155.52 MHz)	0.0867	0.56	
13	$\overline{F0o}$ (8 kHz)	NA	0.44	
14	F8o (8 kHz)	NA	0.46	
15	$\overline{F16o}$ (8 kHz)	NA	0.45	

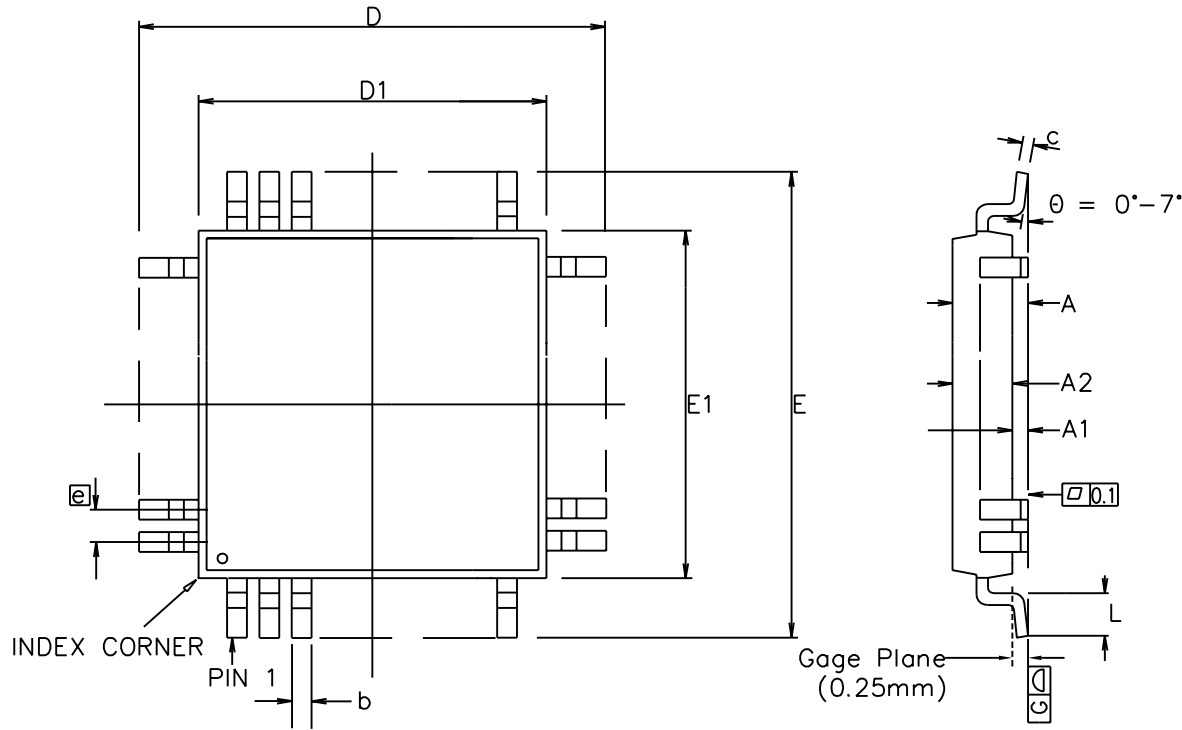

Symbol	Control Dimensions in millimetres		Altern. Dimensions in inches	
	MIN	MAX	MIN	MAX
A	---	1.60	0.002	0.063
A1	0.05	0.15	0.010	0.006
A2	1.35	1.45	0.053	0.057
D	16.00	BSC	0.630	BSC
D1	14.00	BSC	0.551	BSC
E	16.00	BSC	0.630	BSC
E1	14.00	BSC	0.551	BSC
L	0.45	0.75	0.018	0.030
e	0.65	BSC	0.026	BSC
b	0.22	0.38	0.009	0.015
c	0.09	0.20	0.004	0.008
Pin features				
N	80			
ND	20			
NE	20			
NOTE	SQUARE			

Conforms to JEDEC MS-026 BEC Iss. C

Notes:

1. Pin 1 indicator may be a corner chamfer, dot or both.
2. Controlling dimensions are in millimeters.
3. The top package body size may be smaller than the bottom package body size by a max. of 0.15 mm.
4. Dimension D1 and E1 do not include mould protrusion.
5. Dimension b does not include dambar protrusion.
6. Coplanarity, measured at seating plane G, to be 0.10 mm max.

This drawing supersedes 418/ED/51210/024 (Swindon)

© Zarlink Semiconductor 2002 All rights reserved.				
ISSUE	1	2	3	
ACN	201363	207143	212836	
DATE	28Oct96	14Jul99	21May02	
APPRD.				



		Package Code	QC
Previous package codes		Package Outline for 80 lead LQFP (14 x 14 x 1.4mm) 2.0mm Footprint	
GP / B			
		GPD00247	



**For more information about all Zarlink products
visit our Web Site at
www.zarlink.com**

Information relating to products and services furnished herein by Zarlink Semiconductor Inc. or its subsidiaries (collectively "Zarlink") is believed to be reliable. However, Zarlink assumes no liability for errors that may appear in this publication, or for liability otherwise arising from the application or use of any such information, product or service or for any infringement of patents or other intellectual property rights owned by third parties which may result from such application or use. Neither the supply of such information or purchase of product or service conveys any license, either express or implied, under patents or other intellectual property rights owned by Zarlink or licensed from third parties by Zarlink, whatsoever. Purchasers of products are also hereby notified that the use of product in certain ways or in combination with Zarlink, or non-Zarlink furnished goods or services may infringe patents or other intellectual property rights owned by Zarlink.

This publication is issued to provide information only and (unless agreed by Zarlink in writing) may not be used, applied or reproduced for any purpose nor form part of any order or contract nor to be regarded as a representation relating to the products or services concerned. The products, their specifications, services and other information appearing in this publication are subject to change by Zarlink without notice. No warranty or guarantee express or implied is made regarding the capability, performance or suitability of any product or service. Information concerning possible methods of use is provided as a guide only and does not constitute any guarantee that such methods of use will be satisfactory in a specific piece of equipment. It is the user's responsibility to fully determine the performance and suitability of any equipment using such information and to ensure that any publication or data used is up to date and has not been superseded. Manufacturing does not necessarily include testing of all functions or parameters. These products are not suitable for use in any medical products whose failure to perform may result in significant injury or death to the user. All products and materials are sold and services provided subject to Zarlink's conditions of sale which are available on request.

Purchase of Zarlink's I²C components conveys a licence under the Philips I²C Patent rights to use these components in and I²C System, provided that the system conforms to the I²C Standard Specification as defined by Philips.

Zarlink, ZL and the Zarlink Semiconductor logo are trademarks of Zarlink Semiconductor Inc.

Copyright Zarlink Semiconductor Inc. All Rights Reserved.

TECHNICAL DOCUMENTATION - NOT FOR RESALE
