

W83196R-718
W83196G-718
VIA BUFFER CHIP (4 X DDR or 2 X
DDR + 3 X SDRAM)

Date: Jan/23/2006 Revision: 2.2



W83196R-718/W83196G-718 Data Sheet Revision History

	PAGES	DATES	VERSION	WEB VERSION	MAIN CONTENTS
1	n.a.			n.a.	All of the versions before 0.50 are for internal use.
2	n.a	7/01/02	1.0	1.0	Change version and version on web site to 1.0
3	All	2/21/03	2.0	1.0	Update new form
4	4.6	12/18/03	2.1	1.0	Correction IC version, add register default value and correction some description and default value
5		01/23/06	2.2	2.2	Add lead-free part number W83196G-718
6					
7					
8					
9					
10					

Please note that all data and specifications are subject to change without notice. All the trademarks of products and companies mentioned in this data sheet belong to their respective owners.

LIFE SUPPORT APPLICATIONS

These products are not designed for use in life support appliances, devices, or systems where malfunction of these products can reasonably be expected to result in personal injury. Winbond customers using or selling these products for use in such applications do so at their own risk and agree to fully indemnify Winbond for any damages resulting from such improper use or sales.



Table of Content-

1.	GENERAL DESCRIPTION	1
2.	PRODUCT FEATURES	1
3.	PIN CONFIGURATION	2
4.	BLOCK DIAGRAM.....	3
5.	PIN DESCRIPTION.....	4
5.1	Pin Description	4
5.2	Power Pins.....	5
6.	I2C CONTROL AND STATUS REGISTERS	6
6.1	Register 6: Output Control (1 = Enable, 0 = Disable) (Default = FFH).....	6
6.2	Register 7: Output Control (1 = Enable, 0 = Disable) (Default = FFH).....	6
7.	ACCESS INTERFACE	7
7.1	Block Write protocol	7
7.2	Block Read protocol	7
7.3	Byte Write protocol	7
7.4	Byte Read protocol.....	7
8.	SPECIFICATIONS	8
8.1	ABSOLUTE MAXIMUM RATINGS	8
9.	ORDERING INFORMATION.....	8
10.	HOW TO READ THE TOP MARKING	9
11.	PACKAGE DRAWING AND DIMENSIONS.....	10

W83196R-718/W83196G-718



1. GENERAL DESCRIPTION

The W83196R-718 is a 2.5V/3.3V Clock buffer. W83196R_718 can support 4 D.D.R. DRAM DIMMs or 3 standard SDRAM and 2 D.D.R. DRAM DIMMs.

W83196R-718 can be incorporated with W83194BR-P4X or W83194BR-325.

The W83196R_718 provides I²C serial bus interface to program the registers to enable or disable each clock outputs. The W83196R_718 accepts a reference clock as its input and runs on a 3.3V or 2.5V supply.

2. PRODUCT FEATURES

- One input to 24 outputs buffer
- Supports up to 4 D.D.R. DIMMs or 3 SDRAM DIMMs and 2 D.D.R. DIMMs
- One additional output for feedback
- Low Skew outputs (< 100ps)
- Supports up to 200MHz D.D.R. SDRAM
- I²C 2-Wire serial interface and supports Byte or Block Date RW
- Power management pin for power down control
- 48-pin SSOP package

W83196R-718/W83196G-718



3. PIN CONFIGURATION

FB_output	<input type="checkbox"/>	1	●	48	<input type="checkbox"/>	SEL_DDR*
Vdd3.3_2.5	<input type="checkbox"/>	2		47	<input type="checkbox"/>	Vdd2.5
Vss	<input type="checkbox"/>	3		46	<input type="checkbox"/>	Vss
DDR0T_SDRAM0	<input type="checkbox"/>	4		45	<input type="checkbox"/>	DDR11T
DDR0C_SDRAM1	<input type="checkbox"/>	5		44	<input type="checkbox"/>	DDR11C
DDR1T_SDRAM2	<input type="checkbox"/>	6		43	<input type="checkbox"/>	DDR10T
DDR1C_SDRAM3	<input type="checkbox"/>	7		42	<input type="checkbox"/>	DDR10C
Vdd3.3_2.5	<input type="checkbox"/>	8		41	<input type="checkbox"/>	Vdd2.5
Vss	<input type="checkbox"/>	9		40	<input type="checkbox"/>	Vss
DDR2T_SDRAM4	<input type="checkbox"/>	10		39	<input type="checkbox"/>	DDR9T
DDR2C_SDRAM5	<input type="checkbox"/>	11		38	<input type="checkbox"/>	DDR9C
Vdd3.3_2.5	<input type="checkbox"/>	12		37	<input type="checkbox"/>	Vdd2.5
Buffer_IN	<input type="checkbox"/>	13		36	<input type="checkbox"/>	PD#*
Vss	<input type="checkbox"/>	14		35	<input type="checkbox"/>	Vss
DDR3T_SDRAM6	<input type="checkbox"/>	15		34	<input type="checkbox"/>	DDR8T
DDR3C_SDRAM7	<input type="checkbox"/>	16		33	<input type="checkbox"/>	DDR8C
Vdd3.3_2.5	<input type="checkbox"/>	17		32	<input type="checkbox"/>	Vdd2.5
Vss	<input type="checkbox"/>	18		31	<input type="checkbox"/>	Vss
DDR4T_SDRAM8	<input type="checkbox"/>	19		30	<input type="checkbox"/>	DDR7T
DDR4C_SDRAM9	<input type="checkbox"/>	20		29	<input type="checkbox"/>	DDR7C
DDR5T_SDRAM10	<input type="checkbox"/>	21		28	<input type="checkbox"/>	DDR6T
DDR5C_SDRAM11	<input type="checkbox"/>	22		27	<input type="checkbox"/>	DDR6C
Vdd3.3_2.5	<input type="checkbox"/>	23		26	<input type="checkbox"/>	Vss
SDATA*	<input type="checkbox"/>	24		25	<input type="checkbox"/>	SCLK*

*: Internal pull-up resistor 120K to Vdd3.3_2.5
#: Active low



4. BLOCK DIAGRAM

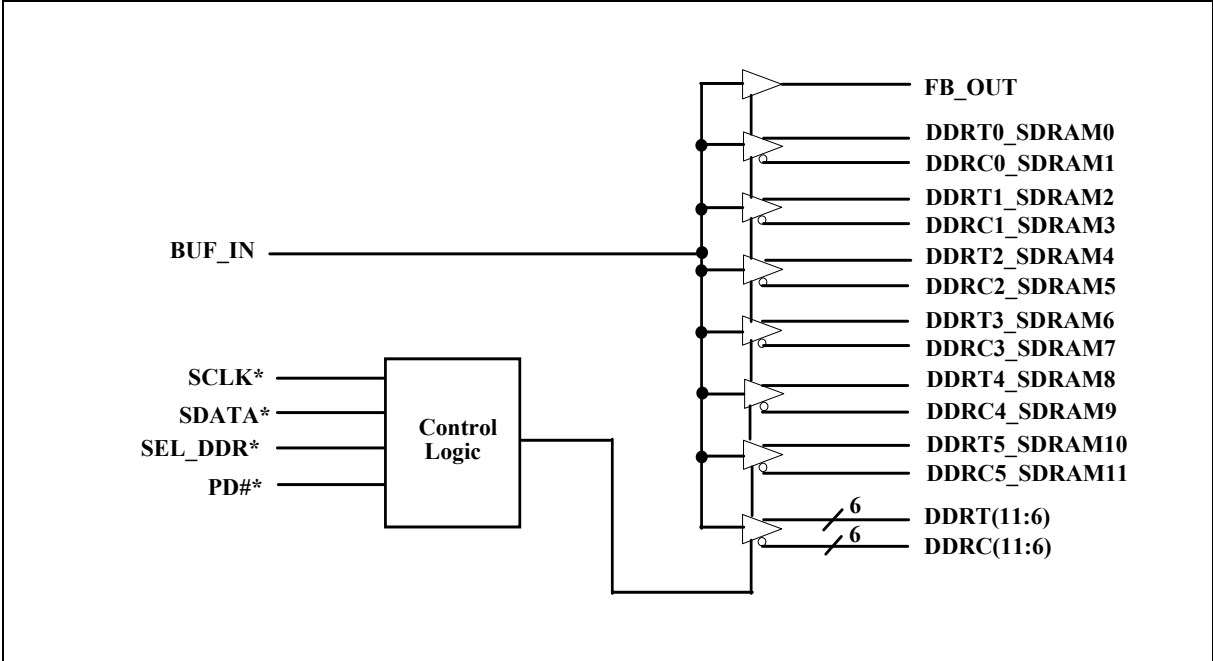



5. PIN DESCRIPTION

BUFFER TYPE SYMBOL	DESCRIPTION
IN	Input
OUT	Output
I/O	Bi-directional Pin
#	Active Low
*	Internal 120KΩ pull-up

5.1 Pin Description

PIN	PIN NAME	TYPE	DESCRIPTION
48	SEL_DDR*	IN	1= DDR only mode 0=Standard SDRAM mode When SEL_DDR is pulled high. Pin 4,5,6,7,10,11,15,16,19,20,21,22,27,28,29,30,33,34,38,39,42,43,44 and 45 will be D.D.R. outputs. Vdd3.3_2.5 should be connected to 2.5V for DDR power supply. When SEL_DDR is pulled low. Pin 4,5,6,7,10,11,15,16,19, 20,21 and 22 will be standard SDRAM outputs. Pin 27,28,29,30,33,34,38,39,42,43,44 and 45 will be DDR outputs, Vdd3.3_2.5 should be connected to 3.3V for SDRAM.
24	SDATA*	I/O	Serial data of I ² C 2-wire control interface Internal pull-up resistor 120K to Vdd3.3_2.5
25	SCLK*	IN	Serial clock of I ² C 2-wire control interface Internal pull-up resistor 120K to Vdd3.3_2.5
13	Buffer_IN	IN	Reference input from chipset. 2.5V input for DDR only mode. 3.3V for standard SDRAM mode.
1	FB_output	OUT	Feedback clock for chipset. Output voltage depends on Vdd3.3_2.5
36	PD#*	IN	Active LOW input to enable Power Down mode and All outputs will be Three-Stated Internal pull-up resistor 120K to Vdd3.3_2.5
28,30,34,39,43,45	DDR [6:11] T	OUT	Clock outputs. Copies of Buffer_IN.
27,29,33,38,42,44	DDR [6:11] C	OUT	Complementary copies of Buffer_IN
4,6,10,15,19,21	DDR [0:5] T_SDRAM [0,2,4,6,8,10]	OUT	Clock outputs. SEL_DDR=1, these pins are copies of Buffer_IN. SEL_DDR=0, these pins are copies of Buffer_IN. Voltage depends on the Vdd3.3_2.5
5,7,11,16,20,22	DDR [0:5] C_SDRAM [1,3,5,7,9,11]	OUT	Clock outputs. SEL_DDR=1, these pins are complementary copies of Buffer_IN. SEL_DDR=0, these pins are copies of Buffer_IN. Voltage depends on the Vdd3.3_2.5

W83196R-718/W83196G-718



5.2 Power Pins

PIN	PIN NAME	DESCRIPTION
2,8,12,17,23	Vdd3.3_2.5	Connected to 2.5V when SEL_DDR=1 and 3.3V when SEL_DDR=0
32,37,41,47	Vdd2.5	Power supply 2.5V.
3,9,14,18,26,31,35, 40,46	Vss	Ground



6. I2C CONTROL AND STATUS REGISTERS

Note: The Register 1~5 is reserved for main clock

6.1 Register 6: Output Control (1 = Enable, 0 = Disable) (Default = FFH)

BIT	@POWERUP	PIN	DESCRIPTION
7	1	48	SEL_DDR (Read back only)
6:5	11	-	Reserved for Winbond internal use, do not change them
4	1	-	When the pin is low -level, Pin 27,28,29,30,32,33,34,,38,39,42,43 , 44,45 will be Three-States in the SDRAM Mode.
3	1	45,44	DDR11T, DDR11C output control
2	1	43,42	DDR10T, DDR10C output control
1	1	39,38	DDR9T, DDR9C output control
0	1	34,33	DDR8T, DDR8C output control

6.2 Register 7: Output Control (1 = Enable, 0 = Disable) (Default = FFH)

BIT	@POWERUP	PIN	DESCRIPTION
7	1	30,39	DDR7T, DDR7C output control
6	1	28,27	DDR6T, DDR6C output control
5	1	21,22	DDR5T_SDRAM10, DDR5C_SDRAM11 output control
4	1	19,20	DDR4T_SDRAM8, DDR4C_SDRAM9 output control
3	1	15,16	DDR3T_SDRAM6, DDR3C_SDRAM7 output control
2	1	10,11	DDR2T_SDRAM4, DDR2C_SDRAM5 output control
1	1	6,7	DDR1T_SDRAM2, DDR1C_SDRAM3 output control
0	1	4,5	DDR0T_SDRAM0, DDR0C_SDRAM1 output control



7. ACCESS INTERFACE

The W83196R-718 provides I²C Serial Bus for microprocessor to read/write internal registers. In the W83196R-718 is provided Block Read/Block Write and Byte-Data Read/Write protocol. The I²C address is defined at 0xD2.

7.1 Block Write protocol

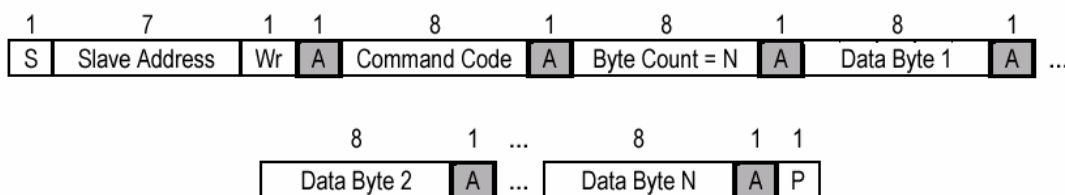

7.2 Block Read protocol

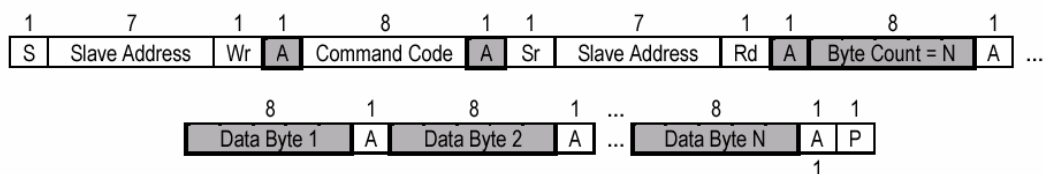

In block mode, the command code must filled 8'h00

7.3 Byte Write protocol

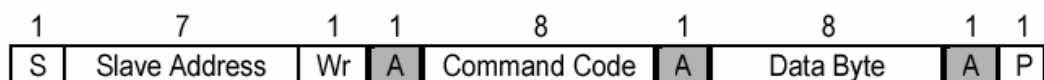

7.4 Byte Read protocol

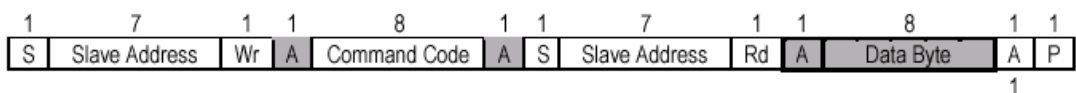

W83196R-718/W83196G-718



8. SPECIFICATIONS

8.1 ABSOLUTE MAXIMUM RATINGS

Stresses greater than those listed in this table may cause permanent damage to the device. Precautions should be taken to avoid application of any voltage higher than the maximum rated voltages to this circuit. Subjection to maximum conditions for extended periods may affect reliability. Unused inputs must always be tied to an appropriate logic voltage level (Ground or Vdd).

PARAMETER	RATING
Supply Voltage (Vdd=3.3V)	3.0V ~ 3.6V
Supply Voltage (Vdd=2.5V)	2.3V ~2.7V
Storage Temperature	- 65°C to + 150°C
Ambient Temperature	- 55°C to + 125°C
Operating Temperature	0°C to + 70°C
Input ESD protection (Human body model)	2000V

9. ORDERING INFORMATION

PART NUMBER	PACKAGE TYPE	PRODUCTION FLOW
W83196R-718	48 PIN SSOP	Commercial, 0°C to +70°C
W83196G-718	48 PIN SSOP (Pb-free package)	Commercial, 0°C to +70°C

W83196R-718/W83196G-718



10. HOW TO READ THE TOP MARKING

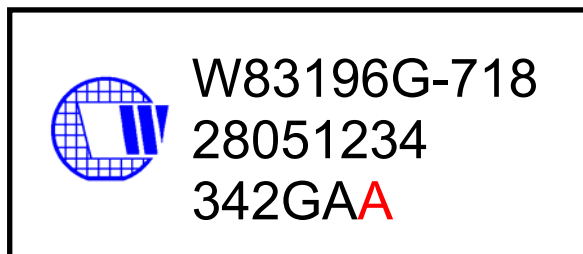
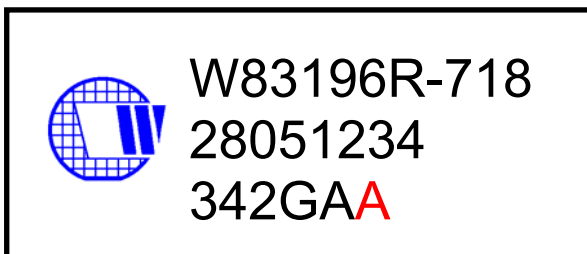

1st line: Winbond logo and the type number: W83196R-718/W83196G-718

2nd line: Tracking code 2 8051234

2: wafers manufactured in Winbond FAB 2

8051234: wafer production series lot number

3rd line: Tracking code 342 G AA

342: packages made in '2003, week 42

G: assembly house ID; O means OSE, G means GR

A: Internal use code

A: IC revision

All the trade marks of products and companies mentioned in this data sheet belong to their respective owners.



11. PACKAGE DRAWING AND DIMENSIONS

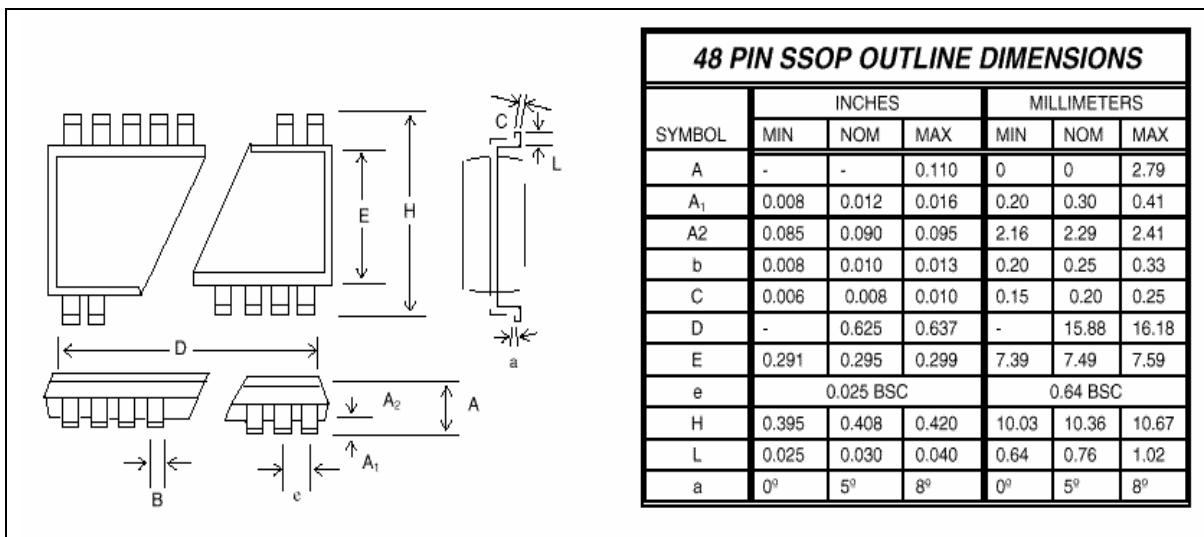

Important Notice

Winbond products are not designed, intended, authorized or warranted for use as components in systems or equipment intended for surgical implantation, atomic energy control instruments, airplane or spaceship instruments, transportation instruments, traffic signal instruments, combustion control instruments, or for other applications intended to support or sustain life. Further more, Winbond products are not intended for applications wherein failure of Winbond products could result or lead to a situation wherein personal injury, death or severe property or environmental damage could occur.

Winbond customers using or selling these products for use in such applications do so at their own risk and agree to fully indemnify Winbond for any damages resulting from such improper use or sales.



Headquarters

No. 4, Creation Rd. III,
Science-Based Industrial Park,
Hsinchu, Taiwan
TEL: 886-3-5770066
FAX: 886-3-5665577
<http://www.winbond.com.tw/>

Taipei Office

9F, No.480, Rueiguang Rd.,
Neihu District, Taipei, 114,
Taiwan, R.O.C.
TEL: 886-2-8177-7168
FAX: 886-2-8751-3579

Winbond Electronics Corporation America

2727 North First Street, San Jose,
CA 95134, U.S.A.
TEL: 1-408-9436666
FAX: 1-408-5441798

Winbond Electronics Corporation Japan

7F Daini-ueno BLDG, 3-7-18
Shinyokohama Kohoku-ku,
Yokohama, 222-0033
TEL: 81-45-4781881
FAX: 81-45-4781800

Winbond Electronics (Shanghai) Ltd.

27F, 2299 Yan An W. Rd. Shanghai,
200336 China
TEL: 86-21-62365999
FAX: 86-21-62365998

Winbond Electronics (H.K.) Ltd.

Unit 9-15, 22F, Millennium City,
No. 378 Kwun Tong Rd.,
Kowloon, Hong Kong
TEL: 852-27513100
FAX: 852-27552064

*Please note that all data and specifications are subject to change without notice.
All the trade marks of products and companies mentioned in this data sheet belong to their respective owners.*