

TUSB2036 2/3-PORT HUB FOR THE UNIVERSAL SERIAL BUS WITH OPTIONAL SERIAL EEPROM INTERFACE

SLLS372 – MARCH 2000

- Universal Serial Bus (USB) Version 1.1 Compliant
- Integrated USB Transceivers
- 3.3-V Low Power ASIC Logic
- One Upstream Port and 2-3 Programmable Downstream Ports
 - Total Number of Ports (2 or 3) Selected by Input Pin
 - Total Number of Permanently Connected Ports Is Selected by 2 Input Pins
- Two Power Source Modes
 - Self-Powered Mode
 - Bus-Powered Mode
- All Downstream Ports Support Full-Speed and Low-Speed Operations
- Power Switching and Overcurrent Reporting Is Provided Per Port or Ganged
- Supports Suspend and Resume Operations
- Suspend Status Terminal Available for External Logic Power Down
- Supports Custom Vendor ID and Product ID With External Serial EEPROM
- 3-State EEPROM Interface Allows EEPROM Sharing
- Push-Pull Outputs for $\overline{\text{PWRON}}$ Eliminate the Need for External Pullup Resistors
- Noise Filtering on $\overline{\text{OVRCUR}}$ Provides Immunity to Voltage Spikes
- Supports 6 MHz Operation Through Crystal Input or 48 MHz Input Clock
- Output Pin Available to Disable External Pullup Resistor on DP0 for 3 ms After Reset or After Change on $\overline{\text{BUSPWR}}$ and Enable Easy Implementation of On-Board Bus/Self Power Dynamic Switching Circuitry
- Available in 32-Pin LQFP Package With a 0.8 mm Pin Pitch (JEDEC – S-PQFP-G For Low-Profile Quad Flat Pack)

VF PACKAGE
(TOP VIEW)

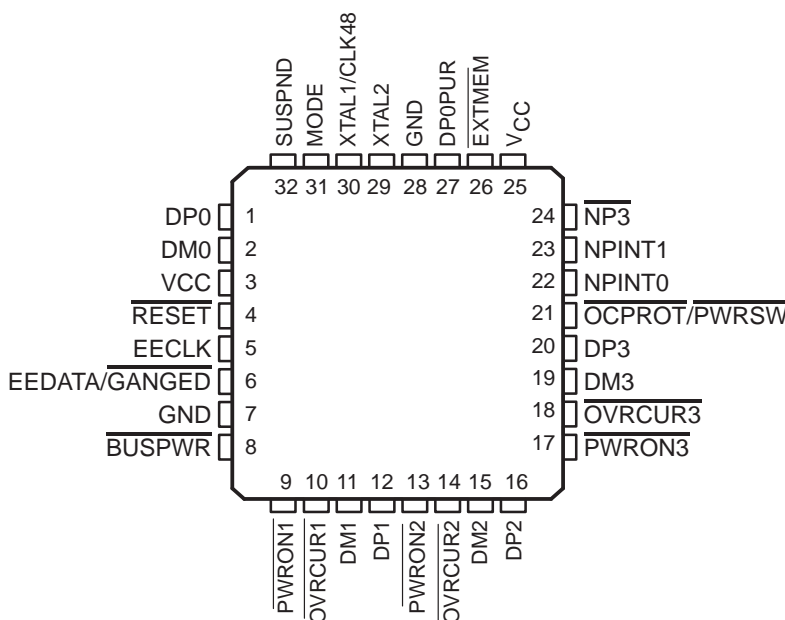

Please be aware that an important notice concerning availability, standard warranty, and use in critical applications of Texas Instruments semiconductor products and disclaimers thereto appears at the end of this data sheet.

PRODUCTION DATA information is current as of publication date. Products conform to specifications per the terms of Texas Instruments standard warranty. Production processing does not necessarily include testing of all parameters.



POST OFFICE BOX 655303 • DALLAS, TEXAS 75265

Copyright © 2000, Texas Instruments Incorporated

TUSB2036

2/3-PORT HUB FOR THE UNIVERSAL SERIAL BUS WITH OPTIONAL SERIAL EEPROM INTERFACE

SLLS372 – MARCH 2000

description

The TUSB2036 hub is a 3.3-V CMOS device that provides up to three down stream ports in compliance with the USB version 1.1 specification. Because this device is implemented with a digital state machine instead of a microcontroller, no firmware programming is required. Fully compliant USB transceivers are integrated into the ASIC for all upstream and downstream ports. The downstream ports support both full-speed and low-speed devices by automatically setting the slew rate according to the speed of the device attached to the ports. The configuration of the $\overline{\text{BUSPWR}}$ terminal selects either the bus-powered or the self-powered mode. The introduction of the DP0 pull-up resistor disable pin, DP0PUR, makes it much easier to implement an on-board bus/self-power dynamic-switching circuitry. With the new function pin, the end equipment vendor can reduce the total board cost while adding additional product value.

The $\overline{\text{EXTMEM}}$ (Pin 26) enables or disables the optional EEPROM interface. When $\overline{\text{EXTMEM}}$ is high, the vendor and product IDs (VID and PID) use defaults, such that the message displayed during enumeration is *General Purpose USB Hub*. For this configuration, pin 6 functions as the $\overline{\text{GANGED}}$ input pin and the EECLK (Pin 5) is unused. If custom VID and PID descriptors are desired, the $\overline{\text{EXTMEM}}$ must be tied low ($\overline{\text{EXTMEM}} = 0$) and a SGS Thompson M93C46 or equivalent EEPROM must be used to store the programmable VID, PID and $\overline{\text{GANGED}}$ value. For this configuration, pin 5 and pin 6 function as the EEPROM interface signals with pin 5 as EECLK and pin 6 as EEDATA respectively.

The TUSB2036 supports both bus-powered and self-powered modes. External power management devices such as the TPS2044 are required to control the 5 V-power source switching (on/off) to the downstream ports and detect over-current condition from the downstream ports individually or ganged. Outputs from external power devices provide over-current inputs to the TUSB2036 $\overline{\text{OVRCUR}}$ pins in case of an over-current condition, the corresponding $\overline{\text{PWRON}}$ pins will be disabled by the TUSB2036. In the ganged mode, all $\overline{\text{PWRON}}$ signals transitions simultaneously, and any $\overline{\text{OVRCUR}}$ input can be used. In the nonganged mode, the $\overline{\text{PWRON}}$ outputs and $\overline{\text{OVRCUR}}$ inputs operate on a per port basis.

The TUSB2036 provides the flexibility of using either a 6-MHz or a 48-MHz clock. The logic level of the MODE terminal controls the selection of the clock source. When MODE is low, the output of the internal APLL circuitry is selected to drive the internal core of the chip. When MODE is high, the XTAL1 input is selected as the input clock source and the APLL circuitry is powered down and bypassed. The internal oscillator cell is also powered down while MODE is high. For 6-MHz operation, TUSB2036 requires a 6-MHz clock signal on XTAL1 pin (with XTAL2 for a crystal) from which its internal APLL circuitry generates a 48 MHz internal clock to sample the data from the upstream port. For 48-MHz operation, the clock cannot be generated with a crystal, using the XTAL2 output, since the internal oscillator cell only supports fundamental frequency. If low power suspend and resume are desired, a passive crystal or resonator must be used, although the hub supports the flexibility of using any device that generates a 6-MHz clock. Because most oscillators cannot be stopped while power is on, their use prohibits low-power suspend, which depends on disabling the clock. When the oscillator is used, by connecting its output to XTAL1 terminal and leaving XTAL2 terminal open, its TTL output level can not exceed 3.6 V. If a 6 MHz oscillator is used, it must be stopped at logic low whenever SUSPND is high. For crystal or resonator implementations, the XTAL1 terminal is the input and the XTAL2 terminal is used as the feedback path. A sample crystal tuning circuit is shown in Figure 7.



POST OFFICE BOX 655303 • DALLAS, TEXAS 75265

description (continued)

The hub silicon can accurately reflect the system port configuration by the $\overline{NP3}$ and NPINT1-0 pins. When $\overline{NP3}$ is low, the hub is configured as a 3-port hub; when it is high, the hub is configured as a 2-port hub. The NPINT1-0 pins tell the hub silicon how many ports have permanently attached devices, according to Table 1.

Table 1. System Port Configuration

NPINT1-0	PORT AVAILABILITY	HUB DESCRIPTOR DEVICE REMOVABLE FIELD (7-0)
00	All ports are available through external USB connectors	00000000
01	Port 1 has a permanently attached device; ports 2 and 3 are externally available	00000010
10	Ports 1 and 2 have permanently attached devices; port 3 is externally available	00000110
11	All ports have permanently attached devices	$\overline{NP3}$ high: 00000110 NP3 low: 00001110
NPINT1-0	COMPOUND DEVICE OR NOT	HUB DESCRIPTOR WITH HUB CHARACTERISTICS FIELD BIT 2
00	Hub is not part of a compound device	0
01, 10, 11	Hub is part of a compound device	1

TUSB2036

2/3-PORT HUB FOR THE UNIVERSAL SERIAL BUS WITH OPTIONAL SERIAL EEPROM INTERFACE

SLLS372 – MARCH 2000

Terminal Functions

TERMINAL NAME	VF	I/O	DESCRIPTION
<u>BUSPWR</u>	8	I	Power source indicator. <u>BUSPWR</u> is an active low input that indicates whether the downstream ports source their power from the USB cable or a local power supply. For the bus-power mode, this pin should be pulled low, and for the self-powered mode, this pin should be pulled to 3.3 V. Input must not change dynamically during operation.
DM0	2	I/O	Root port USB differential data minus. DM0 paired with DP0 constitutes the upstream USB port.
DM1 – DM3	11, 15, 19	I/O	USB differential data minus. DM1 – DM3 paired with DP1 – DP3 support up to three downstream USB ports.
DP0	1	I/O	Root port USB differential data plus. DP0 paired with DM0 constitutes the upstream USB port.
DP0PUR	27	O	Pull-up resistor connection. Whenever a system reset occurs (<u>RESET</u> being driven to low, but not USB reset) or any logic level change on <u>BUSPWR</u> terminal, DP0PUR output goes to inactive Low until the internal counter reaches a 3 ms time period. After the counter expires, DP0PUR is driven to the V_{CC} (3.3 V) level thereafter until the next system reset event or <u>BUSPWR</u> logic level change.
DP1 – DP3	12, 16, 20	I/O	USB differential data plus. DP1 – DP3 paired with DM1 – DM3 support up to three downstream USB ports.
EECLK	5	O	EEPROM serial clock. When <u>EXTMEM</u> is high, the EEPROM interface is disabled. The EECLK pin is disabled and should be left floating (unconnected). When <u>EXTMEM</u> is low, EECLK acts as a 3-state serial clock output to the EEPROM with a 100 μ A internal pull-down.
<u>EEDATA/</u> <u>GANGED</u>	6	I/O	EEPROM serial data/power management mode indicator. When <u>EXTMEM</u> is high, <u>EEDATA/GANGED</u> selects between <u>gang</u> and per-port power overcurrent detection for the downstream ports. When <u>EXTMEM</u> is low, <u>EEDATA/GANGED</u> acts as a serial data I/O for the EEPROM and is internally pulled down with a 100 μ A pull-down. This standard TTL input must not change dynamically during operation.
<u>EXTMEM</u>	26	I	EEPROM read enable. When <u>EXTMEM</u> is high, the serial EEPROM interface of the device is disabled. When <u>EXTMEM</u> is low, terminals 5 and 6 are configured as the clock and data pins of the serial EEPROM interface, respectively.
GND	7, 28		Ground. GND terminals must be tied to ground for proper operation.
<u>OCPROT/</u> <u>PWRSW</u>	21	I	Overcurrent Protection for bus-powered hub (active low). /Power Switching for self-powered hub (active low). The pin has a different meaning for the bus or self-powered hub. If the pin is logic-high the internal pull-down is disabled. (see Notes 1 and 2).
<u>OVRCUR1</u> – <u>OVRCUR3</u>	10, 14, 18	I	overcurrent input. <u>OVRCUR1</u> – <u>OVRCUR3</u> are active low. For per-port overcurrent detection, one overcurrent input is available for each of the three downstream ports. In the ganged mode, any <u>OVRCUR</u> input may be used and all <u>OVRCUR</u> pins should be tied together. <u>OVRCUR</u> pins are active low inputs with noise filtering logic. <u>OVRCUR3</u> has an internal pull-up that can be enabled for the 2-port operation.

NOTES: 1. If the hub is implemented to be **bus-powered** (via BUSPWR tying to GND):

- TUSB2036 reports to the host that the hub end-product downstream ports are power-switched (this is required by the USB 1.1 Specification). Hub end product vendor has to ensure the actual end product implementation meets this specification requirement.
 - Pin 21 acts as overcurrent protection (OCPROT) implementation indication pin for the bus-powered hub. The overcurrent protection implementation is reported through the wHubCharacteristics. D4-bit in the hub descriptor.
 - When OCPROT is low, the TUSB2036 reports to the host that the hub end-product provides overcurrent protection and the wHubCharacteristics. D4-bit is set to 0.
 - When OCPROT is high, the TUSB2036 reports to the host that the hub end-product does not provide overcurrent protection and the wHubCharacteristics. D4-bit is set to 1.
2. If the hub is implemented to be **self-powered** (via BUSPWR tying to 3.3-V V_{CC}):
- TUSB2036 reports to the host that the hub end-product provides overcurrent protection to the downstream ports (this is required by the USB 1.1 Specification). Hub end product vendor has to ensure the actual end-product implementation meets this specification requirement.
 - Pin 21 acts as power switching (PWRSW) implementation indication pin for the self-powered hub. The power switching implementation is reported through the bPwrOn2PwrGood field in the hub descriptor.
 - When PWRSW is low, the TUSB2036 reports to the host that the hub end-product has port power switching at the downstream ports and the bPwrOn2PwrGood is set to 50 units (100 ms).
 - When PWRSW is high, the TUSB2036 reports to the host that the hub end-product does not have port power switching at the downstream ports and the bPwrOn2PwrGood is set to 0 units (0 ms).



TUSB2036
2/3-PORT HUB FOR THE UNIVERSAL SERIAL BUS
WITH OPTIONAL SERIAL EEPROM INTERFACE

SLLS372 – MARCH 2000

Terminal Functions (Continued)

TERMINAL NAME	VF	I/O	DESCRIPTION
$\overline{\text{PWRON1}}$ – $\overline{\text{PWRON3}}$	9, 13, 17	O	Power-on/-off control signals. $\overline{\text{PWRON1}}$ – $\overline{\text{PWRON3}}$ are active low, push-pull outputs. Push-pull outputs eliminate the pullup resistors which open-drain outputs require. However, the external power switches that connect to these pins must be able to operate with 3.3-V inputs because these outputs cannot drive 5-V signals.
$\overline{\text{RESET}}$	4	I	Reset. $\overline{\text{RESET}}$ is an active low TTL input with hysteresis and must be asserted at power up. When $\overline{\text{RESET}}$ is asserted, all logic is initialized. Generally, a reset with a pulse width between 100 μs and 1 ms is recommended after 3.3-V V_{CC} reaching its 90%. The clock signal must be active during the last 60 μs of the reset window.
SUSPND	32	O	Suspend status. SUSPND is an active high output available for external logic power-down operations. During the suspend mode, SUSPND is high. SUSPND is low for normal operation.
MODE	31	I	Mode select. When MODE is low, the APLL output clock is selected as the clock source to drive the internal core of the chip and 6-MHz crystal or oscillator can be used. When MODE is high, the clock on XTAL1/CLK48 is selected as the clock source and 48-MHz oscillator or other on-board clock source can be used.
$\overline{\text{NP3}}$	24	I	Number of ports is 3. Active low input. A logic 0 configures the system to use 3 ports. A logic 1, configures the system to use 2 ports.
NPINT1–0	23, 22	I	Number of ports internal to hub system, which are permanently attached (see Table 1)
VCC	3, 25		3.3-V supply voltage
XTAL1/CLK48	30	I	Crystal 1/48-MHz Clock Input. When MODE is low, XTAL1/CLK48 is a 6-MHz crystal input with 50% duty cycle. An internal APLL generates the 48-MHz and 12-MHz clocks used internally by the ASIC logic. When MODE is high, XTAL1/CLK48 acts as the input of the 48 MHz clock and the internal APLL logic is bypassed.
XTAL2	29	O	Crystal 2. XTAL2 is a 6-MHz crystal output. This terminal should be left open when using an oscillator.



TUSB2036

2/3-PORT HUB FOR THE UNIVERSAL SERIAL BUS WITH OPTIONAL SERIAL EEPROM INTERFACE

SLLS372 – MARCH 2000

absolute maximum ratings over operating free-air temperature range (unless otherwise noted)†

Supply voltage range, V_{CC} (see Note 1)	-0.5 V to 3.6 V
Input voltage range, V_I	-0.5 V to $V_{CC} + 0.5$ V
Output voltage range, V_O	-0.5 V to $V_{CC} + 0.5$ V
Input clamp current, I_{IK} , ($V_I < 0$ V or $V_I > V_{CC}$)	± 20 mA
Output clamp current, I_{OK} , ($V_O < 0$ V or $V_O > V_{CC}$)	± 20 mA
Storage temperature range, T_{stg}	-65°C to 150°C
Operating free-air temperature range, T_A	0°C to 70°C

† Stresses beyond those listed under “absolute maximum ratings” may cause permanent damage to the device. These are stress ratings only, and functional operation of the device at these or any other conditions beyond those indicated under “recommended operating conditions” is not implied. Exposure to absolute-maximum-rated conditions for extended periods may affect device reliability.

NOTE 3: All voltage levels are with respect to GND.

recommended operating conditions

	MIN	NOM	MAX	UNIT
Supply voltage, V_{CC}	3	3.3	3.6	V
Input voltage, TTL/LVCMOS, V_I	0		V_{CC}	V
Output voltage, TTL/LVCMOS, V_O	0		V_{CC}	V
High-level input voltage, signal-ended receiver, $V_{IH(REC)}$	2		V_{CC}	V
Low-level input voltage, signal-ended receiver, $V_{IL(REC)}$			0.8	V
High-level input voltage, TTL/LVCMOS, $V_{IH(TTL)}$	2		V_{CC}	V
Low-level input voltage, TTL/LVCMOS, $V_{IL(TTL)}$	0		0.8	V
Operating free-air temperature, T_A	0		70	°C
External series, differential driver resistor, $R_{(DRV)}$	22 (-5%)		22 (+5%)	Ω
Operating (dc differential driver) high-speed mode, $f_{(OPRH)}$			12	Mb/s
Operating (dc differential driver) low-speed mode, $f_{(OPRL)}$			1.5	Mb/s
Common mode, input range, differential receiver, $V_{(ICR)}$	0.8		2.5	V
Input transition times, t_t , TTL/LVCMOS	0		25	ns
Junction temperature range, T_J	0		115	°C



TUSB2036

2/3-PORT HUB FOR THE UNIVERSAL SERIAL BUS

WITH OPTIONAL SERIAL EEPROM INTERFACE

SLLS372 – MARCH 2000

electrical characteristics over recommended ranges of operating free-air temperature and supply voltage (unless otherwise noted)

PARAMETER		TEST CONDITIONS	MIN	MAX	UNIT	
V _{OH}	High-level output voltage	TTL/LVCMOS	I _{OH} = -4 mA	V _{CC} - 0.5	V	
		USB data lines	R _(DRV) = 15 kΩ, to GND	2.8		
			I _{OH} = -12 mA (without R _(DRV))	V _{CC} - 0.5		
V _{OL}	Low-level output voltage	TTL/LVCMOS	I _{OL} = 4 mA	0.5	V	
		USB data lines	R _(DRV) = 1.5 kΩ to 3.6 V	0.3		
			I _{OL} = 12 mA (without R _(DRV))	0.5		
V _{IT+}	Positive input threshold voltage	TTL/LVCMOS		1.8	V	
		Single-ended	0.8 V ≤ V _{ICR} ≤ 2.5 V	1.8	V	
V _{IT-}	Negative-input threshold voltage	TTL/LVCMOS		0.8	V	
		Single-ended	0.8 V ≤ V _{ICR} ≤ 2.5 V	1	V	
V _{hys}	Input hysteresis [†] (V _{T+} - V _{T-})	TTL/LVCMOS		0.3	0.7	V
		Single-ended	0.8 V ≤ V _{ICR} ≤ 2.5 V	300	500	mV
I _{OZ}	High-impedance output current	TTL/LVCMOS	V = V _{CC} or GND [‡]	±10	μA	
		USB data lines	0 V ≤ V _O ≤ V _{CC}	±10	μA	
I _{IL}	Low-level input current	TTL/LVCMOS	V _I = GND	-1	μA	
I _{IH}	High-level input current	TTL/LVCMOS	V _I = V _{CC}	1	μA	
z _{o(DRV)}	Driver output impedance	USB data lines	Static V _{OH} or V _{OL}	7.1	19.9	Ω
V _{ID}	Differential input voltage	USB data lines	0.8 V ≤ V _{ICR} ≤ 2.5 V	0.2		V
I _{CC}	Input supply current		Normal operation	40	mA	
			Suspend mode	1	μA	

[†] Applies for input buffers with hysteresis

[‡] Applies for open drain buffers

differential driver switching characteristics over recommended ranges of operating free-air temperature and supply voltage, C_L = 50 pF (unless otherwise noted)

full speed mode

PARAMETER	TEST CONDITIONS	MIN	MAX	UNIT	
t _r	Transition rise time for DP or DM	See Figure 1 and Figure 2	4	20	ns
t _f	Transition fall time for DP or DM	See Figure 1 and Figure 2	4	20	ns
t _(RFM)	Rise/fall time matching [§]	(t _r /t _f) × 100	90%	110%	
V _{O(CRS)}	Signal crossover output voltage [§]		1.3	2.0	V

[§] Characterized only. Limits approved by design and are not production tested

low speed mode

PARAMETER	TEST CONDITIONS	MIN	MAX	UNIT	
t _r	Transition rise time for DP or DM [§]	C _L = 200 pF to 600 pF, See Figure 1 and Figure 2	75	300	ns
t _f	Transition fall time for DP or DM [§]	C _L = 200 pF to 600 pF, See Figure 1 and Figure 2	75	300	ns
t _(RFM)	Rise/fall time matching [§]	(t _r /t _f) × 100	80%	120%	
V _{O(CRS)}	Signal crossover output voltage [§]	C _L = 200 pF to 600 pF	1.3	2.0	V

[§] Characterized only. Limits approved by design and are not production tested



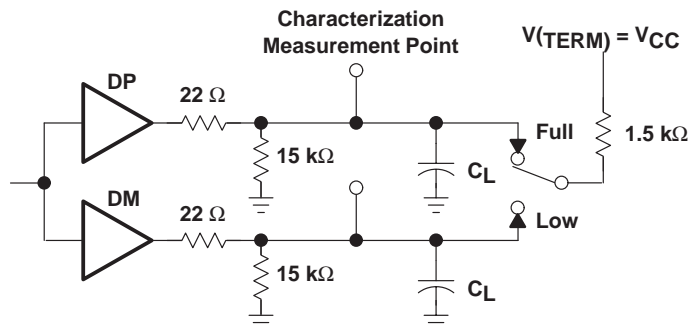
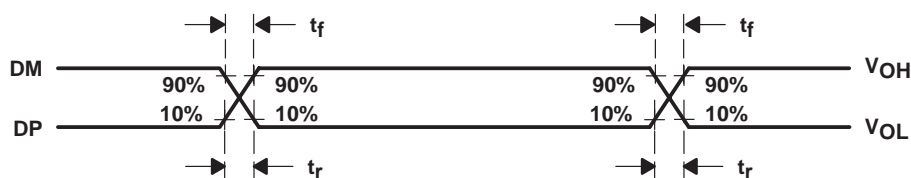

Figure 1. Differential Driver Switching Load



NOTE: The t_r/t_f ratio is measured as $t_r(DP)/t_f(DM)$ and $t_r(DM)/t_f(DP)$ at each crossover point.

Figure 2. Differential Driver Timing Waveforms

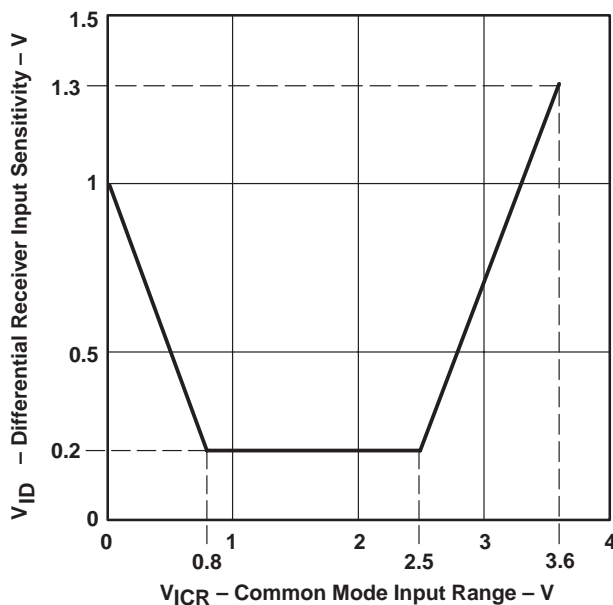

Figure 3. Differential Receiver Input Sensitivity vs Common Mode Input Range

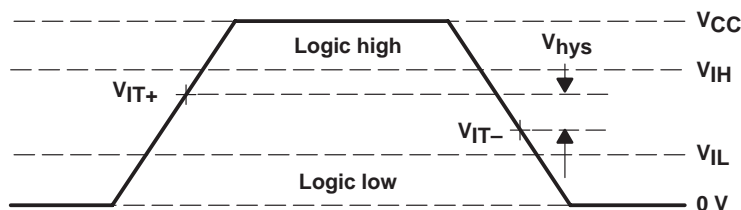

Figure 4. Single-Ended Receiver Input Signal Parameter Definitions

APPLICATION INFORMATION

A major advantage of USB is the ability to connect 127 functions configured in up to six logical layers (tiers) to a single personal computer (see Figure 5).

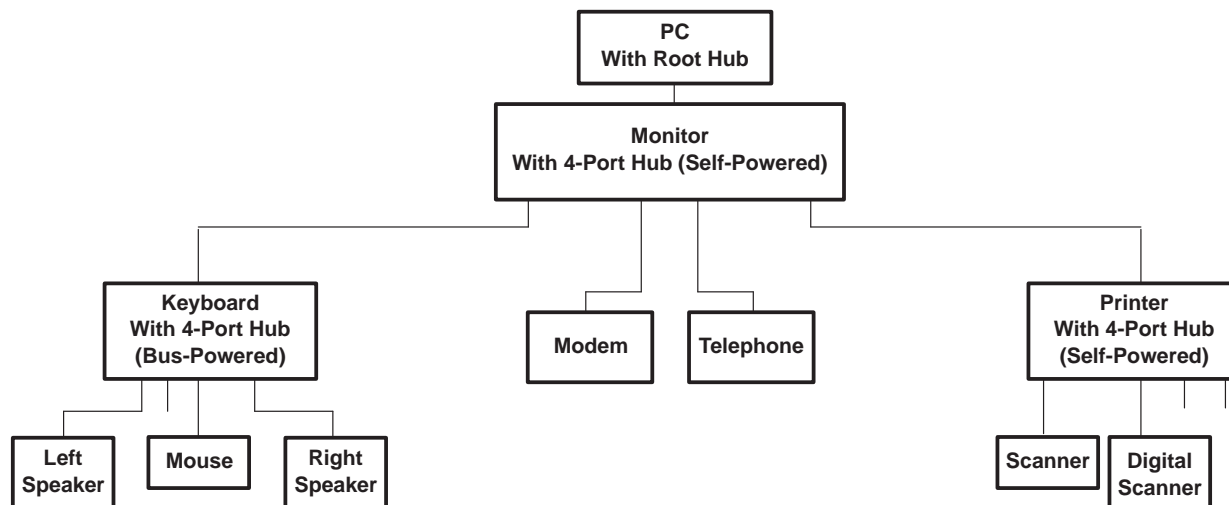

Figure 5. USB Tiered Configuration Example

Another advantage of USB is that all peripherals are connected using a standardized four-wire cable that provides both communication and power distribution. The power configurations are bus-powered and self-powered modes. The maximum current that may be drawn from the USB 5-V line during power up is 100 mA. For the bus-powered mode, a hub can draw a maximum of 500 mA from the 5-V line of the USB cable. A bus-powered hub must always be connected downstream to a self-powered hub unless it is the only hub connected to the PC and there are no high-powered functions connected downstream. In the self-powered mode, the hub is connected to an external power supply and can supply up to 500 mA to each downstream port. High-powered functions may draw a maximum of 500 mA from each downstream port and may only be connected downstream to self-powered hubs. Per the USB specification, in the bus-powered mode, each downstream port can provide a maximum of 100 mA of current, and in the self-powered mode, each downstream port can provide a maximum of 500 mA of current.

Both bus-powered and self-powered hubs require overcurrent protection for all downstream ports. The two types of protection are individual port management (individual port basis) or ganged port management (multiple port basis). Individual port management requires power management devices for each individual downstream port, but adds robustness to the USB system because, in the event of an overcurrent condition, the USB host only powers down the port that has the condition. The ganged configuration uses fewer power management devices and thus has lower system costs, but in the event of an overcurrent condition on any of the downstream ports, all the ganged ports are disabled by the USB host.

Using a combination of the $\overline{\text{BUSPWR}}$ and $\overline{\text{EEDATA/GANGED}}$ inputs, the TUSB2036 supports four modes of power management: bus-powered hub with either individual port power management or ganged port power management, and the self-powered hub with either individual port power management or ganged port power management. Texas Instruments supplies the complete hub solution because we offer this TUSB2036, the TUSB2043/TUSB2046 (4-port), the TUSB2077A (7-port) and the TUSB2140B (4-port with I²C) hubs along with the power management chips needed to implement a fully USB Specification 1.1 compliant system.

APPLICATION INFORMATION

USB design notes

The following sections provide block diagram examples of how to implement the TUSB2036 device. Please note, even though no resistors are shown, pullup, pulldown and series resistors must still be used to properly implement this device.

Figure 6 is a block diagram example of how to connect the external EEPROM if a custom product ID and vendor ID are desired.

Figure 7 is an example of how to generate the 6-MHz clock signal. Figure 8 shows the EEPROM read operation timing diagram. Figures 9, 10, and 11 illustrate how to connect the TUSB2036 device for different power source and port power management combinations.

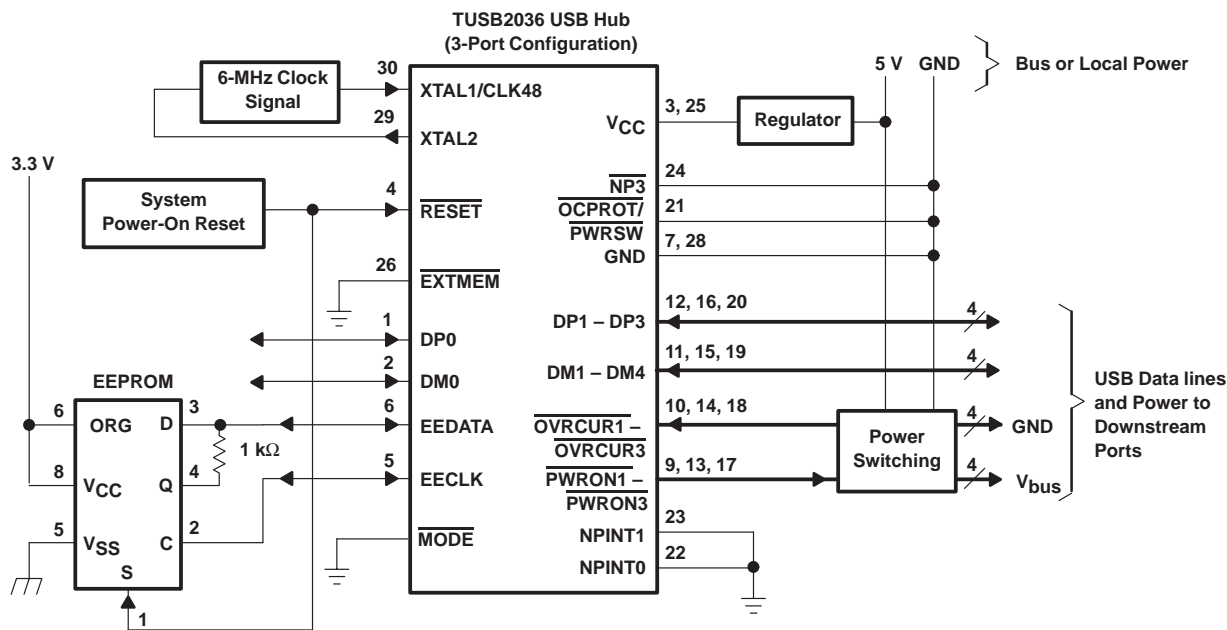
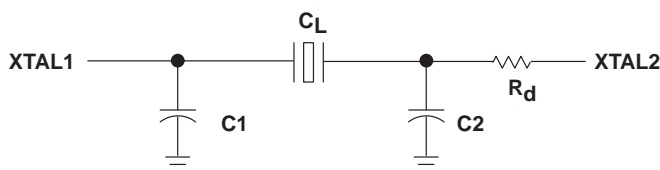

Figure 6. Typical Application of the TUSB2036 USB Hub



NOTE A: Figure 7 assumes a 6 MHz fundamental crystal that is parallel loaded. The component values of C1, C2 and R_d were determined using a crystal from Fox Electronics – part number HC49U–6.00MHz30\50\0 ±70\20 which means ±30 ppm at 25°C and 50 ppm from 0°C to 70°C. The characteristics for the crystal are load capacitance (C_L) of 20 pF, maximum shunt capacitance (C_0) of 7 pF and the maximum ESR of 50 Ω. In order to insure enough negative resistance, use $C1 = C2 = 27$ pF. The resistor R_d is used to trim the gain, and $R_d = 1.5$ kΩ is recommended.

Figure 7. Crystal Tuning Circuit

TUSB2036

2/3-PORT HUB FOR THE UNIVERSAL SERIAL BUS

WITH OPTIONAL SERIAL EEPROM INTERFACE

SLLS372 – MARCH 2000

APPLICATION INFORMATION

programming the EEPROM

An SGS Thompson M93C46 EEPROM or equivalent is used for storing the programmable VID and PID. When the EEPROM interface is enabled ($\overline{\text{EXTMEM}} = 0$), the EECLK and EEDATA are internally pulled down (100 μA) inside the TUSB2036. The internal pulldowns are disabled when the EEPROM interface is disabled ($\overline{\text{EXTMEM}} = 1$).

The EEPROM is programmed with the three 16-bit locations as shown in Table 1. Connecting pin 6 of the EEPROM high (ORG = 1) organizes the EEPROM memory into 64 \times 16 bit words.

Table 2. EEPROM Memory Map

ADDRESS	D15	D14	D13	D12–D8	D7–D0
00000	0	GANGED	00000	00000	00000000
00001	VID High-byte				VID Low-byte
00010	PID High-byte				PID Low-byte
XXXXXXXX					

The D and Q signals of the EEPROM must be tied together using a 1 k Ω resistor with the common I/O operations forming a single-wire bus. After system power-on reset, the TUSB2036 performs a one-time access read operation from the EEPROM if the $\overline{\text{EXTMEM}}$ pin is pulled low and the chip select(s) of the EEPROM is connected to the system power-on reset. Initially, the EEDATA pin will be driven by the TUSB2036 to send a start bit (1), which is followed by the read instruction (10) and the starting-word address (00000). Once the read instruction is received, the instruction and address are decoded by the EEPROM, which then sends the data to the output shift register. At this point, the hub stops driving the EEDATA pin and the EEPROM starts driving. A dummy (0) bit is then output and the first three 16-bit words in the EEPROM are output with the most significant bit (MSB) first.

The output data changes are triggered by the rising edge of the clock provided by the TUSB2036 on the EECLK pin. The *SGS-Thompson M93C46* EEPROM is recommended because it advances to the next memory location by automatically incrementing the address internally. Any EEPROM used must have the automatic internal address advance function. After reading the three words of data from the EEPROM, the TUSB2036 puts the EEPROM interface into a high-impedance condition (pulled down internally) to allow other logic to share the EEPROM. The EEPROM read operation is summarized in Figure 8. For more details on EEPROM operation, refer to *SGS-Thompson Microelectronics M93C46 Serial Microwire Bus EEPROM* data sheet.



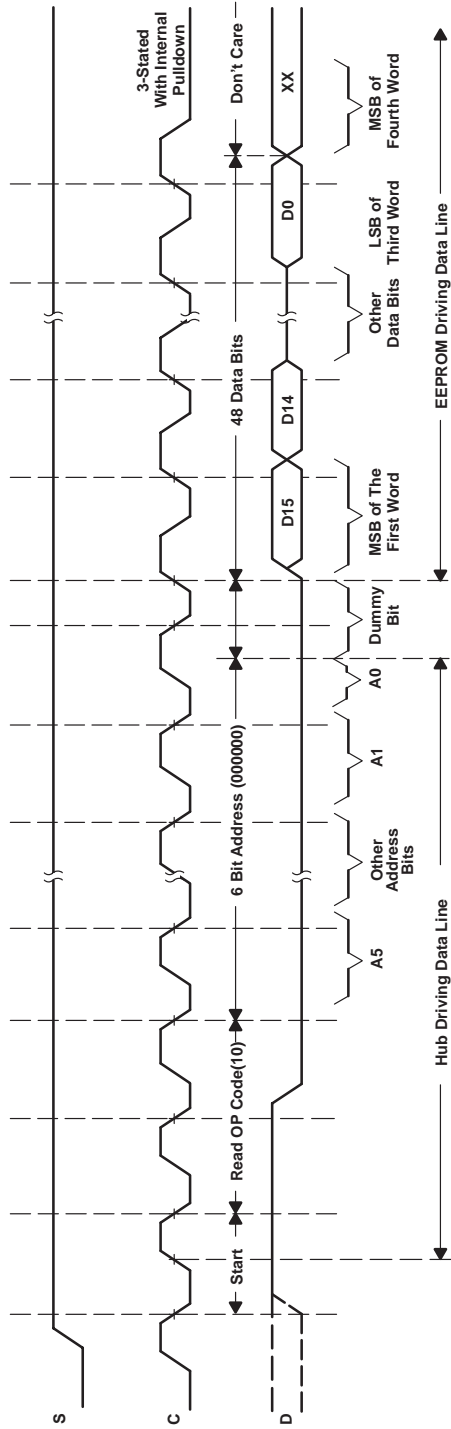

Figure 8. EEPROM Read Operation Timing Diagram

TUSB2036 2/3-PORT HUB FOR THE UNIVERSAL SERIAL BUS WITH OPTIONAL SERIAL EEPROM INTERFACE

SLLS372 – MARCH 2000

APPLICATION INFORMATION

bus-powered hub, ganged port-power management

When used in bus-powered mode, the TUSB2036 supports up to three downstream ports by controlling a TPS2041 device which is capable of supplying 100 mA of current to each downstream port. Bus-powered hubs must implement power switching to ensure current demand is held below 100 mA when the hub is hot-plugged into the system. Utilizing the TPS2041 for ganged power management provides overcurrent protection for the downstream ports. The SN75240 transient suppressors reduce inrush current and voltage spikes on the data lines. The OVR CUR signals should be tied together for a ganged operation.

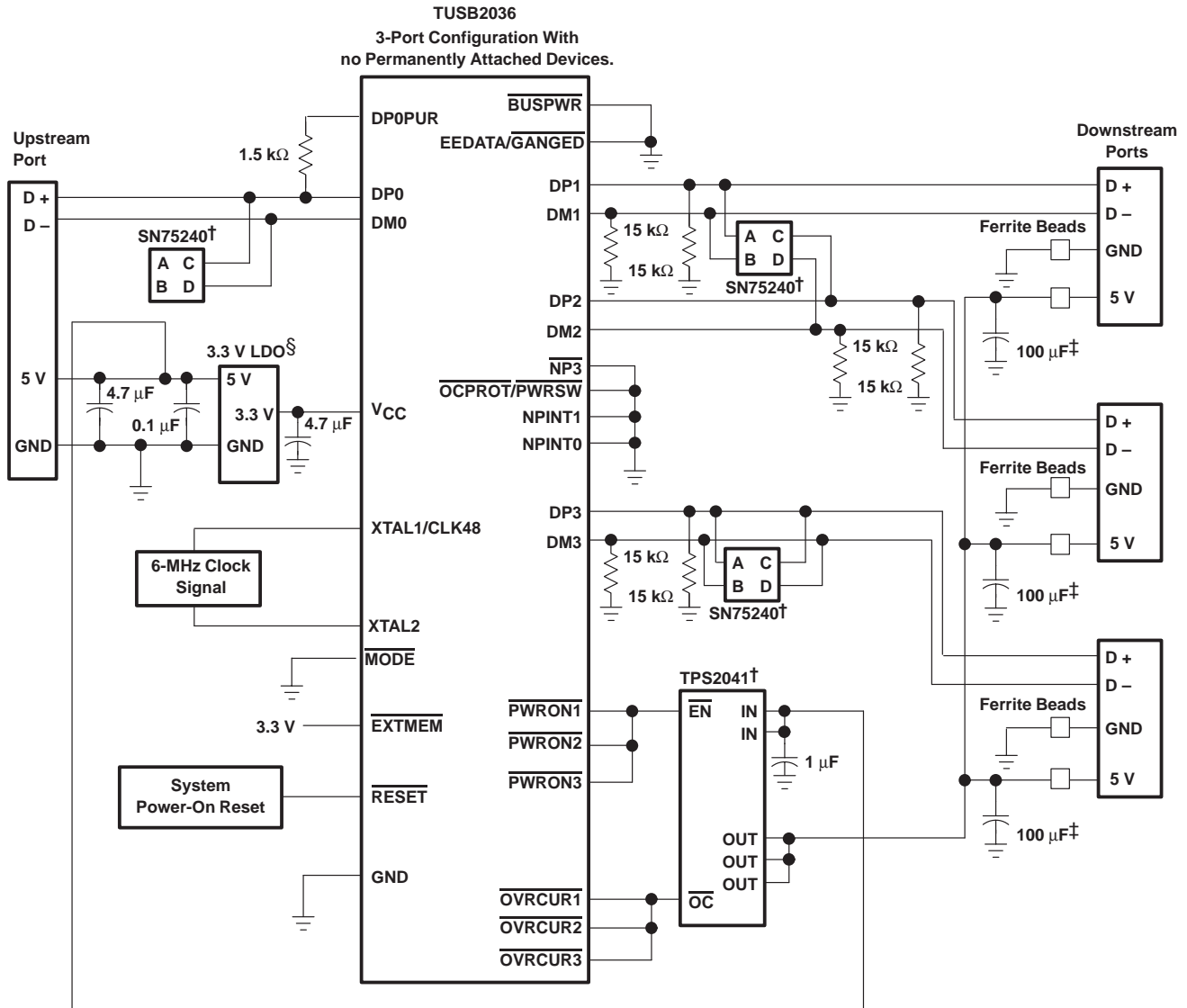

† TPS2041 and SN75240 are Texas Instruments devices.

‡ 120 μF per hub is the minimum required per the USB specification, version 1.1. However, TI recommends a 100 μF low ESR tantalum capacitor per port for immunity to voltage droop.

§ LDO is a 5 V to 3.3 V voltage regulator

Figure 9. TUSB2036 Bus-Powered Hub, Ganged Port-Power Management Application



POST OFFICE BOX 655303 • DALLAS, TEXAS 75265

APPLICATION INFORMATION

bus-powered hub with a permanently attached high speed device, ganged port-power management

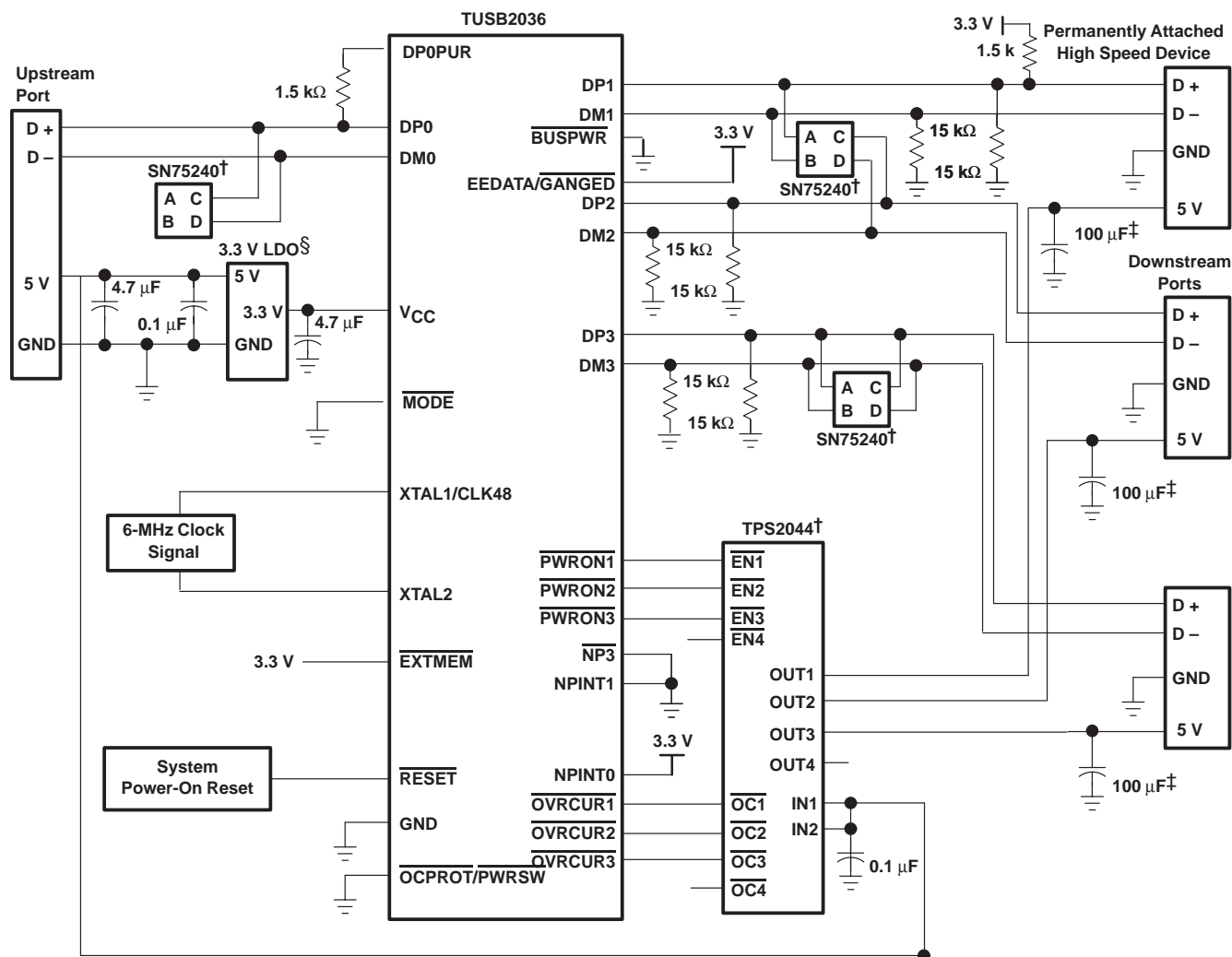

† TPS2042 and SN75240 are Texas Instruments devices. Two TPS2042 devices can be substituted for the TPS2044.

‡ 120 μF per hub is the minimum required per the USB specification, version 1.1. However, TI recommends a 100 μF low ESR tantalum capacitor per port for immunity to voltage droop.

§ LDO is a 5 V to 3.3 V voltage regulator

Figure 10. TUSB2036 Bus-Powered Hub With a Permanently Attached High Speed Device, Individual Port-Power Management Application

TUSB2036 2/3-PORT HUB FOR THE UNIVERSAL SERIAL BUS WITH OPTIONAL SERIAL EEPROM INTERFACE

SLLS372 – MARCH 2000

APPLICATION INFORMATION

self-powered hub, ganged port-power management

The TUSB2036 can also be implemented for ganged port-power management in a self-powered configuration. The implementation is very similar to the bus-powered example with the exception that a self-powered port supplies 500 mA of current to each downstream port. The overcurrent protection can be provided by a TPS2044 quad device or a TPS2024 single power switch.

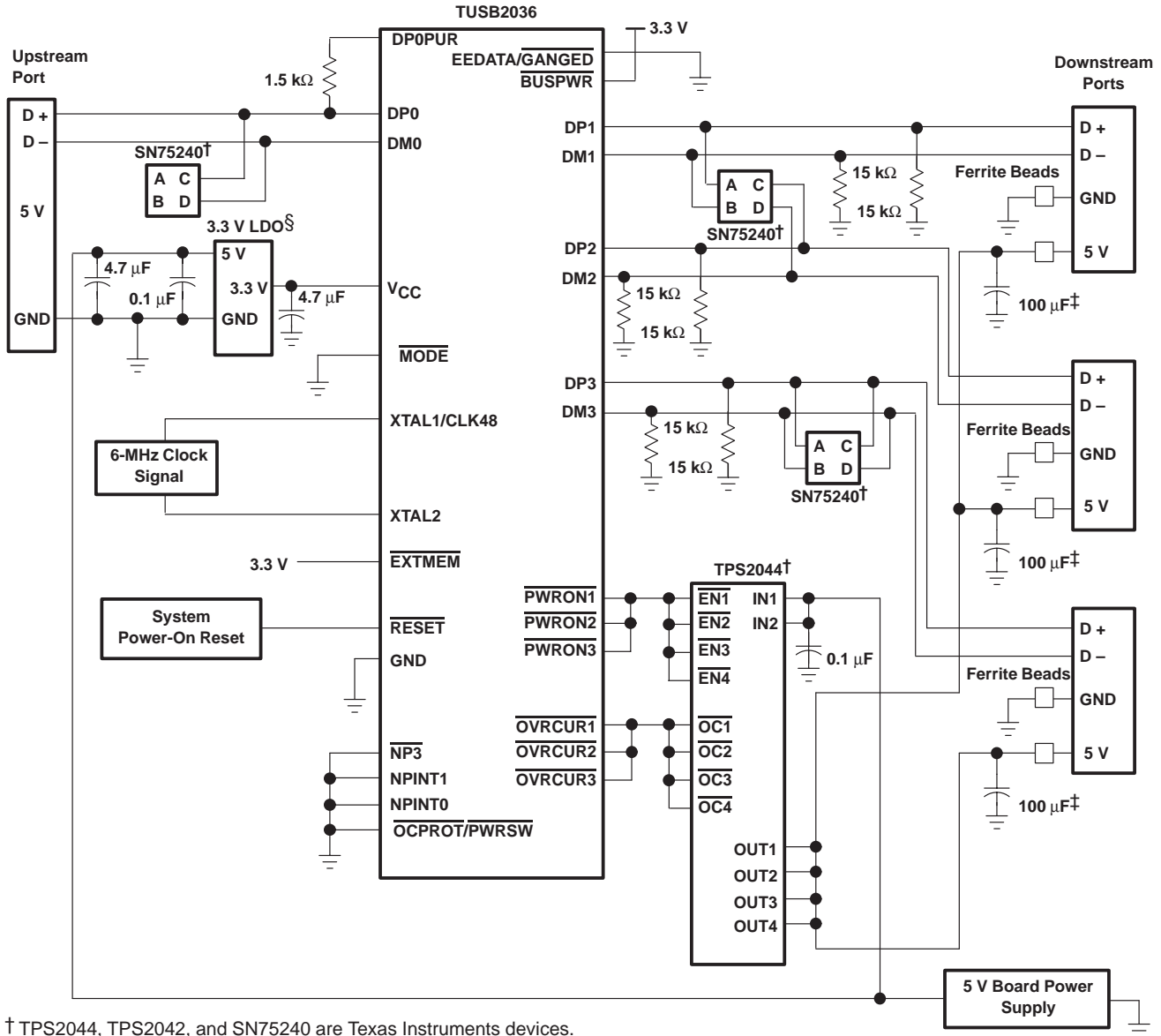

† TPS2044, TPS2042, and SN75240 are Texas Instruments devices.

The TPS2024 can be substituted for the TPS2044.

‡ 120 µF per hub is the minimum required per the USB specification, version 1.1. However, TI recommends a 100 µF low ESR tantalum capacitor per port for immunity to voltage droop.

§ LDO is a 5 V to 3.3 V voltage regulator

Figure 11. TUSB2036 Self-Powered Hub, Ganged Port-Power Management Application

APPLICATION INFORMATION

self-powered hub, individual port-power management (continued)

In a self-powered configuration, the TUSB2036 can be implemented for individual port-power management when used with the TPS2044 because it is capable of supplying 500 mA of current to each downstream port and can provide current limiting on a per port basis. When the hub detects a fault on a downstream port, power is removed from only the port with the fault and the remaining ports continue to operate normally. Self-powered hubs are required to implement overcurrent protection and report overcurrent conditions. The SN75240 transient suppressors reduce inrush current and voltage spikes on the data lines.

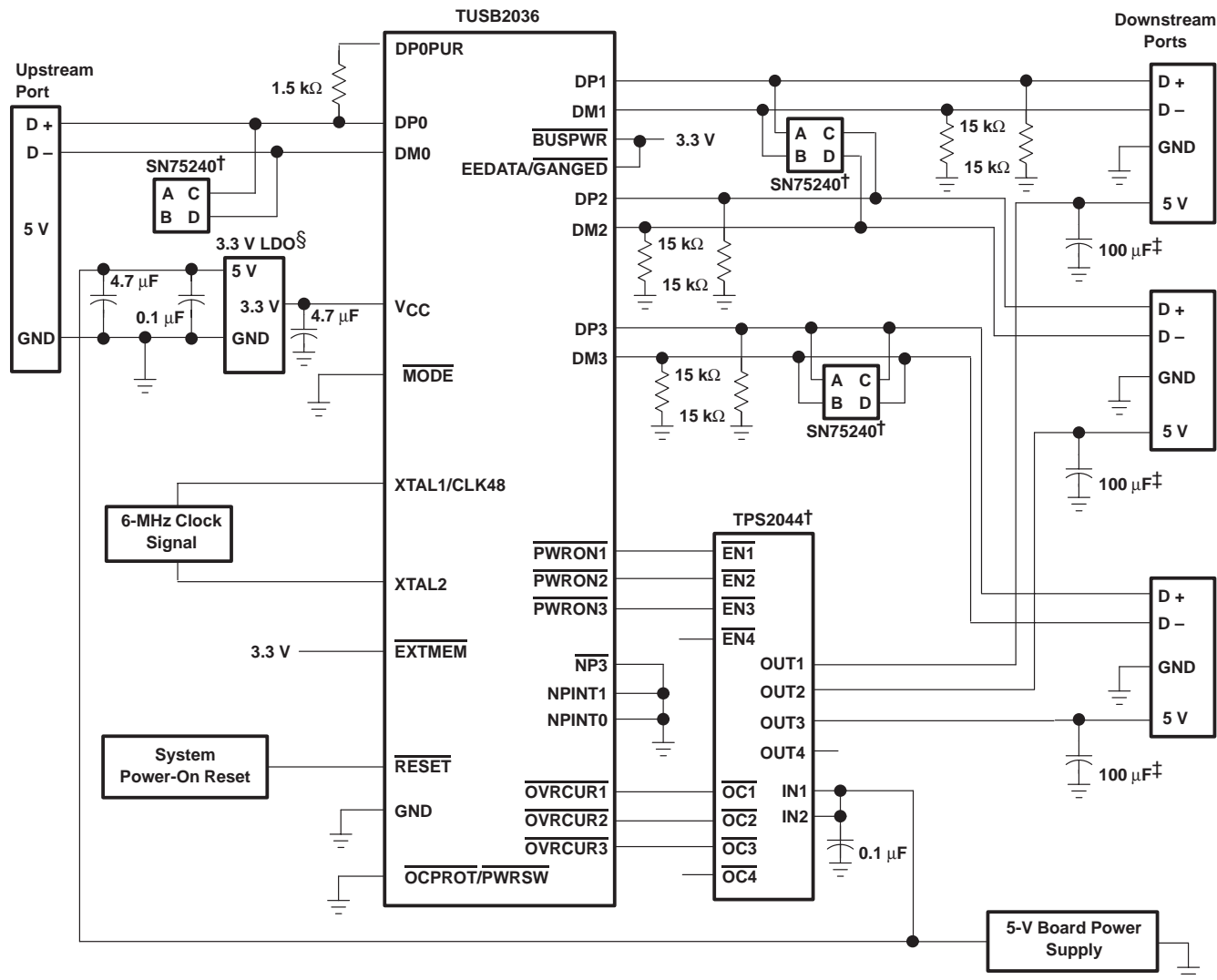

† TPS2042 and SN75240 are Texas Instruments devices. Two TPS2042 devices can be substituted for the TPS2044.

‡ 120 μ F per hub is the minimum required per the USB specification, version 1.1. However, TI recommends a 100 μ F low ESR tantalum capacitor per port for immunity to voltage droop.

§ LDO is a 5 V to 3.3 V voltage regulator

Figure 12. TUSB2036 Self-Powered Hub, Individual Port-Power Management Application

TUSB2036
2/3-PORT HUB FOR THE UNIVERSAL SERIAL BUS
WITH OPTIONAL SERIAL EEPROM INTERFACE

SLLS372 – MARCH 2000

MECHANICAL DATA

VF (S-PQFP-G32)

PLASTIC QUAD FLATPACK

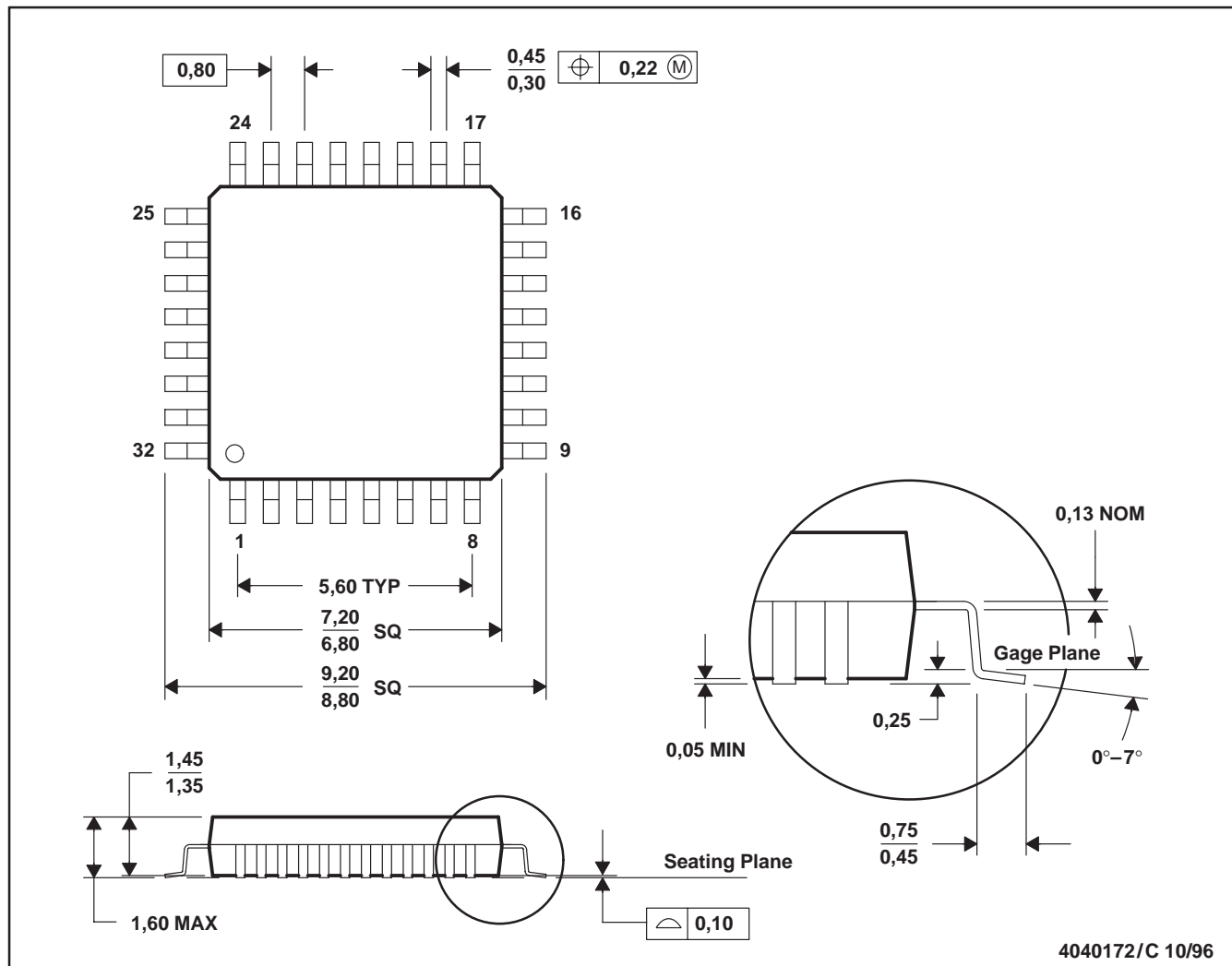

- NOTES: A. All linear dimensions are in millimeters.
 B. This drawing is subject to change without notice.
 C. Falls within JEDEC MS-026

(This page has been left blank intentionally.)

IMPORTANT NOTICE

Texas Instruments and its subsidiaries (TI) reserve the right to make changes to their products or to discontinue any product or service without notice, and advise customers to obtain the latest version of relevant information to verify, before placing orders, that information being relied on is current and complete. All products are sold subject to the terms and conditions of sale supplied at the time of order acknowledgement, including those pertaining to warranty, patent infringement, and limitation of liability.

TI warrants performance of its semiconductor products to the specifications applicable at the time of sale in accordance with TI's standard warranty. Testing and other quality control techniques are utilized to the extent TI deems necessary to support this warranty. Specific testing of all parameters of each device is not necessarily performed, except those mandated by government requirements.

CERTAIN APPLICATIONS USING SEMICONDUCTOR PRODUCTS MAY INVOLVE POTENTIAL RISKS OF DEATH, PERSONAL INJURY, OR SEVERE PROPERTY OR ENVIRONMENTAL DAMAGE ("CRITICAL APPLICATIONS"). TI SEMICONDUCTOR PRODUCTS ARE NOT DESIGNED, AUTHORIZED, OR WARRANTED TO BE SUITABLE FOR USE IN LIFE-SUPPORT DEVICES OR SYSTEMS OR OTHER CRITICAL APPLICATIONS. INCLUSION OF TI PRODUCTS IN SUCH APPLICATIONS IS UNDERSTOOD TO BE FULLY AT THE CUSTOMER'S RISK.

In order to minimize risks associated with the customer's applications, adequate design and operating safeguards must be provided by the customer to minimize inherent or procedural hazards.

TI assumes no liability for applications assistance or customer product design. TI does not warrant or represent that any license, either express or implied, is granted under any patent right, copyright, mask work right, or other intellectual property right of TI covering or relating to any combination, machine, or process in which such semiconductor products or services might be or are used. TI's publication of information regarding any third party's products or services does not constitute TI's approval, warranty or endorsement thereof.