

- Complete Power-Supply/Audio System For Cellular Handsets
- Three Low-Dropout Regulators (LDOs) with 100-mV Dropout
- Speaker and Ringer Power Amplifiers Drive 32-Ω Dynamic Speakers or Piezo Devices
- Low-Noise Microphone Amplifier
- Depop Protection For All Amplifiers
- Less Than 1 μA Supply Current in Shutdown, Typical
- 250-ms Microprocessor Reset Output
- 10-mA Charge-Pump Driver Configurable For Inverted or Doubled Output
- Separate Enables for LDOs, Amplifiers, and Charge Pump
- 1.185-V Reference Capable of Driving 2 mA
- 48-Pin TQFP Package

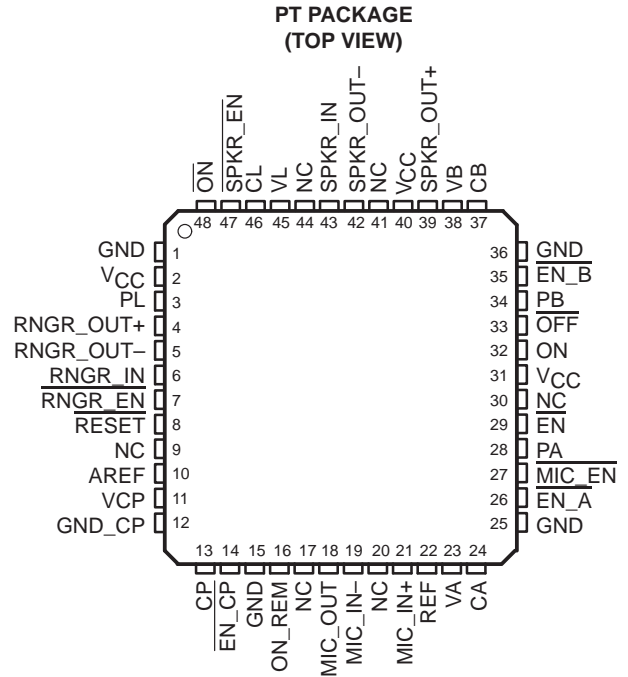

description

The TPS9104 incorporates a complete power supply and audio power system for a cellular subscriber terminal that uses battery packs with three or four NiMH/NiCd cells or a single lithium-ion cell. The device includes three low-dropout linear regulators rated for 3.3 V or 3 V at 100 mA each, a charge-pump driver, two power amplifiers for a speaker and a ringer, a low-noise microphone amplifier, and logic that includes a 250-ms reset, on/off control, and processor interface. Regulators A and B and the charge-pump driver are disabled until regulator L (logic regulator) reaches the rated voltage and $\overline{\text{RESET}}$ is logic high. Regulators A and B, the charge-pump driver, and the amplifiers have separate enables allowing circuitry to be powered up or down as necessary to conserve battery power.

Each of the amplifiers has a depop circuit to prevent objectionable noise when the IC is powered up or when the amplifiers are enabled. Both the speaker amplifier and the ringer amplifier are designed to supply 2 V peak-to-peak into 32 Ω or into a 90-nF piezoelectric speaker. The microphone amplifier is a low-noise high-gain ($A_V=100$) circuit capable of supplying 3 V peak-to-peak into a 10-kΩ load.

The TPS9104 operates over a free-air temperature range of -40°C to 85°C and is supplied in a 48-pin TQFP package.

AVAILABLE OPTIONS

T _A	PACKAGED DEVICE	CHIP FORM (Y)
	THIN QFP (PT)	
-40°C to 85°C	TPS9104IPT	TPS9104Y

The PT package is available taped and reeled. Add R suffix to the device type when ordering (e.g. TPS9104IPTR).



Please be aware that an important notice concerning availability, standard warranty, and use in critical applications of Texas Instruments semiconductor products and disclaimers thereto appears at the end of this data sheet.

PRODUCTION DATA information is current as of publication date. Products conform to specifications per the terms of Texas Instruments standard warranty. Production processing does not necessarily include testing of all parameters.

TPS9104 CELLULAR SUBSCRIBER TERMINAL POWER SUPPLY/AUDIO SYSTEM

SLVS133A – AUGUST 1996 – REVISED APRIL 1998

functional block diagram

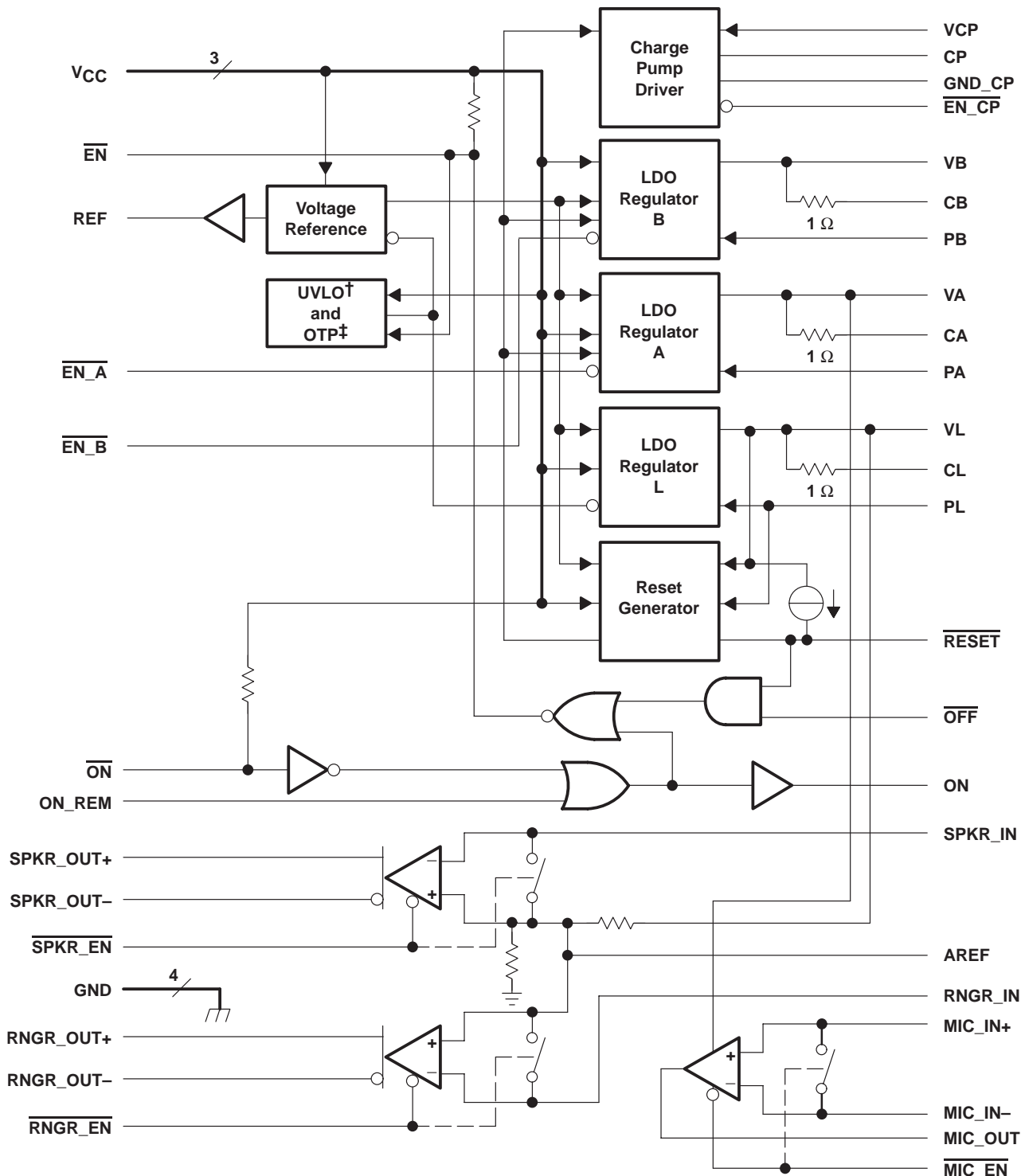

† UVLO - Undervoltage lockout
‡ OTP - Overtemperature protection

TPS9104Y chip information

These chips, when properly assembled, display characteristics similar to the TPS9104. Thermal compression or ultrasonic bonding may be used on the doped aluminum bonding pads. The chips may be mounted with conductive epoxy or a gold-silicon preform.

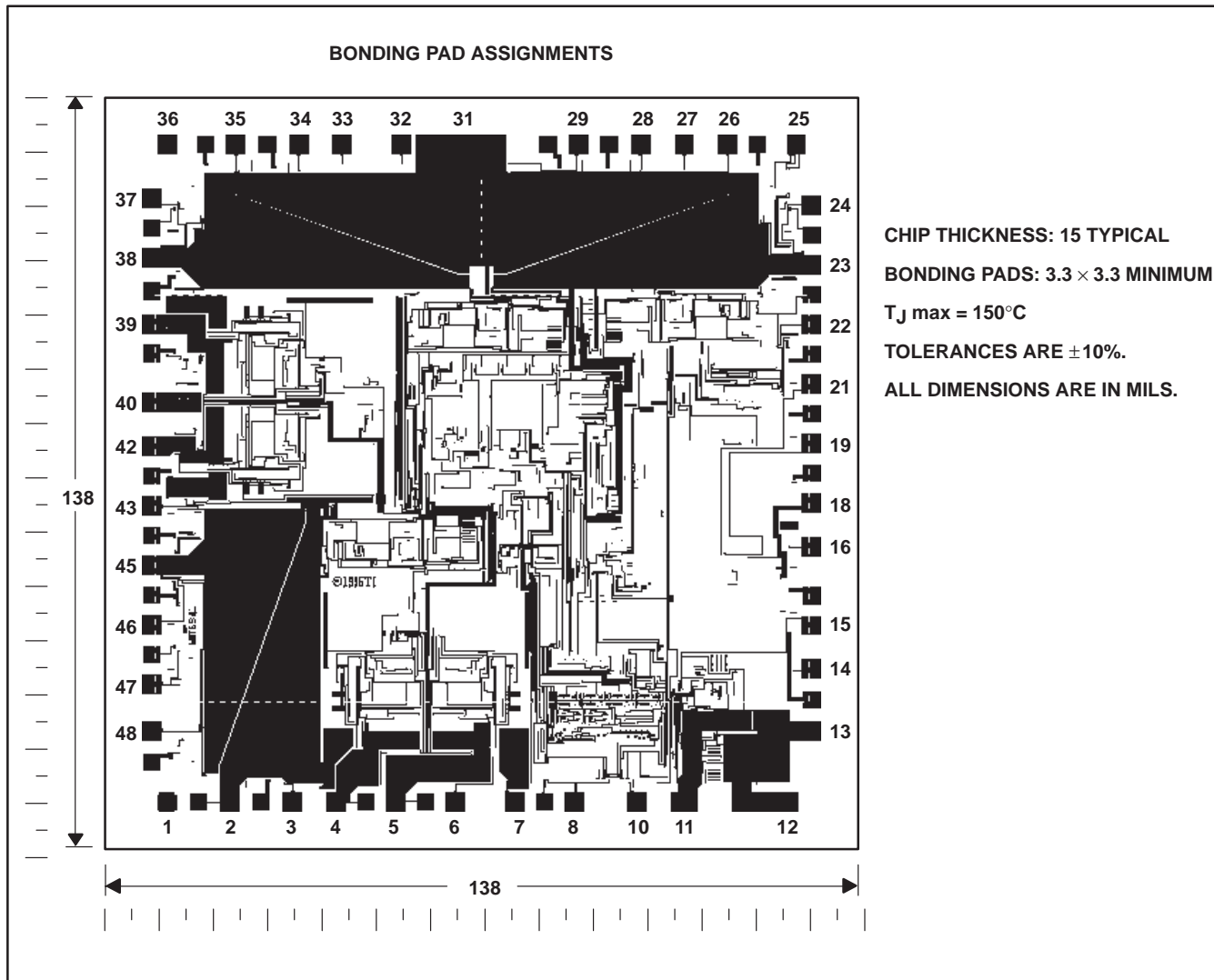

TPS9104
CELLULAR SUBSCRIBER TERMINAL
POWER SUPPLY/AUDIO SYSTEM

SLVS133A – AUGUST 1996 – REVISED APRIL 1998

Terminal Functions

TERMINAL NAME	NO.	I/O	DESCRIPTION
GND	1, 15, 25, 36		Ground. GND terminals should be externally connected to ground to ensure proper functionality.
V _{CC}	2, 31, 40		Supply voltage input. V _{CC} terminals are not connected internally and must be externally connected to ensure proper functionality.
PL	3	I	Program L. PL provides voltage programming input for regulator L.
RNGR_OUT+	4	O	Ringer amplifier noninverting output
RNGR_OUT-	5	O	Ringer amplifier inverting output
RNGR_IN	6	I	Ringer amplifier input
RNGR_EN	7	I	Ringer amplifier enable input; logic low enables the amplifier
RESET	8	O	Microprocessor reset output
NC	9, 17, 20, 30, 41, 44		No connection
AREF	10		Analog reference. A 0.1-μF capacitor must be connected from AREF to ground. No other connections are allowed.
VCP	11		Charge pump driver supply voltage
GND_CP	12		Charge pump driver ground
CP	13	O	Charge pump driver output
EN_CP	14	I	Charge pump driver enable input. Logic low on EN_CP turns on the charge pump.
ON_REM	16	I	Remote on; logic high enables the part.
MIC_OUT	18	O	Microphone amplifier output
MIC_IN-	19	I	Microphone amplifier inverting input
MIC_IN+	21	I	Microphone amplifier noninverting input
REF	22	O	1.185-V reference output. Decouple with 0.01-μF to 0.1-μF capacitor to ground.
VA	23	O	Regulator A output voltage
CA	24		Regulator A filter capacitor connection
EN_A	26	I	Regulator A enable input; logic low turns on the regulator.
MIC_EN	27	I	Microphone amplifier enable input; logic low turns on the microphone amplifier.
PA	28	I	Program A. PA provides programming input for Regulator A.
EN	29	I/O	Enable signal input/output; logic low enables the part.
ON	32	O	On-signal output
OFF	33	I	Off signal
PB	34	I	Program B. PB provides programming input for Regulator B.
EN_B	35	I	Regulator B enable input; logic low turns on the regulator.
CB	37		Regulator B filter capacitor connection
VB	38	O	Regulator B output voltage
SPKR_OUT+	39	O	Speaker amplifier noninverting output
SPKR_OUT-	42	O	Speaker amplifier inverting output
SPKR_IN	43	I	Speaker amplifier input
VL	45	O	Regulator L output voltage
CL	46		Regulator L filter capacitor connection
SPKR_EN	47	I	Speaker amplifier enable input; logic low enables the amplifier.
ON	48	I	On signal; logic low enables the part.



detailed description

voltage reference

The regulators and reset generator utilize an internal 1.185-V band-gap voltage reference. The reference is also buffered and brought out on REF for external use; REF can source a maximum of 2 mA. A 0.01- μ F to 0.1- μ F capacitor must be connected between REF and ground.

LDO regulators

The TPS 9104 includes three low-dropout regulators, implemented with 1- Ω PMOS series-pass transistors, with quiescent supply currents of 100 μ A. Each of the regulators can supply up to 100 mA of continuous output current. The 1- Ω PMOS series-pass transistor achieves the dropout voltage of just 100 mV at the maximum rated output current. Each regulator output voltage can be independently programmed to either 3.3 V or 3 V using its programming control input PL, PA or PB (Px). A logic low on Px sets the output voltage of the regulator to 3.3 V; a logic high sets it to 3 V.

Each LDO contains a current limit circuit. When the current demand on the regulator exceeds the current limit, the output voltage drops in proportion to the excess current. When the excess load current is removed, the output voltage returns to regulation. Exceeding the current limit on VL can disable the TPS9104. If enough current demand is placed on VL, the output voltage drops below the reset threshold voltage causing $\overline{\text{RESET}}$ to go low, effectively unlatching the enable.

VL is intended to be the primary supply voltage for the microprocessor and other system logic functions. VA and VB can be used to power low-noise analog circuits and/or implement system power management. The enable terminals $\overline{\text{EN}}_A$ and $\overline{\text{EN}}_B$ are utilized to power down circuitry when it is not required. $\overline{\text{EN}}_A$ and $\overline{\text{EN}}_B$ are TTL-compatible inputs with 10- μ A active current-source pullups. A logic low enables the respective regulator while a logic high pulls the regulator output voltage to ground and reduces the regulator quiescent current to leakage levels. Both $\overline{\text{EN}}_A$ and $\overline{\text{EN}}_B$ are not active until $\overline{\text{RESET}}$ is logic high.

Stability of the LDOs is ensured by the addition of compensation terminals CL, CA, and CB, which connect to the output of the regulator through an internal 1- Ω resistor. This compensation scheme allows for capacitors with equivalent series resistance (ESR) of up to 15 Ω , eliminating the need for expensive, low-ESR capacitors.

reset generator

$\overline{\text{RESET}}$ is a microprocessor reset signal that goes to logic low at power-up, or whenever VL drops below 2.93 V (2.6 V for 3-V applications), and remains in that state for 250 ms after VL exceeds the $\overline{\text{RESET}}$ threshold (see Figure 5). The open-drain output has a 30- μ A pullup that eliminates the need for an external pullup resistor and still allows it to be connected with other open-drain or open-collector signals. $\overline{\text{RESET}}$ is valid for supply voltages as low as 1.5 V.

$\overline{\text{ON}}$, $\overline{\text{OFF}}$, ON, ON_REM and $\overline{\text{EN}}$ functions

The $\overline{\text{ON}}$ input is intended to be the main enable for the TPS9104 and should be connected to ground through a push-button switch. Once the switch is pressed, internal logic pulls $\overline{\text{EN}}$ low. The $\overline{\text{EN}}$ terminal is designed to sink 3.2 mA and can be used as a pull-down to enable other functions on the TPS9104 or other system circuitry. When $\overline{\text{EN}}$ is pulled low, the TPS9104 checks to make sure the supply voltage is above the UVLO threshold voltage and the die temperature is below 160°C. If both of these conditions are met, the reference circuitry, regulator L, reset generator, and other support circuitry are enabled. When $\overline{\text{RESET}}$ goes high, the system can respond with a logic high on $\overline{\text{OFF}}$, which latches the TPS9104 on, and the $\overline{\text{ON}}$ push button can then be released.

The TPS9104 is disabled in a similar manner. If the $\overline{\text{ON}}$ push button is pressed while the TPS9104 is enabled, the ON signal responds with a logic high. Once this logic high is detected, the system can respond with a logic low on $\overline{\text{OFF}}$, disabling the TPS9104 and reducing supply currents to 1 μ A (see Figure 1).

TPS9104 CELLULAR SUBSCRIBER TERMINAL POWER SUPPLY/AUDIO SYSTEM

SLVS133A – AUGUST 1996 – REVISED APRIL 1998

The ON_REM signal can be used in the same manner as \overline{ON} in enabling or disabling the TPS9104. The signal is provided as a system interface to increase the flexibility of the system. \overline{EN} can also be used as an input wired-OR open collector/drain to enable the TPS9104; however, it does not produce a logic signal ON and therefore cannot be used in the disable sequence described above. It is not recommended that \overline{EN} be used as the primary enable signal for the TPS9104.

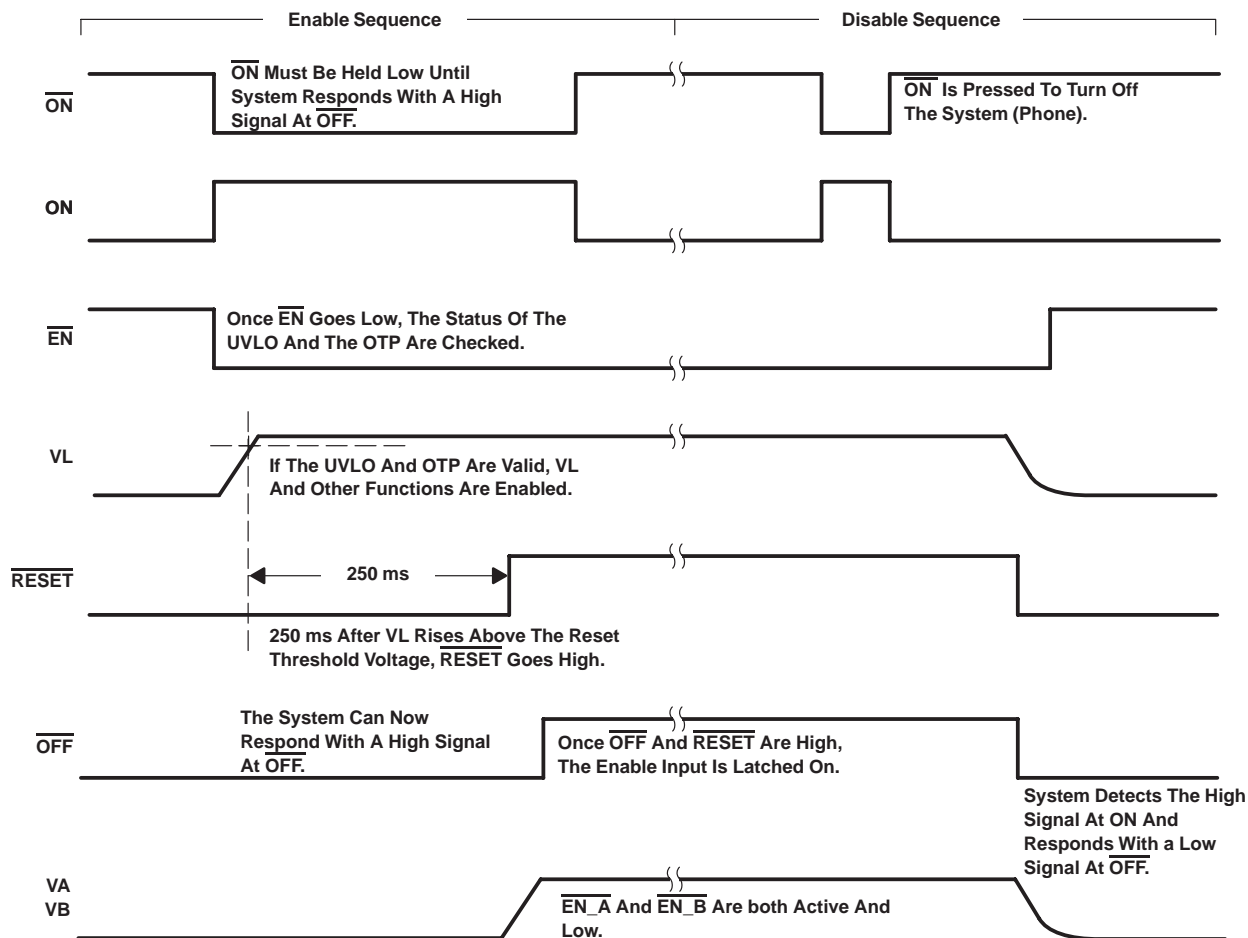

Figure 1. Recommended Enable and Disable Sequence

speaker/ringer power amplifiers

The TPS9104 includes two differential-output power amplifiers capable of driving dynamic or piezoelectric speakers. Both amplifiers have enable inputs to reduce supply current to leakage levels when the amplifiers are not in use. Depopping circuitry prevents objectionable noise when the enable inputs are cycled on or off. Each amplifier requires only two gain-setting resistors and a capacitor for dc blocking (see Figure 46). $\overline{RNGR_EN}$ and $\overline{SPKR_EN}$ inputs are disabled when \overline{RESET} is asserted. Both the $\overline{SPKR_EN}$ and the $\overline{RNGR_EN}$ have internal 10- μ A pullups.

microphone amplifier

This is a high-gain amplifier capable of driving a 10-k Ω load at 3 V peak-to-peak output. $\overline{MIC_EN}$ input is disabled when \overline{RESET} is asserted. The microphone amplifier has an enable input that reduces supply current to leakage levels when disabled. Added depopping circuitry prevents objectionable noise when the enable input

is cycled on or off. The microphone amplifier needs only two resistors to set the gain, and one capacitor for dc blocking (see Figure 47). Regulator A is the analog supply for the microphone amplifier, and $\overline{\text{EN_A}}$ must be asserted for correct operation.

undervoltage lockout

Undervoltage lockout (UVLO) prevents operation of the functions in the TPS9104 until the supply voltage exceeds the threshold voltage, eliminating abnormal power-up conditions internally and externally, and providing an orderly turn-on.

overtemperature shutdown

If the die temperature exceeds 160°C, the thermal protection circuit shuts off the TPS9104. When the die temperature drops below 150°C, the device can be restarted with the $\overline{\text{ON}}$ input.

charge pump driver

An unregulated inverting or doubler charge pump is implemented (see Figure 44) by connecting a network of two capacitors and two diodes to CP. In the inverting configuration, the charge pump can power an LCD or provide gate bias for a GaAs power amplifier. A 5-V supply for flash-memory programming or powering the subscriber identity module (SIM) European applications can be achieved using the doubler configuration and an external LDO. A logic-low input to the charge-pump enable, $\overline{\text{EN_CP}}$, turns on the oscillator and driver; a logic high turns them off. $\overline{\text{EN_CP}}$ input is disabled when $\overline{\text{RESET}}$ is asserted. The $\overline{\text{EN_CP}}$ has a 10- μA internal pullup.

DISSIPATION RATING TABLE 1 – Free-Air Temperature

PACKAGE	$T_A \leq 25^\circ\text{C}$ POWER RATING	DERATING FACTOR ABOVE $T_A = 25^\circ\text{C}$	$T_A = 70^\circ\text{C}$ POWER RATING	$T_A = 85^\circ\text{C}$ POWER RATING
PT	1350 mW	10.8 mW/°C	864 mW	702 mW

DISSIPATION RATING TABLE 2 – Case Temperature

PACKAGE	$T_C \leq 25^\circ\text{C}$ POWER RATING	DERATING FACTOR ABOVE $T_C = 25^\circ\text{C}$	$T_C = 70^\circ\text{C}$ POWER RATING	$T_C = 85^\circ\text{C}$ POWER RATING
PT	6579 mW	52.6 mW/°C	4212 mW	3423 mW

TPS9104
CELLULAR SUBSCRIBER TERMINAL
POWER SUPPLY/AUDIO SYSTEM

SLVS133A – AUGUST 1996 – REVISED APRIL 1998

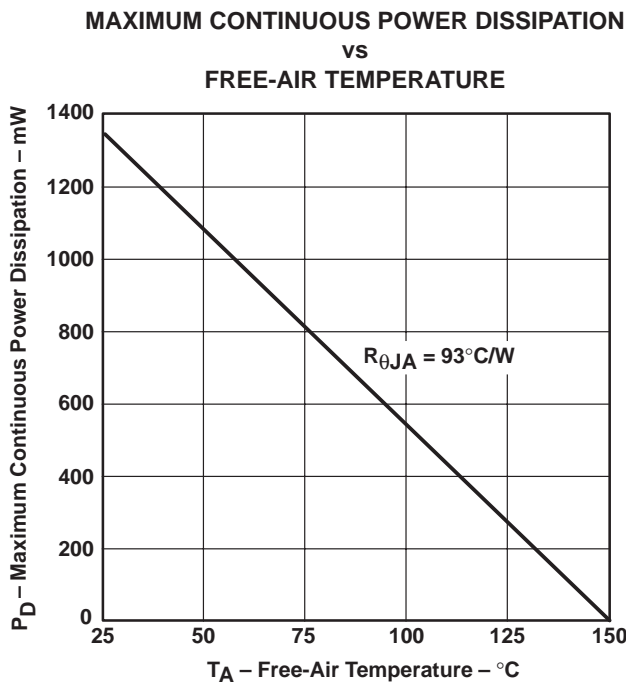

Figure 2

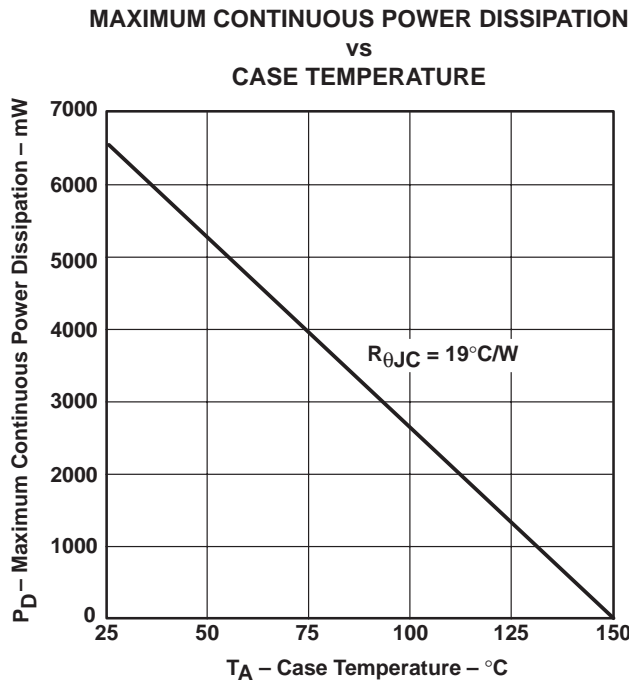

Figure 3

absolute maximum ratings over operating free-air temperature range (unless otherwise noted)†‡

Supply voltage range, V _{CC} , V _{CP}	-0.3 V to 12 V
Input voltage range at OFF, MIC_EN, SPKR_EN, RNGR_EN, SPKR_IN, RNGR_IN, MIC_IN+, MIC_IN-	-0.3 V to 7 V
Input voltage range at PL, PA, PB, EN, EN_A, EN_B, ON, ON_REM, EN_CP	-0.3 V to V _{CC}
Continuous total power dissipation	See dissipation rating table
Peak output current	Internally limited
Output current range at SPKR_OUT+, SPKR_OUT-, RNGR_OUT+, RNGR_OUT-	-100 mA to 100 mA
Power dissipation	See dissipation rating table
Operating free-air temperature range, T _A	-40°C to 85°C
Storage temperature range, T _{stg}	-65°C to 150°C
Lead Temperature 1,6 mm (1/16 inch) from case for 10 seconds	260°C

† Stresses beyond those listed under “absolute maximum ratings” may cause permanent damage to the device. These are stress ratings only, and functional operation of the device at these or any other conditions beyond those indicated under “recommended operating conditions” is not implied. Exposure to absolute-maximum-rated conditions for extended periods may affect device reliability.

‡ All voltages are with respect to GND.



recommended operating conditions

	MIN	NOM	MAX	UNIT
Supply voltage, V_{CC} , V_{CP}	3		10	V
Input voltage, \overline{OFF} , $\overline{MIC_EN}$, $\overline{SPKR_EN}$, $\overline{RNGR_EN}$	0		5	V
Input voltage at PL, PA, PB, \overline{EN} , $\overline{EN_A}$, $\overline{EN_B}$, \overline{ON} , $\overline{ON_REM}$, $\overline{EN_CP}$	0		V_{CC}	V
Reference output current	0		2	mA
Continuous regulator output current	0		100	mA
Operating free-air temperature	-40		85	°C

**electrical characteristics over recommended operating free-air temperature range,
 $V_{CC} = V_{CP} = 4\text{ V}$, $P_x = 0\text{ V}$, $I_{O(V_x)} = 35\text{ mA}$, $\overline{OFF} = \text{VL}$, \overline{ON} open, $\overline{ON_REM} = 0\text{ V}$, $C_x = 10\text{ }\mu\text{F}$
 (unless otherwise noted)**

voltage reference (REF)						
PARAMETER	TEST CONDITIONS†		MIN	TYP	MAX	UNIT
Output voltage	$T_A = 25^\circ\text{C}$,	$I_O = 0$		1.185		V
	$4\text{ V} \leq V_{CC} \leq 10\text{ V}$,	$0 \leq I_O \leq 2\text{ mA}$	1.161		1.209	V
LDO regulators						
PARAMETER	TEST CONDITIONS†		MIN	TYP	MAX	UNIT
Output voltage at VA, VB, VL (V_x)	$T_A = 25^\circ\text{C}$		3.25	3.3	3.35	V
	$0 \leq I_{O(V_x)} \leq 100\text{ mA}$,	$3.5\text{ V} \leq V_{CC} \leq 10\text{ V}$	3.2		3.4	V
	$P_x = V_{CC}$,	$T_A = 25^\circ\text{C}$	2.95	3	3.05	V
	$P_x = V_{CC}$,	$0 \leq I_{O(V_x)} \leq 100\text{ mA}$,	2.9		3.10	V
	$3.2\text{ V} \leq V_{CC} \leq 10\text{ V}$					
Dropout voltage	$I_{O(V_x)} = 100\text{ mA}$,	$V_{CC} = 3.2\text{ V}$		100	200	mV
Load regulation	$I_{O(V_x)} = 0\text{ mA}$ to 100 mA			30		mV
Line regulation	$I_{O(V_x)} = 100\text{ mA}$,	$V_{CC} = 3.5\text{ V}$ to 10 V		10		mV
Ripple rejection	$f = 120\text{ Hz}$			60		dB
Quiescent current (each regulator)				100		μA
charge pump driver						
PARAMETER	TEST CONDITIONS		MIN	TYP	MAX	UNIT
Frequency			50	100	150	kHz
Duty cycle				50%		
Output resistance				15	30	Ω

† Pulse-testing techniques are used to maintain virtual junction temperature as close as possible to ambient temperature; thermal effect must be taken into account separately.

TPS9104
CELLULAR SUBSCRIBER TERMINAL
POWER SUPPLY/AUDIO SYSTEM

SLVS133A – AUGUST 1996 – REVISED APRIL 1998

electrical characteristics over recommended operating free-air temperature range,
 $V_{CC} = V_{CP} = 4\text{ V}$, $P_x = 0\text{ V}$, $I_{O(V_x)} = 35\text{ mA}$, **OFF = VL, **ON** open, **ON_REM** = 0 V, $C_x = 10\text{ }\mu\text{F}$**
(unless otherwise noted) (continued)

speaker amplifier/ringer amplifier						
PARAMETER	TEST CONDITIONS†	MIN	TYP	MAX	UNIT	
Output voltage swing	Single-ended, $R_L = 32\text{ }\Omega$	1.6	2		V	
Output offset voltage	$A_V = 1\text{ V/V}$		15	30	mV	
Total harmonic distortion (THD)	$V_{I(PP)} = 1\text{ V}$, $A_V = 1\text{ V/V}$, $f = 1\text{ kHz}$, $R_L = 32\text{ }\Omega$		0.5%	1%		
Gain bandwidth product (GBW)	$A_V = 10\text{ V/V}$	4	20		kHz	
Input noise	$100\text{ Hz} \leq \text{BW} \leq 100\text{ kHz}$		200		μVrms	
Quiescent current (each amplifier)			2		mA	
Reference voltage, AREF	$PL = V_{CC}$		1.221		V	
	$PL = 0\text{ V}$		1.345			
microphone amplifier						
PARAMETER	TEST CONDITIONS†	MIN	TYP	MAX	UNIT	
Common mode input voltage range		1		$V_A - 1$	V	
Input bias current	Both inputs = $V_A/2$	-1		1	μA	
Output voltage swing	10 k Ω load, $V_A = 3.3\text{ V}$	2.7	3		V	
Output offset voltage	$A_V = 1\text{ V/V}$			6	mV	
Total harmonic distortion (THD)	$f = 1\text{ kHz}$, $A_V = 100\text{ V/V}$, Output voltage swing = 1 V, $V_{O(PP)}$		0.5%	1%		
Power-supply rejection ratio (PSRR)	$A_V = 100\text{ V/V}$		100		dB	
Common-mode rejection ratio (CMRR)	$A_V = 100\text{ V/V}$		80		dB	
Gain bandwidth product (GBW)	$A_V = 100\text{ V/V}$	4			kHz	
Input noise	$100\text{ Hz} \leq \text{BW} \leq 100\text{ kHz}$		10		μVrms	
Quiescent current			180		μA	
RESET						
PARAMETER	TEST CONDITIONS†	MIN	TYP	MAX	UNIT	
Input threshold voltage	VL voltage decreasing	2.871	2.93	2.989	V	
Input threshold voltage	VL voltage decreasing, $PL = V_{CC}$	2.548	2.6	2.652	V	
Timeout delay at RESET	See Figure 5	125	250	375	ms	
Low-level output voltage	$I_O = 1\text{ mA}$, $V_{CC} = 1.5\text{ V}$			0.4	V	
High-level output current	$V_O = 2.4\text{ V}$	-40		-20	μA	
Low-level output current	$V_O = 0.4\text{ V}$			3.2	mA	
Hysteresis			40		mV	
logic inputs at EN_A , EN_B , SPKR_EN , RNGR_EN , MIC_EN , EN_CP						
PARAMETER	TEST CONDITIONS	MIN	TYP	MAX	UNIT	
High-level input voltage		2			V	
Low-level input voltage				0.8	V	
Input current		-20	-10	1	μA	

† Pulse-testing techniques are used to maintain virtual junction temperature as close as possible to ambient temperature; thermal effect must be taken into account separately.



electrical characteristics over recommended operating free-air temperature range,
 $V_{CC} = V_{CP} = 4\text{ V}$, $P_x = 0\text{ V}$, $I_{O(V_x)} = 35\text{ mA}$, $\overline{\text{OFF}} = \text{VL}$, $\overline{\text{ON}}$ open, $\text{ON_REM} = 0\text{ V}$, $C_x = 10\text{ }\mu\text{F}$
(unless otherwise noted) (continued)

logic inputs at PL, PA, PB, $\overline{\text{OFF}}$, ON_REM						
PARAMETER	TEST CONDITIONS	MIN	TYP	MAX	UNIT	
High-level input voltage		2			V	
Low-level input voltage				0.8	V	
Input current		-1		1	μA	
logic inputs at $\overline{\text{ON}}^\dagger$						
PARAMETER	TEST CONDITIONS	MIN	TYP	MAX	UNIT	
High-level input voltage		2			V	
Low-level input voltage				0.8	V	
Input current		-20		1	μA	
logic inputs at $\overline{\text{EN}}^\dagger$						
PARAMETER	TEST CONDITIONS	MIN	TYP	MAX	UNIT	
High-level input voltage		2.4			V	
Low-level input voltage				0.8	V	
Source current	$V_O = 2.4\text{ V}$ $\overline{\text{OFF}} = 0$	-50	-30	1	μA	
Sink current	$V_O = 0.4\text{ V}$			3.2	mA	
logic outputs at ON						
PARAMETER	TEST CONDITIONS	MIN	TYP	MAX	UNIT	
High-level output voltage	1-mA source current	2.4			V	
Low-level output voltage	1-mA sink current			0.4	V	
overtemperature shutdown						
PARAMETER	TEST CONDITIONS	MIN	TYP	MAX	UNIT	
Temperature threshold			160		$^\circ\text{C}$	
Temperature hysteresis			10		$^\circ\text{C}$	
undervoltage lockout (UVLO)						
PARAMETER	TEST CONDITIONS	MIN	TYP	MAX	UNIT	
Threshold	V_{CC} increasing	1.80		2.52	V	
Hysteresis			50		mV	
supply current						
PARAMETER	TEST CONDITIONS	MIN	TYP	MAX	UNIT	
Shutdown	$\overline{\text{OFF}} = 0\text{ V}$		0.5	10	μA	
Operating	$\overline{\text{EN_CP}} = \text{VCP}$, $\overline{\text{SPKR_EN}} = \text{VL}$, $\overline{\text{RNGR_EN}} = \text{VL}$, $\overline{\text{MIC_EN}} = \text{VL}$		0.7	1	mA	

† High and low level voltages are dependent on V_{CC} . See graphs.

TPS9104
CELLULAR SUBSCRIBER TERMINAL
POWER SUPPLY/AUDIO SYSTEM

SLVS133A – AUGUST 1996 – REVISED APRIL 1998

TPS9104Y electrical characteristics, $T_J = 25^\circ\text{C}$, $V_{CC} = V_{CP} = 4\text{ V}$, $P_x = 0\text{ V}$, $I_O(V_x) = 35\text{ mA}$, OFF = VL, ON open, ON_REM = 0 V, $C_x = 10\text{ }\mu\text{F}$ (unless otherwise noted)

voltage reference (REF)						
PARAMETER	TEST CONDITIONS†	MIN	TYP	MAX	UNIT	
Output voltage	$I_O = 0$		1.185		V	
LDO Regulators						
PARAMETER	TEST CONDITIONS†	MIN	TYP	MAX	UNIT	
Output voltage at VA, VB, VL (Vx)	$P_x = V_{CC}$	2.95	3	3.05	V	
Dropout voltage	$I_O(V_x) = 100\text{ mA}$, $V_{CC} = 3.2\text{ V}$		100		mV	
Load regulation	$I_O(V_x) = 0\text{ mA to }100\text{ mA}$		30		mV	
Line regulation	$I_O(V_x) = 100\text{ mA}$, $V_{CC} = 3.5\text{ V to }10\text{ V}$		10		mV	
Ripple rejection	$f = 120\text{ Hz}$		60		dB	
Quiescent current (each regulator)			100		μA	
charge pump driver						
PARAMETER	TEST CONDITIONS	MIN	TYP	MAX	UNIT	
Frequency			100		kHz	
Duty cycle			50%			
Output resistance			15		Ω	
speaker amplifier/ringer amplifier						
PARAMETER	TEST CONDITIONS†	MIN	TYP	MAX	UNIT	
Output voltage swing	Single-ended, $R_L = 32\text{ }\Omega$		2		V	
Output offset voltage	$A_v = 1\text{ V/V}$		15		mV	
Total harmonic distortion (THD)	$V_I(\text{PP}) = 1\text{ V}$, $A_v = 1\text{ V/V}$, $f = 1\text{ kHz}$, $R_L = 32\text{ }\Omega$		0.5%			
Gain bandwidth product (GBW)	$A_v = 10\text{ V/V}$		20		kHz	
Input noise	$100\text{ Hz} \leq \text{BW} \leq 100\text{ kHz}$		200		μVrms	
Quiescent current (each amplifier)			2		mA	
Reference, AREF	$PL = V_{CC}$		1.221		V	
	$PL = 0\text{ V}$		1.345			
microphone amplifier						
PARAMETER	TEST CONDITIONS†	MIN	TYP	MAX	UNIT	
Common mode input range		1		VA - 1	V	
Output voltage swing	10 k Ω load, $V_A = 3.3\text{ V}$	2.7	3		V	
Output offset voltage	$A_v = 1\text{ V/V}$			6	mV	
RESET						
PARAMETER	TEST CONDITIONS†	MIN	TYP	MAX	UNIT	
Threshold voltage	VL voltage decreasing		2.93		V	
Threshold voltage	VL voltage decreasing, $PL = V_{CC}$		2.6		V	
Delay	See Figure 5		250		ms	
Hysteresis			40		mV	

† Pulse-testing techniques are used to maintain virtual junction temperature as close as possible to ambient temperature; thermal effect must be taken into account separately.



PARAMETER MEASUREMENT INFORMATION

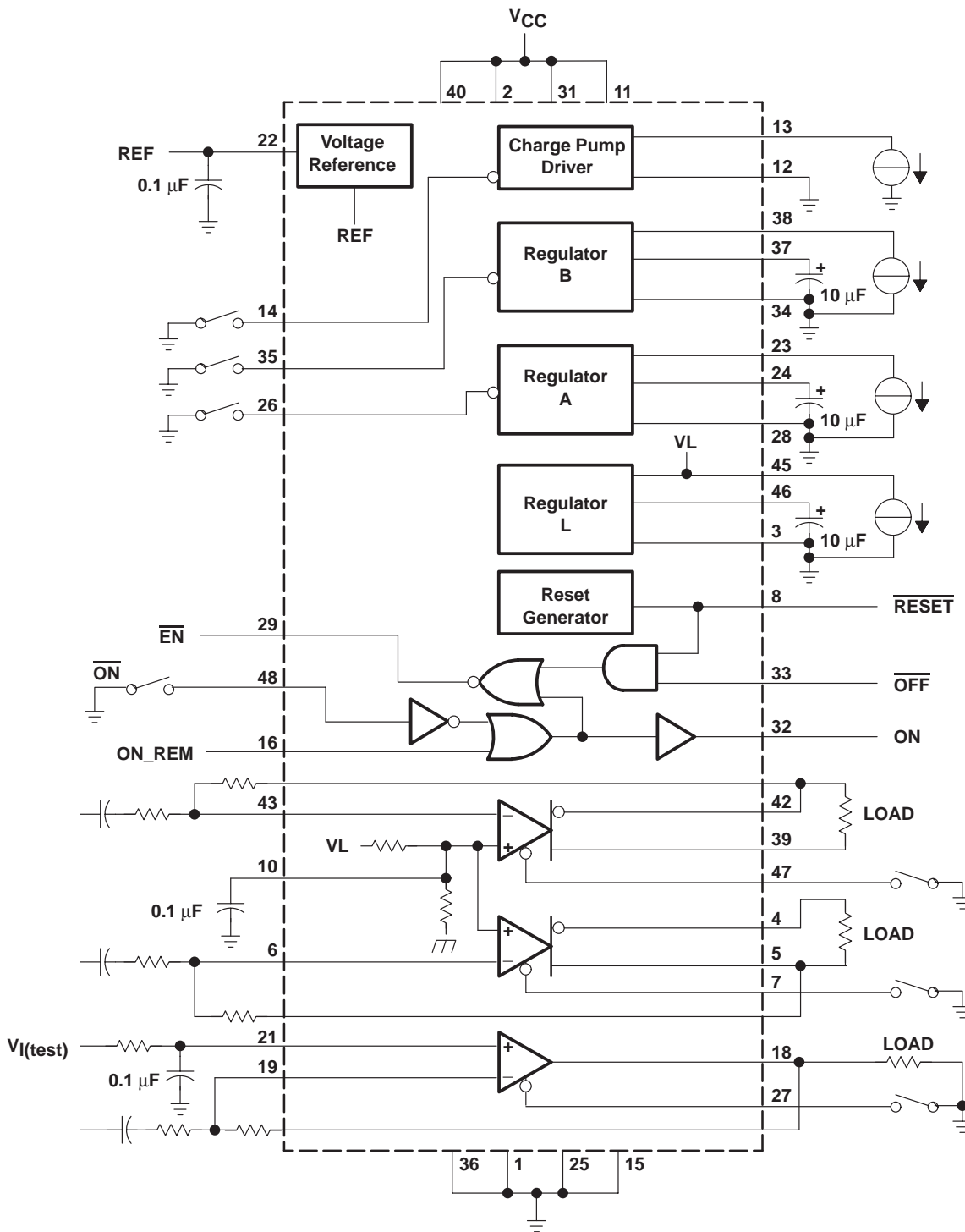

Figure 4. Test Circuit

PARAMETER MEASUREMENT INFORMATION

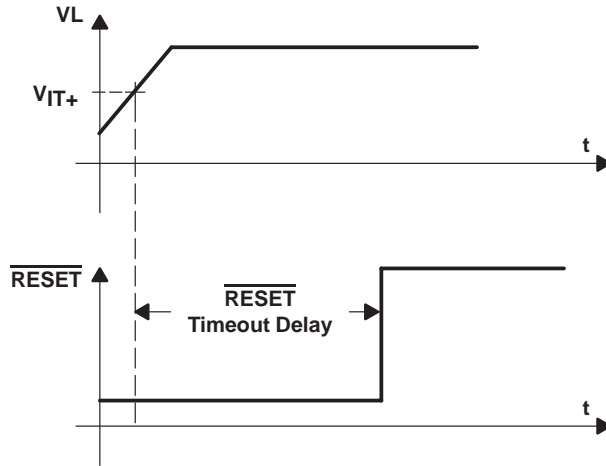

Figure 5. RESET Timing Diagram

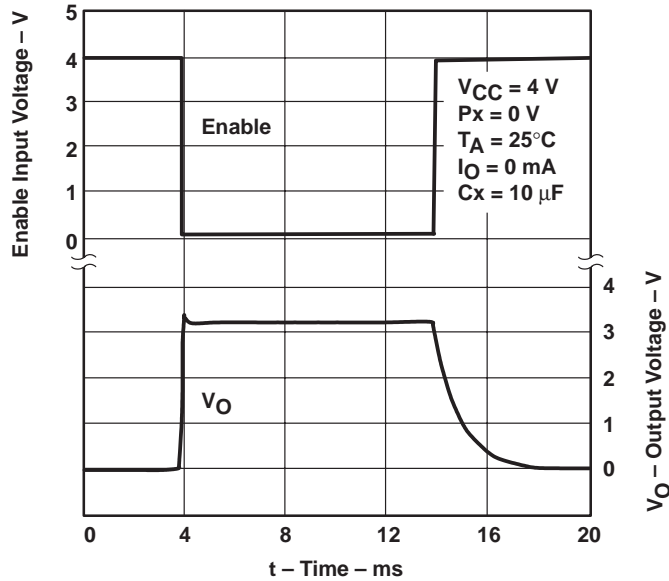

Figure 6. LDO Regulator Output Voltage Rise Time and Fall Time

PARAMETER MEASUREMENT INFORMATION

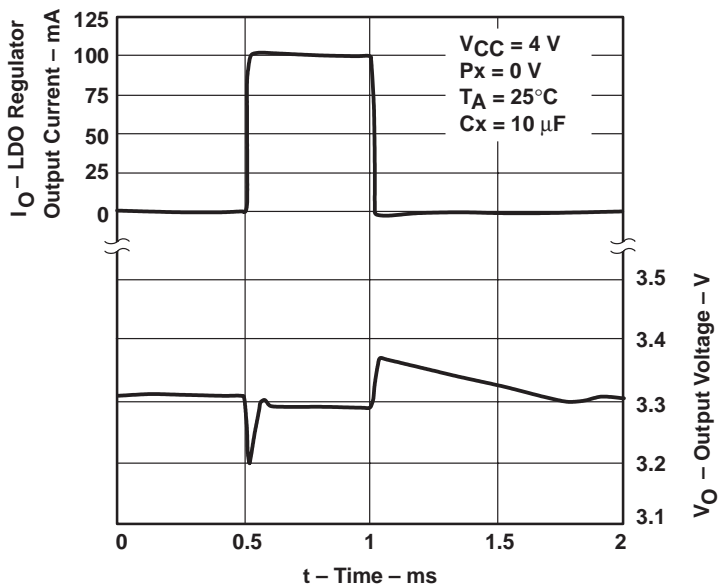

Figure 7. LDO Regulator Load Transient, 1 mA to 100 mA Pulsed Load

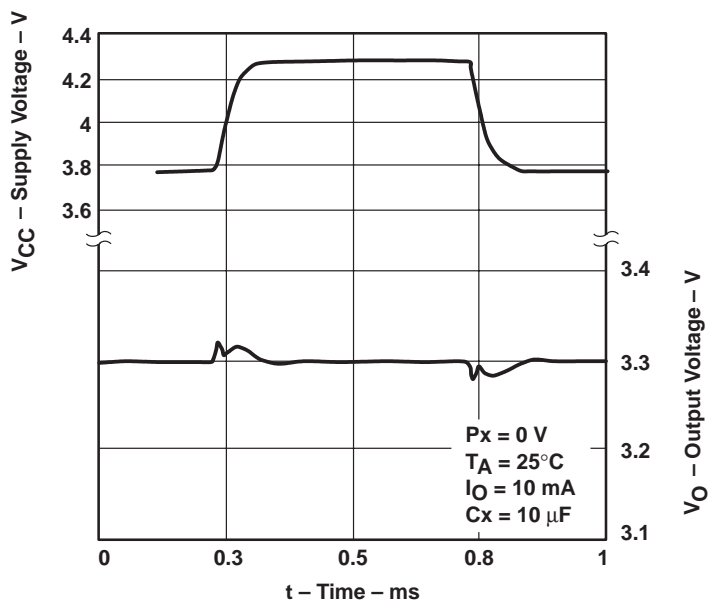

Figure 8. LDO Regulator Line Transient

PARAMETER MEASUREMENT INFORMATION

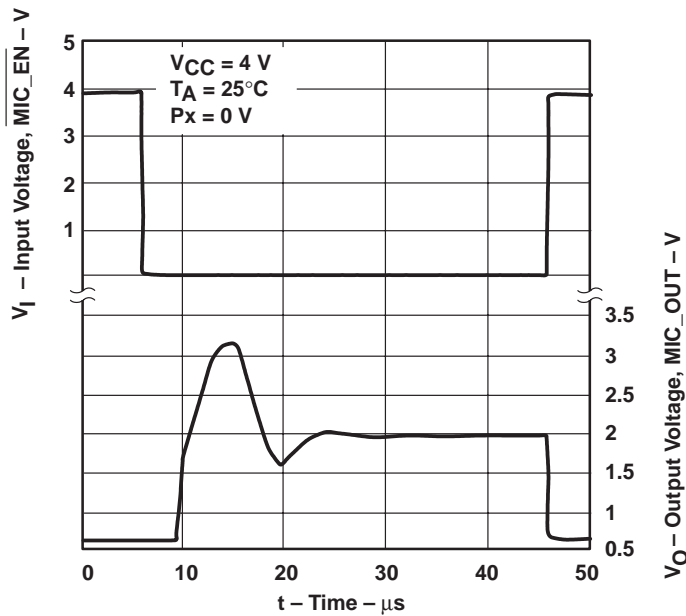

Figure 9. Microphone Enable Output Response

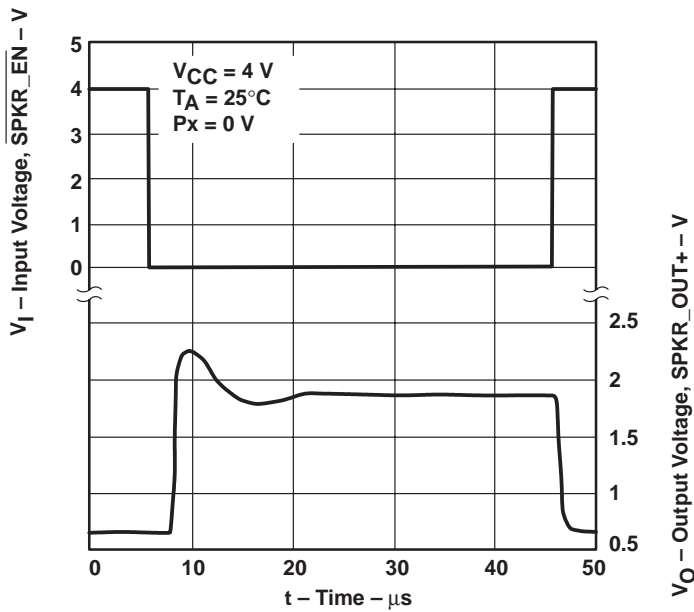

Figure 10. Speaker Enable Output Response

PARAMETER MEASUREMENT INFORMATION

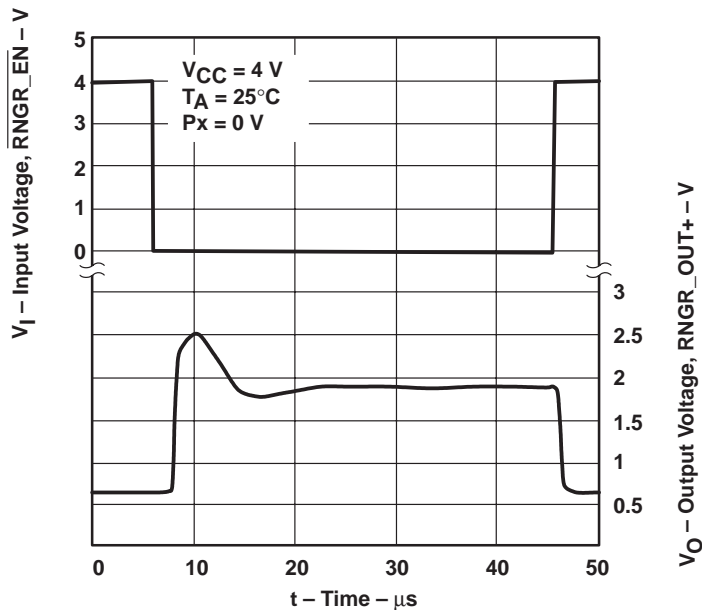

Figure 11. Ringer Enable Output Response

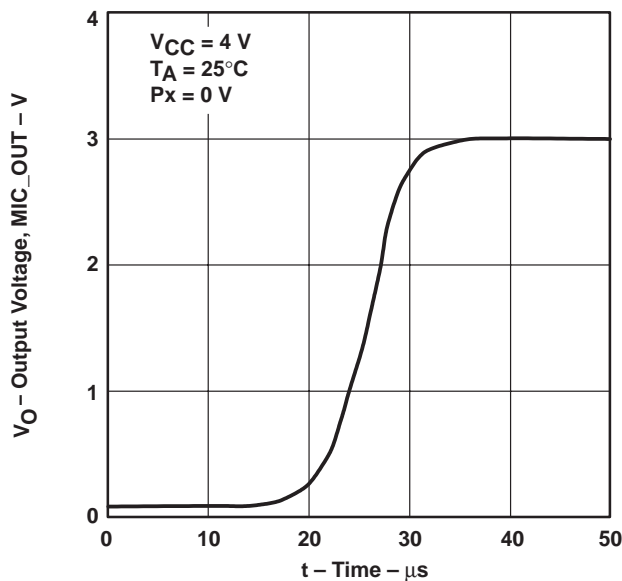

Figure 12. Microphone Slew Rate, Rising

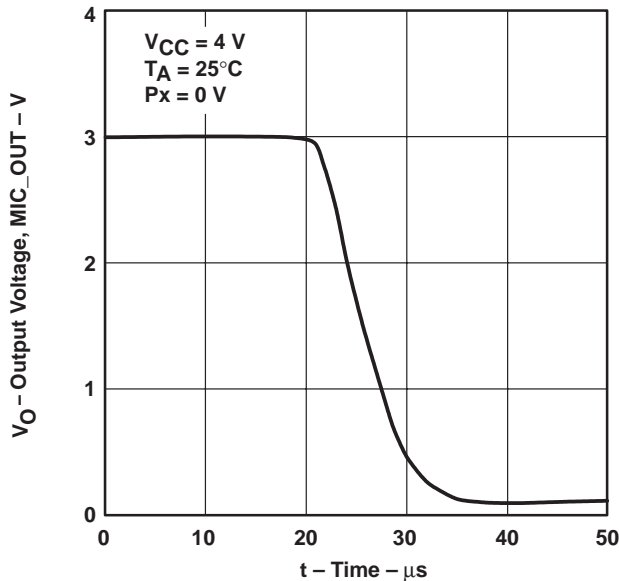

Figure 13. Microphone Slew Rate, Falling

TYPICAL CHARACTERISTICS

Table of Graphs

			FIGURE
I_{CC}	Quiescent current	vs Supply voltage	14
	Dropout voltage	vs Output current	15
		vs Junction temperature	16
ΔV_O	Change in output voltage	vs Junction temperature	17
V_O	Output voltage, VL	vs Supply voltage	18
ΔV_O	Change in output voltage	vs Supply voltage	19
ΔV_O	Change in output voltage	vs Output current	20
I_{CC}	Shutdown current	vs Supply voltage	21
	Threshold, \overline{ON}	vs Supply voltage	22
	Threshold, \overline{EN}	vs Supply voltage	23
	Threshold, ON_REM	vs Supply voltage	24
	Ripple rejection	vs Frequency	25
	Output spectral noise density	vs Frequency	26
	Change in frequency, CP	vs Junction temperature	27
r_O	Output resistance into CP	vs Supply voltage	28
r_O	Output resistance out of CP	vs Supply voltage	29
V_{OM}	Maximum peak output voltage	vs Load resistance	30
THD	Total harmonic distortion	vs Frequency	31
		vs Load resistance	32
k_{SVR}	Power supply rejection ratio	vs Frequency	33
V_n	Output noise voltage	vs Frequency	34
V_O	Output voltage	vs Junction temperature	35
V_{OM}	Maximum peak output voltage	vs Load	36
THD	Total harmonic distortion	vs Frequency	37
		vs Load resistance	38
k_{SVR}	Power supply rejection ratio	vs Frequency	39
	Closed-loop gain and phase shift	vs Frequency	40
V_n	Output noise voltage	vs Frequency	41
Φ_m	Phase margin	vs Load capacitance	42

TYPICAL CHARACTERISTICS

QUIESENT CURRENT
 vs
 SUPPLY VOLTAGE

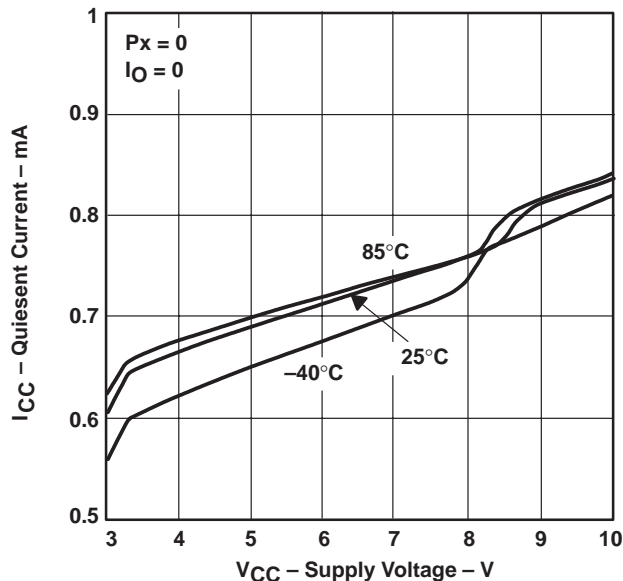

Figure 14

LDO REGULATORS
 DROPOUT VOLTAGE
 vs
 OUTPUT CURRENT

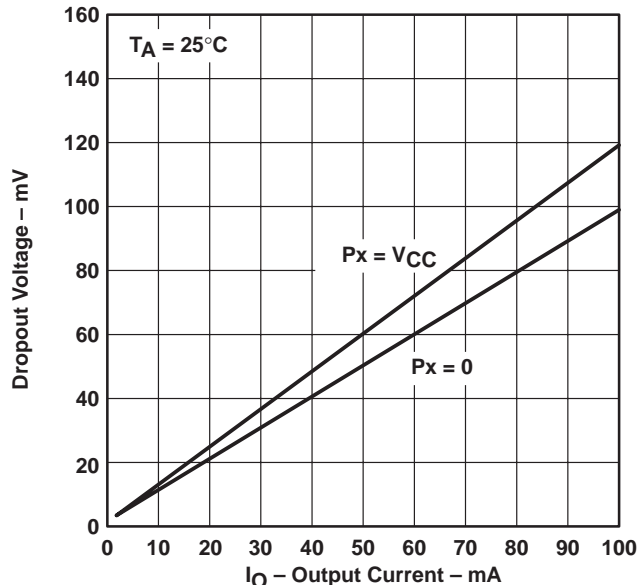

Figure 15

LDO REGULATORS
 DROPOUT VOLTAGE
 vs
 JUNCTION TEMPERATURE

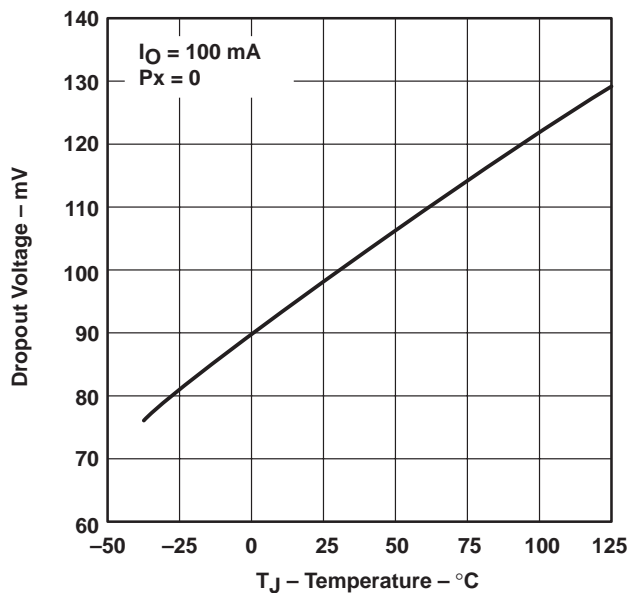

Figure 16

LDO REGULATORS
 CHANGE IN OUTPUT VOLTAGE
 vs
 JUNCTION TEMPERATURE

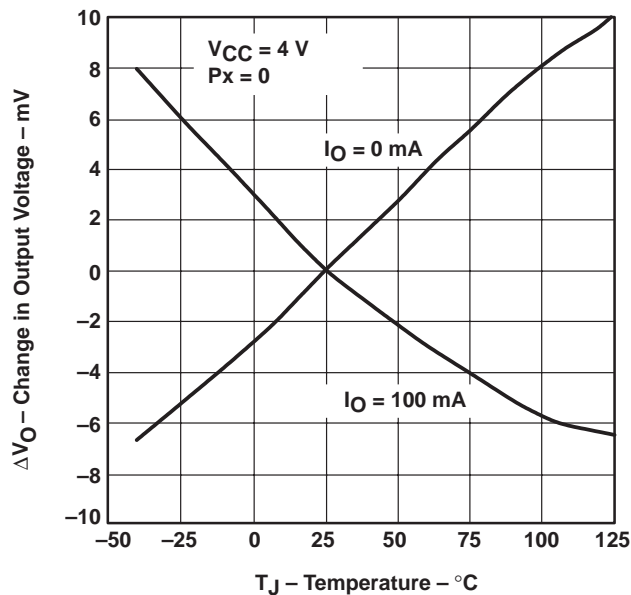

Figure 17

TYPICAL CHARACTERISTICS

REGULATOR L
 OUTPUT VOLTAGE
 vs
 SUPPLY VOLTAGE

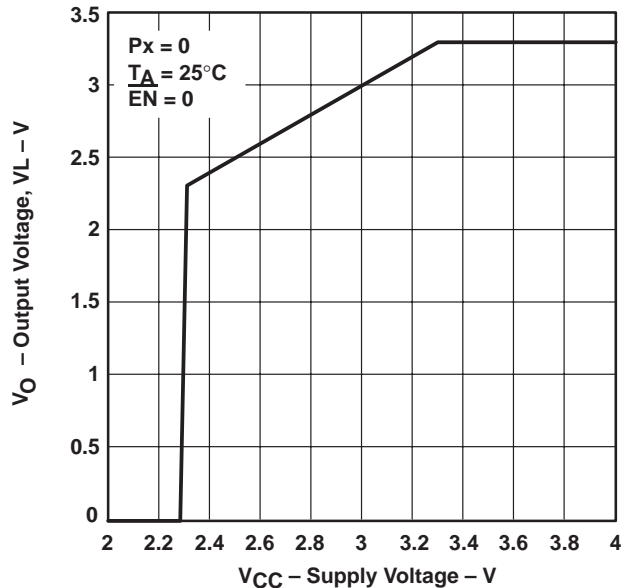

Figure 18

LDO REGULATORS
 CHANGE IN OUTPUT VOLTAGE
 vs
 SUPPLY VOLTAGE

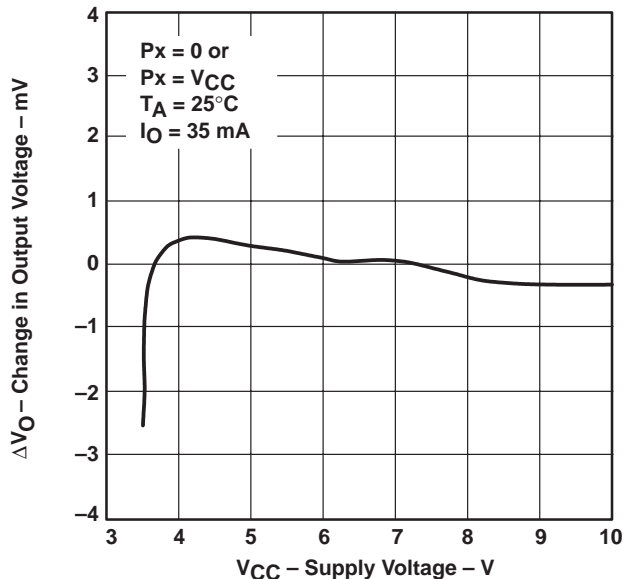

Figure 19

LDO REGULATORS
 CHANGE IN OUTPUT VOLTAGE
 vs
 OUTPUT CURRENT

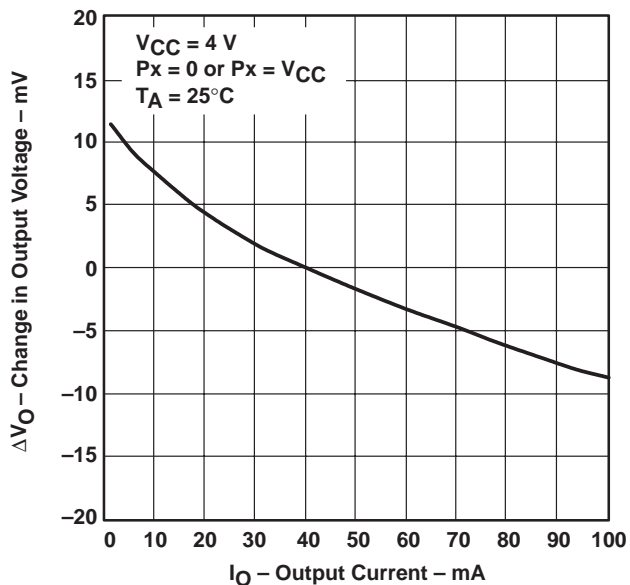

Figure 20

SHUTDOWN CURRENT
 vs
 SUPPLY VOLTAGE

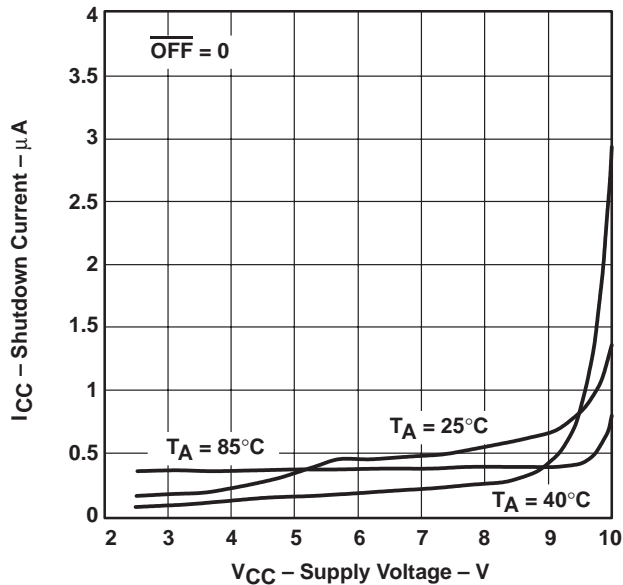
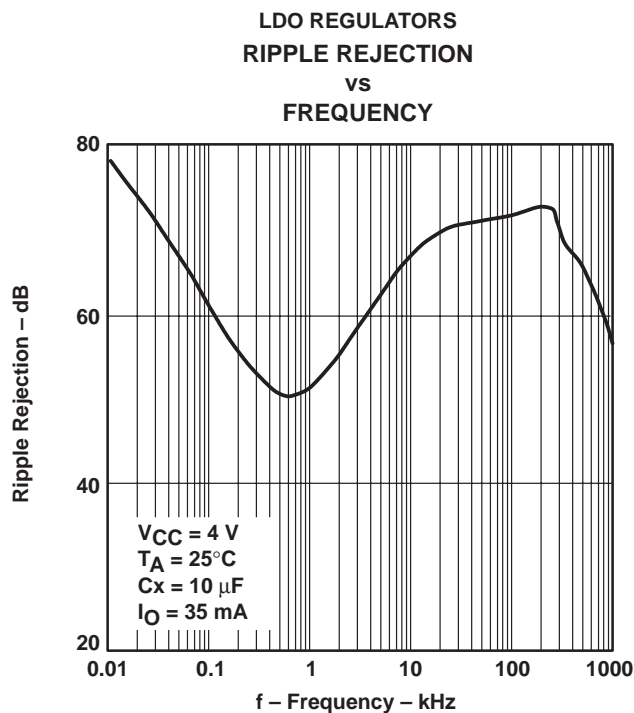
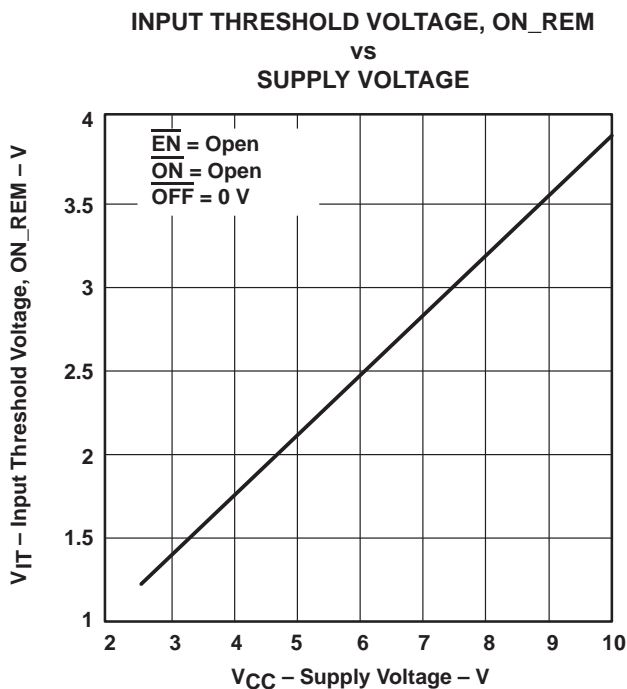
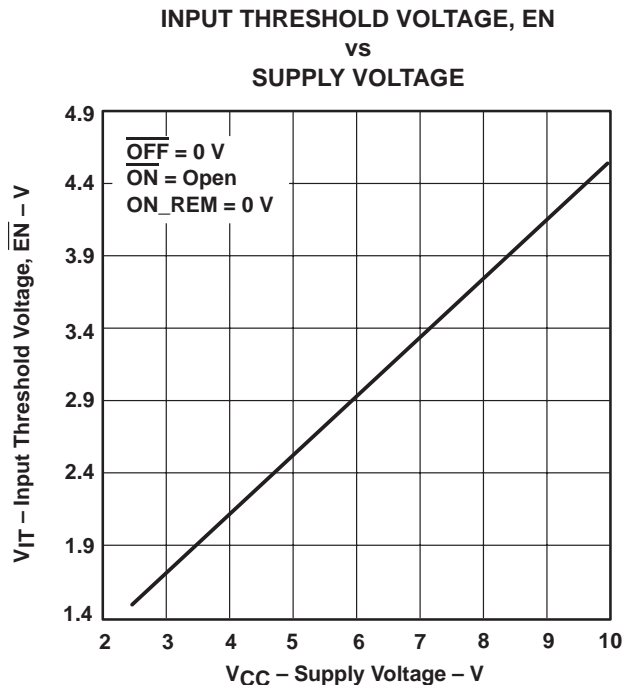
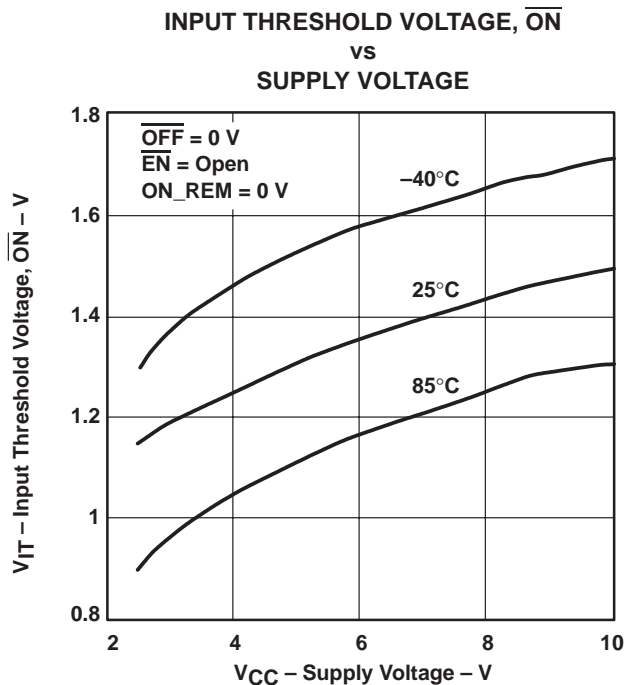

Figure 21

TYPICAL CHARACTERISTICS



TYPICAL CHARACTERISTICS

REGULATOR L
 OUTPUT SPECTRAL NOISE DENSITY
 vs
 FREQUENCY

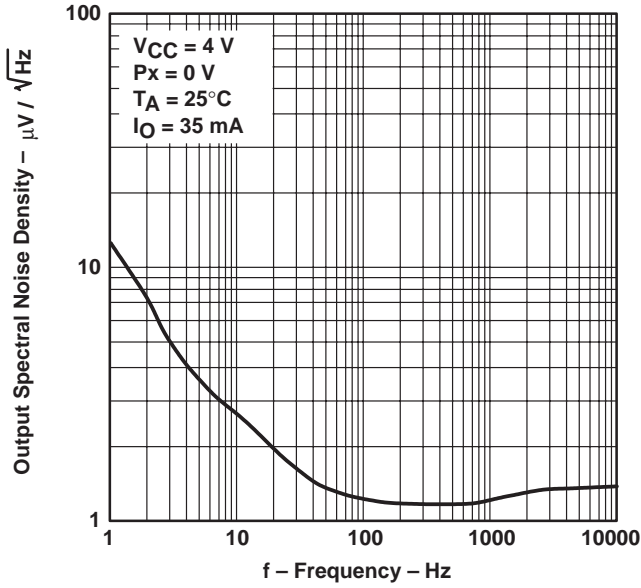

Figure 26

CHANGE IN FREQUENCY, CP
 vs
 JUNCTION TEMPERATURE

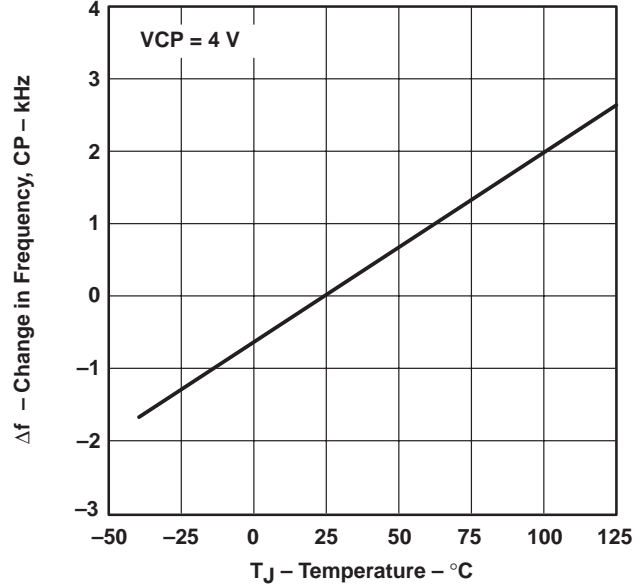

Figure 27

OUTPUT RESISTANCE, CP
 vs
 SUPPLY VOLTAGE

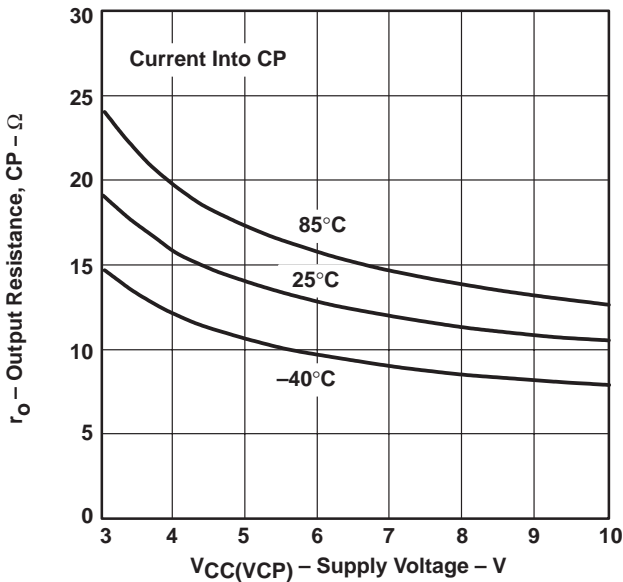

Figure 28

OUTPUT RESISTANCE, CP
 vs
 SUPPLY VOLTAGE

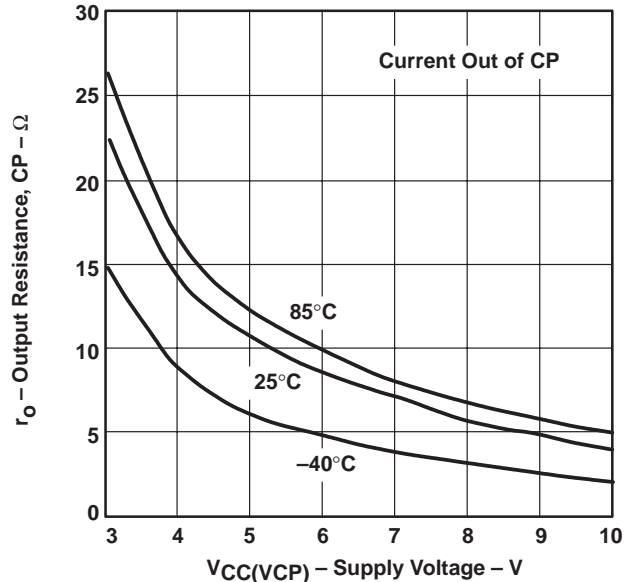
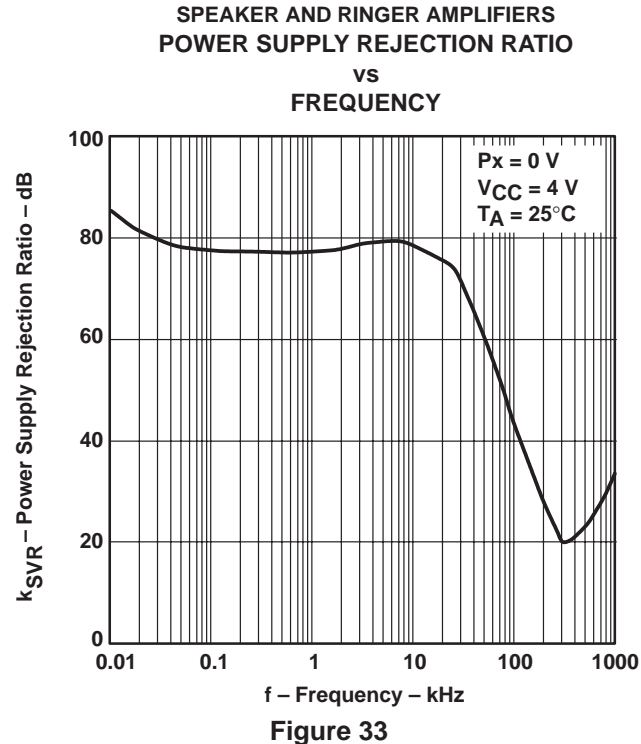
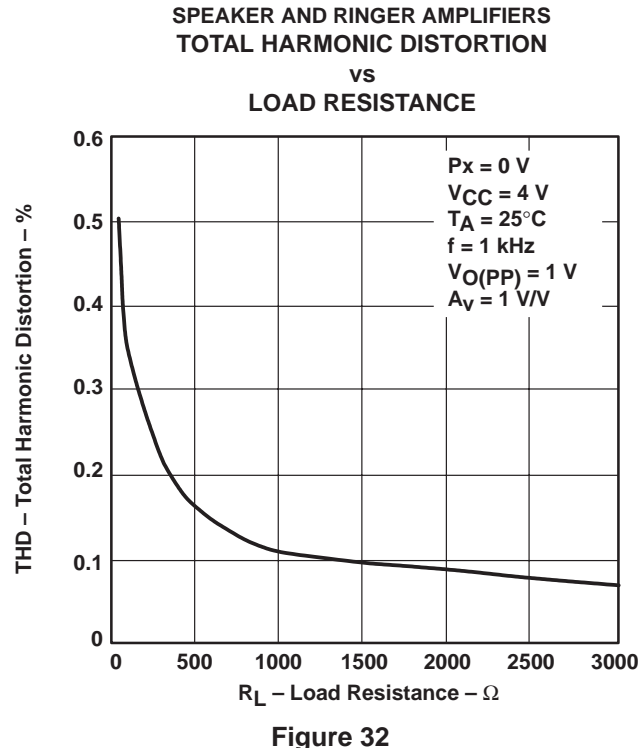
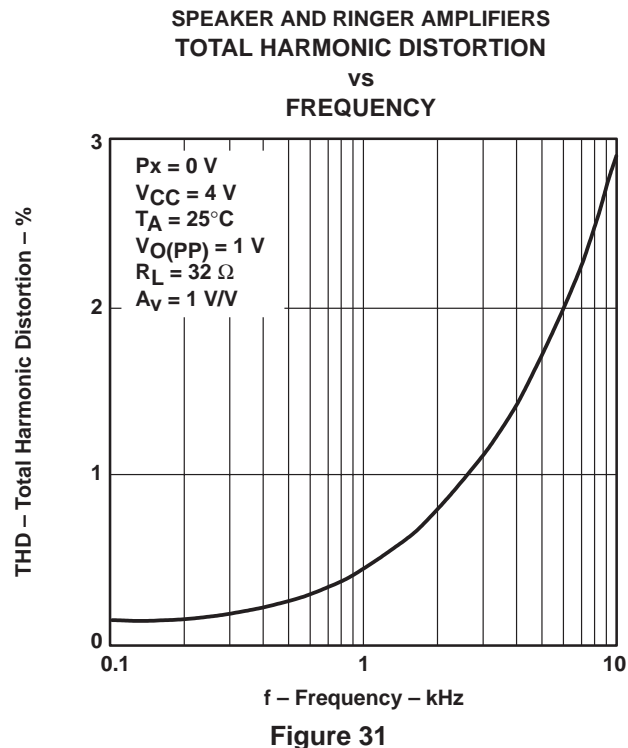
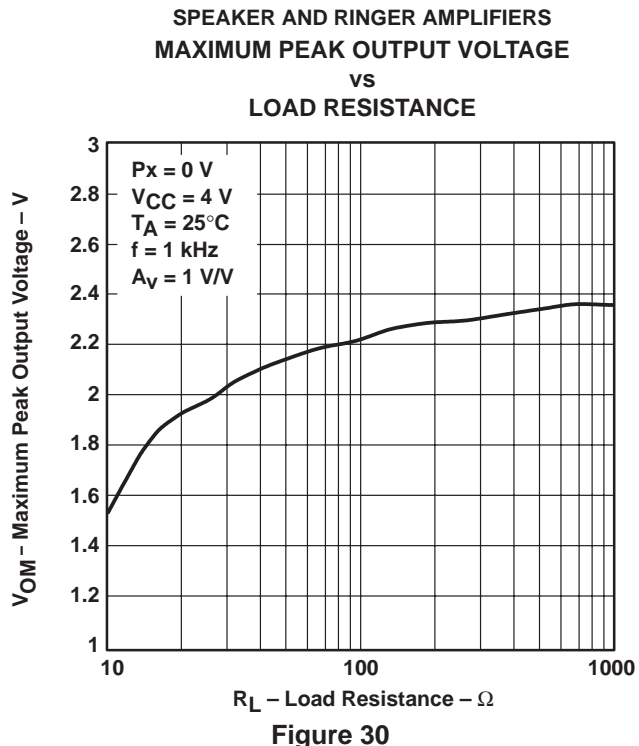

Figure 29

TYPICAL CHARACTERISTICS



TYPICAL CHARACTERISTICS

SPEAKER AND RINGER AMPLIFIERS
 OUTPUT NOISE VOLTAGE
 vs
 FREQUENCY

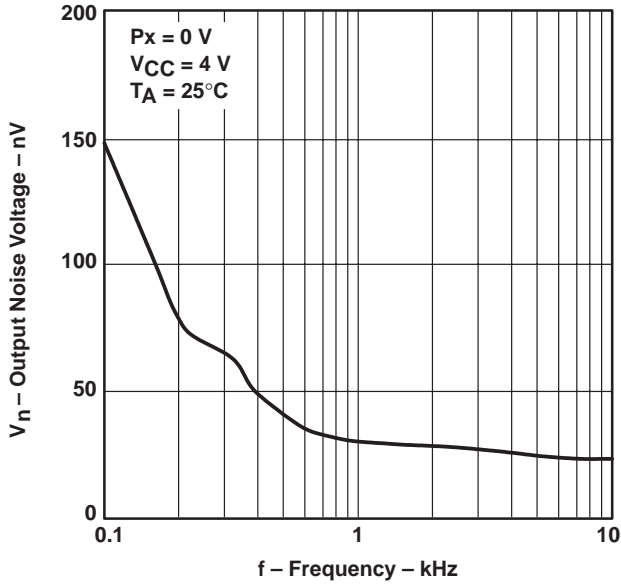

Figure 34

SPEAKER AND RINGER AMPLIFIERS
 OUTPUT VOLTAGE
 vs
 JUNCTION TEMPERATURE

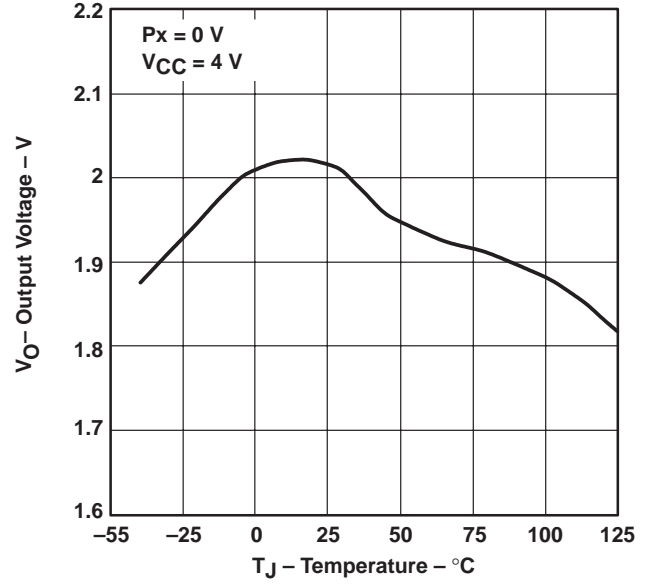

Figure 35

MICROPHONE AMPLIFIER
 MAXIMUM PEAK OUTPUT VOLTAGE
 vs
 LOAD RESISTANCE

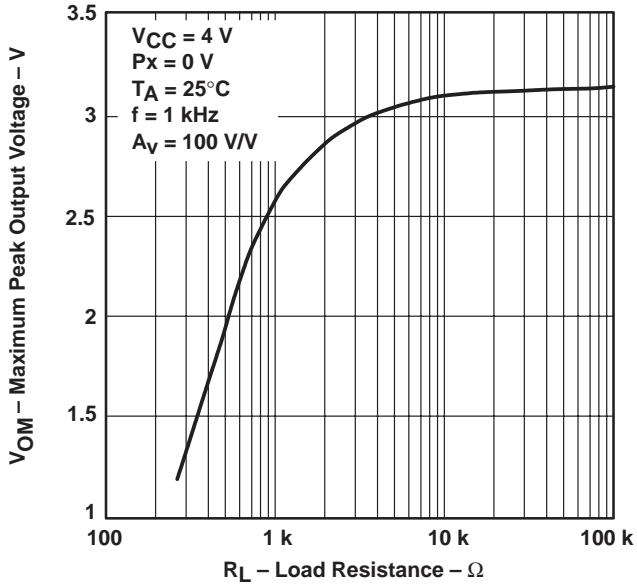

Figure 36

MICROPHONE AMPLIFIER
 TOTAL HARMONIC DISTORTION
 vs
 FREQUENCY

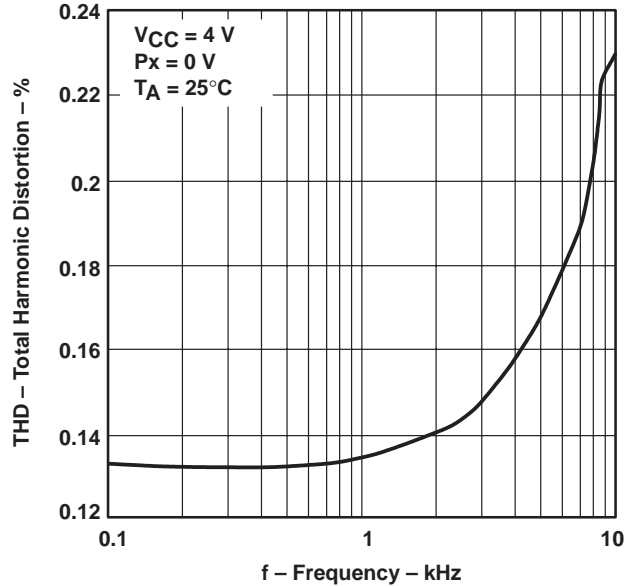

Figure 37

TYPICAL CHARACTERISTICS

MICROPHONE AMPLIFIER
 TOTAL HARMONIC DISTORTION
 VS
 LOAD RESISTANCE

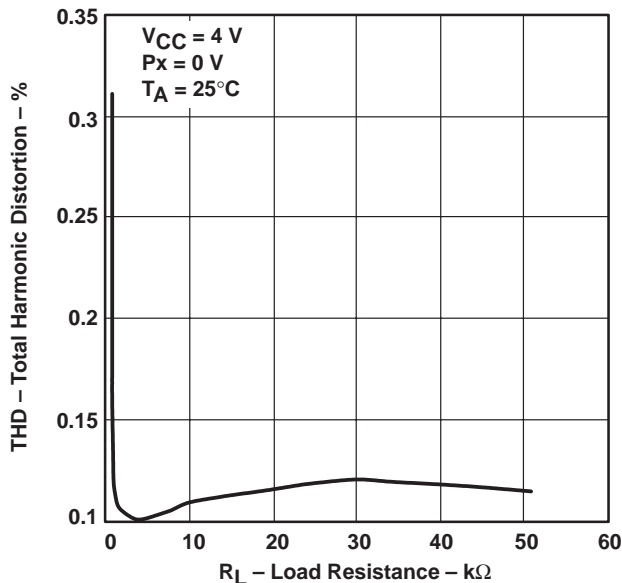

Figure 38

MICROPHONE AMPLIFIER
 POWER SUPPLY REJECTION RATIO
 VS
 FREQUENCY

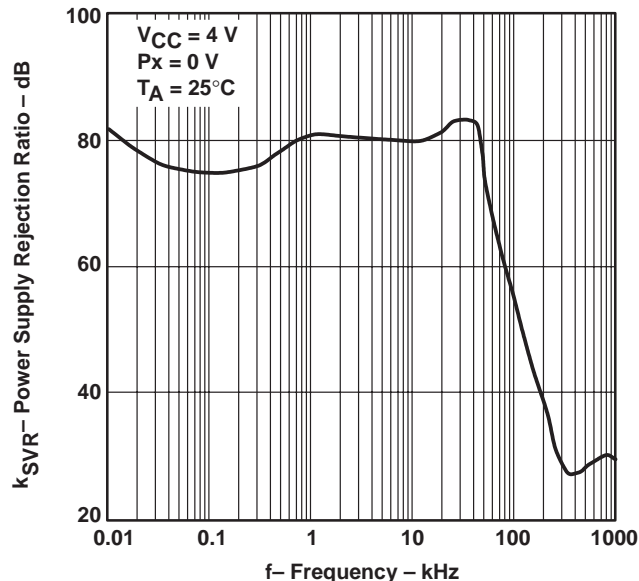

Figure 39

MICROPHONE AMPLIFIER
 CLOSED-LOOP GAIN AND PHASE SHIFT
 VS
 FREQUENCY

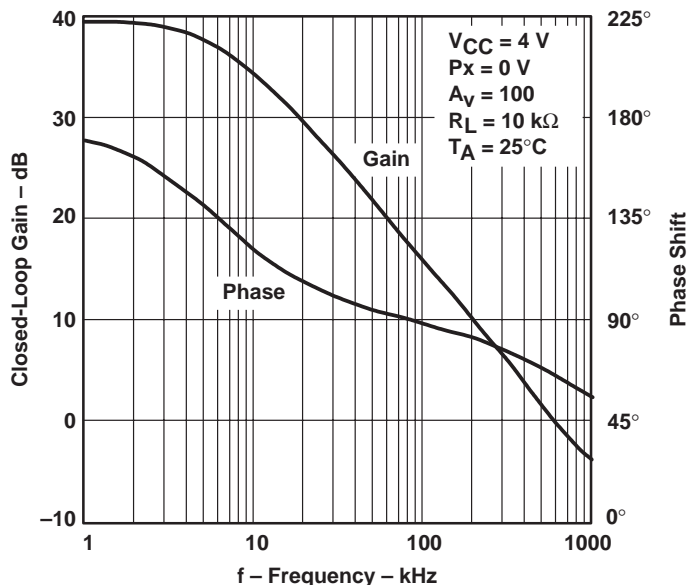

Figure 40

MICROPHONE AMPLIFIER
 OUTPUT NOISE VOLTAGE
 VS
 FREQUENCY

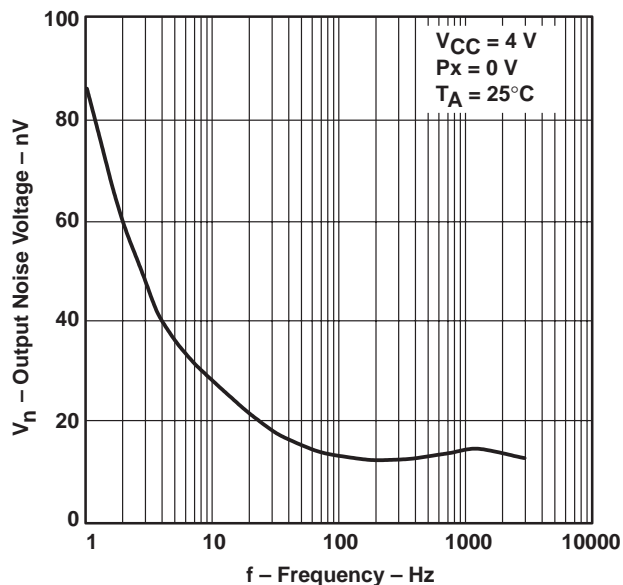

Figure 41

TYPICAL CHARACTERISTICS

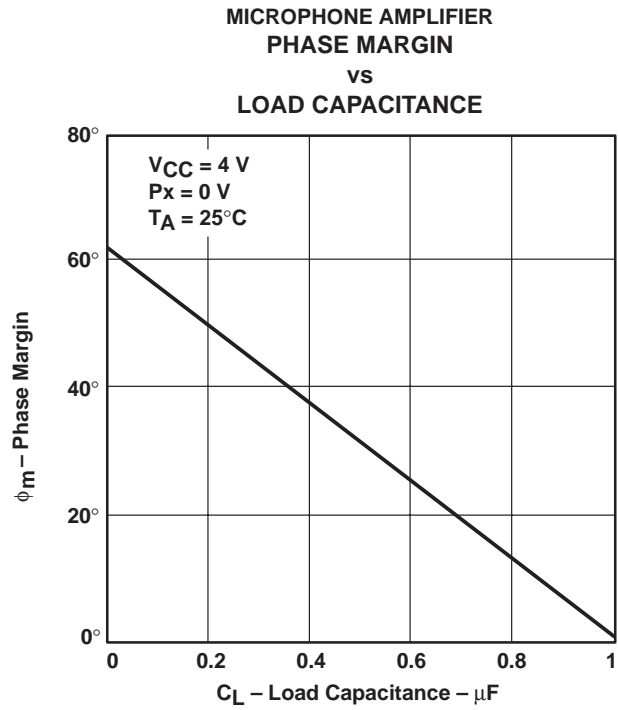

Figure 42

THERMAL INFORMATION

Using thermal resistance, junction-to-ambient ($R_{\theta JA}$), maximum power dissipation can be calculated with the equation:

$$P_{D(max)} = \frac{T_{J(max)} - T_A}{R_{\theta JA}}$$

Where $T_{J(max)}$ is the maximum allowable junction temperature or 125°C.

This limit should then be applied to the internal power dissipation of the TPS9104. The equation for calculating total internal power dissipation of the TPS9104 is:

$$P_{D(max)} = \sum_x (V_I - V_X) \times I_X + V_I \times I_Q$$

Many system-dependent issues such as thermal coupling, airflow, added heat sinks and convection surfaces, and the presence of other heat-generating components affect the power dissipation limits of a given component.

Three basic approaches for enhancing thermal performance are:

- Improving the power dissipation capability of the PWB design
- Improving the thermal coupling of the component to the PWB
- Introducing airflow in the system

APPLICATION INFORMATION

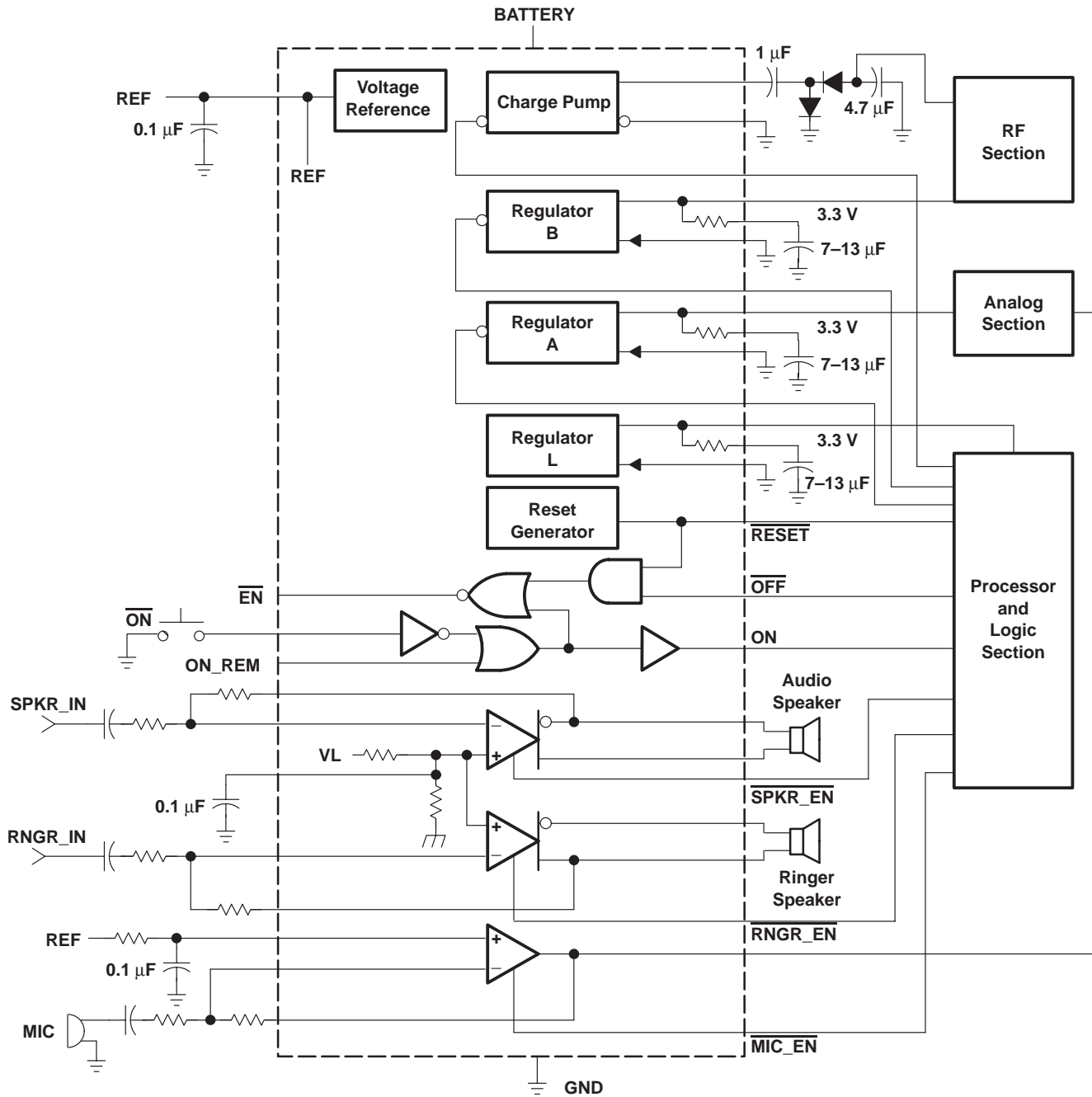

Figure 43. Typical Application

APPLICATION INFORMATION

LDOs (VL, VA, VB) output capacitors

A 10- μ F capacitor must be tied to Cx (CL, CA, or CB). The Cx terminal is connected internally to the output of the LDO through a 1- Ω resistor. The stability of LDOs is dependent on the ESR of the output filter capacitor. Most LDOs are designed to be stable over a narrow range of ESR with lower limits and upper limits, thus limiting the type of capacitor that can be used. With the use of the internal 1- Ω resistor, the lower ESR limit of the capacitor is eliminated, permitting the upper limit to be raised. Therefore, almost any tantalum or ceramic capacitor can be used, provided the ESR does not exceed 15 Ω over temperature.

charge pump design

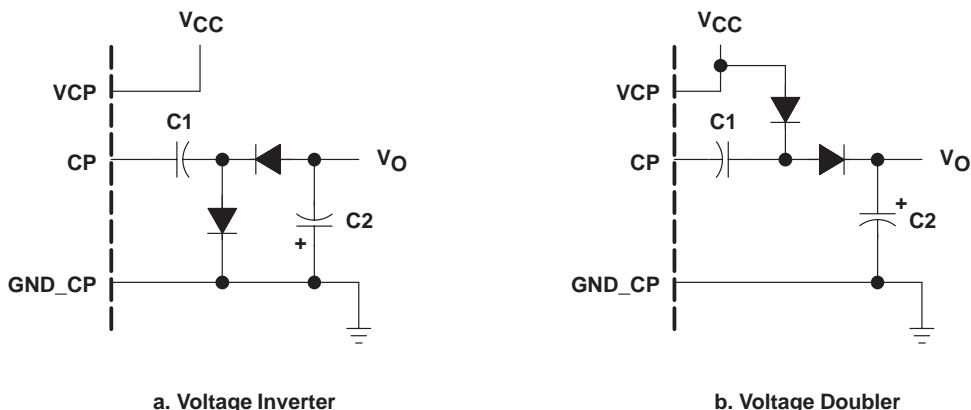

Figure 44. Charge Pump Configurations

The charge-pump terminal can drive either a voltage inverter or a voltage doubler. In either case only two capacitors and two signal diodes are needed. The output voltage is unregulated and a regulator may be added if needed.

The charge transfer of C1 is:

$$\Delta q = C1 \times (V_{CC} - V_O)$$

This occurs f times a second and the charge transfer per unit time (current) is:

$$I = f \times C1 \times (V_{CC} - V_O)$$

Rewriting this equation in the form of $I = V/R$

$$I = \frac{V_{CC} - V_O}{\frac{1}{f \times C1}}$$

where $\frac{1}{f \times C1}$ is an equivalent resistor.

APPLICATION INFORMATION

charge pump design (continued)

An equivalent circuit can now be drawn taking the diodes into account.

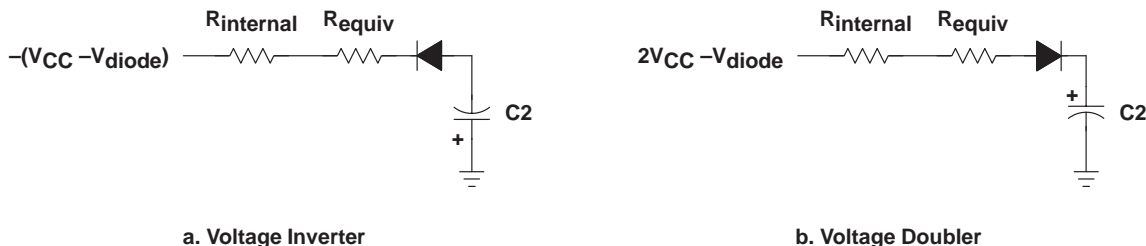

Figure 45. Equivalent Circuit

The output voltage for the doubler is then:

$$V_O = 2 \times V_{CC} - 2 \times V_{diode} - I_O \times R_{total}$$

and the output voltage for the inverter is:

$$V_O = -(V_{CC} - 2 \times V_{diode}) + I_O \times R_{total}$$

To determine the size of C1 use

$$C = \frac{I}{f \times \Delta V}$$

where $f = 100,000$ and $\Delta V =$ ripple voltage.

For an output current of 10 mA calculate

$$C1 = \frac{0.01 \text{ A}}{100 \text{ kHz} \times 0.1 \text{ V}_{ripple}} = 1 \mu\text{F}$$

Because of losses caused by diode switching and ESR, the calculated capacitance should be multiplied by 1.5 to 2. A 2- μF capacitance should drive a 10-mA voltage doubler or inverter.

amplifier design

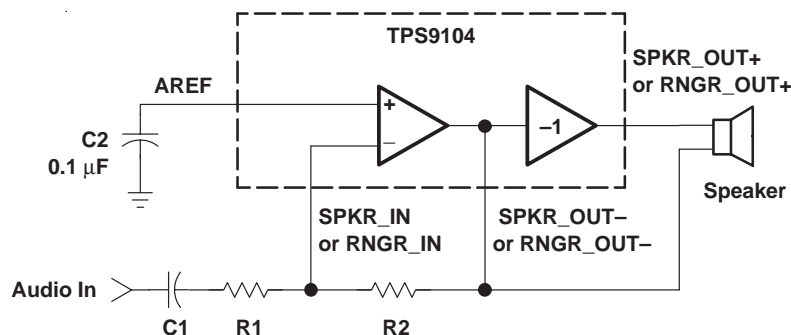

Figure 46. Speaker and Ringer Amplifiers

APPLICATION INFORMATION

amplifier design (continued)

The speaker and ringer amplifiers are capable of driving either dynamic or piezoelectric speakers. The gain is set with two external resistors connected as shown. There is an inverting stage and a noninverting stage, both of which can drive a speaker differentially. When the speaker is connected in the differential mode, the gain is doubled. The gain equation is

$$G = \frac{R2}{R1} \times 2$$

Typically R2 is in the range of 10 kΩ to 100 kΩ and the gain can be as high as 10. The noninverting amplifier input is connected to the internal reference and should be bypassed with a 0.1-μF capacitor. The audio input signal must be capacitor-coupled (refer to C1 in Figure 47). R1 and C1 determine the low-frequency pole (f_p) location. The frequency response of the input RC is:

$$f_p = \frac{1}{2 \times \pi \times R1 \times C1}$$

For a 0.22-μF capacitor and a 1-kΩ resistor, the 3-dB point is

$$f_p = \frac{1}{2 \times \pi \times 1K \times 0.22 \mu F} = 750 \text{ Hz}$$

Both V_{CC} and VL supply power to the speaker and ringer amplifiers. The output of VL is used to power the high-gain input stage, and V_{CC} is used to power the low-gain high-current output stage. When driving a highly capacitive load, series resistance should be added to minimize signal distortion.

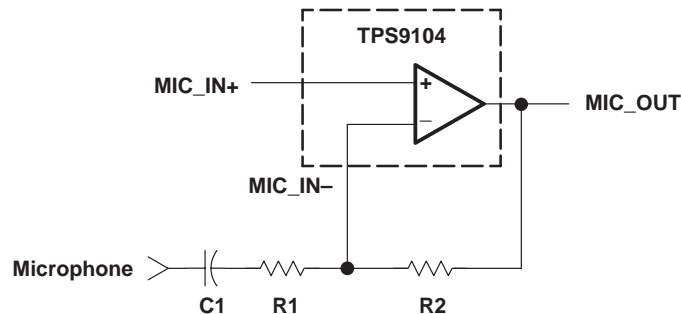

Figure 47. Microphone Amplifier

This is a high-gain amplifier capable of driving a 10 kΩ load at 3 V. The gain is set using two external resistors, R1 and R2. A low noise reference must be connected to MIC_IN+. The gain equation is: $G = \frac{R2}{R1}$. Typically R2 can be in the range of 10 kΩ to 100 kΩ and the gain can be up to 100. The microphone must be either capacitor-coupled (C1) or tied to the reference. The closed-loop -3 dB point for this amplifier is a minimum of 4 kHz. The location of the low-frequency pole can be calculated using

$$f_p = \frac{1}{2 \times \pi \times R1 \times C1}$$

TPS9104
CELLULAR SUBSCRIBER TERMINAL
POWER SUPPLY/AUDIO SYSTEM

SLVS133A – AUGUST 1996 – REVISED APRIL 1998

MECHANICAL DATA

PT (S-PQFP-G48)

PLASTIC QUAD FLATPACK

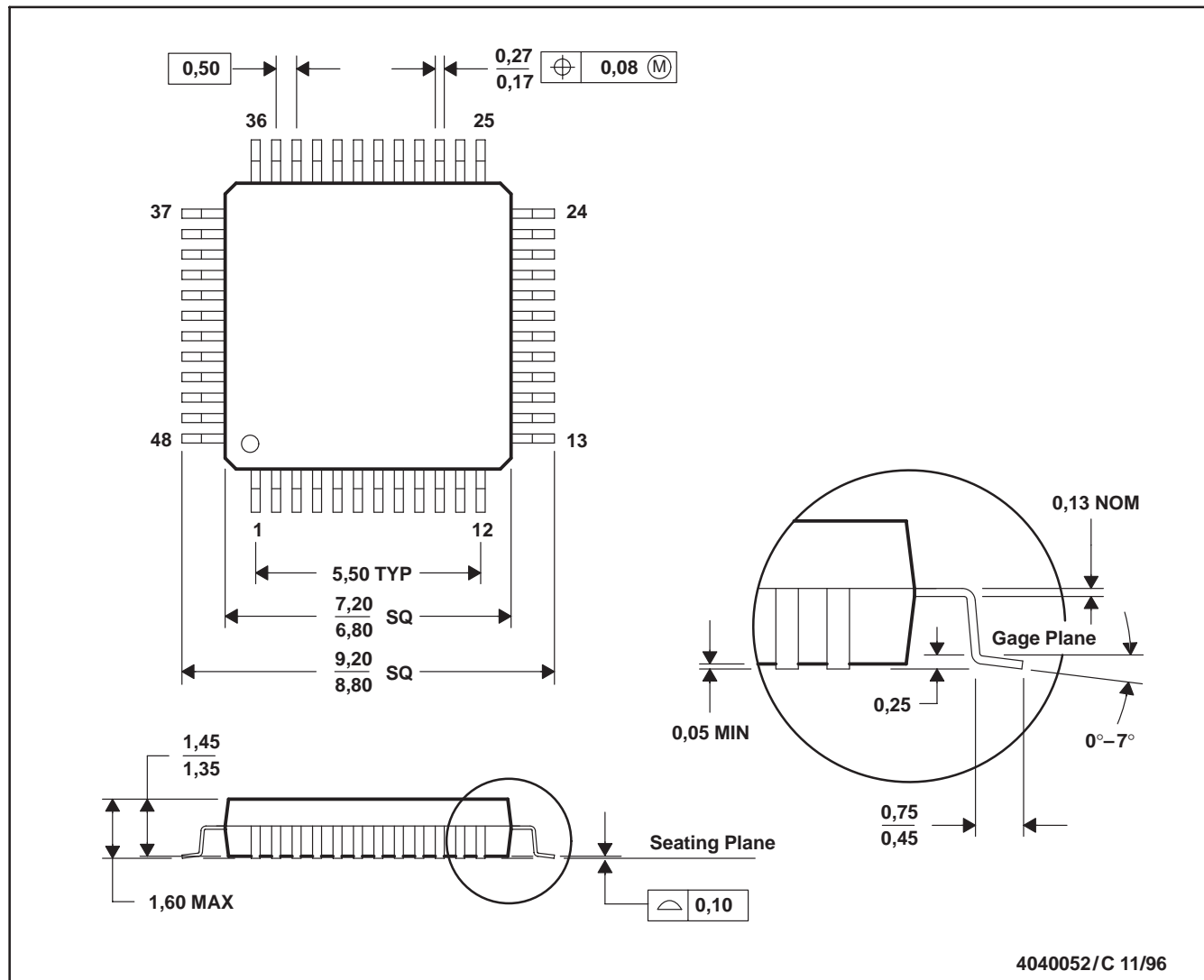

- NOTES: A. All linear dimensions are in millimeters.
 B. This drawing is subject to change without notice.
 C. Falls within JEDEC MS-026
 D. This may also be a thermally enhanced plastic package with leads connected to the die pads.

IMPORTANT NOTICE

Texas Instruments (TI) reserves the right to make changes to its products or to discontinue any semiconductor product or service without notice, and advises its customers to obtain the latest version of relevant information to verify, before placing orders, that the information being relied on is current and complete.

TI warrants performance of its semiconductor products and related software to the specifications applicable at the time of sale in accordance with TI's standard warranty. Testing and other quality control techniques are utilized to the extent TI deems necessary to support this warranty. Specific testing of all parameters of each device is not necessarily performed, except those mandated by government requirements.

Certain applications using semiconductor products may involve potential risks of death, personal injury, or severe property or environmental damage ("Critical Applications").

TI SEMICONDUCTOR PRODUCTS ARE NOT DESIGNED, INTENDED, AUTHORIZED, OR WARRANTED TO BE SUITABLE FOR USE IN LIFE-SUPPORT APPLICATIONS, DEVICES OR SYSTEMS OR OTHER CRITICAL APPLICATIONS.

Inclusion of TI products in such applications is understood to be fully at the risk of the customer. Use of TI products in such applications requires the written approval of an appropriate TI officer. Questions concerning potential risk applications should be directed to TI through a local SC sales office.

In order to minimize risks associated with the customer's applications, adequate design and operating safeguards should be provided by the customer to minimize inherent or procedural hazards.

TI assumes no liability for applications assistance, customer product design, software performance, or infringement of patents or services described herein. Nor does TI warrant or represent that any license, either express or implied, is granted under any patent right, copyright, mask work right, or other intellectual property right of TI covering or relating to any combination, machine, or process in which such semiconductor products or services might be or are used.