

TLC34075A
Video Interface Palette
Data Manual

SLAS058
April 1995



IMPORTANT NOTICE

Texas Instruments Incorporated (TI) reserves the right to make changes to its products or to discontinue any semiconductor product or service without notice, and advises its customers to obtain the latest version of relevant information to verify, before placing orders, that the information being relied on is current.

TI warrants performance of its semiconductor products and related software to current specifications in accordance with TI's standard warranty. Testing and other quality control techniques are utilized to the extent TI deems necessary to support this warranty. Specific testing of all parameters of each device is not necessarily performed, except those mandated by government requirements.

Please be aware that TI products are not intended for use in life-support appliances, devices, or systems. Use of TI product in such applications requires the written approval of the appropriate TI officer. Certain applications using semiconductor devices may involve potential risks of personal injury, property damage, or loss of life. In order to minimize these risks, adequate design and operating safeguards should be provided by the customer to minimize inherent or procedural hazards. Inclusion of TI products in such applications is understood to be fully at the risk of the customer using TI devices or systems.

TI assumes no liability for applications assistance, customer product design, software performance, or infringement of patents or services described herein. Nor does TI warrant or represent that any license, either express or implied, is granted under any patent right, copyright, mask work right, or other intellectual property right of TI covering or relating to any combination, machine, or process in which such semiconductor products or services might be or are used.

This device includes circuits that are patented and circuit designs that have patents pending.

D4049, AUGUST 1992

Copyright © 1992, Texas Instruments Incorporated

Printed in the U.S.A.

Contents

<i>Section</i>	<i>Title</i>	<i>Page</i>
1	Introduction	1-1
1.1	Features	1-1
1.2	Functional Block Diagram	1-2
1.3	Terminal Assignments	1-3
1.4	Ordering Information	1-3
1.5	Terminal Functions	1-4
2	Detailed Description	2-1
2.1	MPU Interface	2-1
2.2	Color Palette RAM	2-1
2.2.1	Writing to the Color Palette RAM	2-2
2.2.2	Reading From the Color Palette RAM	2-2
2.2.3	Palette Page Register	2-2
2.3	Input/Output Clock Selection and Generation	2-2
2.3.1	SCLK	2-4
2.3.2	VCLK	2-5
2.4	Multiplexing Scheme	2-7
2.4.1	VGA Pass-Through Mode	2-7
2.4.2	Multiplexing Modes	2-8
2.4.3	True Color Mode	2-8
2.4.4	Special Nibble Mode	2-8
2.4.5	Multiplex Control Register	2-8
2.4.6	Read Masking	2-11
2.5	Reset	2-11
2.5.1	Power-On Reset	2-11
2.5.2	Hardware Reset	2-11
2.5.3	Software Reset	2-11
2.5.4	VGA Pass-Through Mode Default Conditions	2-11
2.6	Frame Buffer Interface	2-12
2.7	Analog Output Specifications	2-12
2.8	HSYNC, VSYNC, and BLANK	2-14
2.9	Split Shift Register Transfer VRAMs and Special Nibble Mode	2-14
2.9.1	Split Shift Register Transfer VRAMs	2-14
2.9.2	Special Nibble Mode	2-15
2.10	MUXOUT Output	2-16
2.11	General Control Register	2-16
2.11.1	HSYNCOOUT and VSYNCOOUT (Bits 0 and 1)	2-17
2.11.2	Split Shift Register Transfer Enable (SSRT) and Special Nibble Mode Enable (SNM) (Bits 2 and 3)	2-17

Contents (Continued)

<i>Section</i>	<i>Title</i>	<i>Page</i>
	2.11.3 Pedestal Enable Control (Bit 4)	2-17
	2.11.4 Sync Enable Control (Bit 5)	2-17
	2.11.5 MUXOUT (Bit 7)	2-17
2.12	Test Register	2-18
	2.12.1 Frame Buffer Data Flow Test	2-19
	2.12.2 Identification Code	2-19
	2.12.3 Ones Accumulation Screen Integrity Test	2-19
	2.12.4 Analog Test	2-19
3	Specifications	3-1
3.1	Absolute Maximum Ratings Over Operating Free-Air Temperature Range (Unless Otherwise Noted)	3-1
3.2	Recommended Operating Conditions	3-1
3.3	Electrical Characteristics	3-2
3.4	Operating Characteristics	3-3
3.5	Timing Requirements	3-4
3.6	Switching Characteristics	3-5
	TL34075A-66, TLC34075A-85	3-5
	TL34075A-110, TLC34075A-135	3-6
3.7	Timing Diagrams	3-7
Appendix A	SCLK/VCLK and the TMS340x0	A-1
Appendix B	PC Board Layout Considerations	B-1
Appendix C	SCLK Frequency < VCLK Frequency	C-1
Appendix D	Mechanical Data	D-1

List of Illustrations

<i>Figure</i>	<i>Title</i>	<i>Page</i>
1-1	Functional Block Diagram	1-2
1-2	Terminal Assignments	1-3
2-1	DOTCLK/VCLK/SCLK Relationship	2-3
2-2	SCLK/VCLK Control Timing	2-5
2-3	SCLK/VCLK Control Timing	2-6
2-4	SCLK/VCLK Control Timing	2-6
2-5	SCLK/VCLK Control Timing	2-7
2.6	Equivalent Circuit of the IOG Current Output	2-12
2-7	7.5-IRE, 8-Bit Composite Video Output	2-13
2-8	0-IRE, 8-Bit Composite Video Output	2-13
2-9	Relationship Between SFLAG/NFLAG, <u>BLANK</u> , and SCLK	2-15
2-10	SFLAG/NFLAG Timing in Special Nibble Mode	2-16
2-11	Test Register Control Word State Diagrams	2-18
2-12	Internal Comparator Circuitry for Analog Test	2-20
3-1	MPU Interface Timing	3-7
3-2	Video Input/Output	3-8
3-3	SFLAG/NFLAG Timing	3-8

List of Tables

<i>Table</i>	<i>Title</i>	<i>Page</i>
2-1	Internal Register Map	2-1
2-2	Allocation of Palette Page Register Bits	2-2
2-3	Input Clock Selection Register Format	2-3
2-4	Output Clock Selection Register Format	2-4
2-5	VCLK/SCLK Divide Ratio Selection	2-4
2-6	Mode and Bus Width Selection	2-9
2-7	Pixel Data Distribution in Special Nibble Mode	2-15
2-8	General Control Register Bit Functions	2-17
2-9	Test Mode Selection	2-18
2-10	Test Register Bit Definitions for Analog Test	2-20
2-11	D<7:4> Bit Coding for Analog Comparisons	2-20

1 Introduction

The TLC34075A Video Interface Palette (VIP) is designed to provide lower system cost with a higher level of integration by incorporating all the high-speed timing, synchronizing, and multiplexing logic usually associated with graphics systems into one device, thus greatly reducing chip count. Since all high-speed signals (excluding the clock source) are contained on-chip, RF noise considerations are simplified. Maximum flexibility is provided through the pixel multiplexing scheme, which allows for 32-, 16-, 8-, and 4-bit pixel buses to be accommodated without any circuit modification. This enables the system to be easily reconfigured for varying amounts of available video RAM. Data can be split into 1, 2, 4, or 8 bit planes. The TLC34075A is software-compatible with the INMOS IMMSG176/8 and Brooktree BT476/8 color palettes.

The TLC34075A features a separate VGA bus that allows data from the feature connector of most VGA-supported personal computers to be fed directly into the palette without the need for external data multiplexing. This allows a replacement graphics board to remain downward compatible by utilizing the existing graphics circuitry often located on the motherboard. The TLC34075A also provides a true color mode in which 24 (3 by 8) bits of color information are transferred directly from the pixel port to the DACs. This mode of operation supplies an overlay function using the 8 remaining bits of the pixel bus.

The TLC34075A has a 256-by-24 color lookup table with triple 8-bit video D/A converters capable of directly driving a doubly terminated 75- Ω line. Sync generation is incorporated on the green output channel. HSYNC and VSYNC are fed through the device and optionally inverted to indicate screen resolution to the monitor. A palette page register provides the additional bits of palette address when 1, 2, or 4 bit planes are used. This allows the screen colors to be changed with only one MPU write cycle.

Clocking is provided through one of four or five inputs (3 TTL- and either 1 ECL- or 2 TTL-compatible) and is software selectable. The video and shift clock outputs provide a software-selected divide ratio of the chosen clock input.

The TLC34075A can be connected directly to the serial port of VRAM devices, eliminating the need for any discrete logic. Support for split shift register transfers is also provided.

The TLC34075A is an optimized version of the original TLC34075 video interface palette. Because all of the critical speed paths have been strengthened on the device, a slightly higher I_{DD} current specification is required. The new specification also includes revised SCLK/VCLK timing and a clock counter reset function.

1.1 Features

- Versatile multiplexing interface allows lower pixel bus rate
- High level of integration provides lower system cost and complexity
- Direct VGA pass-through capability
- Directly interfaces to TMS34010/TMS34020 and other graphics processors
- Triple 8-bit D/A converters
- 66-, 85-, 110-, and 135-MHz versions
- 256-word color palette RAM
- Palette page register
- On-chip voltage reference
- RS-343A-compatible outputs
- TTL-compatible inputs
- Standard MPU interface
- Pixel word mask
- On-chip clock selection
- True color (direct addressing) mode
- Directly interfaces to video RAM
- Supports split shift register transfers
- Software downward-compatible with INMOS IMMSG176/8 and Brooktree BT476/8 color palettes

- TIGA™-software-standard compatible
- LinEPIC™ 1-μm CMOS process

1.2 Functional Block Diagram

LinEPIC and TIGA are trademarks of Texas Instruments Incorporated.

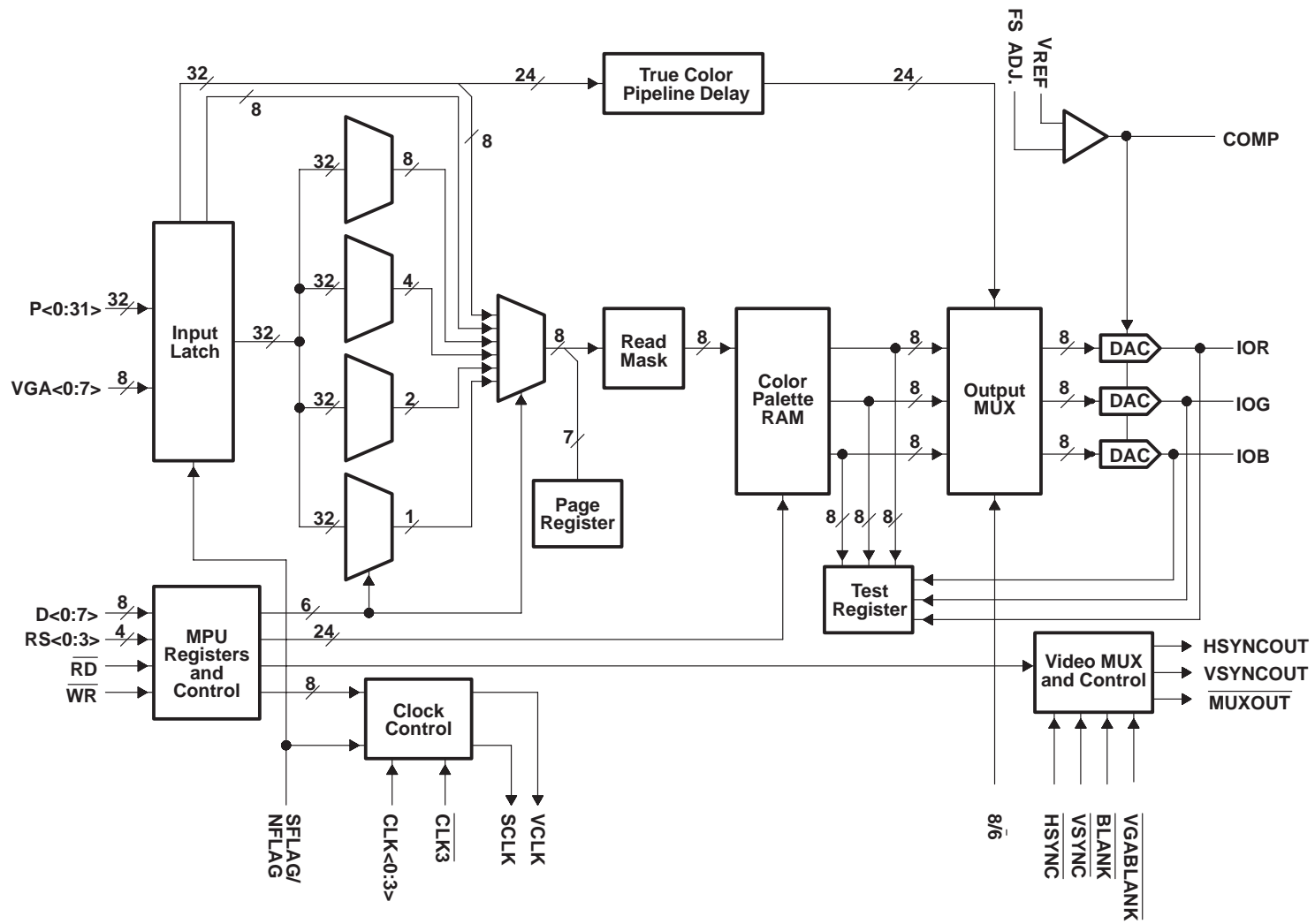

Figure 1-1. Functional Block Diagram

1.3 Terminal Assignments

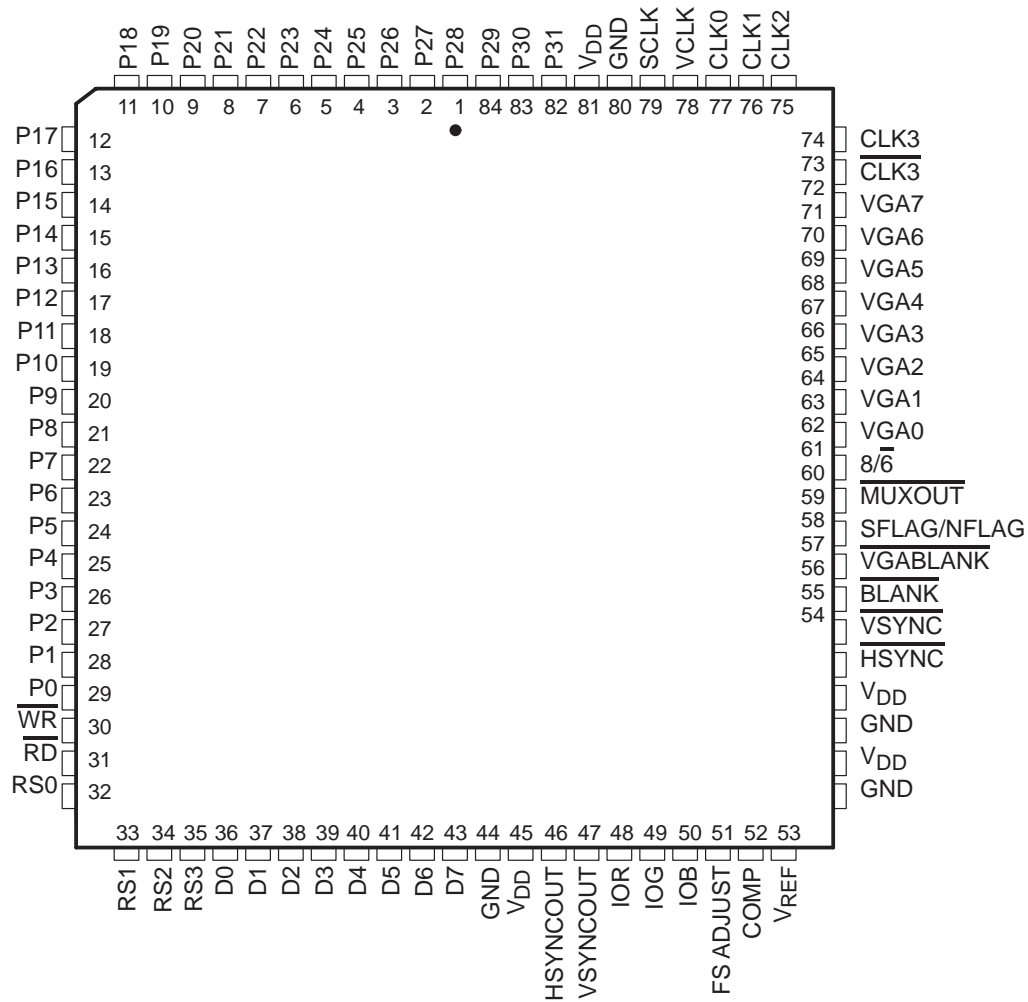

Figure 1–2. Terminal Assignments

1.4 Ordering Information

TLC34075A – (X)XX AFN

Pixel clock frequency indicator

MUST CONTAIN TWO OR THREE CHARACTERS:

- 66: 66-MHz pixel clock
- 85: 85-MHz pixel clock
- 110: 110-MHz pixel clock
- 135: 135-MHz pixel clock

Package

MUST CONTAIN TWO LETTERS:

FN: plastic, square, leaded chip carrier (formed leads)

1.5 Terminal Functions

PIN NAME	NO.	I/O	DESCRIPTION
BLANK, VGABLANK	60, 61	I	Blanking inputs. Two blanking inputs are provided in order to remove any external multiplexing of the signals that may cause data and blank to skew. When the VGA pass-through mode is set in the mux control register, the VGABLANK input is used for blanking; otherwise, BLANK is used.
CLK<0:2>	77, 76, 75	I	Dot clock inputs. Any of the three clocks can be used to drive the dot clock at frequencies up to 85 MHz. When VGA pass-through mode is active, CLK0 is used by default.
CLK3, CLK3	74, 73	I	Dual-mode dot clock input. This input is an ECL-compatible input, but a TTL clock may be used on either CLK3 or CLK3 if so selected in the input clock selection register. This input may be selected as the dot clock for any frequency of operation up to the device limit while in the ECL mode; it may only be used up to 85 MHz in the TTL mode.
COMP	52	I	Compensation input. This terminal provides compensation for the internal reference amplifier. A resistor and ceramic capacitor are required between this terminal and V _{DD} . The resistor and capacitor must be as close to the device as possible to avoid noise pickup. Refer to Appendix B for more details.
D<0:7>	36–43	I/O	MPU interface data bus. Used to transfer data in and out of the register map and palette/overlay RAM.
FS ADJUST	51	I	Full-scale adjustment pin. A resistor connected between this pin and ground controls the full-scale range of the DACs.
GND	44, 54, 56, 80		Ground. All GND pins must be connected. The analog and digital GND pins are connected internally.
HSYNCOUT, VSYNCOUT	46, 47	O	Horizontal and vertical sync outputs of the true/complement gate mentioned in the HSYNC, VSYNC description below (see Section 2.8).
HSYNC, VSYNC	58, 59	I	Horizontal and vertical sync inputs. These signals are used to generate the sync level on the green current output. They are active-low inputs for the normal modes and are passed through a true/complement gate. For the VGA pass-through mode, they are passed through to HSYNCOUT and VSYNCOUT without polarity change as specified by the control register (see Section 2.8).
IOR, IOG, IOB	48, 49, 50	O	Analog current outputs. These outputs can drive a 37.5-Ω load directly (doubly terminated 75-Ω line), thus eliminating the need for any external buffering.
MUXOUT	63	O	MUX output control. This output pin is software programmable. It is set low to indicate to external devices that VGA pass-through mode is being used when the MUX control register value is set to 2Dh. If bit 7 of the general control register is set high after the mode is set, this output goes high. This pin is only used for external control; it affects no internal circuitry.
P<0:31>	29–1, 84–82	I	Pixel input port. This port can be used in various modes as shown in the MUX control register. It is recommended that unused pins be tied to ground to lower the device's power consumption.
RD	31	I	Read strobe input. A low logic level on this pin initiates a read from the TLC34075A register map. Reads are performed asynchronously and are initiated on the falling edge of RD (see Figure 3–1).
RS<0:3>	32–35	I	Register select inputs. These pins specify the location in the register map that is to be accessed, as shown in Table 2–1.
SCLK	79	O	Shift clock output. This output is selected as a submultiple of the dot clock input. SCLK is gated off during blanking.

1.5 Terminal Functions (continued)

PIN NAME	NO.	I/O	DESCRIPTION
SFLAG/NFLAG	62	I	Split shift register transfer flag or nibble flag input. This pin has two functions. When the general control register bit 3 = 0 and bit 2 = 1, split shift register transfer function is enabled and a low-to-high transition on this pin during a blank sequence initiates an extra SCLK cycle to allow a split shift register transfer in the VRAMs. When the general control register bit 3 = 1 and bit 2 = 0, special nibble mode is enabled and this input is sampled at the falling edge of VCLK. A high value sampled indicates that the next SCLK rising edge should latch the high nibble of each byte of the pixel data bus; a low value sampled indicates that the low nibble of each byte of the pixel data bus should be latched (see Section 2.9). When the general control register bit 3 = 0 and bit 2 = 0, this pin is ignored. The condition of bit 3 = 1, bit 2 = 1 is not allowed, and device operation is unpredictable if they are so set.
VCLK	78	O	Video clock output. User-programmable output for synchronization of the TLC34075A to a graphics processor.
VDD	45, 55, 57, 81		Power. All VDD pins must be connected. The analog and digital VDD pins are connected internally.
VGA<0:7>	65–72	I	VGA pass-through bus. This bus can be selected as the pixel bus for VGA pass-through mode. It does not allow for any multiplexing.
VREF	53		Voltage reference for DACs. An internal voltage reference of nominally 1.235 V is designed in. A 0.1- μ f ceramic capacitor between this terminal and GND is recommended for noise filtering using either the internal or an external reference voltage. The internal reference voltage can be overridden by an externally supplied voltage. The typical connection is shown in Appendix B.
WR	30	I	Write strobe input. A low logic level on this pin initiates a write to the TLC34075A register map. Write transfers are asynchronous. The data written to the register map is latched on the rising edge of \overline{WR} (see Figure 3–1).
8/6	64	I	DAC resolution selection. This pin is used to select the data bus width (8 or 6 bits) for the DACs and is provided to maintain compatibility with the INMOS IM5G176/8 color palette. When this pin is at a high logic level, 8-bit bus transfers are used, with D<7> being the MSB and D<0> the LSB. For 6-bit bus operation, while the color palette still has the 8-bit information, D<5> shifts to the bit 7 position, D<0> shifts to the bit 2 position, and the two LSBs are filled with zeros at the output MUX to the DAC. When read in the 6-bit mode, the palette-holding register zeroes out the two MSBs.

NOTES: 1. Although leaving unused pins floating will not adversely affect device operation, tying unused pins to ground lowers power consumption and, thus, is recommended.

2. All digital inputs and outputs are TTL-compatible, unless otherwise noted.

2 Detailed Description

2.1 MPU Interface

The processor interface is controlled via read and write strobes (\overline{RD} , \overline{WR}), four register select pins (RS<0:3>), and the $8/\overline{6}$ select pin. The $8/\overline{6}$ select pin is used to select between 8- or 6-bit operation and is provided in order to maintain compatibility with the IM5G176/8 color palette. This operation is carried out in order to utilize the maximum range of the DACs.

The internal register map is shown in Table 2–1. The MPU interface operates asynchronously, with data transfers being synchronized by internal logic. All the register locations support read and write operations.

Table 2–1. Internal Register Map

RS3	RS2	RS1	RS0	REGISTER ADDRESSED BY MPU
L	L	L	L	Palette address register – write mode
L	L	L	H	Color palette holding register
L	L	H	L	Pixel read mask
L	L	H	H	Palette address register – read mode
L	H	L	L	Reserved
L	H	L	H	Reserved
L	H	H	L	Reserved
L	H	H	H	Reserved
H	L	L	L	General control register
H	L	L	H	Input clock selection register
H	L	H	L	Output clock selection register
H	L	H	H	Mux control register
H	H	L	L	Palette page register
H	H	L	H	Reserved
H	H	H	L	Test register
H	H	H	H	Reset state

2.2 Color Palette RAM

The color palette RAM is addressed by two internal 8-bit registers, one for reading from the RAM and one for writing to the RAM. These registers are automatically incremented following a RAM transfer, allowing the entire palette to be read/written with only one access of the address register. When the address register increments beyond the last location in RAM, it is reset to the first location (address 0). Although all read and write accesses to the RAM are asynchronous to SCLK, VCLK, and the dot clock, they are performed within one dot clock and so do not cause any noticeable disturbance on the display.

The color palette RAM is 24 bits wide for each location (8 bits each for red, green, and blue). If 6-bit mode is chosen ($8/\overline{6}$ = low), the two MSBs are still written to the color palette RAM. However, if they are read back in the 6-bit mode, the two MSBs are set to 0 to maintain compatibility with the IM5G176/8 and BT476/8 color palettes. The output MUX shifts the six LSBs to the six MSB positions, fills the two LSBs with 0s, then feeds the eight bits to the DAC. With the $8/\overline{6}$ pin held low, data on the lowest six bits of the data bus are internally shifted up by two bits to occupy the upper six bits at the output MUX, and the bottom two bits are then zeroed. The test register and the ones accumulation register both take data before the output MUX to give the user the maximum flexibility.

The color palette RAM access methodology is described in the following two sections and is fully compatible with the IM5G176/8 and BT476/8 color palettes.

2.2.1 Writing to the Color Palette RAM

To load the color palette RAM, the MPU must first write to the address register (write mode) with the address where the modification is to start. This action is followed by three successive writes to the palette-holding register with eight bits each of red, green, and blue data. After the blue data write cycle, the three bytes of color are concatenated into a 24-bit word and written to the color palette RAM location specified by the address register. The address register then increments to point to the next color palette RAM location, which the MPU may modify by simply writing another sequence of red, green, and blue data bytes. A block of color values in consecutive locations may be written to by writing the start address and performing continuous red, green, and blue write cycles until the entire block has been written.

2.2.2 Reading From the Color Palette RAM

Reading from the color palette RAM is performed by writing the location to be read to the address register. This action initiates a transfer from the color palette RAM into the holding register followed by an increment of the address register. Three successive MPU reads from the holding register produce red, green, and blue color data (six or eight bits, depending on the 8/6 mode) for the specified location. Following the blue read cycle, the contents of the color palette RAM at the address specified by the address register are copied into the holding register and the address register is again incremented. As with writing to the color palette RAM, a block of color values in consecutive locations may be read by writing the start address and performing continuous red, green, and blue read cycles until the entire block has been read.

2.2.3 Palette Page Register

The 8-bit palette page register provides high-speed color changing by removing the need for color palette RAM reloading. When using 1, 2, or 4 bit planes, the additional planes are provided by the palette page register; e.g., when using four bit planes, the pixel inputs specify the lower four bits of the color palette RAM address with the upper four bits being specified by the palette register. This provides the capability of selecting from 16 palette pages with only one chip access, thus allowing all the screen colors to be changed at the line frequency. A bit-to-bit correspondence is used; therefore, in the above configuration, palette page register bits 7 through 4 map onto color palette RAM address bits 7 through 4, respectively. This is illustrated below.

NOTE: The additional bits from the palette page register are inserted before the read mask and hence, are subject to masking.

Table 2–2. Allocation of Palette Page Register Bits

NUMBER OF BIT PLANES	COLOR PALETTE RAM ADDRESS BITS							
	msb							isb
8	M	M	M	M	M	M	M	M
4	P7	P6	P5	P4	M	M	M	M
2	P7	P6	P5	P4	P3	P2	M	M
1	P7	P6	P5	P4	P3	P2	P1	M

Pn = nth bit from palette page register

M = bit from pixel port

2.3 Input/Output Clock Selection and Generation

The TLC34075A provides a maximum of five clock inputs. Three are dedicated to TTL inputs; the other two can be selected as either one ECL input or two extra TTL inputs. The TTL inputs can be used for video rates up to 85 MHz, above which an ECL clock source must be used (although the ECL clock may also be used at lower frequencies). The dual-mode clock input (ECL/TTL) is primarily an ECL input but can be used as a TTL-compatible input if the input clock selection register is so programmed. The clock source used at power-up is CLK0; an alternative source can be selected by software during normal operation. This chosen clock input is used unmodified as the dot clock (representing the pixel rate to the monitor). The device does,

however, allow for user programming of the SCLK and VCLK outputs (shift and video clocks) via the output clock selection register. The input/output clock selection registers are shown in Tables 2–3, 2–4, and 2–5.

SCLK is designed to drive the VRAMs directly, and VCLK is designed to work with video control signals such as BLANK and the SYNCs. While SCLK and VCLK are designed as general-purpose shift clock and video clock, respectively, they also interface directly with the TMS340x0 GSP family. While SCLK and VCLK can be selected independently, there is still a relationship between the two. Internally, both SCLK and VCLK are generated from a common clock counter that increments on the rising edge of the DOTCLK. When VCLK is enabled and the VCLK and SCLK frequencies are programmed to be the same submultiple of the DOTCLK frequency, then VCLK and SCLK are in phase. When VCLK is enabled and the VCLK and SCLK frequencies are programmed to be different submultiples of the DOTCLK frequency, then there are simultaneous rising edges on the two waveforms at times determined by their frequency ratio (see Figure 2–1).

Appendix A discusses the SCLK/VCLK relationship specific to the TMS340x0 GSP.

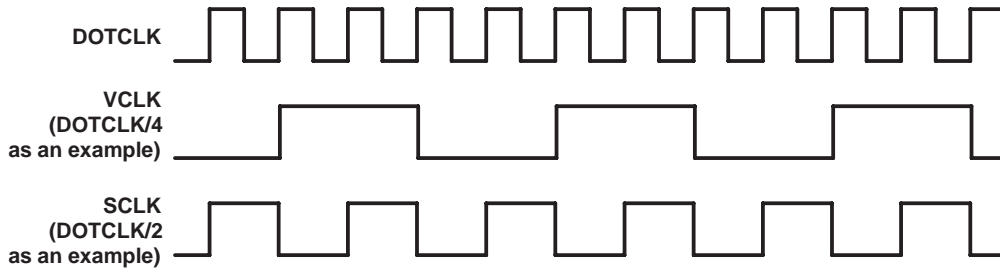

Figure 2–1. DOTCLK/VCLK/SCLK Relationship

Table 2–3. Input Clock Selection Register Format

BITS [†]				FUNCTION [‡]
3	2	1	0	
0	0	0	0	Select CLK0 as clock source [§]
0	0	0	1	Select CLK1 as clock source
0	0	1	0	Select CLK2 as clock source
0	0	1	1	Select CLK3 as TTL clock source
0	1	0	0	Select CLK3 as TTL clock source
1	0	0	0	Select CLK3 and CLK3 as ECL clock sources

[†] Register bits 4, 5, 6, and 7 are *don't care* bits.

[‡] When the clock selection is altered, a minimum 30-ns delay is incurred before the new clocks are stabilized and running.

[§] CLK0 is chosen at power-up to support the VGA pass-through mode.

The internal clock counter is initialized to value 0 any time the output clock-selection register (bits 5, 4, 2, 1) are all set to 1s. This provides a simple mechanism to synchronize multiple video interface palettes, by providing a known phase relationship for the various system clocks. One can write directly to the output clock selection register to cause this to occur, or any of the various resets (POR, hardware, software—see section 1.5) will also cause the appropriate bits to be written and the counters to reset. It is up to the user to provide some means of disabling the dot-clock input to the part while this reset is occurring, if multiple parts are to be synchronized.

Table 2–4. Output Clock Selection Register Format

BITS†						FUNCTION‡
5	4	3	2	1	0	
0	0	0	X	X	X	VCLK frequency = DOTCLK frequency
0	0	1	X	X	X	VCLK frequency = DOTCLK frequency/2
0	1	0	X	X	X	VCLK frequency = DOTCLK frequency/4
0	1	1	X	X	X	VCLK frequency = DOTCLK frequency/8
1	0	0	X	X	X	VCLK frequency = DOTCLK frequency/16
1	0	1	X	X	X	VCLK frequency = DOTCLK frequency/32
1	1	X	X	X	X	VCLK output held at logic high level (default condition)§
X	X	X	0	0	0	SCLK frequency = DOTCLK frequency
X	X	X	0	0	1	SCLK frequency = DOTCLK frequency/2
X	X	X	0	1	0	SCLK frequency = DOTCLK frequency/4
X	X	X	0	1	1	SCLK frequency = DOTCLK frequency/8
X	X	X	1	0	0	SCLK frequency = DOTCLK frequency/16
X	X	X	1	0	1	SCLK frequency = DOTCLK frequency/32
X	X	X	1	1	X	SCLK output held at logic level low (default condition)§

† Register bits 6 and 7 are *don't care* bits.

‡ When the clock selection is altered, a minimum 30-ns delay is incurred before the new clocks are stabilized and running.

§ These lines indicate the power-up conditions required to support the VGA pass-through mode.

**Table 2–5. VCLK/SCLK Divide Ratio Selection
(Output Clock Selection Register Value in Hex)**

SCLK VCLK	BITS 2...0††	divide DOTCLK by					
		000	001	010	011	100	101
		1	2	4	8	16	32
	BITS 5...3††	divide DOTCLK					
000	by 1	00	01	02	03	04	05
001	2	08	09	0A	0B	0C	0D
010	4	10	11	12	13	14	15
011	8	18	19	1A	1B	1C	1D
100	16	20	21	22	23	24	25
101	32	28	29	2A	2B	2C	2D

†† Output clock selection register bits

2.3.1 SCLK

The TLC34075A latches data on the rising edge of the LOAD signal (LOAD is the same as SCLK but is not disabled while the BLANK signal is active). Therefore, SCLK must be set as a function of the pixel bus width and the number of bit planes. The SCLK frequency can be selected to be the same as the dot clock frequency or 1/2, 1/4, 1/8, 1/16, or 1/32 of the dot clock frequency. If SCLK is not used, the output is switched off and held low to protect against VRAM lock-up due to invalid SCLK frequencies. SCLK is also held low during the BLANK signal active period. The control timing has been designed to bring the first pixel data ready from the VRAM when BLANK is disabled and ready for the display. When split shift register transfer operation is used, SCLK is taken care of by working with SSRT input (see Section 2.9).

Refer to Figure 2–2 for the following timing explanation.

The falling edge of VCLK is used internally by the TLC34075A to sample and latch the $\overline{\text{BLANK}}$ input level. When $\overline{\text{BLANK}}$ goes low, SCLK is disabled as soon as possible. In other words, if the last SCLK pulse is at the high level while the sampled $\overline{\text{BLANK}}$ is low, SCLK is allowed to finish its cycle to low level, then SCLK is held low until the sampled $\overline{\text{BLANK}}$ goes back high to enable it again. The VRAM shift register should be updated during the $\overline{\text{BLANK}}$ active period, and the first SCLK pulse is used to clock the first valid pixel data from the VRAM. The internal pipeline delay of the $\overline{\text{BLANK}}$ input is designed to be in phase with data at the DAC output to the monitors. The logic described above works in situations wherein the SCLK period is shorter than, equal to, or longer than the VCLK period.

Figure 2–3 shows the case wherein the SSRT (split shift register transfer) function is enabled. One SCLK pulse with a minimum width of 15 ns is generated from the rising edge at the SFLAG input with specified delay. This is designed to meet the VRAM timing requirement, and this SCLK pulse replaces the first SCLK in the regular shift register transfer case as described above. Refer to Section 2.9 for the detailed explanation of the SSRT function.

The SCLK output waveform may vary at the time that the sampled $\overline{\text{BLANK}}$ input is low. Refer to Appendix C for details.

2.3.2 VCLK

The VCLK frequency can be selected to be 1/1, 1/2, 1/4, 1/8, 1/16, or 1/32 of that of the dot clock, or it can be held at a high logic level. The default condition is for VCLK to be held at a high logic level. VCLK is not used in VGA pass-through mode.

VCLK is used by a GSP or custom-designed control logic to generate control signals ($\overline{\text{BLANK}}$, $\overline{\text{HSYNC}}$, and $\overline{\text{VSYNC}}$). As can be seen from Figures 2–2, 2–3, 2–4, and 2–5, since the control signals are sampled by VCLK, it is obvious that VCLK has to be enabled.

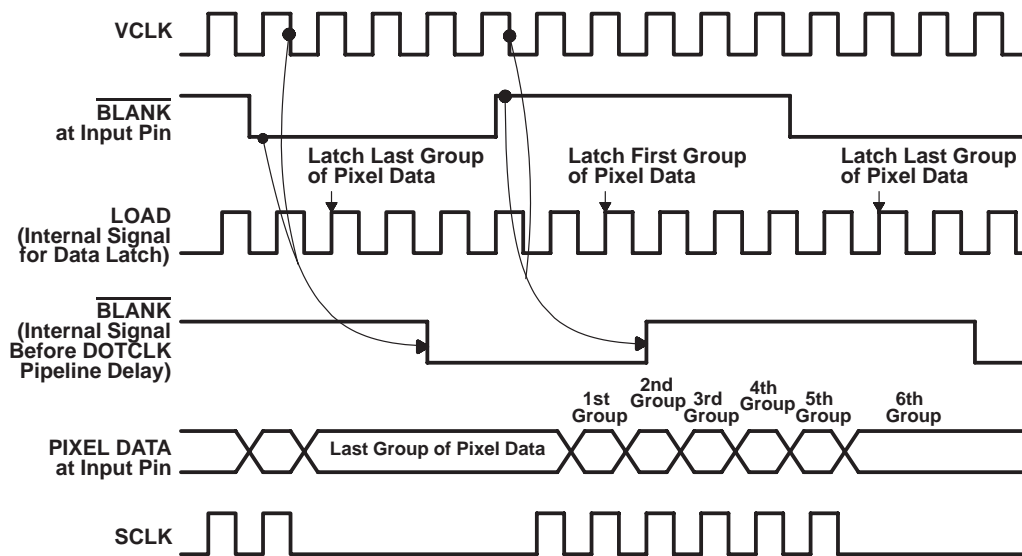

NOTE: Either the SSRT function is disabled (general control register bit 2 = 0), or the SFLAG/NFLAG input is held low if the SSRT function is enabled (general control register bit 2 = 1).

Figure 2–2. SCLK/VCLK Control Timing (SSRT Disabled, SCLK Frequency = VCLK Frequency)

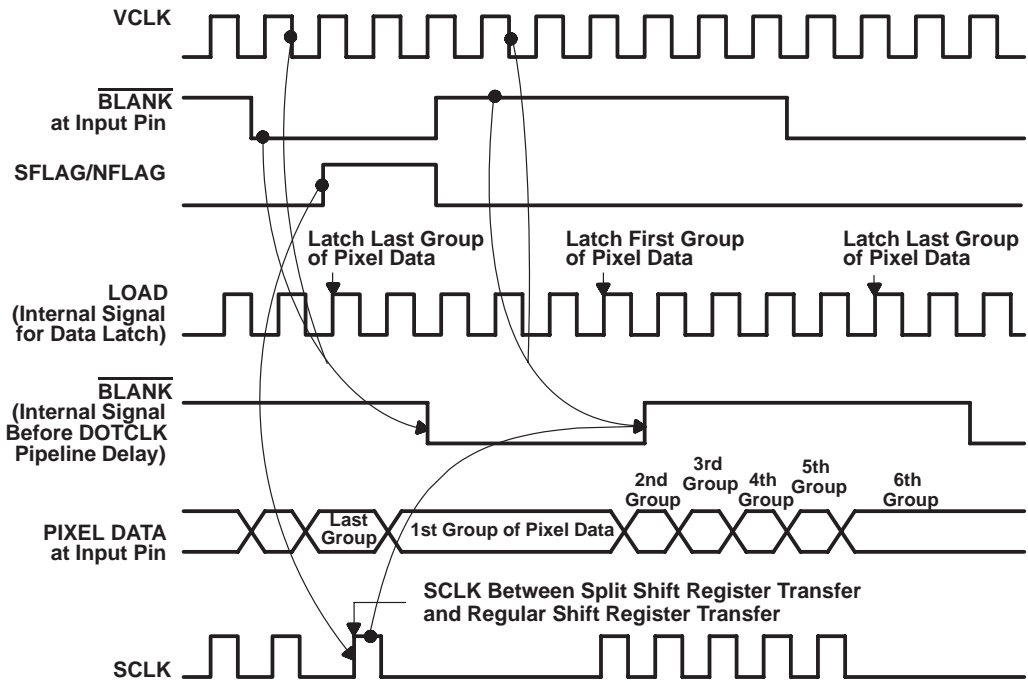

NOTE: The SSRT function is enabled (general control register bit 2 = 1).

Figure 2-3. SCLK/VCLK Control Timing (SSRT Enabled, SCLK Frequency = VCLK Frequency)

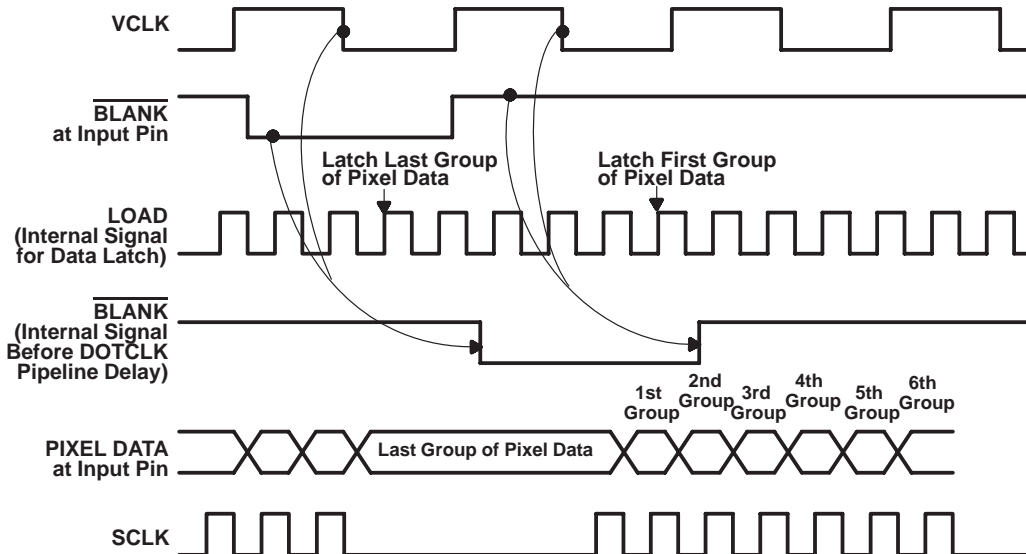

Figure 2-4. SCLK/VCLK Control Timing (SSRT Disabled, SCLK Frequency = 4 × VCLK Frequency)

NOTE: Either the SSRT function is disabled (general control register bit 2 = 0), or the SFLAG/NFLAG input is held low if the SSRT function is enabled (general control register bit 2 = 1).

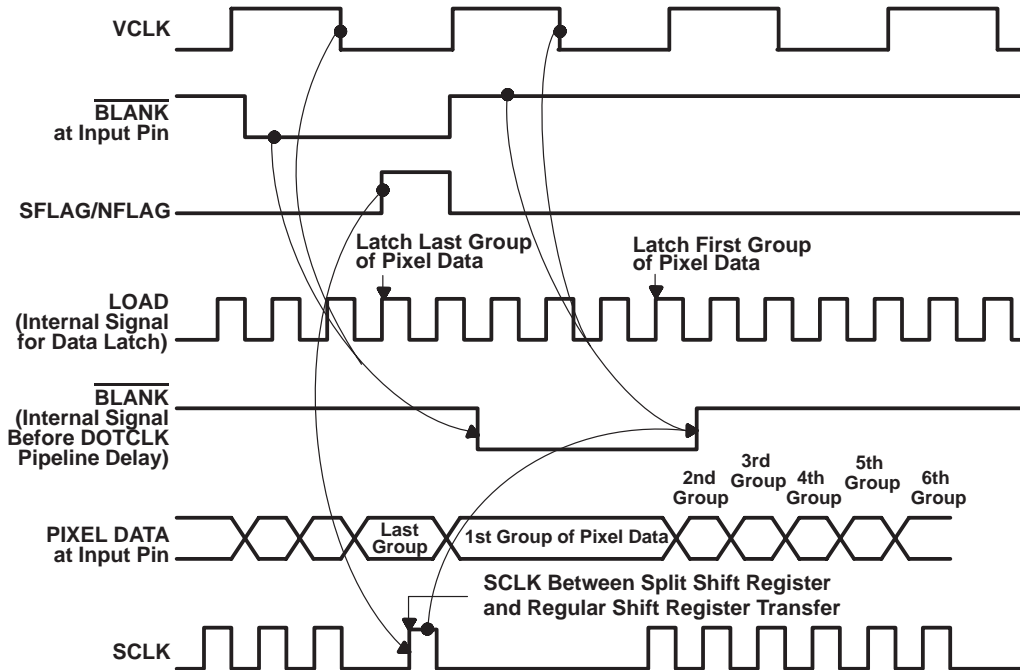

Figure 2–5. SCLK/VCLK Control Timing (SSRT Enabled, SCLK Frequency = 4 × VCLK Frequency)

2.4 Multiplexing Scheme

The TLC34075A offers a highly versatile multiplexing scheme as illustrated in Table 2–6. The on-chip multiplexing allows the system to be reconfigured to the amount of RAM available. For example, if only 256K bytes of memory are available, an 800-by-600 mode with 4 bit planes (four bits per pixel) could be implemented using an 8-bit-wide pixel bus. If, at a later date, another 256K bytes are added to another eight bits of the pixel bus, the user has the option of using 8 bit planes at the same resolution or 4 bit planes at a 1024-by-768 resolution. When an additional 512K bytes is added to the remaining 16 bits of the pixel bus, the user has the option of 8 bit planes at 1024-by-768 or 4 bit planes at 1280 by 1024. All the above can be achieved without any hardware modification and without any increase in the speed of the pixel bus.

2.4.1 VGA Pass-Through Mode

Mode 0, the VGA pass-through mode, is used to emulate the VGA modes of most personal computers. The advantage of this mode is that the TLC34075A can take data presented on the feature connectors of most VGA-compatible PC systems into the device on a separate bus, thus requiring no external multiplexing. This feature is particularly useful for systems in which the existing graphics circuitry is on the motherboard. In this instance, it enables implementation of a drop-in graphics card that maintains compatibility with all existing software by using the on-board VGA circuitry but routing the emerging bit-plane data through the TLC34075A. This is the default mode at power-up. When the VGA pass-through mode is selected after the device is powered up, the clock selection register, the general control register, and the pixel read mask register are set to their default states automatically.

Since this mode is designed with the feature connector philosophy, all the timing is referenced to CLK0, which is used by default for VGA pass-through mode. For all the other normal modes, CLK <0:3> are the oscillator sources for DOTCLK, VCLK, and SCLK; all the data and control timing is referenced to SCLK.

2.4.2 Multiplexing Modes

In addition to the VGA pass-through mode, there are four multiplexing modes available, all of which are referred to as normal modes. In each normal mode, a pixel bus width of 8, 16, or 32 bits may be used. Modes 1, 2, and 3 also support a pixel bus width of 4 bits. Data should always be presented on the least significant bits of the pixel bus. For example, when a 16-bit-wide pixel bus is used and there are 8 bits per pixel, each 8-bit pixel should be presented on P<0:7>. All the unused pixel bus pins should be connected to GND.

Mode 1 uses a single bit plane to address the color palette. The pixel port bit is fed into bit 0 of the palette address, with the 7 high-order address bits being defined by the palette page register (see Section 2.2.3). This mode has uses in high-resolution monochrome applications such as desktop publishing. This mode allows the maximum amount of multiplexing (a 32:1 ratio), thus giving a pixel bus rate of only 4 MHz at a screen resolution of 1280 by 1024. Although only a single bit plane is used, alteration of the palette page register at the line frequency allows 256 different colors to be displayed simultaneously with 2 colors per line.

Mode 2 uses 2 bit planes to address the color palette. The 2 bits are fed into the low-order address bits of the palette with the 6 high-order address bits being defined by the palette page register (see Section 2.2.3). This mode allows a maximum divide ratio of 16:1 on the pixel bus and is a 4-color alternative to mode 1.

Mode 3 uses 4 bit planes to address the color palette. The 4 bits are fed into the low-order address bits of the palette with the 4 high-order address bits being defined by the palette page register (see Section 2.2.3). This mode provides 16 pages of 16 colors and can be used at SCLK divide ratios of 1 to 8.

Mode 4 uses 8 bit planes to address the color palette. Since all 8 bits of palette address are specified from the pixel port, the page register is not used. This mode allows dot-clock-to-SCLK ratios of 1:1 (8-bit bus), 2:1 (16-bit bus) or 4:1 (32-bit bus). Therefore, in a 32-bit configuration, a 1024-by-768 pixel screen can be implemented with an external data rate of only 16 MHz.

2.4.3 True Color Mode

Mode 5 is true color mode, in which 24 bits of data are transferred from the pixel port directly to the DACs with the same amount of pipeline delay as the overlay data and the control signals (BLANK and SYNCs). In this mode, overlay is provided by using the remaining 8 bits of the pixel bus to address the palette RAM, resulting in a 24-bit RAM output that is then used as overlay information to the DACs. When all the overlay inputs (P<0:7>) are at a low logic level or the pixel read mask register is loaded with the value 0, no overlay information is displayed; when a nonzero value is input with the pixel read mask enabled, the color palette RAM is addressed and the resulting data is then fed through to the DACs, receiving priority over the true color data.

The true-color-mode data input only works in the 8-bit mode. In other words, if only 6 bits are used, the 2 MSB inputs for each color should be tied to GND. However, the palette, which is used by the overlay input, is still governed by the 8/6 input pin, and the output MUX selects 8 bits of data or 6 bits of data accordingly.

In the true color mode, P<15:8> pass red data, P<23:16> pass green data, and P<31:24> pass blue data.

2.4.4 Special Nibble Mode

Mode 6 is special nibble mode, which is enabled when the general control register SNM bit (bit 3) is set to 1 and the general control register SSRT bit (bit 2) is set to 0 (see Section 2.11). When special nibble mode is enabled, it takes precedence over the other modes, and the mux control register setup is ignored. The SFLAG/NFLAG input is then used as a nibble flag to indicate which nibble of each byte holds the pixel data. Special nibble mode is a variation of the 4-bit pixel mode with a 16-bit pixel width. All 32 inputs (P0 through P31) are connected as 4 bytes, but the 16-bit data bus is composed of either the lower or upper nibble of each of the 4 bytes. For more detailed information, refer to Section 2.9.2. Since this mode uses 4 bit planes for each pixel, they are fed into the low-order address bits of the palette, with the 4 high-order address bits being defined by the palette page register (see Section 2.2.3).

2.4.5 Multiplex Control Register

The multiplexer is controlled via the 8-bit multiplex control register. The bit fields of the register are in Table 2–6.

Table 2–6. Mode and Bus Width Selection

MODE	MUX CONTROL REGISTER BITS†						DATA BITS PER PIXEL‡	PIXEL BUS WIDTH	SCLK DIVIDE RATIO§	PIXEL LATCHING SEQUENCE¶
	5	4	3	2	1	0				
0#	1	0	1	1	0	1	8	8	1	1) VGA<7:0>
1	0	1	0	0	0	0	1	4	4	1) P<0> 2) P<1> 3) P<2> 4) P<3>
	0	1	0	0	0	1	1	8	8	1) P<0> 2) P<1> ⋮ 8) P<7>
	0	1	0	0	1	0	1	16	16	1) P<0> 2) P<1> ⋮ 16) P<15>
	0	1	0	0	1	1	1	32	32	1) P<0> 2) P<1> ⋮ 32) P<31>
2	0	1	0	1	0	0	2	4	2	1) P<1:0> 2) P<3:2>
	0	1	0	1	0	1	2	8	4	1) P<1:0> 2) P<3:2> 3) P<5:4> 4) P<7:6>
	0	1	0	1	1	0	2	16	8	1) P<1:0> 2) P<3:2> ⋮ 8) P<15:14>
	0	1	0	1	1	1	2	32	16	1) P<1:0> 2) P<3:2> ⋮ 16) P<31:30>
3	0	1	1	0	0	0	4	4	1	1) P<3:0>
	0	1	1	0	0	1	4	8	2	1) P<3:0> 2) P<7:4>
	0	1	1	0	1	0	4	16	4	1) P<3:0> 2) P<7:4> 3) P<11:8> 4) P<15:12>
	0	1	1	0	1	1	4	32	8	1) P<3:0> 2) P<7:4> ⋮ 8) P<31:28>

Table 2–6. Mode and Bus Width Selection (Continued)

MODE	MUX CONTROL REGISTER BITS†						DATA BITS PER PIXEL‡	PIXEL BUS WIDTH	SCLK DIVIDE RATIO§	PIXEL LATCHING SEQUENCE¶
	5	4	3	2	1	0				
4	0	1	1	1	0	0	8	8	1	1) P<7:0>
	0	1	1	1	0	1	8	16	2	1) P<7:0> 2) P<15:8>
	0	1	1	1	1	0	8	32	4	1) P<7:0> 2) P<15:8> 3) P<23:16> 4) P<31:24>
5	0	0	1	1	0	1	24	32	1	1) P<31:8>
6	0	1	1	1	1	1	4	16	4	NFLAG = 0: 1) P<3:0> 2) P<11:8> 3) P<19:16> 4) P<27:24>
										NFLAG = 1: 1) P<7:4> 2) P<15:12> 3) P<23:20> 4) P<31:28>

† Bits 6 and 7 are *don't care* bits.

‡ This is the number of bits of pixel port (or VGA port in mode 1) information used as color data for each displayed pixel, often referred to as the number of bit planes. This may be color palette address data (Modes 0–4 and 6) or DAC data (mode 5).

§ The SCLK divide ratio is the number used for the output clock selection register. It indicates the number of pixels per bus load, or the number of pixels associated with each SCLK pulse. For example, with a 32-bit pixel bus width and 8 bit planes, 4 pixels comprise each bus load. The SCLK divide ratio is not automatically set by mode selection, but must be written to the output clock selection register.

¶ For each operating mode, the pixel latching sequence indicates the sequence in which pixel port or VGA port data are latched into the device. The latching sequence is initiated by a rising edge on SCLK. For modes in which multiple groups of data are latched, the SCLK rising edge latches all the groups, and the pixel clock shifts them out starting with the low-numbered group. For example, in mode 3 with a 16-bit pixel bus width, the rising edge of SCLK latches all the data groups, and the pixel clock shifts them out in the order P<3:0>, P<7:4>, P<11:8>, P<15:12>.

Mode 0 is VGA pass-through mode.

|| Mode 5 is true color mode, in which 24 bits of color information are transferred directly from the pixel port to the DACs; overlay is implemented with the remaining 8 bits of the pixel bus. The distribution of pixel port data to the DACs is as follows: P<31:24> are passed to the blue DAC, P<23:16> are passed to the green DAC, and P<15:8> are passed to the red DAC. P<7:0> are used to generate overlay data; this operation can be disabled by either grounding P<7:0> or by clearing the read mask (see Section 1.4.5).

☆ Mode 6 is special nibble mode, the only mode in which the pixel bus width is not equal to the actual physical width, in bits, of the pixel bus. In this mode, the pixel bus is physically 32 bits wide; depending on the value of SFLAG/NFLAG, either the upper or lower nibble of each of the four physical bytes is selected to comprise the 16 bits of pixel data (equal to four 4-bit pixels).

NOTE: Although leaving unused pins floating will not adversely affect device operation, tying unused pins to ground lowers power consumption and, thus, is recommended.

2.4.5 Multiplex Control Register (Continued)

As an example of how to use Table 2–6, suppose that the design goals specify a system with eight data bits per pixel and the lowest possible SCLK rate. Table 2–6 shows that, for non-VGA-pass-through operation, only mode 4 supports an eight-bit pixel depth. The lowest-possible SCLK rate within mode 4 is 1:4. This set of conditions is selected by writing the value 1Eh to the mux control register. The pixel latching sequence column shows that, in this mode, P<7:0> should be connected to the earliest-displayed pixel plane, followed by P<15:8>, P<23:16>, and then P<31:24> as the last displayed pixel plane. Assuming that VCLK is programmed as DOTCLK/4, Table 2–5 shows that the 1:4 SCLK ratio is selected by writing the value 12h to the output clock selection register. The special nibble mode should also be disabled (see Sections 2.9.2 and 2.11.2).

When the multiplex control register is loaded with 2Dh, the TLC34075A enters the VGA pass-through mode (the same condition as the default power-up mode). Please refer to Section 2.5.4 for more details.

2.4.6 Read Masking

The read mask register is used to enable or disable a pixel address bit from addressing the color palette RAM. Each palette address bit is logically ANDed with the corresponding bit from the read mask register before addressing the palette. This function is performed after the addition of the page register bits and, therefore, a zeroing of the read mask results in one unique palette location (location 0) and is not affected by the palette page register contents.

2.5 Reset

There are 3 ways to reset the TLC34075A:

1. Power-on reset
2. Hardware reset
3. Software reset

The default reset condition is VGA mode, and the values for each register are shown in Section 2.5.4. Note also that, when the TLC34075A is reset, the SCLK and VCLK counters are reset. See Section 2.3.

2.5.1 Power-On Reset

The TLC34075A contains a power-on reset circuit. Once the voltage levels have stabilized following power-on reset, the device is in the VGA pass-through mode.

2.5.2 Hardware Reset

The TLC34075A resets whenever RS<3:0> = HHHH and a rising edge occurs on the \overline{WR} input. The more rising \overline{WR} edges occur, the more reliable the TLC34075A is reset. This scheme (bursting \overline{WR} strobes until the power supply voltage stabilizes) is suggested at power-up if a hardware reset approach is used.

2.5.3 Software Reset

Whenever the mux control register is set for VGA pass-through mode after power-up, all registers are initialized accordingly. Since VGA pass-through mode is the default condition at power-up and hardware reset, the act of selecting the VGA pass-through mode through programming the mux control register is viewed as a software reset. Therefore, whenever mux control register bits <5:0> are set to 2Dh, the TLC34075A initiates a software reset.

2.5.4 VGA Pass-Through Mode Default Conditions

The value contained in each register after hardware or software reset is shown below:

Mux control register:	2Dh
Input clock selection register:	00h
Output clock selection register:	3Fh
Palette page register:	00h

General control register:	03h
Pixel read mask register:	FFh
Palette address register:	xxh
Palette holding register:	xxh
Test register:	(Pointing to color palette red value)

2.6 Frame Buffer Interface

The TLC34075A provides two clock signals for controlling the frame buffer interface: SCLK and VCLK. SCLK can be used to clock out data directly from the VRAM shift registers. Split shift register transfer functionality is also supported. VCLK is used to clock and synchronize control inputs like HSYNC, VSYNC, and BLANK.

The pixel data presented at the inputs is latched at the rising edge of SCLK in normal mode or the rising edge of CLK0 in VGA pass-through mode. Control inputs HSYNC, VSYNC, and BLANK are sampled and latched at the falling edge of VCLK in normal mode, while HSYNC, VSYNC, and VGABLANK are latched at the rising edge of CLK0 in VGA pass-through mode. Both data and control signals are lined up at the DAC outputs to the monitors through the internal pipeline delay, so external glue logic is not required. The outputs of the DACs are capable of directly driving a 37.5- Ω load, as in the case of a doubly terminated 75- Ω cable. See Figures 2-7 and 2-8 for nominal output levels.

2.7 Analog Output Specifications

The DAC outputs are controlled by current sources (three for IOG and two each for IOR and IOB) as shown in Figure 2-6. In the normal case, there is a 7.5-IRE difference between blank and black levels, which is shown in Figure 2-7. If a 0-IRE pedestal is desired, it can be selected by resetting bit 4 of the general control register (see Section 2.11.3). The video output for a 0-IRE pedestal is shown in Figure 2-8.

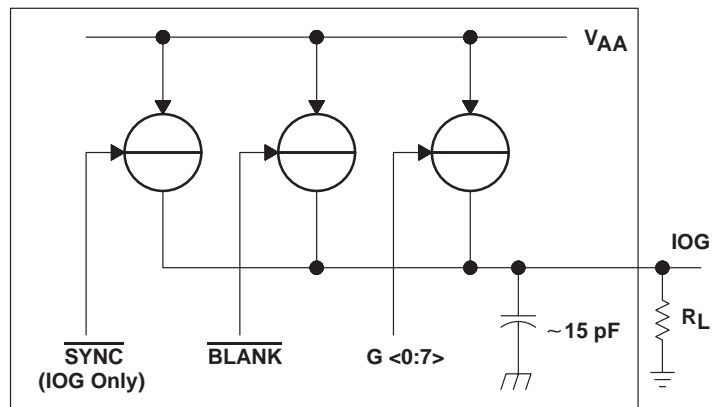

Figure 2-6. Equivalent Circuit of the IOG Current Output

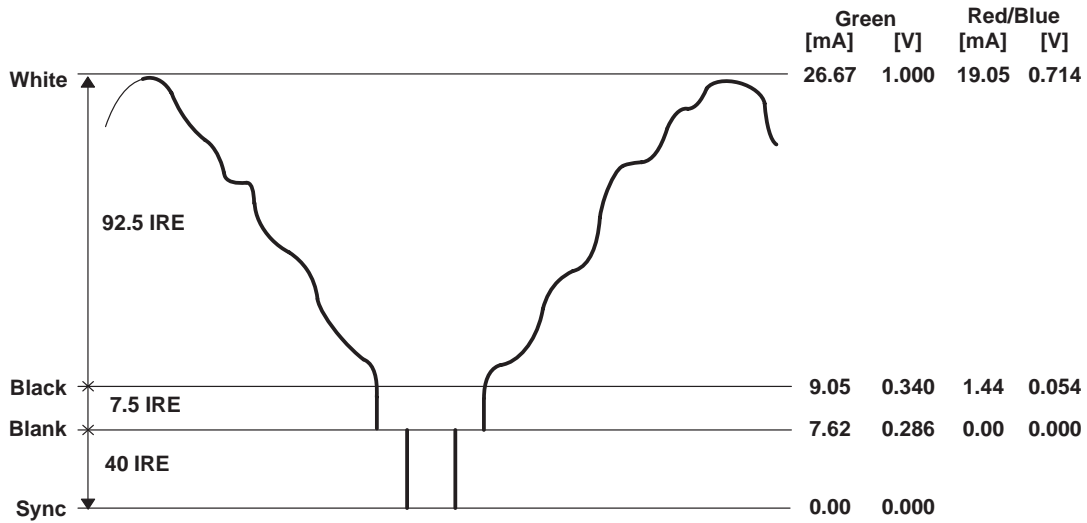

Figure 2-7. 7.5-IRE, 8-Bit Composite Video Output

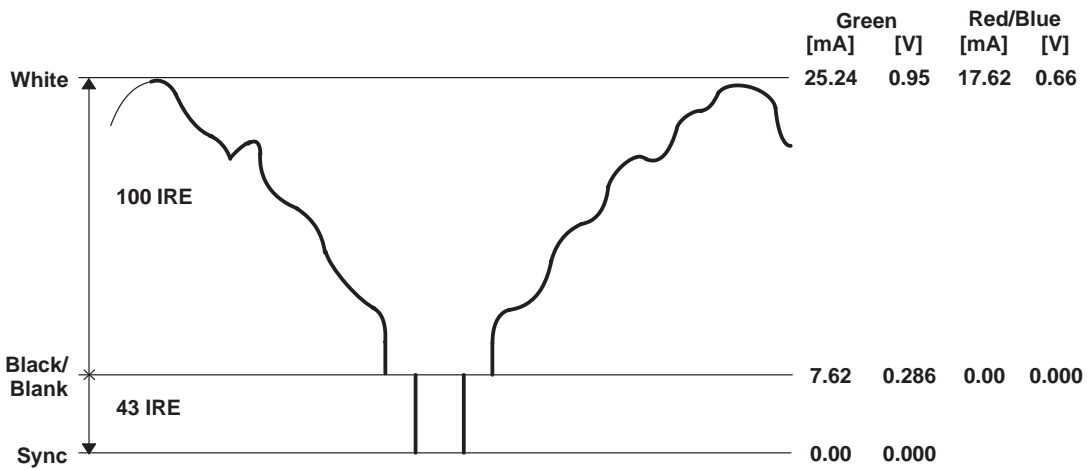

Figure 2-8. 0-IRE, 8-Bit Composite Video Output

NOTE: 75-Ω doubly terminated load. $V_{REF} = 1.235\text{ V}$, $R_{SET} = 523\ \Omega$. RS-343A levels and tolerances are assumed.

2.7 Analog Output Specifications (Continued)

A resistor (R_{SET}) is needed to connect the FS ADJ pin to GND to control the magnitude of the full-scale video signal. The IRE relationships in Figures 2-7 and 2-8 are maintained regardless of the full-scale output current.

The relationship between R_{SET} and the full-scale output current IOG is:

$$R_{SET} (\Omega) = K1 \times V_{REF} (V) / IOG (mA)$$

The full-scale output current on IOR and IOB for a given R_{SET} is:

$$IOR, IOB (mA) = K2 \times V_{REF} (V) / R_{SET} (\Omega)$$

where K1 and K2 are defined as:

PEDESTAL	IOG		IOR, IOB	
	8-BIT OUTPUT	6-BIT OUTPUT	8-BIT OUTPUT	6-BIT OUTPUT
7.5-IRE	K1 = 11,294	K1 = 11,206	K2 = 8,067	K2 = 7,979
0-IRE	K1 = 10,684	K1 = 10,600	K2 = 7,462	K2 = 7,374

2.8 \overline{HSYNC} , \overline{VSYNC} , and \overline{BLANK}

For the normal modes, \overline{HSYNC} and \overline{VSYNC} are active-low pulses, and they are passed through true/complement gates to the HSYNCOUT and VSYNCOUT outputs. The output polarities of HSYNCOUT and VSYNCOUT can be programmed through the general control register. However, for the VGA pass-through mode, the polarities needed for monitors are already provided at the feature connector from which \overline{HSYNC} and \overline{VSYNC} are sourced, so the TLC34075A just passes \overline{HSYNC} and \overline{VSYNC} through to HSYNCOUT and VSYNCOUT without polarity change. As described in Section 2.3 and Figures 2–2 through 2–5, the \overline{BLANK} , \overline{HSYNC} , and \overline{VSYNC} inputs are sampled and latched on the falling edge of VCLK in the normal modes, and they are latched on the rising edge of the CLK0 input in the VGA pass-through mode. Refer to Figure 3–2 for the detailed timing.

The \overline{HSYNC} and \overline{VSYNC} inputs are used for both the VGA pass-through and normal modes. If the application uses both VGA pass-through and normal modes, an external multiplexer is needed to select \overline{HSYNC} and \overline{VSYNC} between VGA pass-through mode and normal mode. The \overline{MUXOUT} signal is designed for this purpose (see Sections 2.10 and 2.11).

The \overline{HSYNC} , \overline{VSYNC} , and \overline{BLANK} signals have internal pipeline delays to align the data at the outputs. Due to the sample and latch timing delay, it is possible to have active SCLK pulses after the \overline{BLANK} input becomes active. The relationship between VCLK and SCLK and the internal VCLK sample and latch delay need to be carefully reviewed and programmed. See Section 2.3 and Figures 2–2 and 2–3 for more details.

As shown in Figure 2–6 for the IOG DAC output, active \overline{HSYNC} and \overline{VSYNC} signals turn off the sync current source (after the pipeline delay) independent of the \overline{BLANK} signal level. In real applications, \overline{HSYNC} and \overline{VSYNC} should only be active (low) when \overline{BLANK} is active (low).

To alter the polarity of the HSYNCOUT and VSYNCOUT outputs in the normal modes, the MPU must set or clear the corresponding bits in the general control register (see Section 2.11.1). Again, these two bits affect only the normal modes, not the VGA pass-through mode. These bits default to 1.

2.9 Split Shift Register Transfer VRAMs and Special Nibble Mode

2.9.1 Split Shift Register Transfer VRAMs

The TLC34075A directly supports split shift register transfer (SSRT) VRAMs. In order to allow the VRAMs to perform a split shift register transfer, an extra SCLK cycle must be inserted during the blank sequence. This is initiated when the SSRT enable bit (bit 2 in the general control register) is set to 1, the SNM bit (bit 3 in the general control register) is reset to 0 (see Section 2.11), and a rising edge on the SFLAG/NFLAG input pin is detected. An SCLK pulse is generated within 20 ns of the rising edge of the SFLAG/NFLAG signal. A minimum 15-ns high logic level duration is provided to satisfy all of the –15 VRAM requirements. By controlling the SFLAG/NFLAG rise time, the delay time from the rising edge of the VRAM TRG signal to SCLK can be satisfied. The relationship between the SCLK, SFLAG/NFLAG, and \overline{BLANK} signals is as follows:

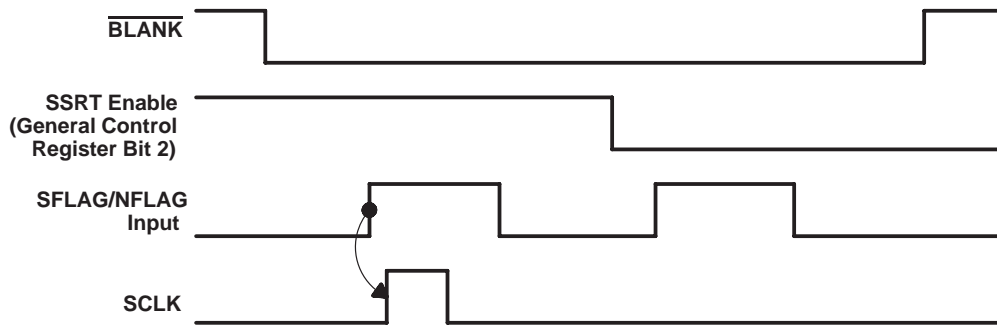

Figure 2–9. Relationship Between SFLAG/NFLAG, $\overline{\text{BLANK}}$, and SCLK

If SFLAG/NFLAG is designed as an R-S latch set by split shift register transfer timing and reset by $\overline{\text{BLANK}}$ going high, the delay from $\overline{\text{BLANK}}$ high to SFLAG/NFLAG low cannot exceed one-half of one SCLK cycle; otherwise, the SCLK generation logic may fail.

If the SSRT function is enabled but SFLAG/NFLAG is held low, SCLK runs as if the SSRT function is disabled. The SFLAG/NFLAG input is not qualified by the $\overline{\text{BLANK}}$ signal and needs to be held low whenever an SSRT SCLK pulse is not desired. Refer to Section 2.3.1 and Figures 2–2 through 2–8 for more system details.

2.9.2 Special Nibble Mode

Special nibble mode is enabled when the SNM bit (bit 3 in the general control register) is set to 1 and the SSRT bit (bit 2 in the general control register) is reset to 0 (see Section 2.11). Special nibble mode provides a variation of the 4-bit pixel mode with a 16-bit bus width. While all 32 inputs ($P<0:31>$) are connected as 4 bytes, the 16-bit data bus is composed of the lower or upper nibble of each of the 4 bytes, depending on the level of the SFLAG/NFLAG input. The pixel data is distributed to 16-bit data bus as shown in Table 2–7.

Table 2–7. Pixel Data Distribution in Special Nibble Mode

SNM BIT = 1, SSRT BIT = 0	
SFLAG/NFLAG = 1	SFLAG/NFLAG = 0
P<7:4>	P<3:0>
P<15:12>	P<11:8>
P<23:20>	P<19:16>
P<31:28>	P<27:24>

The SFLAG/NFLAG value is not latched by the TLC34075A. Therefore, it should stay at the same level during the whole active display period, changing levels only during the $\overline{\text{BLANK}}$ signal active time. Refer to Figure 2–10, which is similar to Figure 2–2 except that the $\overline{\text{BLANK}}$ signal timing reference to SFLAG/NFLAG is explained. The SFLAG/NFLAG input has to meet the setup time and hold the data long enough to ensure that no pixel data is missed.

Special nibble mode operates at the line frequency when $\overline{\text{BLANK}}$ is active. However, the typical application of this mode is double frame buffers with pixel data width of 4 bits. While one frame buffer is being displayed on the monitor, the other frame buffer can be used to accept new picture information. SFLAG/NFLAG is used to indicate which frame buffer is being displayed.

SNM and SSRT must be mutually exclusive. Unpredictable operation occurs if both the SNM and SSRT bits are set to 1. The mux control register should be set up as shown in Table 2–6 (see Section 2.4.5). However, the SNM bit takes precedence over the other mux control register selections. In other words, if the mux control register is set up for another mode but special nibble mode is still enabled in the general control register, the input multiplex circuit takes whatever SCLK divide ratio the mux control register specifies and performs the nibble operation, causing operational failure.

During special nibble mode, the input mux circuit latches all 8-bit inputs but only passes on the specified nibble. The specified nibble is stored in the 4 LSBs of the next register pipe after the input latch, and the 4 MSBs are zeroed in that register. The register pipe contents are then passed to the read mask block. With this structure, the palette page register still functions normally, providing good flexibility to users.

If the general control register bit 3 = 0 and bit 2 = 0, both split shift register transfers and special nibble mode are disabled and the SFLAG/NFLAG input is ignored.

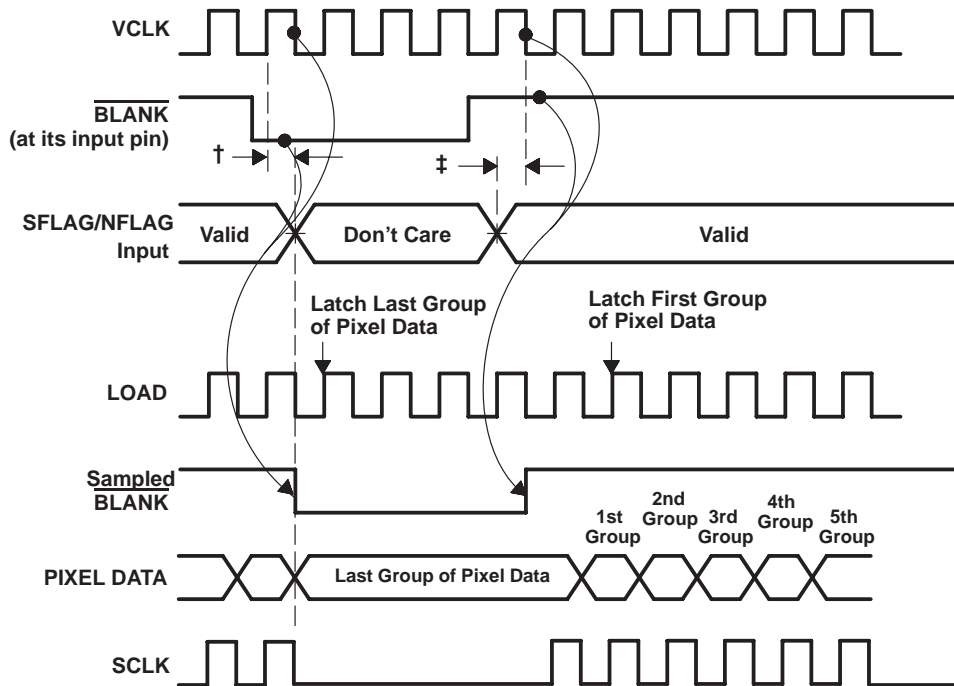

- † CAUTION:
If the data is not held valid until SCLK and $\overline{\text{BLANK}}$ both go low, the last few pixels could be missed.
- ‡ Setup time to next VCLK falling edge after $\overline{\text{BLANK}}$ high (must be met, otherwise the first pixel data could be missed).

Figure 2–10. SFLAG/NFLAG Timing in Special Nibble Mode

2.10 MUXOUT Output

$\overline{\text{MUXOUT}}$ is a TTL-compatible output. It is software programmable and is used to control external devices. Its typical application is to select the $\overline{\text{HSYNC}}$ and $\overline{\text{VSYNC}}$ inputs between the VGA pass-through mode and the normal modes (see Section 2.8). This output is driven low at power-up or when VGA pass-through mode is selected; at any other time it can be programmed to the desired polarity via general control register bit 7.

2.11 General Control Register

The general control register is used to control HSYNC and VSYNC polarity, split shift register transfer enabling, special nibble mode, sync control, the ones accumulation clock source, and the VGA pass-through indicator. The bit field definitions are as follows:

Table 2–8. General Control Register Bit Functions

GENERAL CONTROL REGISTER BIT								FUNCTION
7	6	5	4	3	2	1	0	
X	X	X	X	X	X	X	0	HSYNCOUT is active-low
X	X	X	X	X	X	X	1	HSYNCOUT is active-high (default)
X	X	X	X	X	X	0	X	VSYNCOUT is active-low
X	X	X	X	X	X	1	X	VSYNCOUT is active-high (default)
X	X	X	X	X	0	X	X	Disable split shift register transfer (default)
X	X	X	X	0	1	X	X	Enable split shift register transfer
X	X	X	X	0	X	X	X	Disable special nibble mode (default)
X	X	X	X	1	0	X	X	Enable special nibble mode
X	X	X	0	X	X	X	X	0-IRE pedestal (default)
X	X	X	1	X	X	X	X	7.5-IRE pedestal
X	X	0	X	X	X	X	X	Disable sync (default)
X	X	1	X	X	X	X	X	Enable sync
X	0	X	X	X	X	X	X	Reserved (default)
X	1	X	X	X	X	X	X	Reserved
0	X	X	X	X	X	X	X	MUXOUT is low (default)
1	X	X	X	X	X	X	X	MUXOUT is high

2.11.1 HSYNCOUT and VSYNCOUT (Bits 0 and 1)

HSYNCOUT and VSYNCOUT polarity inversion is provided to allow indication to monitors of the current screen resolution. Since the polarities for VGA pass-through mode are provided at the feature connector, the inputs to the TLC34075A will have the right polarities for monitors already, so the TLC34075A just passes them through with pipeline delay (see Section 2.8). These two bits only work in the normal modes, and the input horizontal and vertical syncs are assumed to be active-low incoming pulses. These two bits default to the value 1 but can be changed by software.

2.11.2 Split Shift Register Transfer Enable (SSRT) and Special Nibble Mode Enable (SNM) (Bits 2 and 3)

See Section 2.9.

2.11.3 Pedestal Enable Control (Bit 4)

This bit specifies whether a 0- or 7.5-IRE blanking pedestal is to be generated on the video outputs. Having a 0-IRE blanking pedestal means that the black and blank levels are the same.

0: 0-IRE pedestal (default)

1: 7.5-IRE pedestal

2.11.4 Sync Enable Control (Bit 5)

This bit specifies whether or not SYNC information is to be output onto IOG.

0: Disable sync (default)

1: Enable sync

2.11.5 MUXOUT (Bit 7)

The MUXOUT bit indicates to external circuitry that the device is running in VGA pass-through mode. This bit does not affect the operation of the device (see Section 2.10).

0: $\overline{\text{MUXOUT}}$ is low (default in VGA pass-through mode)

1: MUXOUT is high

2.12 Test Register

There are three test functions provided in the TLC34075A, and they are all controlled and monitored through the test register. They are data flow check, DAC analog test, and screen integrity test.

The test register has two ports: one for a control word, accessed by writing to the register location, and one for the data word, accessed by reading from the register location. Depending on the channel written in the control word, the data read presents the information for that channel.

The control word is three bits long and occupies D<2:0>. It specifies which of the eight channels to inspect. The following table and state machine diagrams show how each channel is addressed:

Table 2–9. Test Mode Selection

D2	D1	D0	CHANNEL
0	0	0	Color palette red value
0	0	1	Color palette green value
0	1	0	Color palette blue value
0	1	1	Identification code
1	0	0	Ones accumulation red value
1	0	1	Ones accumulation green value
1	1	0	Ones accumulation blue value
1	1	1	Analog test

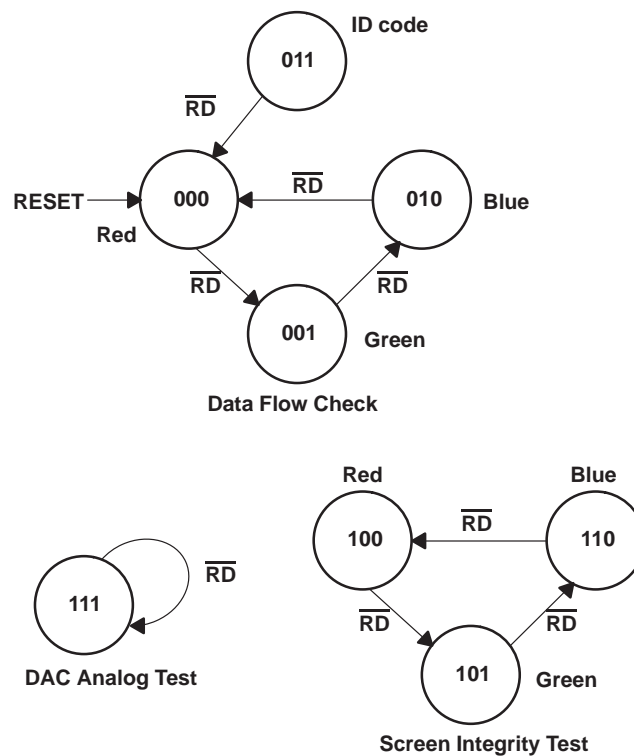

Figure 2–11. Test Register Control Word State Diagrams

2.12.1 Frame Buffer Data Flow Test

The TLC34075A provides a means to check all the data entering the DAC (but before the output multiplexer 8/6 shift). When accessing these color channels, the data entering the DACs should be kept constant for the entire MPU read cycle. This can be done either by slowing down the dot clock or ensuring that the data is constant for a sufficiently long series of pixels. The value read is the one stored in the color palette RAM location pointed to by the input multiplexer. The read operation causes a post-increment to point to the next color channel, and the post-increment of blue wraps back to red as shown in the preceding state diagram. For example, if D<2:0> is written as 001, then three successive reads are performed, the values read out are green, blue, and red in that sequence.

2.12.2 Identification Code

The ID code can be used for identification of different software versions. The ID code in the TLC34075A is static and may be read without consideration of the dot clock or video signals. To be user-friendly, the read postincrement also applies to the ID register, but once it falls into the color channel, it will not come back pointing to the ID unless the value 011 is written to D<2:0> again. So, if the test register is written as 011 in D<2:0>, then six successive reads are performed, the first value read is the ID and the last value read is green. The ID value defined here is 75h.

2.12.3 Ones Accumulation Screen Integrity Test

A technique called ones accumulation can be used to detect errors in fixed (not animated) screen displays. This type of error detection is useful for system checkout and field diagnostics.

Each of the 256 24-bit words in the TLC34075A internal color palette RAM is composed of three bytes, one each for the red, green, and blue components of the word. When D<2:0> are programmed with the appropriate binary value (see Table 2–9), the TLC34075A monitors the corresponding color byte that is output by the color palette RAM. For example, if D<2:0> are programmed with the value 100, the TLC34075A monitors the red byte. As the current frame is scanned, for each color palette RAM word accessed, the designated color byte is checked to see how many “1” bits it contains, and this number is added to a temporary accumulator (the entire byte is checked, even if 6-bit mode is selected). For example, if the designated color byte contains the value 41h (0100 0001), then the value 2 is added to the temporary accumulator, as 41h contains two “1” bits. This process is continued until an entire frame has been scanned; the same color byte is monitored for the entire frame. The temporary accumulator truncates any overflow above the value 255. Due to circuit speed limitations, the ones accumulation is calculated at a speed of (DOTCLK frequency)/2. During the vertical retrace activated by a falling edge on the TLC34075A VSYNC input, the value in the temporary accumulator is transferred into the ones accumulation register, and then the temporary accumulator is reset to zero (NOTE: the ones accumulation register is updated only on the falling edge of VSYNC, not by any vertical sync pulses coded into the composite video signal). Before the next frame scan begins, the TLC34075A automatically changes the value in D<2:0> so that the ones accumulation performed during the next frame scan is for a different color byte (see the screen integrity test state diagram of Figure 2–11). As long as the screen display remains fixed, the ones accumulation value for a particular color byte should not change; if it does, an error has occurred.

2.12.4 Analog Test

Analog test is used to compare the voltage amplitudes of the analog RGB outputs to each other and to a 145-mV reference. This enables the MPU to determine whether the CRT monitor is connected to the analog RGB outputs or not and whether the DACs are functional. To perform an analog test, D<2:0> must be set to 111; D<7:4> are set as shown in Table 2–11. D<3> contains the result of the analog test.

The result of the analog comparison is strobed into D3 at the falling edge of an internal signal derived from the input BLANK signal. In order to have stable inputs to the comparator, the DAC should be set to a constant level between syncs. For normal operation, data flow check, and screen integrity test, D<7:4> must be set to zero.

Table 2–10. Test Register Bit Definitions for Analog Test

BIT DEFINITION	READ/WRITE
D7: Red select	R/W
D6: Green select	R/W
D5: Blue select	R/W
D4: 145-mV reference select	R/W
D3: Result	R

Table 2–11. D<7:4> Bit Coding for Analog Comparisons

D<7:4>	OPERATION	IF D3 = 1	IF D3 = 0
0000	Normal operation	Don't care	Don't care
1010	Red DAC compared to blue DAC	Red > blue	Red < blue
1001	Red DAC compared to 145-mV reference	Red > 145 mV	Red < 145 mV
0110	Green DAC compared to blue DAC	Green > blue	Green < blue
0101	Green DAC compared to 145-mV reference	Green > 145 mV	Green < 145 mV

NOTE: All the outputs have to be terminated to compare the voltage.

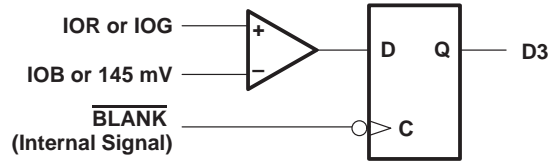

Figure 2–12. Internal Comparator Circuitry for Analog Test

3 Specifications

3.1 Absolute Maximum Ratings Over Operating Free-Air Temperature Range (Unless Otherwise Noted)[†]

Supply voltage, V_{DD} (see Note 1)	7 V
Input voltage range, V_I	-0.5 V to $V_{DD} + 0.5$ V
Analog output short-circuit duration to any power supply or common	unlimited
Operating free-air temperature range, T_A	0°C to 70°C
Storage temperature range	-65°C to 150°C
Junction temperature	175°C
Case temperature for 10 seconds: FN package	260°C
Lead temperature 1,6 mm (1/16 inch) from case for 10 seconds	260°C

[†] Stresses beyond those listed under “absolute maximum ratings” may cause permanent damage to the device. These are stress ratings only and functional operation of the device at these or any other conditions beyond those indicated under “recommended operating conditions” is not implied. Exposure to absolute-maximum-rated conditions for extended periods may affect device reliability.

NOTE 1: All voltage values are with respect to the GND terminal.

3.2 Recommended Operating Conditions

	MIN	NOM	MAX	UNIT
V_{DD} Supply voltage	4.75	5	5.25	V
V_{REF} Reference voltage	1.15	1.235	1.26	V
V_{IH} High-level input voltage	2.4		$V_{DD} + 0.5$	V
V_{IL} Low-level input voltage			0.8	V
Output load resistance, R_L		37.5		Ω
FS ADJUST resistor, R_{SET}		523		Ω
Operating free-air temperature	0		70	°C

3.3 Electrical Characteristics

PARAMETER		TEST CONDITIONS	MIN	TYP [†]	MAX	UNIT
V _{OH}	High-level output voltage	I _{OH} = -800 μA	2.4			V
V _{OL}	Low-level output voltage	D<0:7>, MUXOUT, VCLK	I _{OL} = 3.2 mA		0.4	V
		HSYNCOUT, VSYNCOUT	I _{OL} = 15 mA		0.4	
		SCLK	I _{OL} = 18 mA		0.4	
I _{IH}	High-level input current	TTL inputs	V _I = 2.4 V		1	μA
		ECL inputs	V _I = 4 V		1	
I _{IL}	Low-level input current	TTL inputs	V _I = 0.8 V		-1	μA
		ECL inputs	V _I = 0.4 V		-1	
I _{DD}	Supply current, pseudo-color mode	TLC34075A-66	See Note 2		425	mA
		TLC34075A-85		450		
		TLC34075A-110		475		
		TLC34075A-135		535		
I _{DD}	Supply current, true color mode	TLC34075A-66		475		
		TLC34075A-85		475		
		TLC34075A-110		475		
		TLC34075A-135		475		
I _{OZ}	High-impedance-state output current				10	μA
C _i	Input capacitance	TTL inputs	f = 1 MHz, V _I = 2.4 V		4	pF
		ECL inputs	f = 1 MHz, V _I = 4 V		4	

[†] All typical values are at V_{DD} = 5 V, T_A = 25°C.

NOTE 2: I_{DD} is measured with DOTCLK running at the maximum specified frequency, SCLK frequency = DOTCLK frequency/4, and the palette RAM loaded with full-range toggling patterns (00h/00h/FFh/FFh/00h/00h/FFh/FFh/ . . .). Pseudo-color mode is also known as color indexing mode.

3.4 Operating Characteristics

PARAMETER	TEST CONDITIONS	MIN	TYP	MAX	UNIT
Resolution (each DAC)	8/6 high		8		bits
	8/6 low		6		
E _L End-point linearity error (each DAC)	8/6 high			1	LSB
	8/6 low			1/4	
E _D Differential linearity error (each DAC)	8/6 high			1	LSB
	8/6 low			1/4	
Gray scale error				5%	
Output current (see Note 4)	White level relative to blank	17.69	19.05	20.4	mA
	White level relative to black (7.5 IRE only)	16.74	17.62	18.5	
	Black level relative to blank (7.5 IRE only)	0.95	1.44	1.9	
	Blank level on IOR, IOB	0	5	50	μA
	Blank level on IOG (with SYNC enabled)	6.29	7.6	8.96	mA
	Sync level on IOG (with SYNC enabled)	0	5	50	μA
	One LSB (8/6 high)		69.1		μA
	One LSB (8/6 low)		276.4		
DAC-to-DAC matching			2%	5%	
DAC-to-DAC crosstalk			-20		dB
V _{oc} Output compliance		-1		1.2	V
V _{ref} Voltage reference output voltage		1.15	1.235	1.26	V
Output impedance			50		kΩ
Output capacitance	f = 1 MHz, I _{OUT} = 0		13		pF
Clock and data feedthrough			-20		dB
Glitch impulse (see Note 3)			50		pV-s
Pipeline delay	Normal mode		1 SCLK + 9 DOTCLK		periods
	VGA pass-through mode		7.5 DOTCLK		

NOTES: 3. Glitch impulse does not include clock and data feedthrough. The -3-dB test bandwidth is twice the clock rate.

4. Test conditions for RS343-A video signals (unless otherwise specified): Recommended Operating Conditions, using external voltage reference V_{REF} = 1.235 V, RSET = 523 Ω. When using the internal voltage reference, RSET may need to be adjusted in order to meet these limits.

3.5 Timing Requirements (see Note 5)

PARAMETER		TLC34075A -66		TLC34075A -85		TLC34075A -110		TLC34075A -135		UNIT
		MIN	MAX	MIN	MAX	MIN	MAX	MIN	MAX	
DOTCLK frequency		66		85		110		135		MHz
CLK0 frequency for VGA pass-through mode (see Note 6)		66		85		85		85		MHz
t _{cyc}	Clock cycle time	TTL	15.2	11.8	9.1	7.4			ns	
		ECL	15.2	11.8	9.1	7.4				
t _{su1}	Setup time, RS<0:3> valid before RD or WR ↓	10		10		10		10		ns
t _{h1}	Hold time, RS<0:3> valid after RD or WR ↓	10		10		10		10		ns
t _{su2}	Setup time, D<0:7> valid before WR ↑	35		35		35		35		ns
t _{h2}	Hold time, D<0:7> valid after WR ↑	0		0		0		0		ns
t _{su3}	Setup time, VGA<0:7> and HSYNC, VSYNC, and VGABLANK valid before CLK0 ↑	2		2		2		2		ns
t _{h3}	Hold time, VGA<0:7> and HSYNC, VSYNC, and VGABLANK valid after CLK0 ↑	2		2		2		2		ns
t _{su4}	Setup time, P<0:31> valid before SCLK ↑	2		2		2		0		ns
t _{h4}	Hold time, P<0:31> valid after SCLK ↑	5		5		5		5		ns
t _{su5}	Setup time, HSYNC, VSYNC, and BLANK valid before VCLK ↓	5		5		5		5		ns
t _{h5}	Hold time, HSYNC, VSYNC, and BLANK valid after VCLK ↓	2		2		2		2		ns
t _{w1}	Pulse duration, RD or WR low	50		50		50		50		ns
t _{w2}	Pulse duration, RD or WR high	30		30		30		30		ns
t _{w3}	Pulse duration, clock high	TTL	4.5	4	3.5	3			ns	
		ECL	5.5	4	3.5	3				
t _{w4}	Pulse duration, clock low	TTL	4.5	4	3.5	3			ns	
		ECL	5.5	4	3.5	3				
t _{w5}	Pulse duration, SFLAG/NFLAG high (see Note 7)	30		30		30		30		ns

NOTES: 5. TTL input signals are 0 to 3 V with less than 3 ns rise/fall time between the 10% and 90% levels unless otherwise specified. ECL input signals are $V_{DD}-1.8\text{ V}$ to $V_{DD}-0.8\text{ V}$ with less than 2 ns rise/fall time between the 20% and 80% levels. For input and output signals, timing reference points are at the 10% and 90% signal levels. Analog output loads are less than 10 pF. D<0:7> output loads are less than 50 pF. All other output loads are less than 50 pF unless otherwise specified.

6. In VGA mode, CLK0 minimum pulse duration for clock low should be greater than 4.8 ns.

7. This parameter applies when the split shift register transfer (SSRT) function is enabled. See Section 2.9.1 for details.

3.6 Switching Characteristics

PARAMETER	TLC34075A-66			TLC34075A-85			UNIT
	MIN	TYP	MAX	MIN	TYP	MAX	
SCLK frequency (see Note 8)			66			85	MHz
VCLK frequency			66			85	MHz
t _{en1}	Enable time, RD low to D<0:7> valid			40			ns
t _{dis1}	Disable time, RD high to D<0:7> disabled			17			ns
t _{v1}	Valid time, D<0:7> valid after RD high			5		5	ns
t _{PLH1}	Propagation delay, SFLAG/NFLAG ↑ to SCLK high (see Note 9)			0		20	ns
t _{d1}	Delay time, RD low to D<0:7> starting to turn on			5		5	ns
t _{d2}	Delay time, selected input clock high/low to DOTCLK (internal signal) high/low				7		ns
t _{d3}	Delay time, DOTCLK high/low to VCLK high/low				6		ns
t _{d4}	Delay time, VCLK high/low to SCLK high/low			0		5	ns
t _{d5}	Delay time, DOTCLK high/low to SCLK high/low				8		ns
t _{d6}	Delay time, DOTCLK high to IOR/IOG/IOB active (analog output delay time) (see Note 10)				20		ns
t _{d7}	Analog output settling time (see Note 11)				8		ns
t _{d8}	Delay time, DOTCLK high to HSYNCOOUT and VSYNCOOUT valid				5		ns
t _{w6}	Pulse duration, SCLK high (see Note 9)			15		55	ns
t _r	Analog output rise time (see Note 12)				2		ns
	Analog output skew			0		2	ns

NOTES: 8. SCLK can drive an output capacitive load up to 60 pF. The worst-case transition time between the 10% and 90% levels is less than 4 ns.

9. This parameter applies when the split shift register transfer (SSRT) function is enabled. See Section 2.9.1 for details.

10. Measured from the 90% point of the rising edge of DOTCLK to 50% of the full-scale transition.

11. Measured from the 50% point of the full-scale transition to the point at which the output has settled, within ± 1 LSB (settling time does not include clock and data feedthrough).

12. Measured between 10% and 90% of the full-scale transition.

3.6 Switching Characteristics (Continued)

PARAMETER	TLC34075A-110			TLC34075A-135			UNIT	
	MIN	TYP	MAX	MIN	TYP	MAX		
SCLK frequency (see Note 13)			85			85	MHz	
VCLK frequency			85			85	MHz	
t _{en1}	Enable time, RD low to D<0:7> valid		40			40	ns	
t _{dis1}	Disable time, RD high to D<0:7> disabled		17			17	ns	
t _{v1}	Valid time, D<0:7> valid after RD high		5			5	ns	
t _{PLH1}	Propagation delay, SFLAG/NFLAG ↑ to SCLK high (see Note 14)		0		20	0	20	ns
t _{d1}	Delay time, RD low to D<0:7> starting to turn on		5			5	ns	
t _{d2}	Delay time, selected input clock high/low to DOTCLK (internal signal) high/low			7		7	ns	
t _{d3}	Delay time, DOTCLK high/low to VCLK high/low			6		6	ns	
t _{d4}	Delay time, VCLK high/low to SCLK high/low		0		5	0	5	ns
t _{d5}	Delay time, DOTCLK high/low to SCLK high/low			8		8	ns	
t _{d6}	Delay time, DOTCLK high to IOR/IOG/IOB active (analog output delay time) (see Note 15)			20		20	ns	
t _{d7}	Analog output settling time (see Note 16)			6		6	ns	
t _{d8}	Delay time, DOTCLK high to HSYNCOUT and VSYNCOUT valid			3		3	ns	
t _{w6}	Pulse duration, SCLK high (see Note 14)		15		55	15	55	ns
t _r	Analog output rise time (see Note 17)			2		2	ns	
	Analog output skew		0		2	0	2	ns

NOTES: 13. SCLK can drive an output capacitive load up to 60 pF. The worst-case transition time between the 10% and 90% levels is less than 4 ns.

14. This parameter applies when the split shift register transfer (SSRT) function is enabled. See Section 2.9.1 for details.

15. Measured from the 90% point of the rising edge of DOTCLK to 50% of the full-scale transition.

16. Measured from the 50% point of the full-scale transition to the point at which the output has settled, within ± 1 LSB (settling time does not include clock and data feedthrough).

17. Measured between 10% and 90% of the full-scale transition.

3.7 Timing Diagrams

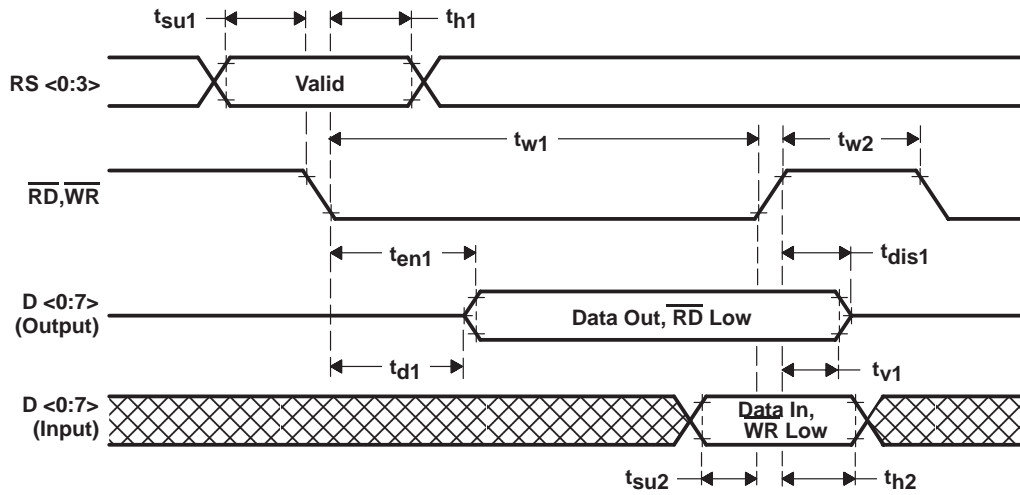

Figure 3–1. MPU Interface Timing

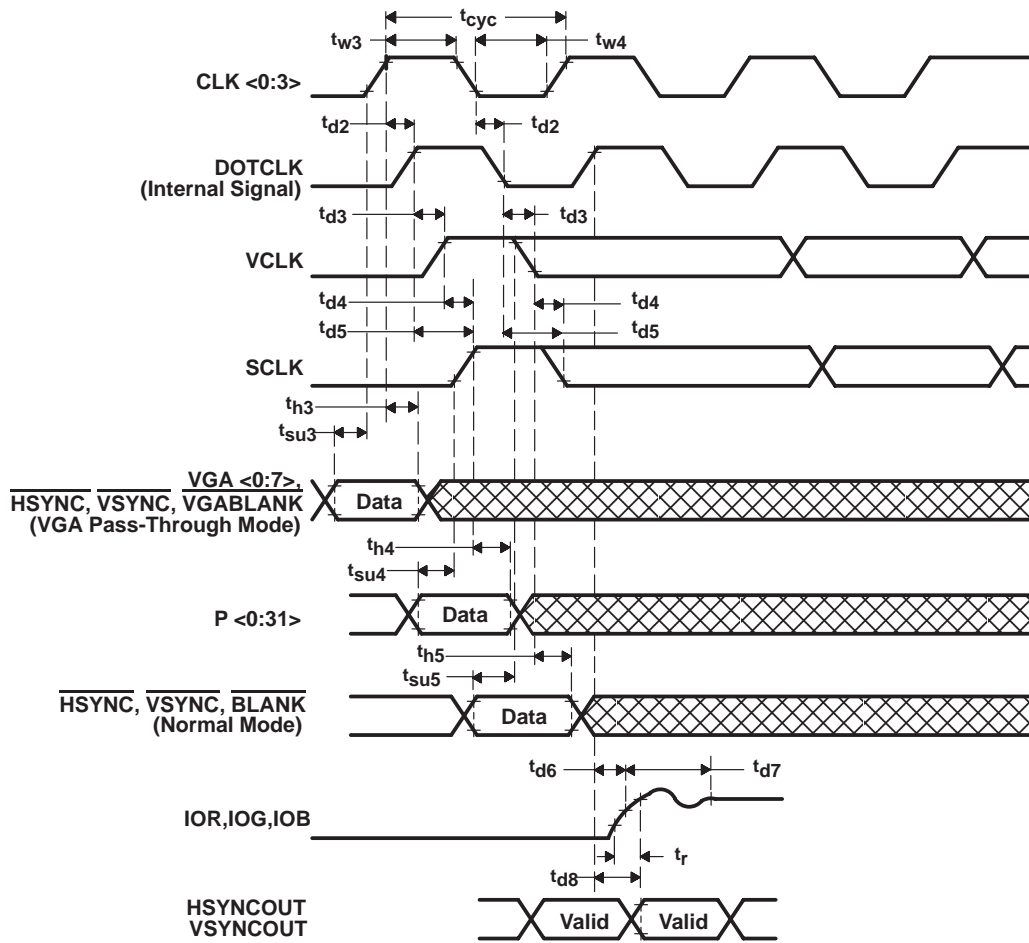

Figure 3-2. Video Input/Output

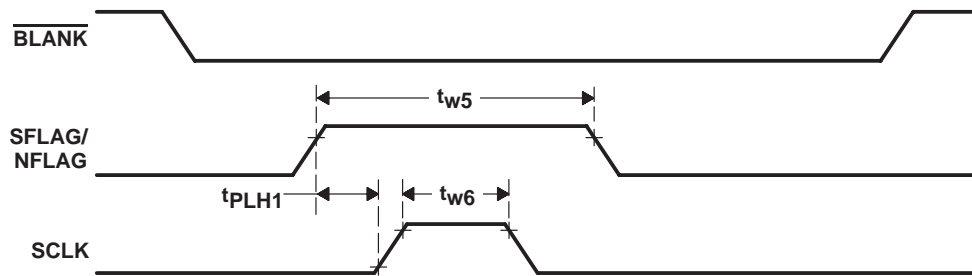

Figure 3-3. SFLAG/NFLAG Timing (When SSRT Function is Enabled)

Appendix A

SCLK/VCLK and the TMS340x0

While the TLC34075A SCLK and VCLK outputs are designed for compatibility with all graphics systems, they are also tightly coupled with the TMS340x0 Graphics System Processors. All the timing requirements of the TMS340x0 have been considered. However, there are a few points that need to be explained with regard to applications.

VCLK

All the video control signals in the TMS340x0 (i.e., $\overline{\text{BLANK}}$, $\overline{\text{HSYNC}}$, and $\overline{\text{VSYNC}}$) are triggered and generated from the falling edge of VCLK. The fact that the TLC34075A uses the falling edge to sample and latch the $\overline{\text{BLANK}}$ input gives users maximum freedom to choose the frequency of VCLK and interconnect the TLC34075A with the TMS340x0 GSP without glue logic. Needless to say, the VCLK frequency needs to be selected to be compatible with the minimum VCLK period required by the TMS340x0.

In the TMS340x0, the same VCLK falling edge that generates $\overline{\text{BLANK}}$ requests a screen refresh. If the VCLK period is longer than 16 TQs (TQ is the period of the TMS340x0 CLKIN), it is possible that the last SCLK pulse could be used falsely to transfer the VRAM data from memory to the shift register along with the last pixel transfer. The first SCLK pulse for the next scan line would then shift the first pixel data out of the pipe and the screen would then falsely start from the second pixel.

SCLK and SFLAG

The TLC34075A SCLK signal is compatible with current -10 and slower VRAMs. When split shift register transfers are used, one SCLK pulse has to be generated between the regular shift register transfer and the split shift register transfer to ensure correct operation. The SFLAG input is designed for this purpose. SFLAG can be generated from a programmable logic array and triggered by the rising edge of the $\overline{\text{TR/QE}}$ signal or the rising edge of the $\overline{\text{RAS}}$ signal of the regular shift register transfer cycle. $\overline{\text{TR/QE}}$ can be used if the minimum delay from when the VRAM's $\overline{\text{TRG}}$ signal goes high to SCLK going high can be met by the programmable logic array delay; otherwise, $\overline{\text{RAS}}$ can be used.

Appendix B

PC Board Layout Considerations

PC Board Considerations

A four-layer PC board should be used with the TLC34075A: one layer each for 5-V power and GND and two layers for signals. The layout should be optimized for the lowest-possible noise on the TLC34075A power and ground lines by shielding the digital inputs and providing good decoupling. The lead length between groups of V_{DD} and GND pins should be minimized so as to reduce inductive ringing. The terminal assignments for the TLC34075A P<0:31> inputs were selected for minimum interconnect lengths between these inputs and the VRAM pixel data outputs. The TLC34075A should be located as close to the output connectors as possible to minimize noise pickup and reflections due to impedance mismatching.

Ground Plane

A single ground plane is recommended for both the TLC34075A and the rest of the logic. Separate digital and analog ground planes are not needed.

Power Plane

Split power planes are recommended for the TLC34075A and the rest of the logic. The TLC34075A and its associated analog circuitry should have their own power plane (referred to as A_{VCC} in Figure B-1). The two power planes should be connected at a single point through a ferrite bead as shown in Figures B-1, B-2, and B-3. This bead should be located within three inches of the TLC34075A.

Supply Decoupling

Bypass capacitors should be installed using the shortest leads possible, consistent with reliable operation, to reduce the lead inductance.

For the best performance, a 0.1- μ F ceramic capacitor in parallel with a 0.01- μ F chip capacitor should be used to decouple each of the three groups of power pins to GND. These capacitors should be placed as close as possible to the device as shown in Figure B-2.

If a switching power supply is used, the designer should pay close attention to reducing power supply noise and should consider using a three-terminal voltage regulator for supplying power to A_{VCC} .

COMP and V_{REF} Terminals

A 100- Ω resistor and 0.1- μ F ceramic capacitor (approximate values) should be connected in series between the device's COMP and V_{DD} terminals in order to avoid noise and color-smearing problems. Also, whether an internal or external voltage reference is used, a 0.1- μ F capacitor should be connected between the device's V_{REF} and GND terminals to further stabilize the video image. These resistor and capacitor values may vary depending on the board layout; experimentation may be required in order to determine optimum values.

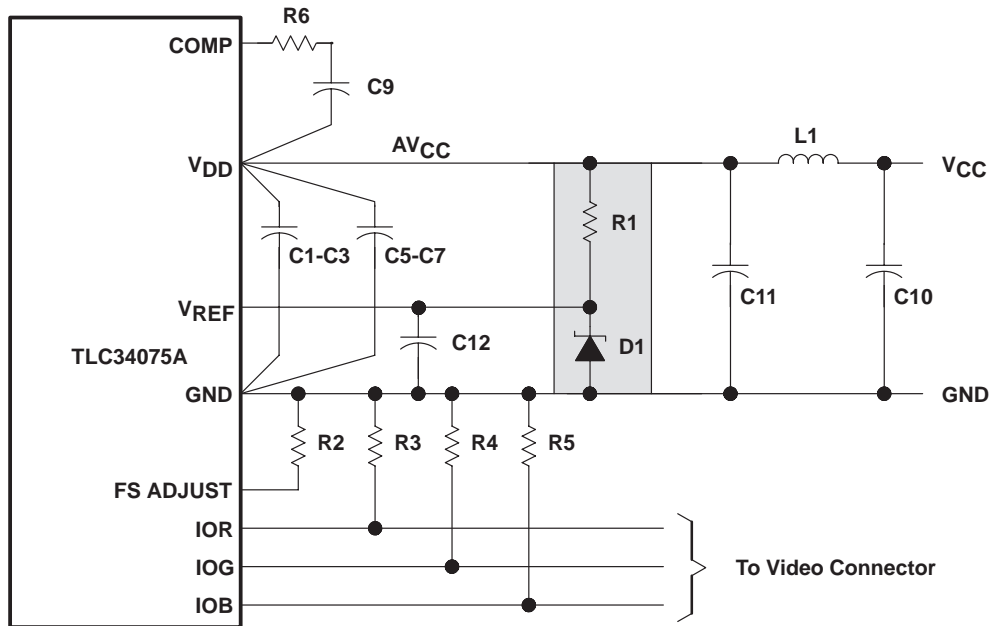

LOCATION	DESCRIPTION
C1-C3, C9-C10, C12	0.1- μ F ceramic capacitor
C5-C7	0.01- μ F ceramic chip capacitor
C11	33- μ F tantalum capacitor
L1	ferrite bead
R1	1000- Ω 1% metal-film resistor
R2	523- Ω 1% metal-film resistor
R3, R4, R5	75- Ω 1% metal-film resistor
R6	100- Ω 5% resistor (optional)
D1	1.2-V voltage reference

Figure B-1. Typical Connection Diagram and Components (Shaded Area is Optional)

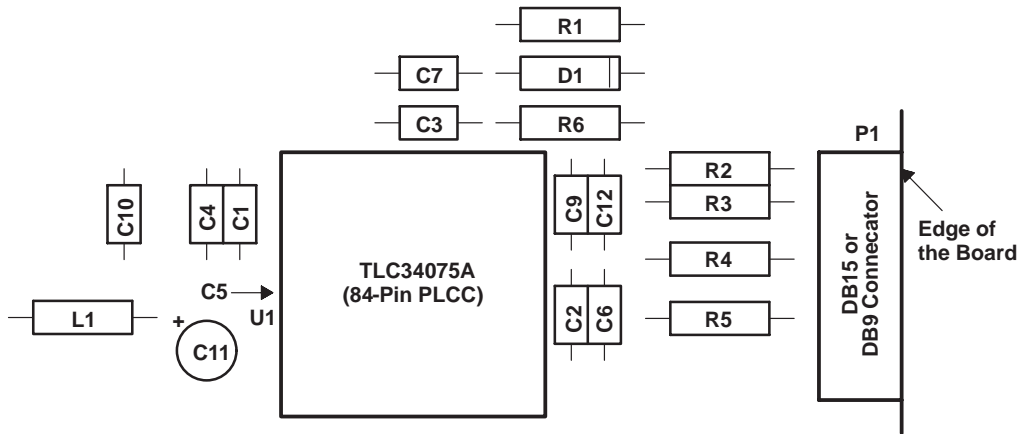

Figure B-2. Typical Component Placement (Component Side)

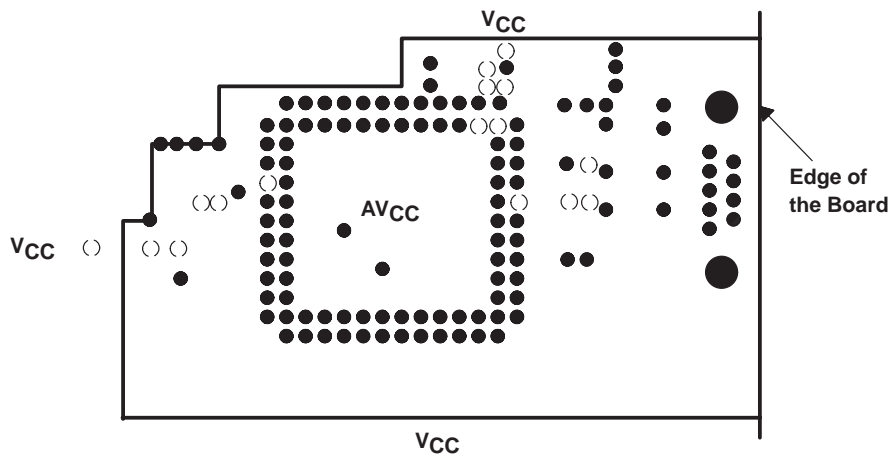

Figure B-3. Typical Split Power Plane (Solder Side)

Appendix C

SCLK Frequency < VCLK Frequency

The VCLK and SCLK outputs generated by the TLC34075A are both free-running clocks. The video control signals (i.e., HSYNC, VSYNC, and BLANK) are normally generated from VCLK, and a fixed relationship between the video control signals and VCLK can therefore be expected. The TLC34075A samples and latches the BLANK input on the falling edge of VCLK. It then looks at the LOAD signal to determine when to disable or enable SCLK at its output terminal. The decision is deterministic when the SCLK frequency is greater than or equal to the VCLK frequency. However, when the SCLK frequency is less than the VCLK frequency, the appearance of the SCLK waveform at its output terminal when BLANK is sampled low on the VCLK falling edge can vary (see Figures C-1 and C-2).

To avoid this variation in the SCLK output waveform, the SCLK and VCLK frequencies should be chosen so that HTOTAL is evenly divisible by the ratio of (VCLK frequency:SCLK frequency); that is,

$$\text{remainder of } \left[\frac{\text{HTOTAL}}{\left(\frac{\text{VCLK frequency}}{\text{SCLK frequency}} \right)} \right] = 0.$$

For example, if HTOTAL is even, VCLK frequency = DOTCLK frequency/8, and SCLK frequency = DOTCLK frequency/16, then the formula above is satisfied. NOTE: When HTOTAL starts at zero (as in the TMS340x0 GSP), then the formula becomes

$$\text{remainder of } \left[\frac{(\text{HTOTAL} + 1)}{\left(\frac{\text{VCLK frequency}}{\text{SCLK frequency}} \right)} \right] = 0.$$

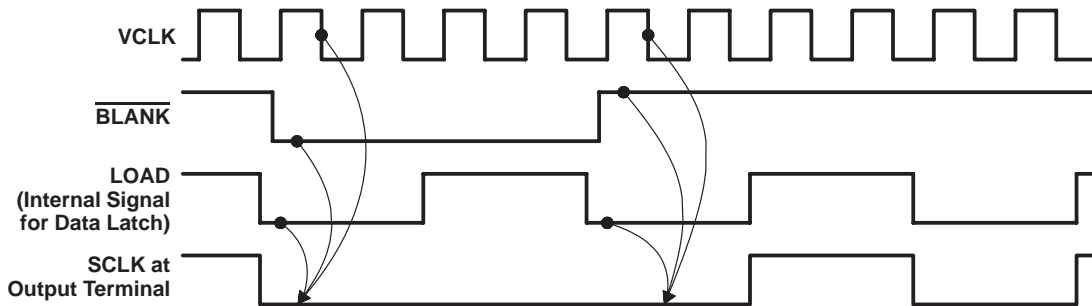

Figure C-1. VCLK and SCLK Phase Relationship (Case 1)

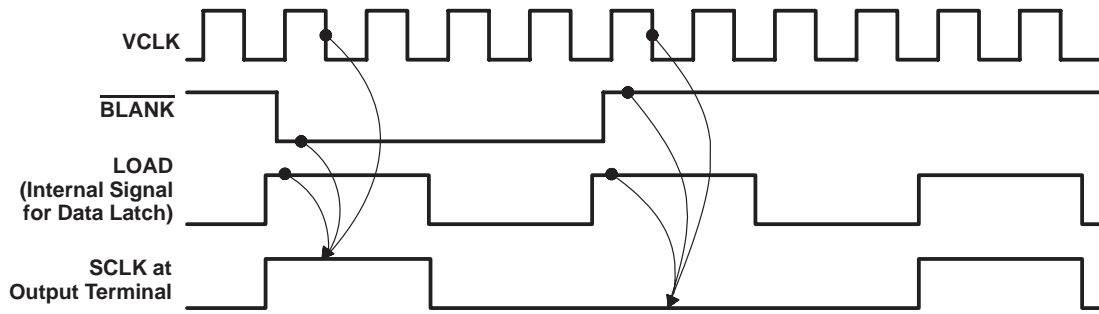
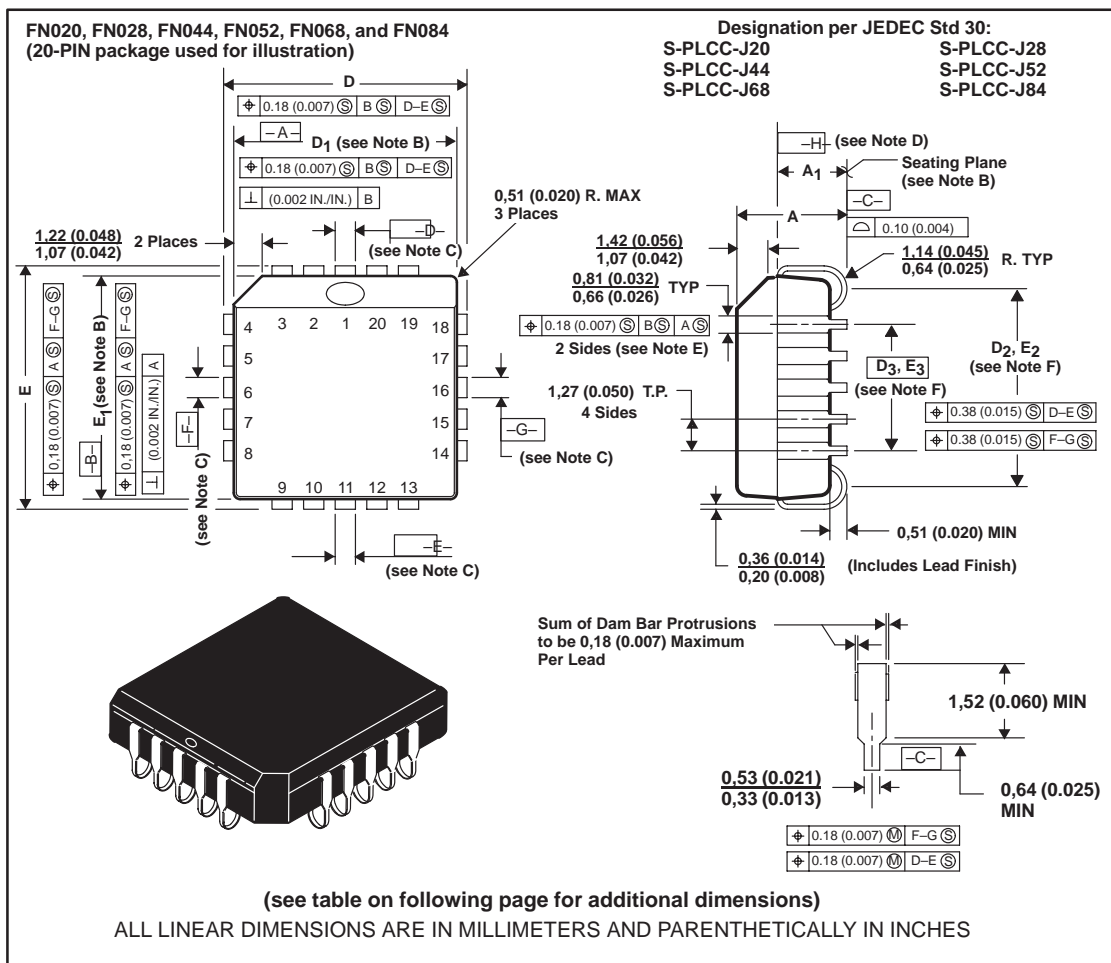

Figure C-2. VCLK and SCLK Phase Relationship (Case 2)

Appendix D Mechanical Data

FN020, FN028, FN044, FN052, FN068, and FN084 plastic J-leaded chip carrier

Each of these chip carrier packages consists of a circuit mounted on a lead frame and encapsulated within an electrically nonconductive plastic compound. The compound withstands soldering temperatures with no deformation, and circuit performance characteristics remain stable when the devices are operated in high-humidity conditions. The package is intended for surface mounting on 1,27 (0.050) centers. Leads require no additional cleaning or processing when used in soldered assembly.



Mechanical Data

JEDEC OUTLINE	NO. OF PINS	A		A ₁		D, E		D ₁ , E ₁		D ₂ , E ₂		D ₃ , E ₃
		MIN	MAX	MIN	MAX	MIN	MAX	MIN	MAX	MIN	MAX	BASIC
MO-047AA	20	4,19 (0.165)	4,57 (0.180)	2,29 (0.090)	3,05 (0.120)	9,78 (0.385)	10,03 (0.395)	8,89 (0.350)	9,04 (0.356)	7,37 (0.290)	8,38 (0.330)	5,08 (0.200)
MO-047AB	28	4,19 (0.165)	4,57 (0.180)	2,29 (0.090)	3,05 (0.120)	12,32 (0.485)	12,57 (0.495)	11,43 (0.450)	11,58 (0.456)	9,91 (0.390)	10,92 (0.430)	7,62 (0.300)
MO-047AC	44	4,19 (0.165)	4,57 (0.180)	2,29 (0.090)	3,05 (0.120)	17,40 (0.685)	17,65 (0.695)	16,51 (0.650)	16,66 (0.656)	14,99 (0.590)	16,00 (0.630)	12,70 (0.500)
MO-047AD	52	4,19 (0.165)	5,08 (0.200)	2,29 (0.090)	3,30 (0.130)	19,94 (0.785)	20,19 (0.795)	19,05 (0.750)	19,20 (0.756)	17,53 (0.690)	18,54 (0.730)	15,24 (0.600)
MO-047AE	68	4,19 (0.165)	5,08 (0.200)	2,29 (0.090)	3,30 (0.130)	25,02 (0.985)	25,27 (0.995)	24,13 (0.950)	24,33 (0.958)	22,61 (0.890)	23,62 (0.930)	20,32 (0.800)
MO-047AF	84	4,19 (0.165)	5,08 (0.200)	2,29 (0.090)	3,30 (0.130)	30,10 (1.185)	30,35 (1.195)	29,21 (1.150)	29,41 (1.141)	27,69 (1.090)	28,70 (1.130)	25,40 (1.000)

NOTES: A. All dimensions conform to JEDEC Specification MO-047AA/AF. Dimensions and tolerancing are per ANSI Y14.5M – 1982.

- B. Dimensions D₁ and E₁ do not include mold flash protrusion. Protrusion shall not exceed 0,25 (0.010) on any side. Centerline of center pin each side is within 0,10 (0.004) of package centerline by dimension B. The lead contact points are planar within 0,10 (0.004).
- C. Datums D – E and F – G for center leads are determined at datum – H –.
- D. Datum – H – is located at top of leads where they exit plastic body.
- E. Location of datums – A – and – B – to be determined at datum – H –.
- F. Determined at seating plane – C –.

IMPORTANT NOTICE

Texas Instruments and its subsidiaries (TI) reserve the right to make changes to their products or to discontinue any product or service without notice, and advise customers to obtain the latest version of relevant information to verify, before placing orders, that information being relied on is current and complete. All products are sold subject to the terms and conditions of sale supplied at the time of order acknowledgement, including those pertaining to warranty, patent infringement, and limitation of liability.

TI warrants performance of its semiconductor products to the specifications applicable at the time of sale in accordance with TI's standard warranty. Testing and other quality control techniques are utilized to the extent TI deems necessary to support this warranty. Specific testing of all parameters of each device is not necessarily performed, except those mandated by government requirements.

CERTAIN APPLICATIONS USING SEMICONDUCTOR PRODUCTS MAY INVOLVE POTENTIAL RISKS OF DEATH, PERSONAL INJURY, OR SEVERE PROPERTY OR ENVIRONMENTAL DAMAGE ("CRITICAL APPLICATIONS"). TI SEMICONDUCTOR PRODUCTS ARE NOT DESIGNED, AUTHORIZED, OR WARRANTED TO BE SUITABLE FOR USE IN LIFE-SUPPORT DEVICES OR SYSTEMS OR OTHER CRITICAL APPLICATIONS. INCLUSION OF TI PRODUCTS IN SUCH APPLICATIONS IS UNDERSTOOD TO BE FULLY AT THE CUSTOMER'S RISK.

In order to minimize risks associated with the customer's applications, adequate design and operating safeguards must be provided by the customer to minimize inherent or procedural hazards.

TI assumes no liability for applications assistance or customer product design. TI does not warrant or represent that any license, either express or implied, is granted under any patent right, copyright, mask work right, or other intellectual property right of TI covering or relating to any combination, machine, or process in which such semiconductor products or services might be or are used. TI's publication of information regarding any third party's products or services does not constitute TI's approval, warranty or endorsement thereof.