

SN75ALS1711 TRIPLE DIFFERENTIAL BUS TRANSCEIVER

SLLS117B – APRIL 1991 – REVISED MAY 1995

- Three Bidirectional Transceivers
- Driver/Receiver Meets or Exceeds the Requirements of ANSI Standard RS-485 and ANSI Standard X3.131-1986 (SCSI)
- High-Speed Advanced Low-Power Schottky Circuitry
- Designed for Multipoint Transmission on Long Bus Lines in Noisy Environments
- Wide Positive and Negative Input/Output Bus Voltages Ranges . . . -7 V to 12 V
- Driver Output Capacity . . . $\pm 60\text{ mA}$
- Driver Positive and Negative Current Limiting
- Thermal Shutdown Protection
- Receiver Input Sensitivity . . . $\pm 200\text{ mV Max}$
- Receiver Input Impedance . . . $12\text{ k}\Omega\text{ Min}$
- Receiver Input Hysteresis . . . 50 mV Typ
- Operates From a Single 5-V Supply
- Low Supply-Current Requirements
72 mA Max
- Glitch-Free Power-up and Power-Down Protection

description

The SN75ALS1711 triple differential bus transceiver is a monolithic integrated circuit designed for bidirectional data communication on multipoint bus transmission lines. It is designed for balanced transmission lines and meets ANSI Standard RS-485 and ANSI Standard X3.131-1986 (SCSI).

The SN75ALS1711 operates from a single 5-V power supply. The drivers and receivers have individual active-high and active-low enables, respectively, which can be externally connected together to function as a direction control. The driver differential output and the receiver differential input pairs are connected internally to form differential input/output (I/O) bus ports that are designed to offer minimum loading to the bus when the driver is disabled or V_{CC} is at 0. These ports feature wide positive and negative common-mode voltage ranges making the device suitable for party-line applications.

The SN75ALS1711 is characterized for operation from 0°C to 70°C .

DW OR N PACKAGE
(TOP VIEW)

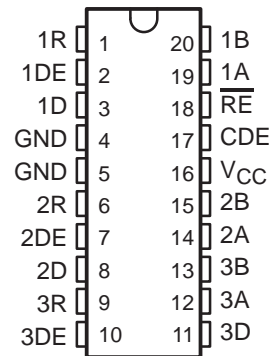

Function Tables

EACH DRIVER

INPUT D	ENABLES		OUTPUTS	
	DE	CDE	A	B
H	H	H	H	L
L	H	H	L	H
X	L	X	Z	Z
X	X	L	Z	Z

EACH RECEIVER

DIFFERENTIAL INPUTS A – B	ENABLE $\overline{\text{RE}}$	OUTPUT R
$V_{ID} \geq 0.2\text{ V}$	L	H
$V_{ID} = -0.2\text{ V to } 0.2\text{ V}$	L	?
$V_{ID} \leq -0.2\text{ V}$	L	L
X	H	Z
Open	L	H

H = high level, L = low-level, ? = indeterminate,
X = irrelevant, Z = high impedance (off)

SN75ALS1711 TRIPLE DIFFERENTIAL BUS TRANSCEIVER

SLLS117B – APRIL 1991 – REVISED MAY 1995

logic symbol†

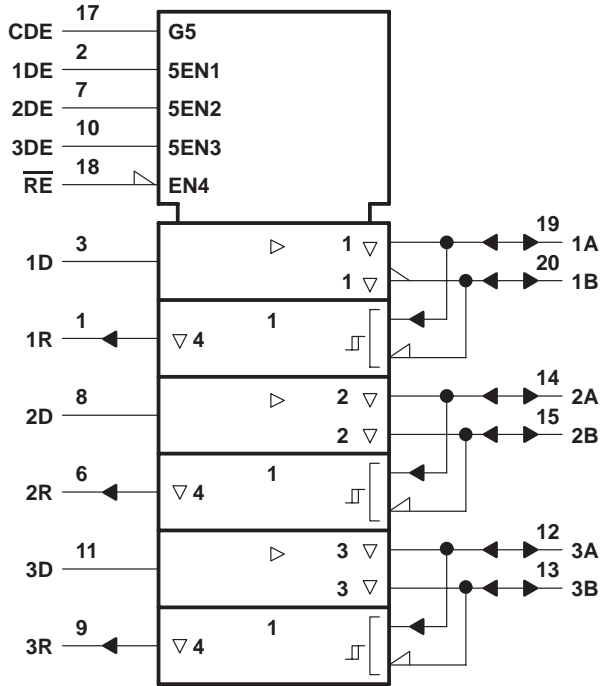

logic diagram (positive logic)

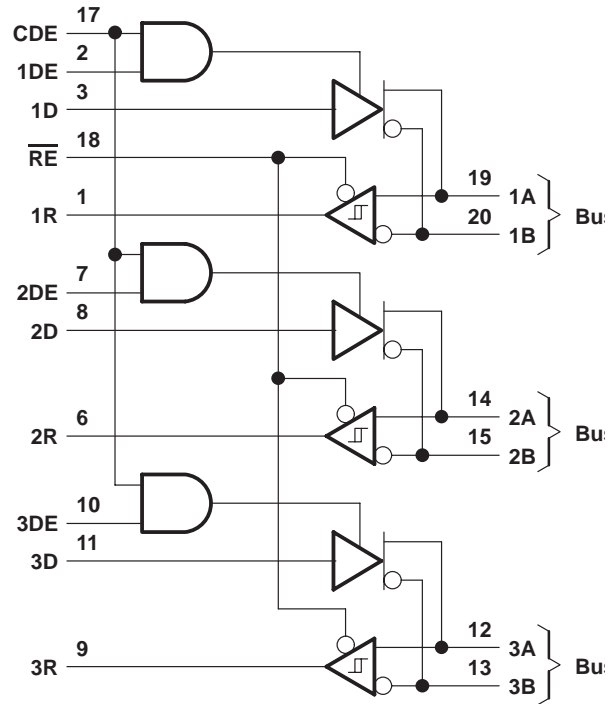

† This symbol is in accordance with ANSI/IEEE Std 91-1984 and IEC Publication 617-12.

schematics of inputs and outputs

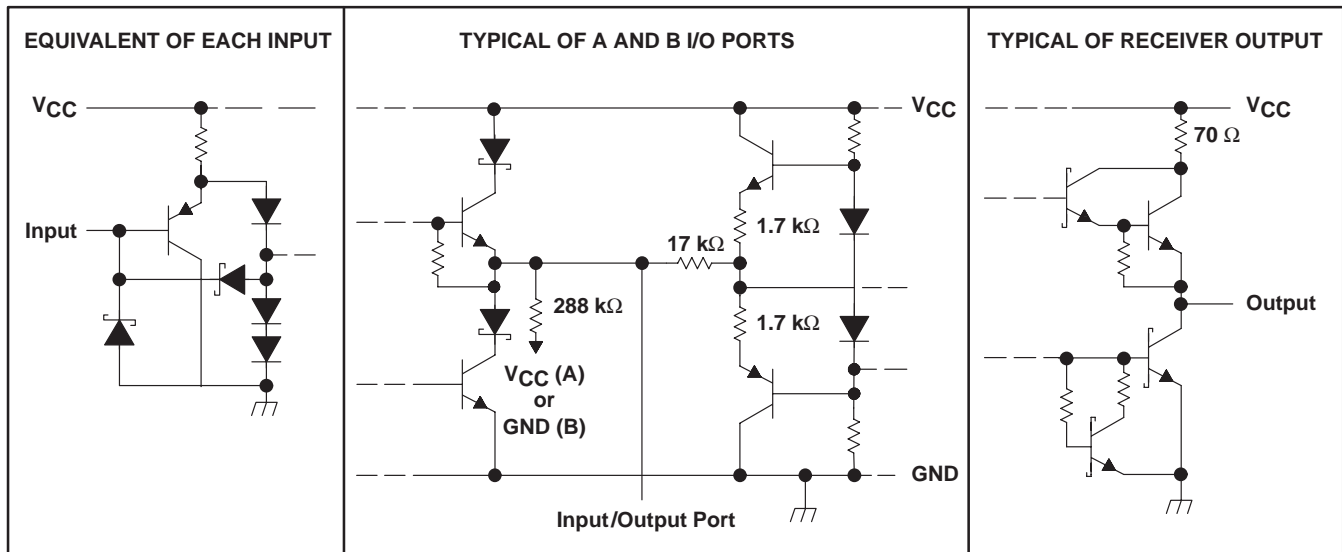

All values are nominal.

absolute maximum ratings over operating free-air temperature range (unless otherwise noted)†

Supply voltage range, V_{CC} (see Note 1)	–0.5 V to 7 V
Enable input voltage range, V_I	–0.5 V to $V_{CC} + 0.5$ V
Input voltage range, V_I : Driver	–0.5 V to $V_{CC} + 0.5$ V
Receiver	–9 V to 14 V
Output voltage range, V_O : Driver	–9 V to 14 V
Receiver	–0.5 V to $V_{CC} + 0.5$ V
Continuous total power dissipation	See Dissipation Rating Table
Operating free-air temperature range, T_A	0°C to 70°C
Storage temperature range, T_{stg}	–65°C to 150°C
Lead temperature 1,6 mm (1/16 inch) from case for 10 seconds	260°C

† Stresses beyond those listed under “absolute maximum ratings” may cause permanent damage to the device. These are stress ratings only, and functional operation of the device at these or any other conditions beyond those indicated under “recommended operating conditions” is not implied. Exposure to absolute-maximum-rated conditions for extended periods may affect device reliability.

NOTE 1: All voltage values, except differential input/output bus voltage, are with respect to network ground terminal.

DISSIPATION RATING TABLE

PACKAGE	$T_A \leq 25^\circ\text{C}$ POWER RATING	DERATING FACTOR ABOVE $T_A = 25^\circ\text{C}$	$T_A = 70^\circ\text{C}$ POWER RATING
DW	1125 mW	9.0 mW/°C	720 mW
N	1150 mW	9.2 mW/°C	736 mW

recommended operating conditions

		MIN	TYP	MAX	UNIT
Supply voltage, V_{CC}		4.75	5	5.25	V
Common-mode input voltage at any bus terminal, V_{IC} (see Note 2)		–7‡		12	V
High-level input voltage, V_{IH}	D, DE, \overline{RE} , CDE	2			V
Low-level input voltage, V_{IL}	D, DE, \overline{RE} , CDE			0.8	V
High-level output current, I_{OH}	Driver			–60	mA
	Receiver			–400	μA
Low-level output current, I_{OL}	Driver			60	mA
	Receiver			8	
Operating free-air temperature, T_A		0		70	°C

‡ The algebraic convention, in which the less-positive (more-negative) limit is designated minimum, is used in this data sheet for common-mode input voltage and threshold voltage levels only.

NOTE 2: Differential-input/output bus voltage is measured at the noninverting terminal A with respect to the inverting terminal B.

SN75ALS1711

TRIPLE DIFFERENTIAL BUS TRANSCEIVER

SLLS117B – APRIL 1991 – REVISED MAY 1995

DRIVER SECTION

electrical characteristics over recommended ranges of supply voltage and operating free-air temperature (unless otherwise noted)

PARAMETER		TEST CONDITIONS	MIN	TYP†	MAX	UNIT	
V _{IK}	Input clamp voltage	I _I = -18 mA			-1.5	V	
V _O	Output voltage	I _O = 0	0		6	V	
V _{OD1}	Differential output voltage	I _O = 0	1.5		5	V	
V _{OD2}	Differential output voltage	R _L = 54 Ω, See Figure 1	1.5		5	V	
V _{OD3}	Differential output voltage	See Note 3 and Figure 2	1.5		5	V	
Δ V _{OD}	Change in magnitude of differential output voltage‡	R _L = 54 Ω, See Figure 1			±0.2	V	
V _{OC}	Common-mode output voltage	R _L = 54 Ω, See Figure 1			3 -1	V	
Δ V _{OC}	Change in magnitude of common-mode output voltage‡	R _L = 54 Ω, See Figure 1			±0.2	V	
I _{OZ}	High-impedance state output current	Output disabled, V _{CC} = 5.25 V	V _O = 12 V		1	mA	
			V _O = 7 V		-0.8		
I _{IH}	High-level input current, DE, EN, CDE	V _{IH} = 2.4 V			20	μA	
I _{IL}	Low-level input current, DE, EN, CDE	V _{IL} = 0.4 V			-200	μA	
I _{OS}	Short-circuit output current	V _O = 12 V			-250	mA	
		V _O = 7 V			250		
I _{CC}	Supply current	No load	Outputs enabled		48	72	mA
			Outputs disabled		30	48	

† All typical values are at V_{CC} = 5 V and T_A = 25°C.

‡ Δ|V_{OD}| and Δ|V_{OC}| are the changes in magnitude of V_{OD} and V_{OC}, respectively, that occur when the input is changed from a high level to a low level.

NOTE 3: This applies for both power on and off; refer to ANSI Standard RS-485 for exact conditions.

switching characteristics, V_{CC} = 5 V ± 5%, T_A = 25°C

PARAMETER		TEST CONDITIONS	MIN	TYP	MAX	UNIT	
t _{PLH}	Differential propagation delay time, low- to high-level output	R _L = 54 Ω, C _L = 100 pF, See Figure 3	8	13	22	ns	
t _{PHL}	Differential propagation delay time, high- to low-level output		8	15	22		
t _{PZH}	Output enable time to high level	R _L = 110 Ω, See Figure 4	S1 open, S2 closed		30	50	ns
t _{PHZ}	Output disable time from high level		S1 closed, S2 open		4	16	
t _{PZL}	Output enable time to low level		S1 closed, S2 open		16	26	
t _{PLZ}	Output disable time from low level		S1 closed, S2 open		4	8	



RECEIVER SECTION

electrical characteristics over recommended ranges of common-mode input voltage, supply voltage, and operating free-air temperature (unless otherwise noted)

PARAMETER		TEST CONDITIONS	MIN	TYP†	MAX	UNIT
V_{IT+}	Positive-going input threshold voltage	$V_O = 2.7\text{ V}$, $I_O = -0.4\text{ mA}$			0.2	V
V_{IT-}	Negative-going input threshold voltage	$V_O = 0.5\text{ V}$, $I_O = 4\text{ mA}$	$-0.2\ddagger$			V
V_{hys}	Hysteresis voltage ($V_{IT+} - V_{IT-}$)			50		mV
V_{IK}	Input clamp voltage, \overline{RE}	$I_I = 18\text{ mA}$			-1.5	V
V_{OH}	High-level output voltage	$I_{OH} = -0.4\text{ mA}$	2.4			V
V_{OL}	Low-level output voltage	$I_{OL} = 4\text{ mA}$			0.5	V
I_{OZ}	High-impedance-state output current	$V_{CC} = 5.25\text{ V}$, $V_O = 0.4\text{ V to } 2.4\text{ V}$			± 20	μA
I_I	Line input current	Other input at 0, See Note 3			1	mA
			$V_I = 12\text{ V}$		-0.8	
I_{IH}	High-level input current, \overline{RE}	$V_{IH} = 2.4\text{ V}$			20	μA
I_{IL}	Low-level input current, \overline{RE}	$V_{IL} = 0.4\text{ V}$			-200	μA
r_i	Input resistance		12			k Ω
I_{OS}	Short-circuit output current \S	$V_O = 0$	-15		-130	mA
I_{CC}	Supply current	No load	Outputs enabled	48	72	mA
			Outputs disabled	30	48	

† All typical values are at $V_{CC} = 5\text{ V}$ and $T_A = 25^\circ\text{C}$.

‡ The algebraic convention, in which the less-positive (more-negative) limit is designated minimum, is used in this data sheet for common-mode input voltage and threshold voltage levels only.

§ Not more than one output should be shorted at one time.

NOTE 3: This applies for both power on and off; refer to ANSI Standard RS-485 for exact conditions.

switching characteristics, $V_{CC} = 5\text{ V} \pm 5\%$, $T_A = 25^\circ\text{C}$

PARAMETER		TEST CONDITIONS	MIN	TYP	MAX	UNIT
t_{PLH}	Propagation delay time, low- to high-level output	See Figures 5 and 6	13	20	37	ns
t_{PHL}	Propagation delay time, high- to low-level output		13	20	37	
t_{PZH}	Output enable time to high level	See Figures 5 and 7	3	9	20	ns
t_{PHZ}	Output disable time from high level					
t_{PZL}	Output enable time to low level		5	10	20	
t_{PZL}	Output enable time to low level					

SN75ALS1711 TRIPLE DIFFERENTIAL BUS TRANSCEIVER

SLLS117B – APRIL 1991 – REVISED MAY 1995

PARAMETER MEASUREMENT INFORMATION

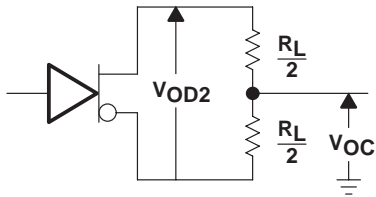

Figure 1. Driver V_{OD2} and V_{OC}

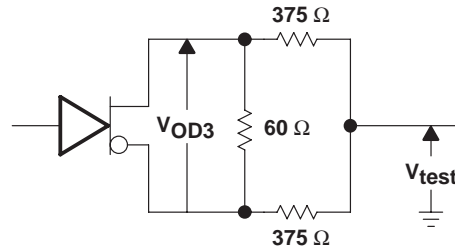

Figure 2. Driver V_{OD3}

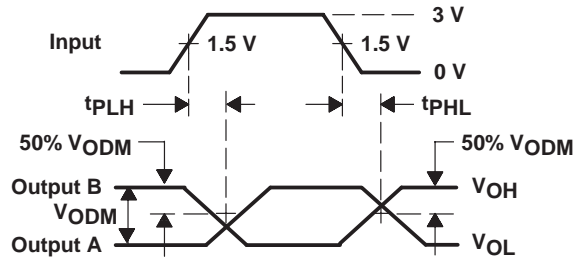
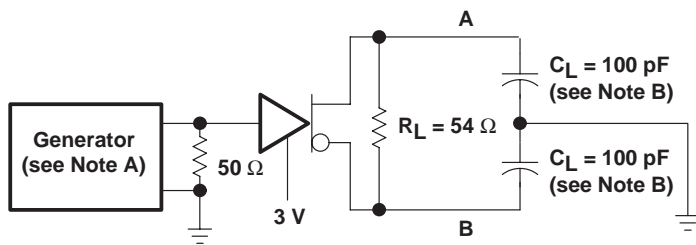
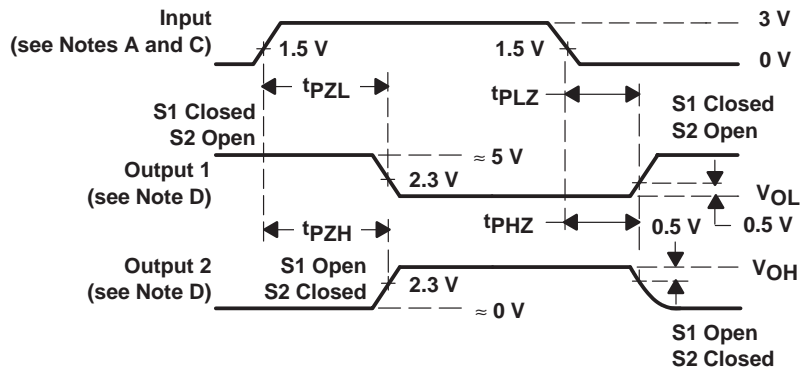
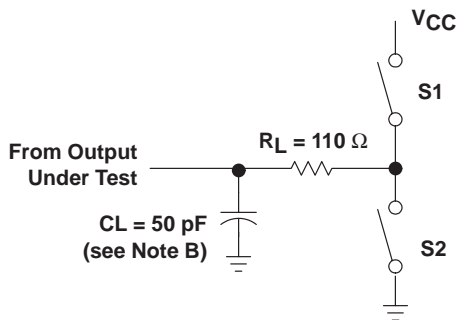

Figure 3. Driver Propagation Delay Times



- NOTES: A. All input pulses are supplied by generators having the following characteristics: $PRR \leq 1 \text{ MHz}$, $Z_O = 50 \Omega$, $t_r \leq 10 \text{ ns}$, $t_f \leq 10 \text{ ns}$.
 B. C_L includes probe and jig capacitance.
 C. Each enable is tested separately.
 D. Output 1 and output 2 are outputs with internal conditions such that the output is low or high except when disabled by the output control.

Figure 4. Driver Enable/Disable Times

IMPORTANT NOTICE

Texas Instruments (TI) reserves the right to make changes to its products or to discontinue any semiconductor product or service without notice, and advises its customers to obtain the latest version of relevant information to verify, before placing orders, that the information being relied on is current and complete.

TI warrants performance of its semiconductor products and related software to the specifications applicable at the time of sale in accordance with TI's standard warranty. Testing and other quality control techniques are utilized to the extent TI deems necessary to support this warranty. Specific testing of all parameters of each device is not necessarily performed, except those mandated by government requirements.

Certain applications using semiconductor products may involve potential risks of death, personal injury, or severe property or environmental damage ("Critical Applications").

TI SEMICONDUCTOR PRODUCTS ARE NOT DESIGNED, INTENDED, AUTHORIZED, OR WARRANTED TO BE SUITABLE FOR USE IN LIFE-SUPPORT APPLICATIONS, DEVICES OR SYSTEMS OR OTHER CRITICAL APPLICATIONS.

Inclusion of TI products in such applications is understood to be fully at the risk of the customer. Use of TI products in such applications requires the written approval of an appropriate TI officer. Questions concerning potential risk applications should be directed to TI through a local SC sales office.

In order to minimize risks associated with the customer's applications, adequate design and operating safeguards should be provided by the customer to minimize inherent or procedural hazards.

TI assumes no liability for applications assistance, customer product design, software performance, or infringement of patents or services described herein. Nor does TI warrant or represent that any license, either express or implied, is granted under any patent right, copyright, mask work right, or other intellectual property right of TI covering or relating to any combination, machine, or process in which such semiconductor products or services might be or are used.