

MMC, SD CARD, Memory Stick™, SmartMedia, AND xD-Picture Card™ ±15-kV ESD-PROTECTED VOLTAGE-TRANSLATION TRANSCEIVER

SCES615B – OCTOBER 2004 – REVISED DECEMBER 2004

- Transceiver for Memory Card Interface [MultiMediaCard (MMC), Secure Digital (SD), Memory Stick™ Compliant Products, SmartMedia Card, and xD-Picture Card™]
- Configurable I/O Switching Levels With Dual-Supply Pins Operating Over Full 1.4-V to 3.6-V Power-Supply Range
- For Low Power Operation, A Ports Are Placed in High-Impedance State When Card-Side Supply Voltage Is Switched Off
- Latch-Up Performance Exceeds 100 mA Per JESD 78, Class II
- ESD Protection for Card-Side Pins (B Port)
 - ±15 kV (±12 kV on Pin 14B) - IEC 61000-4-2 ESD, Air Gap Discharge
 - ±8 kV - IEC 61000-4-2 ESD, Contact Discharge
- ESD Protection for A-Port Pins (Tested Per JESD 22) Exceeds:
 - 2000-V Human-Body Model (A114-B)
 - 1000-V Charged-Device Model (C101)

description/ordering information

The SN74AVCA406 is a transceiver for interfacing microprocessors with MultiMediaCards (MMCs), secure digital (SD) cards, Memory Stick™ compliant products, SmartMedia cards, or xD-Picture Cards™. It integrates high ESD protection, which eliminates the need for external ESD diodes. Two supply-voltage pins allow the A-port and B-port input switching thresholds to be configured separately. The A port is designed to track V_{CCA} , while the B port is designed to track V_{CCB0} and V_{CCB1} . V_{CCA} , V_{CCB0} and V_{CCB1} can accept any supply voltage from 1.4 V to 3.6 V.

Memory card standards recommend high ESD protection for devices that connect directly to the external memory card. To meet this need, the SN74AVCA406 incorporates ±15-kV air gap discharge and ±8-kV contact discharge protection on the card side. If V_{CCB0} and V_{CCB1} are switched off (no card inserted), the A-port outputs are placed in the high-impedance state to conserve power.

The SN74AVCA406 enables system designers to easily interface low-voltage microprocessors to different memory cards operating at higher voltages. The mode (MODE0 and MODE1) pins are used to configure the device to interface with different types of cards.

The SN74AVCA406 is offered in the 48-ball MicroStar Jr.™ ball grid array (BGA) package. This package has dimensions of 4 × 4 mm, with a 0.5-mm ball pitch for effective board-space savings. Memory cards are widely used in mobile phones, PDAs, digital cameras, personal media players, camcorders, set-top boxes, etc. Low static power consumption and small package size make the SN74AVCA406 an ideal choice for these applications.

ORDERING INFORMATION

T _A	PACKAGE†		ORDERABLE PART NUMBER	TOP-SIDE MARKING
-40°C to 85°C	VFBGA - GQC	Tape and reel	SN74AVCA406GQCR	WM406

† Package drawings, standard packing quantities, thermal data, symbolization, and PCB design guidelines are available at www.ti.com/sc/package.



Please be aware that an important notice concerning availability, standard warranty, and use in critical applications of Texas Instruments semiconductor products and disclaimers thereto appears at the end of this data sheet.

All trademarks are the property of their respective owners.

PRODUCTION DATA information is current as of publication date. Products conform to specifications per the terms of Texas Instruments standard warranty. Production processing does not necessarily include testing of all parameters.



POST OFFICE BOX 655303 • DALLAS, TEXAS 75265

Copyright © 2004, Texas Instruments Incorporated

SN74AVCA406

MMC, SD CARD, Memory Stick™, SmartMedia, AND xD-Picture Card™

±15-kV ESD-PROTECTED VOLTAGE-TRANSLATION TRANSCEIVER

SCES615B – OCTOBER 2004 – REVISED DECEMBER 2004

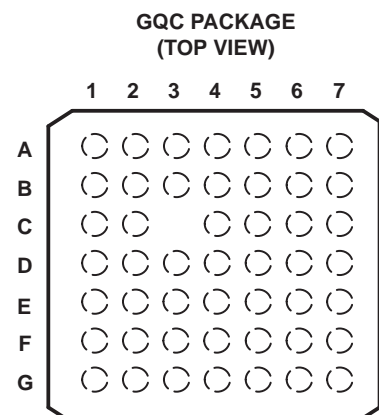

terminal assignments

	1	2	3	4	5	6	7
A	V _{CCA}	2A	4DIR	2DIR	MODE1	10B1	V _{CCB0}
B	10A1	3A	1A	1DIR	MODE0	9B1	1B
C	9A	10A2		3DIR	GND	2B	3B
D	9DIR	4A	56DIR	GND	4B	11B	12B
E	78DIR	6A	GND	$\overline{CS0}$	GND	10B2	9B2
F	7A	8A	12A	13A	7B	5B	14B
G	V _{CCA}	5A	11A	$\overline{CS1}$	8B	6B	V _{CCB1}

V_{CCA} powers all A-port I/Os and control inputs.

V_{CCB0} powers 1B, 2B, 3B, 4B, 9B1, and 10B1.

V_{CCB1} powers 5B, 6B, 7B, 8B, 9B2, 10B2, 11B, 12B, and 14B.

device operation

The A port is designed to track V_{CCA}. V_{CCA} accepts any supply voltage from 1.4 V to 3.6 V. The B port is designed to track V_{CCB0} and V_{CCB1}. V_{CCB0} and V_{CCB1} can accept any supply voltage from 1.4 V to 3.6 V, however, V_{CCB0}, V_{CCB1}, or both must be greater than or equal to V_{CCA} during normal operation. If V_{CCB0} and V_{CCB1} are both at GND, the A port is in the high-impedance state. The control pins are supplied by V_{CCA}. The microprocessor is connected to the A port, and the memory card(s) are connected to the B port. The device can be configured using MODE0, MODE1, $\overline{CS0}$, and $\overline{CS1}$ pins to interface with 1-bit, 4-bit, or 8-bit memory cards. Outputs 12A and 14B are push-pull and open drain (OD), respectively, except for NAND flash (XD) mode, where they are open drain and push-pull, respectively.

Table 1. Interface With Different Memory Cards

MODE0	MODE1	MEMORY CARD INTERFACE
0	X	SD/SDIO/MMC/Memory Stick/Memory Stick PRO
1	0	8-bit MMC/4-bit + GPIO translation
1	1	SmartMedia/xD-Picture Card

SN74AVCA406
MMC, SD CARD, Memory Stick™, SmartMedia, AND xD-Picture Card™
±15-kV ESD-PROTECTED VOLTAGE-TRANSLATION TRANSCEIVER

SCES615B – OCTOBER 2004 – REVISED DECEMBER 2004

**configuration 1a – interfacing with SD or SDIO card
 (SD mode or SD 4-bit mode)**

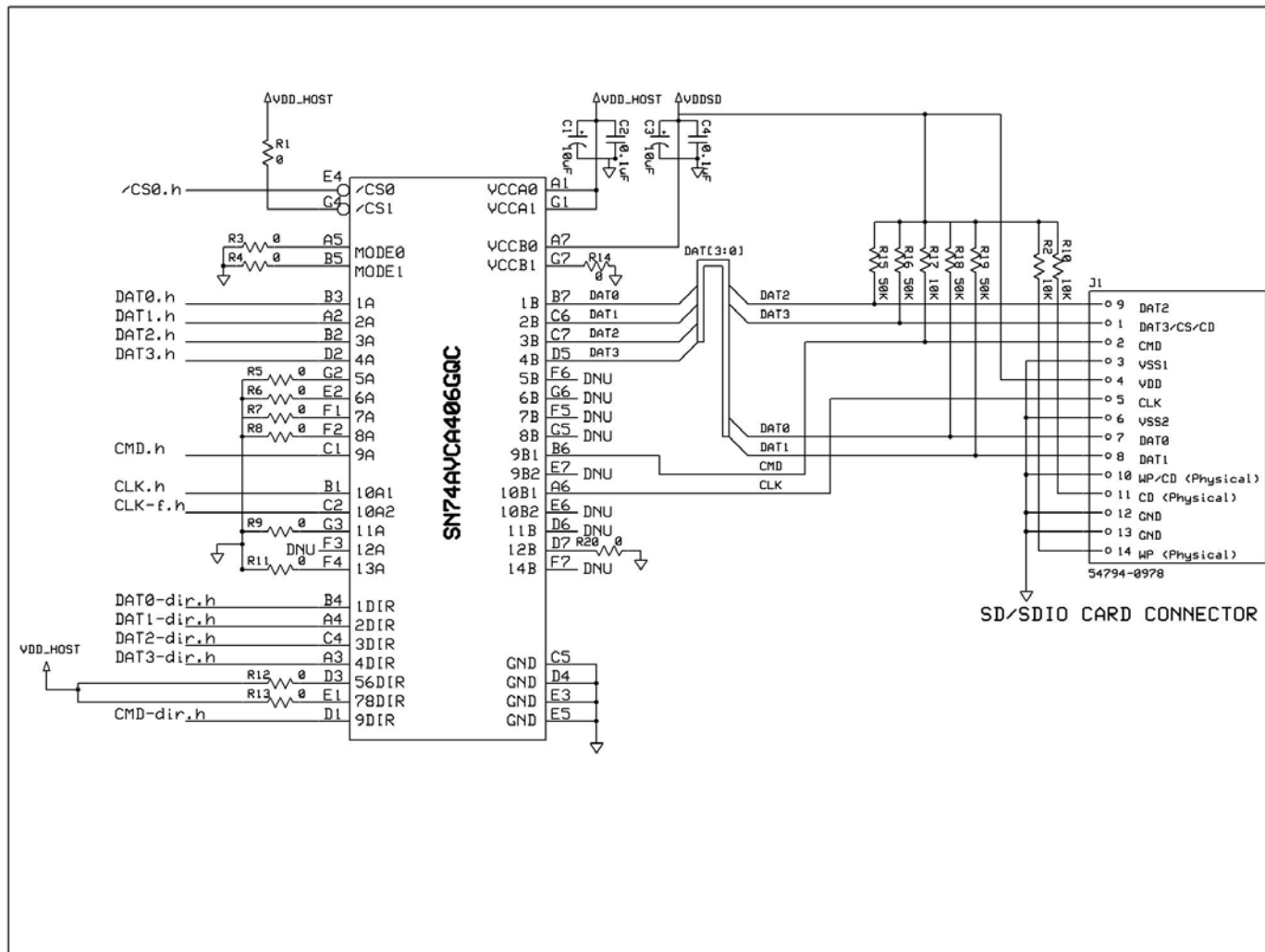

SN74AVCA406
MMC, SD CARD, Memory Stick™, SmartMedia, AND xD-Picture Card™
±15-kV ESD-PROTECTED VOLTAGE-TRANSLATION TRANSCEIVER

SCES615B – OCTOBER 2004 – REVISED DECEMBER 2004

Table 2. SD or SDIO Card

PIN NO.	PIN NAME	SIGNAL NAME OR (CONNECTION)	PIN FUNCTION	PIN TYPE
A1	V _{CCA}	V _{CCA}	A-port supply voltage. V _{CCA} powers all A-port I/Os and control inputs.	Power
B1	10A1	CLK.h	Clock signal from host	Input
C1	9A	CMD.h	Command signal connected to host	I/O
D1	9DIR	CMD-dir.h	Direction control for 9A/9B connected to host	Input
E1	78DIR	(tie-high)	Direction control for 7A/7B and 8A/8B. Not used in this mode. Tie to V _{CCA} .	Input
F1	7A	(tie-low)	I/O pin not used in this mode. Tie to GND.	I/O
G1	V _{CCA}	V _{CCA}	A-port supply voltage. V _{CCA} powers all A-port I/Os and control inputs.	Power
A2	2A	DAT1.h	Data bit 2 connected to host. Referenced to V _{CCA} .	I/O
B2	3A	DAT2.h	Data bit 3 connected to host. Referenced to V _{CCA} .	I/O
C2	10A2	CLK-f.h	Clock feedback to host for resynchronizing data. Used in OMAP processors. Optional on other processors. Leave unconnected if not used.	Output
D2	4A	DAT3.h	Data bit 4 connected to host. Referenced to V _{CCA} .	I/O
E2	6A	(tie-low)	I/O pin not used in this mode. Tie to GND.	I/O
F2	8A	(tie-low)	I/O pin not used in this mode. Tie to GND.	I/O
G2	5A	(tie-low)	I/O pin not used in this mode. Tie to GND.	I/O
A3	4DIR	DAT3-dir.h	Direction control for 4A/4B	Input
B3	1A	DAT0.h	Data bit 1 connected to host. Referenced to V _{CCA} .	I/O
C3			Depopulated ball	
D3	56DIR	(tie-high)	Direction control for 5A/5B and 6A/6B. Not used in this mode. Tie to V _{CCA} .	Input
E3	GND	GND	Ground	
F3	12A	DNU	Output pin not used in this mode. Do not use. Leave unconnected.	Output
G3	11A	(tie-low)	Input pin not used in this mode. Tie to GND.	Input
A4	2DIR	DAT1-dir.h	Direction control for 2A/2B connected to host	Input
B4	1DIR	DAT0-dir.h	Direction control for 1A/1B connected to host	Input
C4	3DIR	DAT2-dir.h	Direction control for 3A/3B connected to host	Input
D4	GND	GND	Ground	
E4	$\overline{\text{CS0}}$	$\overline{\text{CS0}}$.h	Card select from host. Active low. When CS0/ = high, 1A, 2A, 3A, 4A, 1B, 2B, 3B, 4B, 9A, 9B1, and 10A2 are placed in Hi Z and 10B1 is low.	Input
F4	13A	(tie-low)	Input pin not used in this mode. Tie to GND.	Input
G4	$\overline{\text{CS1}}$	(tie-high)	Card select. Not used in this mode. Tie to V _{CCA} for proper operation.	Input
A5	MODE1	(tie-low)	MODE1, MODE0 determine mode of operation (see Table 1). Tie to GND in this mode.	Input
B5	MODE0	(tie-low)		Input
C5	GND	GND	Ground	
D5	4B	DAT3	Data bit 4 connected to card. Referenced to V _{CCB0} .	I/O
E5	GND	GND	Ground	
F5	7B	DNU	I/O pin not used in this mode. Leave unconnected.	I/O
G5	8B	DNU	I/O pin not used in this mode. Leave unconnected.	I/O
A6	10B1	CLK	Clock signal connected to card	Output
B6	9B1	CMD	Command signal connected to card	Output
C6	2B	DAT1	Data bit 2 connected to card. Referenced to V _{CCB0} .	I/O

SN74AVCA406

MMC, SD CARD, Memory Stick™, SmartMedia, AND xD-Picture Card™
±15-kV ESD-PROTECTED VOLTAGE-TRANSLATION TRANSCEIVER
SCES615B – OCTOBER 2004 – REVISED DECEMBER 2004

Table 2. SD or SDIO Card (Continued)

PIN NO.	PIN NAME	SIGNAL NAME OR (CONNECTION)	PIN FUNCTION	PIN TYPE
D6	11B	DNU	Output pin not used in this mode. Leave unconnected.	Output
E6	10B2	DNU	Output pin not used in this mode. Leave unconnected.	Output
F6	5B	DNU	I/O pin not used in this mode. Leave unconnected.	I/O
G6	6B	DNU	I/O pin not used in this mode. Leave unconnected.	I/O
A7	VCCB0	VCCB0	B-port supply voltage. VCCB0 powers 1B, 2B, 3B, 4B, 9B1, and 10B1.	Power
B7	1B	DAT0	Data bit 1 connected to card. Referenced to VCCB0.	I/O
C7	3B	DAT2	Data bit 3 connected to card. Referenced to VCCB0.	I/O
D7	12B	(tie-low)	Input pin not used in this mode. Tie to GND.	Input
E7	9B2	DNU	I/O pin not used in this mode. Leave unconnected.	I/O
F7	14B	DNU	Open-drain output not used in this mode. Leave unconnected.	Output
G7	VCCB1	(tie-low)	B-port supply voltage. VCCB1 powers 5B, 6B, 7B, 8B, 9B2, 10B2, 11B, 12B, and 14B. Not used in this mode. Tie to GND.	Power

SN74AVCA406

MMC, SD CARD, Memory Stick™, SmartMedia, AND xD-Picture Card™ ±15-kV ESD-PROTECTED VOLTAGE-TRANSLATION TRANSCEIVER

SCES615B – OCTOBER 2004 – REVISED DECEMBER 2004

configuration 1b – interfacing with SD card or MMC (SD 1-bit mode or MMC mode)

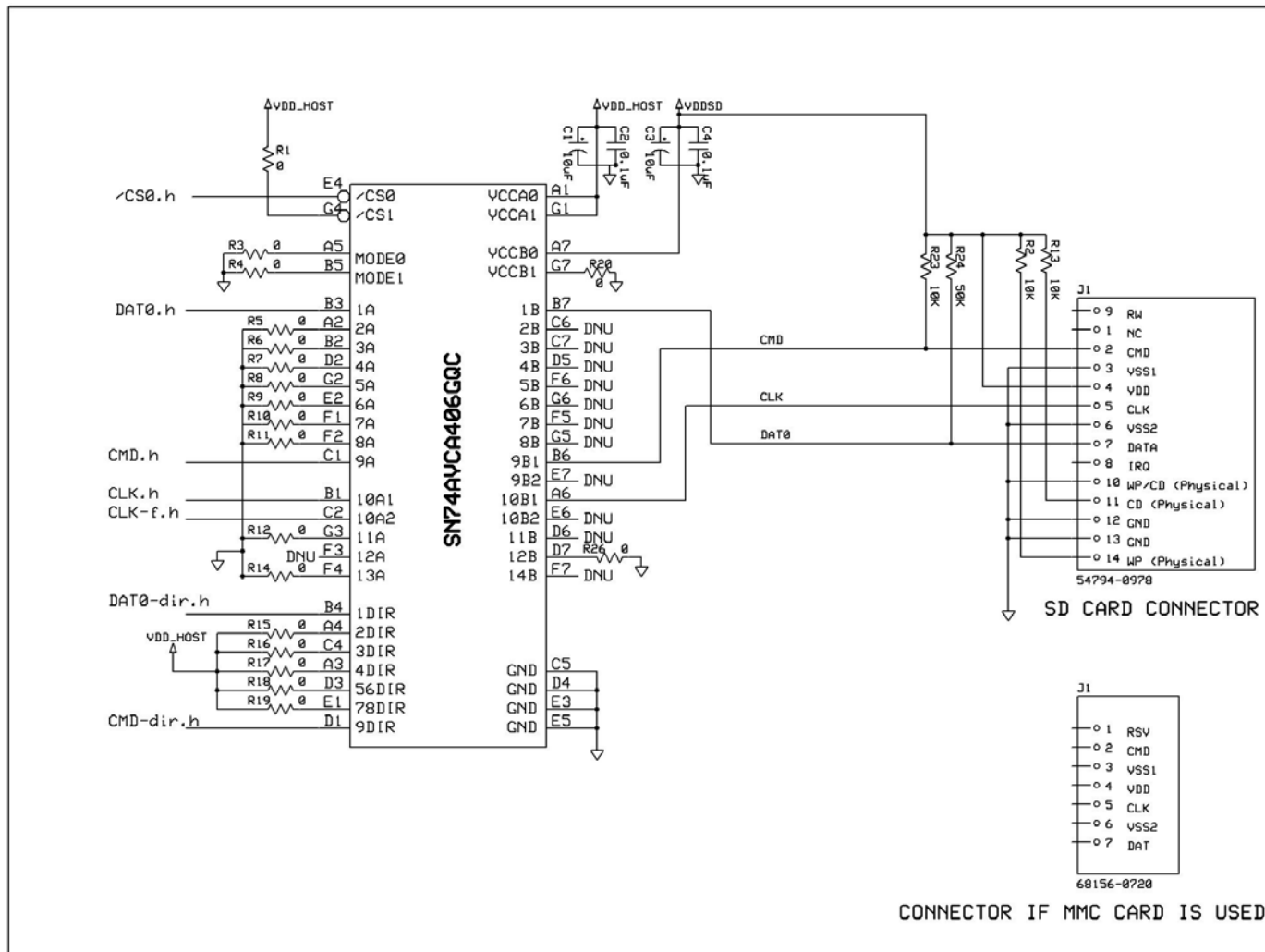

SN74AVCA406

MMC, SD CARD, Memory Stick™, SmartMedia, AND xD-Picture Card™
±15-kV ESD-PROTECTED VOLTAGE-TRANSLATION TRANSCEIVER
SCES615B – OCTOBER 2004 – REVISED DECEMBER 2004

Table 3. SD Card or MMC

PIN NO.	PIN NAME	SIGNAL NAME OR (CONNECTION)	PIN FUNCTION	PIN TYPE
A1	V _{CCA}	V _{CCA}	A-port supply voltage. V _{CCA} powers all A-port I/Os and control inputs.	Power
B1	10A1	CLK.h	Clock signal from host	Input
C1	9A	CMD.h	Command signal connected to host	I/O
D1	9DIR	CMD-dir.h	Direction control for 9A/9B	Input
E1	78DIR	(tie-high)	Direction control for 7A/7B and 8A/8B. Not used in this mode. Tie to V _{CCA} .	Input
F1	7A	(tie-low)	I/O pin not used in this mode. Tie to GND.	I/O
G1	V _{CCA}	V _{CCA}	A-port supply voltage. V _{CCA} powers all A-port I/Os and control inputs.	Power
A2	2A	(tie-low)	I/O pin not used in this mode. Tie to GND.	I/O
B2	3A	(tie-low)	I/O pin not used in this mode. Tie to GND.	I/O
C2	10A2	CLK-f.h	Clock feedback to host for resynchronizing data. Used in OMAP processors. Optional on other processors. Leave unconnected if not used.	Output
D2	4A	(tie-low)	I/O pin not used in this mode. Tie to GND.	I/O
E2	6A	(tie-low)	I/O pin not used in this mode. Tie to GND.	I/O
F2	8A	(tie-low)	I/O pin not used in this mode. Tie to GND.	I/O
G2	5A	(tie-low)	I/O pin not used in this mode. Tie to GND.	I/O
A3	4DIR	(tie-high)	Direction control for 4A/4B. Not used in this mode. Tie to V _{CCA} .	Input
B3	1A	DAT0.h	Data bit 1 connected to host. Referenced to V _{CCA} .	I/O
C3	Depopulated ball			
D3	56DIR	(tie-high)	Direction control for 5A/5B and 6A/6B. Not used in this mode. Tie to V _{CCA} .	Input
E3	GND	GND	Ground	
F3	12A	DNU	Output pin not used in this mode. Do not use. Leave unconnected.	Output
G3	11A	(tie-low)	Input pin not used in this mode. Tie to GND.	Input
A4	2DIR	(tie-high)	Direction control for 2A/2B. Not used in this mode. Tie to V _{CCA} .	Input
B4	1DIR	DAT0-dir.h	Direction control for 1A/1B	Input
C4	3DIR	(tie-high)	Direction control for 3A/3B. Not used in this mode. Tie to V _{CCA} .	Input
D4	GND	GND	Ground	
E4	$\overline{\text{CS0}}$	$\overline{\text{CS0}}$.h	Card select from host. Active low. When $\overline{\text{CS0}}$ = high, 1A, 2A, 3A, 4A, 1B, 2B, 3B, 4B, and 9B1 are placed in Hi Z.	Input
F4	13A	(tie-low)	Input pin not used in this mode. Tie to GND.	Input
G4	$\overline{\text{CS1}}$	(tie-high)	Card select. Not used in this mode. For proper operation tie to V _{CCA} .	Input
A5	MODE1	(tie-low)	MODE1, MODE0 determine mode of operation (see Table 1). Tie to GND in this mode.	Input
B5	MODE0	(tie-low)		Input
C5	GND	GND	Ground	
D5	4B	DNU	I/O pin not used in this mode. Leave unconnected.	I/O
E5	GND	GND	Ground	
F5	7B	DNU	I/O pin not used in this mode. Leave unconnected.	I/O
G5	8B	DNU	I/O pin not used in this mode. Leave unconnected.	I/O
A6	10B1	CLK	Clock signal connected to card	Output
B6	9B1	CMD	Command signal connected to card	Output
C6	2B	DNU	I/O pin not used in this mode. Leave unconnected.	I/O
D6	11B	DNU	Output pin not used in this mode. Leave unconnected.	Output
E6	10B2	DNU	Output pin not used in this mode. Leave unconnected.	Output
F6	5B	DNU	I/O pin not used in this mode. Leave unconnected.	I/O



SN74AVCA406**MMC, SD CARD, Memory Stick™, SmartMedia, AND xD-Picture Card™****±15-kV ESD-PROTECTED VOLTAGE-TRANSLATION TRANSCEIVER**

SCES615B – OCTOBER 2004 – REVISED DECEMBER 2004

Table 3. SD Card or MMC (Continued)

PIN NO.	PIN NAME	SIGNAL NAME OR (CONNECTION)	PIN FUNCTION	PIN TYPE
G6	6B	DNU	I/O pin not used in this mode. Leave unconnected.	I/O
A7	VCCB0	VCCB0	B-port supply voltage. VCCB0 powers 1B, 2B, 3B, 4B, 9B1, and 10B1.	Power
B7	1B	DAT0	Data bit 1 connected to card. Referenced to VCCB0.	I/O
C7	3B	DNU	I/O pin not used in this mode. Leave unconnected.	I/O
D7	12B	(tie-low)	Input pin not used in this mode. Tie to GND.	Input
E7	9B2	DNU	I/O pin not used in this mode. Leave unconnected.	I/O
F7	14B	DNU	Open-drain output not used in this mode. Leave unconnected.	Output
G7	VCCB1	(tie-low)	B-port supply voltage. VCCB1 powers 5B, 6B, 7B, 8B, 9B2, 10B2, 11B, 12B, and 14B. Not used in this mode. Tie to GND.	Power

SN74AVCA406
MMC, SD CARD, Memory Stick™, SmartMedia, AND xD-Picture Card™
±15-kV ESD-PROTECTED VOLTAGE-TRANSLATION TRANSCEIVER

SCES615B – OCTOBER 2004 – REVISED DECEMBER 2004

configuration 1c – interfacing with SD/SDIO card or MMC (SPI mode)

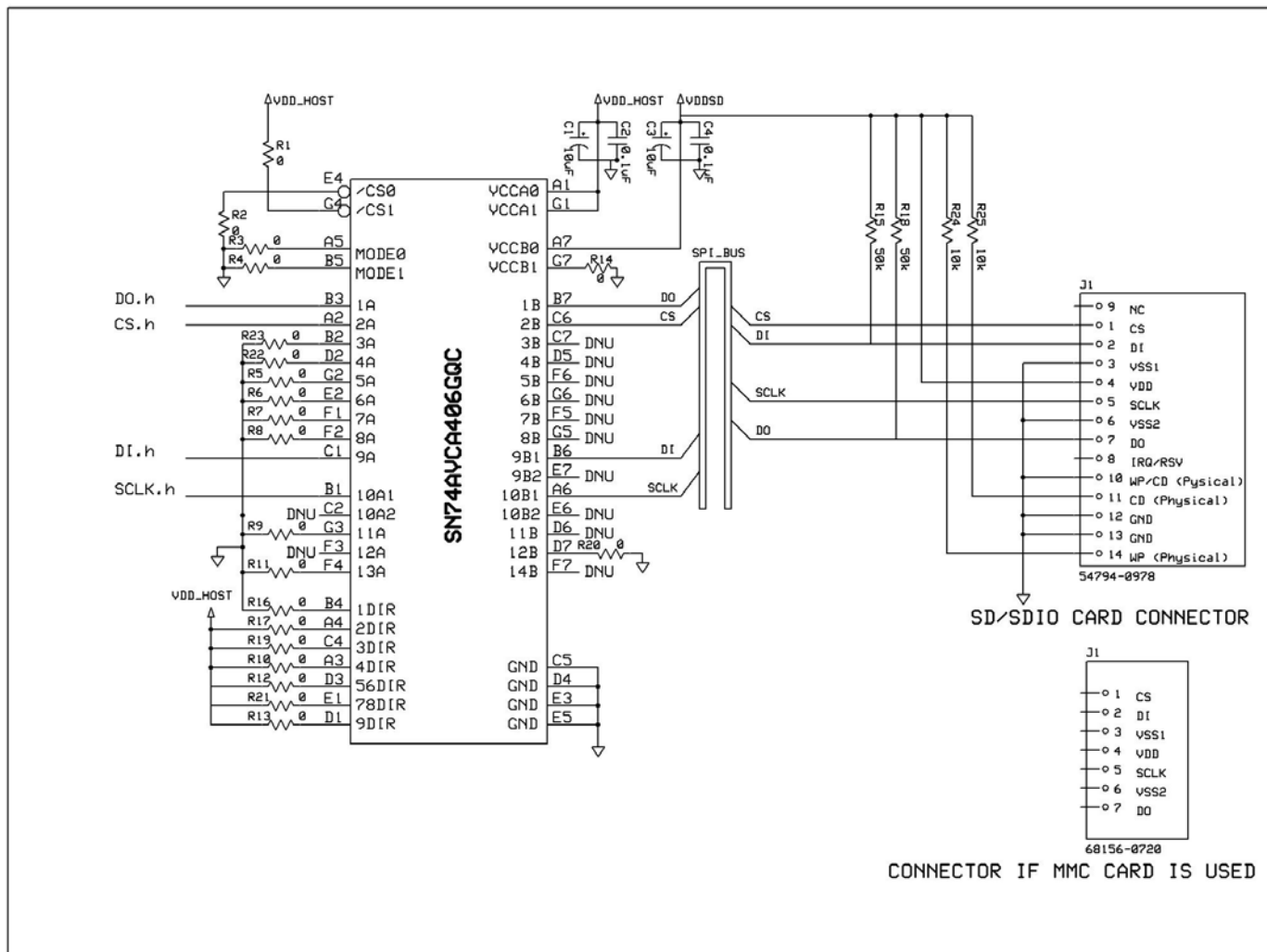

SN74AVCA406
MMC, SD CARD, Memory Stick™, SmartMedia, AND xD-Picture Card™
±15-kV ESD-PROTECTED VOLTAGE-TRANSLATION TRANSCEIVER

SCES615B – OCTOBER 2004 – REVISED DECEMBER 2004

Table 4. SD/SDIO Card or MMC

PIN NO.	PIN NAME	SIGNAL NAME OR (CONNECTION)	PIN FUNCTION	PIN TYPE
A1	V _{CCA}	V _{CCA}	A-port supply voltage. V _{CCA} powers all A-port I/Os and control inputs.	Power
B1	10A1	SCLK.h	Serial clock signal from host	Input
C1	9A	DI.h	Serial data in (master out slave in) connected to host. Connect 9DIR to V _{CCA} to make 9A an input.	I/O
D1	9DIR	(tie-high)	Direction control for 9A/9B. Tie high to make 9A an input and 9B an output.	Input
E1	78DIR	(tie-high)	Direction control for 7A/7B and 8A/8B. Not used in this mode. Tie to V _{CCA} .	Input
F1	7A	(tie-low)	I/O pin not used in this mode. Tie to GND.	I/O
G1	V _{CCA}	V _{CCA}	A-port supply voltage. V _{CCA} powers all A-port I/Os and control inputs.	Power
A2	2A	CS.h	Card select connected to host. Connect 2DIR to V _{CCA} to make 2A an input.	I/O
B2	3A	(tie-low)	I/O pin not used in this mode. Tie to GND.	I/O
C2	10A2	DNU	Clock feedback to host. Not used in this mode. Leave unconnected.	Output
D2	4A	(tie-low)	I/O pin not used in this mode. Tie to GND.	I/O
E2	6A	(tie-low)	I/O pin not used in this mode. Tie to GND.	I/O
F2	8A	(tie-low)	I/O pin not used in this mode. Tie to GND.	I/O
G2	5A	(tie-low)	I/O pin not used in this mode. Tie to GND.	I/O
A3	4DIR	(tie-high)	Direction control for 4A/4B. Not used in this mode. Tie to V _{CCA} .	Input
B3	1A	DO.h	Serial data out (master in slave out) connected to host. Connect 1DIR to GND to make 1A an output.	I/O
C3	Depopulated ball			
D3	56DIR	(tie-high)	Direction control for 5A/5B and 6A/6B. Not used in this mode. Tie to V _{CCA} .	Input
E3	GND	GND	Ground	
F3	12A	DNU	Output pin not used in this mode. Do not use. Leave unconnected.	Output
G3	11A	(tie-low)	Input pin not used in this mode. Tie to GND.	Input
A4	2DIR	(tie-high)	Direction control for 2A/2B. Tie to V _{CCA} to make 2A an input and 2B an output.	Input
B4	1DIR	(tie-low)	Direction control for 1A/1B. Tie to GND to make 1B an input and 1A an output.	Input
C4	3DIR	(tie-high)	Direction control for 3A/3B. Not used in this mode. Tie to V _{CCA} .	Input
D4	GND	GND	Ground	
E4	CS ₀	(tie-low)	Card select signal. Not used in this mode. For proper operation, tie to GND.	Input
F4	13A	(tie-low)	Input pin not used in this mode. Tie to GND.	Input
G4	CS ₁	(tie-high)	Card select. Not used in this mode. For proper operation, tie to V _{CCA} .	Input
A5	MODE1	(tie-low)	MODE1, MODE0 determine mode of operation (see Table 1). Tie to GND in this mode.	Input
B5	MODE0	(tie-low)		Input
C5	GND	GND	Ground	
D5	4B	DNU	Card select connected to card. Connect 2DIR to V _{CCA} to make 2B an output.	I/O
E5	GND	GND	Ground	
F5	7B	DNU	I/O pin not used in this mode. Leave unconnected.	I/O
G5	8B	DNU	I/O pin not used in this mode. Leave unconnected.	I/O
A6	10B1	SCLK	Serial clock signal connected to card	Output
B6	9B1	DI	Serial data in (master out slave in) connected to card	Output
C6	2B	CS	I/O pin not used in this mode. Leave unconnected.	I/O
D6	11B	DNU	Output pin not used in this mode. Leave unconnected.	Output
E6	10B2	DNU	Output pin not used in this mode. Leave unconnected.	Output
F6	5B	DNU	I/O pin not used in this mode. Leave unconnected.	I/O



SN74AVCA406

MMC, SD CARD, Memory Stick™, SmartMedia, AND xD-Picture Card™
±15-kV ESD-PROTECTED VOLTAGE-TRANSLATION TRANSCEIVER
SCES615B – OCTOBER 2004 – REVISED DECEMBER 2004

Table 4. SD/SDIO Card or MMC (Continued)

PIN NO.	PIN NAME	SIGNAL NAME OR (CONNECTION)	PIN FUNCTION	PIN TYPE
G6	6B	DNU	I/O pin not used in this mode. Leave unconnected.	I/O
A7	VCCB0	VCCB0	B-port supply voltage. VCCB0 powers 1B, 2B, 3B, 4B, 9B1, and 10B1.	Power
B7	1B	DO	Serial data out (master in slave out) connected to host. Connect 1DIR to GND to make 1B an input.	I/O
C7	3B	DNU	I/O pin not used in this mode. Leave unconnected.	I/O
D7	12B	(tie-low)	Input pin not used in this mode. Tie to GND.	Input
E7	9B2	DNU	I/O pin not used in this mode. Leave unconnected.	I/O
F7	14B	DNU	Open-drain output not used in this mode. Leave unconnected.	Output
G7	VCCB1	(tie-low)	B-port supply voltage. VCCB1 powers 5B, 6B, 7B, 8B, 9B2, 10B2, 11B, 12B, and 14B. Not used in this mode. Tie to GND.	Power

SN74AVCA406

MMC, SD CARD, Memory Stick™, SmartMedia, AND xD-Picture Card™ ±15-kV ESD-PROTECTED VOLTAGE-TRANSLATION TRANSCEIVER

SCES615B – OCTOBER 2004 – REVISED DECEMBER 2004

configuration 1d – interfacing with SDIO card in slot 0 and SD card (4-bit mode) in slot 1

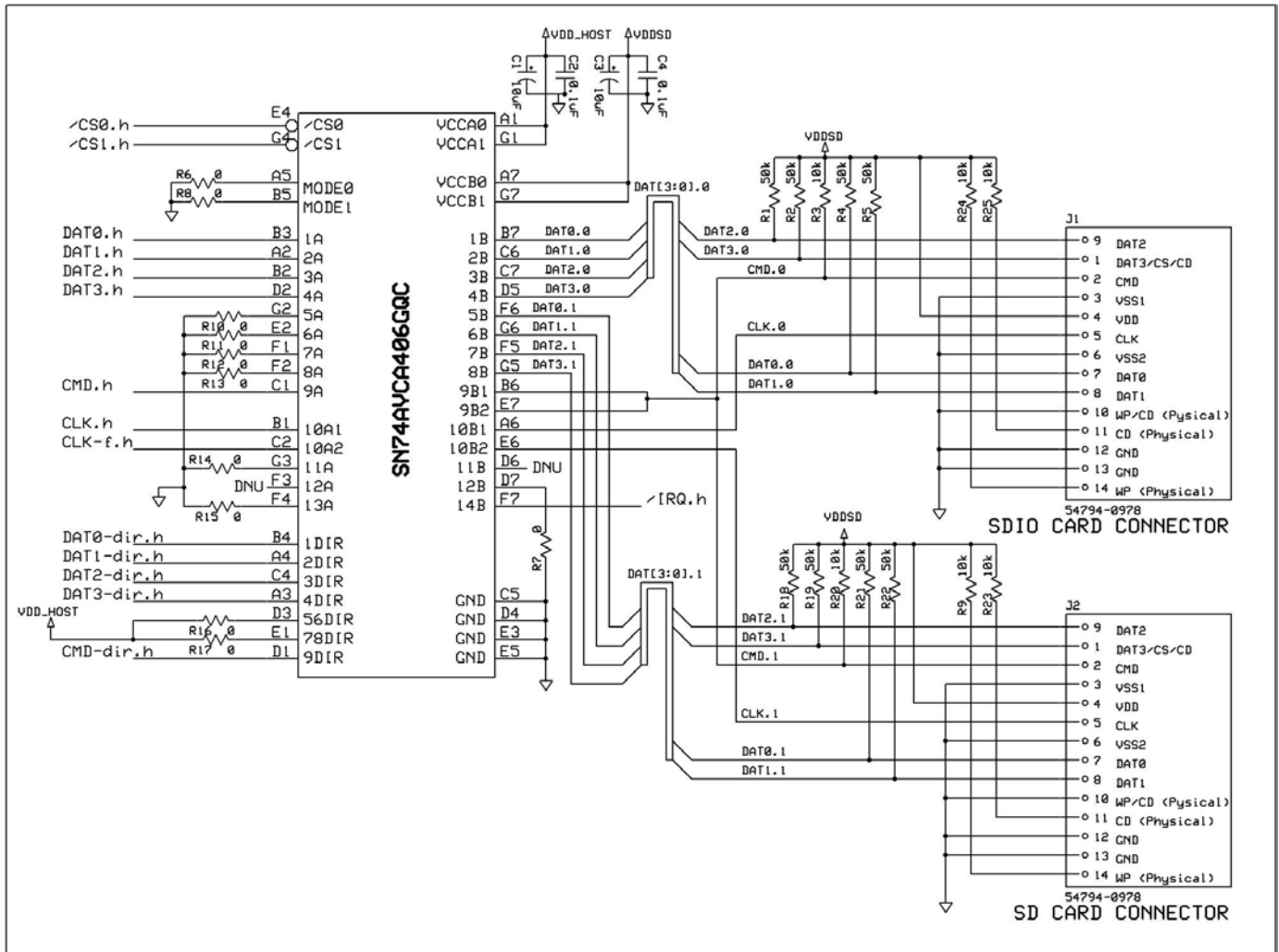

SN74AVCA406

MMC, SD CARD, Memory Stick™, SmartMedia, AND xD-Picture Card™
±15-kV ESD-PROTECTED VOLTAGE-TRANSLATION TRANSCEIVER
SCES615B – OCTOBER 2004 – REVISED DECEMBER 2004

Table 5. SDIO Card (Slot 0) and SD Card (Slot 1)

PIN NO.	PIN NAME	SIGNAL NAME OR (CONNECTION)	PIN FUNCTION	PIN TYPE
A1	V _{CCA}	V _{CCA}	A-port supply voltage. V _{CCA} powers all A-port I/Os and control inputs.	Power
B1	10A1	CLK.h	Clock signal from host	Input
C1	9A	CMD.h	Command signal connected to host	I/O
D1	9DIR	CMD-dir.h	Direction control for 9A/9B connected to host	Input
E1	78DIR	(tie-high)	Direction control for 7A/7B and 8A/8B. Not used in this mode. Tie to V _{CCA} .	Input
F1	7A	(tie-low)	I/O pin not used in this mode. Tie to GND.	I/O
G1	V _{CCA}	V _{CCA}	A-port supply voltage. V _{CCA} powers all A-port I/Os and control inputs.	Power
A2	2A	DAT1.h	Data bit 2 connected to host. Referenced to V _{CCA} .	I/O
B2	3A	DAT2.h	Data bit 3 connected to host. Referenced to V _{CCA} .	I/O
C2	10A2	CLK-f.h	Clock feedback to host for resynchronizing data. Used in OMAP processors. Optional on other processors. Leave unconnected if not used.	Output
D2	4A	DAT3.h	Data bit 4 connected to host. Referenced to V _{CCA} .	I/O
E2	6A	(tie-low)	I/O pin not used in this mode. Tie to GND.	I/O
F2	8A	(tie-low)	I/O pin not used in this mode. Tie to GND.	I/O
G2	5A	(tie-low)	I/O pin not used in this mode. Tie to GND.	I/O
A3	4DIR	DAT3-dir.h	Direction control for 4A/4B	Input
B3	1A	DAT0.h	Data bit 1 connected to host. Referenced to V _{CCA} .	I/O
C3	Depopulated ball			
D3	56DIR	(tie-high)	Direction control for 5A/5B and 6A/6B. Not used in this mode. Tie to V _{CCA} .	Input
E3	GND	GND	Ground	
F3	12A	DNU	Output pin not used in this mode. Do not use. Leave unconnected.	Output
G3	11A	(tie-low)	Input pin not used in this mode. Tie to GND.	Input
A4	2DIR	DAT1-dir.h	Direction control for 2A/2B connected to host	Input
B4	1DIR	DAT0-dir.h	Direction control for 1A/1B connected to host	Input
C4	3DIR	DAT2-dir.h	Direction control for 3A/3B connected to host	Input
D4	GND	GND	Ground	
E4	$\overline{\text{CS0}}$	$\overline{\text{CS0}}$.h	Card select from host. Active low. When $\overline{\text{CS0}}$ = high, 1A, 2A, 3A, 4A, 1B, 2B, 3B, 4B, and 9B1 are placed in Hi Z, and 10B1 is low.	Input
F4	13A	(tie-low)	Input pin not used in this mode. Tie to GND.	Input
G4	$\overline{\text{CS1}}$	$\overline{\text{CS1}}$.h	Card select from host. Active low. When $\overline{\text{CS1}}$ = high, 5A, 6A, 7A, 8A, 5B, 6B, 7B, 8B, 7B, and 9B2 are placed in Hi Z, and 10B2 is low.	Input
A5	MODE1	(tie-low)	MODE1, MODE0 determine mode of operation (see Table 1). Tie to GND in this mode.	Input
B5	MODE0	(tie-low)		Input
C5	GND	GND	Ground	
D5	4B	DAT3.0	Data bit 4 connected to card in slot 0. Referenced to V _{CCB0} .	I/O
E5	GND	GND	Ground	
F5	7B	DAT2.1	Data bit 3 connected to card in slot 1. Referenced to V _{CCB1} .	I/O
G5	8B	DAT3.1	Data bit 4 connected to card in slot 1. Referenced to V _{CCB1} .	I/O
A6	10B1	CLK.0	Clock signal connected to card in slot 0	Output
B6	9B1	CMD.0	Command signal connected to card in slot 0	Output
C6	2B	DAT1.0	Data bit 2 connected to card in slot 0. Referenced to V _{CCB0} .	I/O
D6	11B	DNU	Output pin not used in this mode. Leave unconnected.	Output
E6	10B2	CLK.1	Clock signal connected to card in slot 1	Output

SN74AVCA406**MMC, SD CARD, Memory Stick™, SmartMedia, AND xD-Picture Card™
±15-kV ESD-PROTECTED VOLTAGE-TRANSLATION TRANSCEIVER**

SCES615B – OCTOBER 2004 – REVISED DECEMBER 2004

Table 5. SDIO Card (Slot 0) and SD Card (Slot 1) (Continued)

PIN NO.	PIN NAME	SIGNAL NAME OR (CONNECTION)	PIN FUNCTION	PIN TYPE
F6	5B	DAT0.1	Data bit 1 connected to card in slot 1. Referenced to V _{CCB1} .	I/O
G6	6B	DAT1.1	Data bit 2 connected to card in slot 1. Referenced to V _{CCB1} .	I/O
A7	V _{CCB0}	V _{CCB0}	B-port supply voltage. V _{CCB0} powers 1B, 2B, 3B, 4B, 9B1, and 10B1.	Power
B7	1B	DAT0.0	Data bit 1 connected to card in slot 0. Referenced to V _{CCB0} .	I/O
C7	3B	DAT2.0	Data bit 3 connected to card in slot 0. Referenced to V _{CCB0} .	I/O
D7	12B	(tie-low)	Input pin not used in this mode. Tie to GND.	Input
E7	9B2	CMD.1	Command signal connected to card in slot 1	I/O
F7	14B	/IRQ.h	Open-drain interrupt output for dual SDIO cards configuration. DAT1 is the input for interrupt.	Output
G7	V _{CCB1}	V _{CCB1}	B-port supply voltage. V _{CCB1} powers 5B, 6B, 7B, 8B, 9B2, 10B2, 11B, 12B, and 14B.	Power

SN74AVCA406
MMC, SD CARD, Memory Stick™, SmartMedia, AND xD-Picture Card™
±15-kV ESD-PROTECTED VOLTAGE-TRANSLATION TRANSCEIVER

SCES615B – OCTOBER 2004 – REVISED DECEMBER 2004

**configuration 1e – alternate method of interfacing with SD/SDIO card
 (SD mode or SD 4-bit mode)**

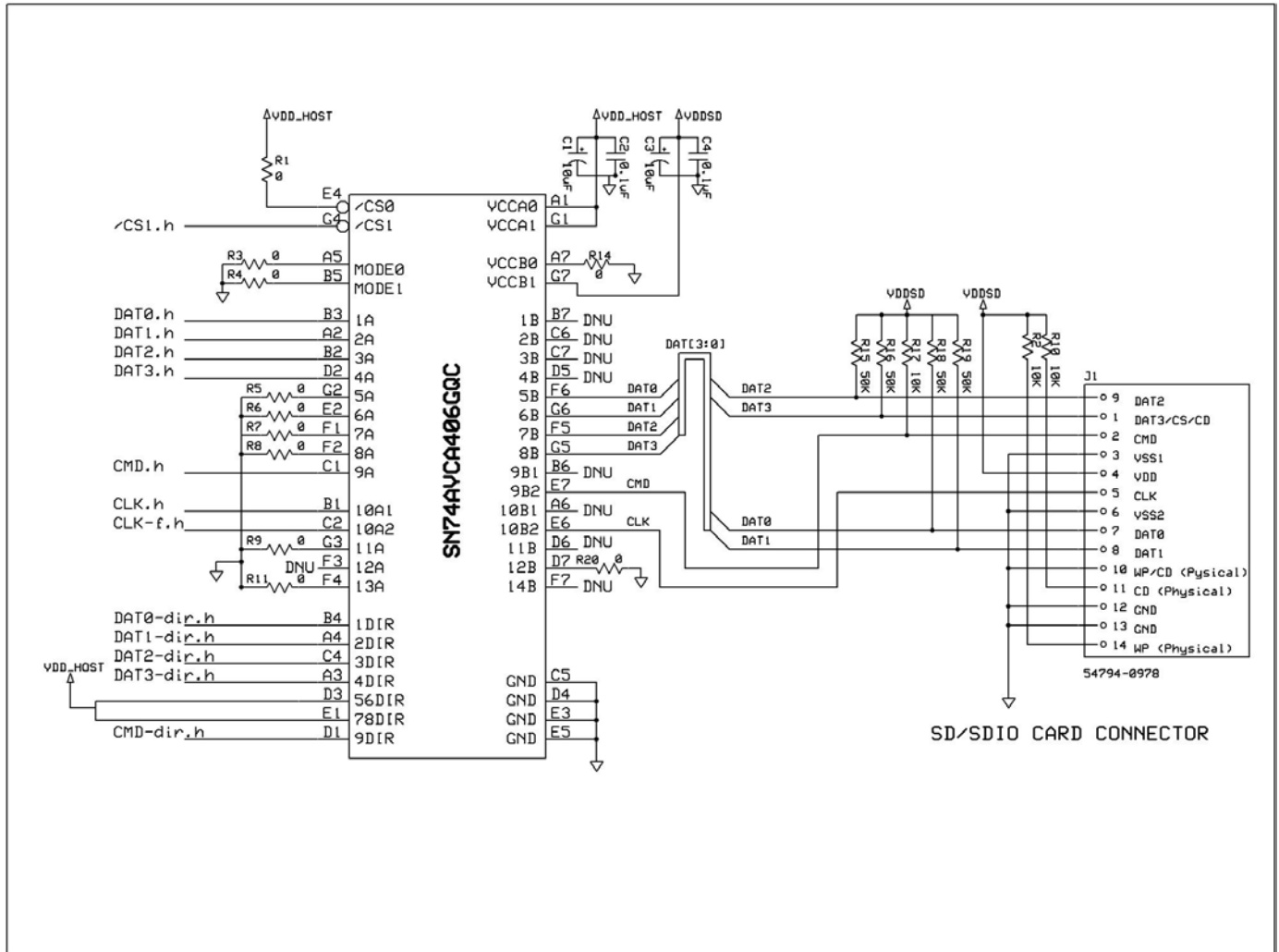

SN74AVCA406
**MMC, SD CARD, Memory Stick™, SmartMedia, AND xD-Picture Card™
±15-kV ESD-PROTECTED VOLTAGE-TRANSLATION TRANSCEIVER**

SCES615B – OCTOBER 2004 – REVISED DECEMBER 2004

Table 6. Alternate SD/SDIO Card

PIN NO.	PIN NAME	SIGNAL NAME OR (CONNECTION)	PIN FUNCTION	PIN TYPE
A1	V _{CCA}	V _{CCA}	A-port supply voltage. V _{CCA} powers all A-port I/Os and control inputs.	Power
B1	10A1	CLK.h	Clock signal from host	Input
C1	9A	CMD.h	Command signal connected to host	I/O
D1	9DIR	CMD-dir.h	Direction control for 9A/9B connected to host	Input
E1	78DIR	(tie-high)	Direction control for 7A/7B and 8A/8B. Not used in this mode. Tie to V _{CCA} .	Input
F1	7A	(tie-low)	I/O pin not used in this mode. Tie to GND.	I/O
G1	V _{CCA}	V _{CCA}	A-port supply voltage. V _{CCA} powers all A-port I/Os and control inputs.	Power
A2	2A	DAT1.h	Data bit 2 connected to host. Referenced to V _{CCA} .	I/O
B2	3A	DAT2.h	Data bit 3 connected to host. Referenced to V _{CCA} .	I/O
C2	10A2	CLK-f.h	Clock feedback to host for resynchronizing data. Used in OMAP processors. Optional on other processors. Leave unconnected if not used.	Output
D2	4A	DAT3.h	Data bit 4 connected to host. Referenced to V _{CCA} .	I/O
E2	6A	(tie-low)	I/O pin not used in this mode. Tie to GND.	I/O
F2	8A	(tie-low)	I/O pin not used in this mode. Tie to GND.	I/O
G2	5A	(tie-low)	I/O pin not used in this mode. Tie to GND.	I/O
A3	4DIR	DAT3-dir.h	Direction control for 4A/4B	Input
B3	1A	DAT0.h	Data bit 1 connected to host. Referenced to V _{CCA} .	I/O
C3			Depopulated ball	
D3	56DIR	(tie-high)	Direction control for 5A/5B and 6A/6B. Not used in this mode. Tie to V _{CCA} .	Input
E3	GND	GND	Ground	
F3	12A	DNU	Output pin not used in this mode. Do not use. Leave unconnected.	Output
G3	11A	(tie-low)	Input pin not used in this mode. Tie to GND.	Input
A4	2DIR	DAT1-dir.h	Direction control for 2A/2B connected to host	Input
B4	1DIR	DAT0-dir.h	Direction control for 1A/1B connected to host	Input
C4	3DIR	DAT2-dir.h	Direction control for 3A/3B connected to host	Input
D4	GND	GND	Ground	
E4	$\overline{\text{CS0}}$	(tie-high)	Card select signal. Not used in this mode. Tie to V _{CCA} for proper operation.	Input
F4	13A	(tie-low)	Input pin not used in this mode. Tie to GND.	Input
G4	$\overline{\text{CS1}}$	$\overline{\text{CS1}}$	Card select from host. Active low. When $\overline{\text{CS1}}$ = high, 1A, 2A, 3A, 4A, 5B, 6B, 7B, 8B, 9A, 9B2, and 10A2 are placed in Hi Z and 10B1 is low.	Input
A5	MODE1	(tie-low)	MODE1, MODE0 determine mode of operation (see Table 1). Tie to GND in this mode.	Input
B5	MODE0	(tie-low)		Input
C5	GND	GND	Ground	
D5	4B	DNU	I/O pin not used in this mode. Leave unconnected.	I/O
E5	GND	GND	Ground	
F5	7B	DAT2	Data bit 3 connected to card. Referenced to V _{CCB1} .	I/O
G5	8B	DAT3	Data bit 4 connected to card. Referenced to V _{CCB1} .	I/O
A6	10B1	DNU	Output pin not used in this mode. Leave unconnected.	Output
B6	9B1	DNU	Output pin not used in this mode. Leave unconnected.	Output
C6	2B	DNU	I/O pin not used in this mode. Leave unconnected.	I/O



SN74AVCA406

MMC, SD CARD, Memory Stick™, SmartMedia, AND xD-Picture Card™
±15-kV ESD-PROTECTED VOLTAGE-TRANSLATION TRANSCEIVER

SCES615B – OCTOBER 2004 – REVISED DECEMBER 2004

Table 6. Alternate SD/SDIO Card (Continued)

PIN NO.	PIN NAME	SIGNAL NAME OR (CONNECTION)	PIN FUNCTION	PIN TYPE
D6	11B	DNU	Output pin not used in this mode. Leave unconnected.	Output
E6	10B2	CLK	Clock signal connected to card	Output
F6	5B	DAT0	Data bit 1 connected to card. Referenced to V_{CCB1} .	I/O
G6	6B	DAT1	Data bit 2 connected to card. Referenced to V_{CCB1} .	I/O
A7	V_{CCB0}	(tie-low)	B-port supply voltage. V_{CCB0} powers 1B, 2B, 3B, 4B, 9B1, and 10B1. Not used in this mode. Tie to GND.	Power
B7	1B	DNU	I/O pin not used in this mode. Leave unconnected.	I/O
C7	3B	DNU	I/O pin not used in this mode. Leave unconnected.	I/O
D7	12B	(tie-low)	Input pin not used in this mode. Tie to GND.	Input
E7	9B2	CMD	Command signal connected to card	I/O
F7	14B	DNU	Open-drain output not used in this mode. Leave unconnected.	Output
G7	V_{CCB1}	V_{CCB1}	B-port supply voltage. V_{CCB1} powers 5B, 6B, 7B, 8B, 9B2, 10B2, 11B, 12B, and 14B.	Power

SN74AVCA406

MMC, SD CARD, Memory Stick™, SmartMedia, AND xD-Picture Card™ ±15-kV ESD-PROTECTED VOLTAGE-TRANSLATION TRANSCEIVER

SCES615B – OCTOBER 2004 – REVISED DECEMBER 2004

configuration 1f – interfacing with Memory Stick

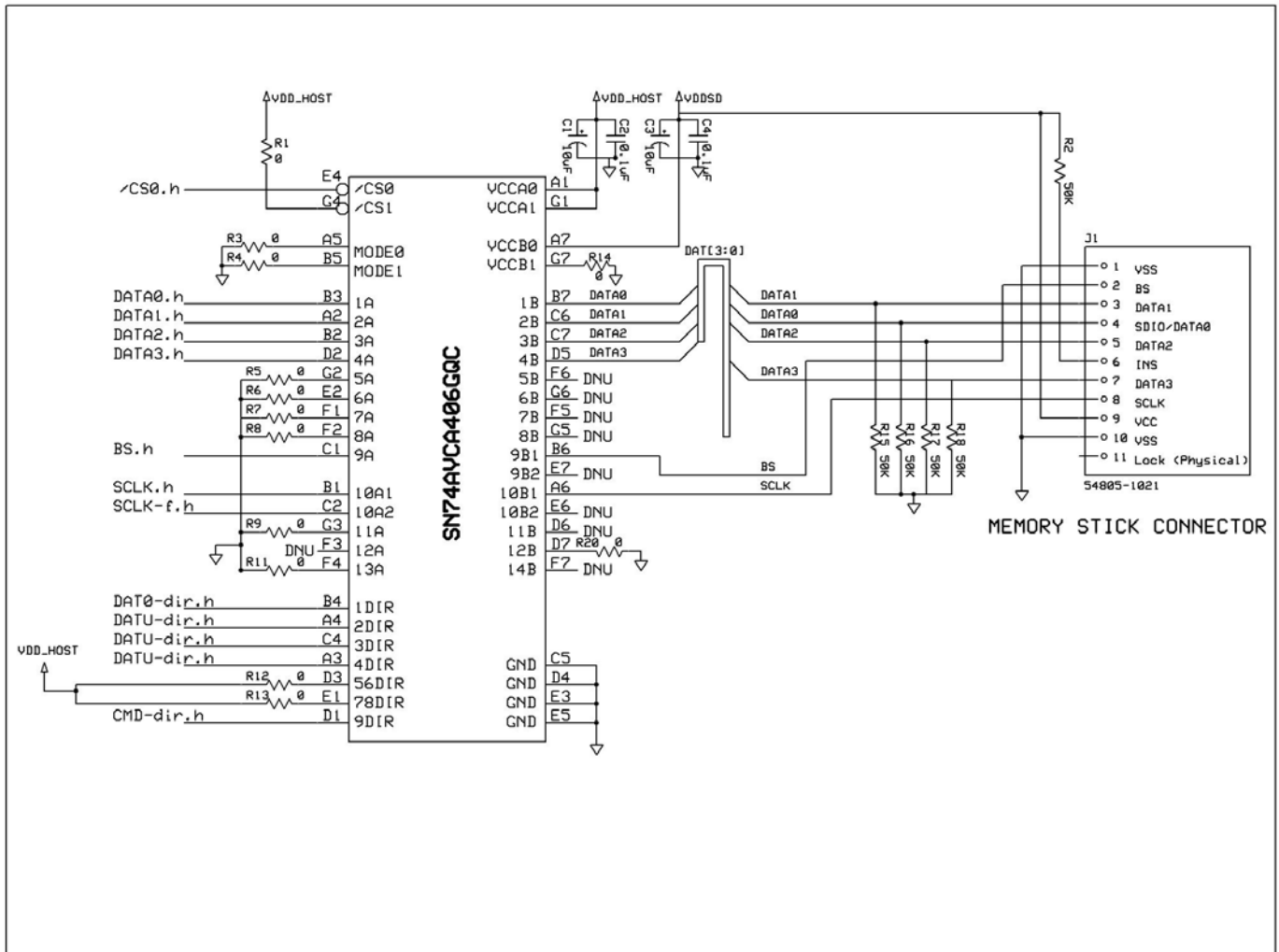

SN74AVCA406

MMC, SD CARD, Memory Stick™, SmartMedia, AND xD-Picture Card™
±15-kV ESD-PROTECTED VOLTAGE-TRANSLATION TRANSCEIVER
SCES615B – OCTOBER 2004 – REVISED DECEMBER 2004

Table 7. Memory Stick

PIN NO.	PIN NAME	SIGNAL NAME OR (CONNECTION)	PIN FUNCTION	PIN TYPE
A1	V _{CCA}	V _{CCA}	A-port supply voltage. V _{CCA} powers all A-port I/Os and control inputs.	Power
B1	10A1	SCLK.h	Clock signal from host	Input
C1	9A	BS.h	Bus state connected to host	I/O
D1	9DIR	(tie-high)	Direction control for 9A/9B connected to host. Tie high to make 9A an input, 9B an output.	Input
E1	78DIR	(tie-high)	Direction control for 7A/7B and 8A/8B. Not used in this mode. Tie to V _{CCA} .	Input
F1	7A	(tie-low)	I/O pin not used in this mode. Tie to GND.	I/O
G1	V _{CCA}	V _{CCA}	A-port supply voltage. V _{CCA} powers all A-port I/Os and control inputs.	Power
A2	2A	DATA1.h	Data bit 2 connected to host. Referenced to V _{CCA} .	I/O
B2	3A	DATA2.h	Data bit 3 connected to host. Referenced to V _{CCA} .	I/O
C2	10A2	SCLK-f.h	Clock feedback to host for resynchronizing data. Used in OMAP processors. Optional on other processors. Leave unconnected if not used.	Output
D2	4A	DATA3.h	Data bit 4 connected to host. Referenced to V _{CCA} .	I/O
E2	6A	(tie-low)	I/O pin not used in this mode. Tie to GND.	I/O
F2	8A	(tie-low)	I/O pin not used in this mode. Tie to GND.	I/O
G2	5A	(tie-low)	I/O pin not used in this mode. Tie to GND.	I/O
A3	4DIR	DATU-dir.h	Direction control for 4A/4B	Input
B3	1A	DATA0.h	Data bit 1 connected to host. Referenced to V _{CCA} .	I/O
C3	Depopulated ball			
D3	56DIR	(tie-high)	Direction control for 5A/5B and 6A/6B. Not used in this mode. Tie to V _{CCA} .	Input
E3	GND	GND	Ground	
F3	12A	DNU	Output pin not used in this mode. Do not use. Leave unconnected.	Output
G3	11A	(tie-low)	Input pin not used in this mode. Tie to GND.	Input
A4	2DIR	DATU-dir.h	Direction control for 2A/2B connected to host	Input
B4	1DIR	DAT0-dir.h	Direction control for 1A/1B connected to host	Input
C4	3DIR	DATU-dir.h	Direction control for 3A/3B connected to host	Input
D4	GND	GND	Ground	
E4	$\overline{\text{CS0}}$	$\overline{\text{CS0}}$.h	Card select from host. Active low. When CS0 = high, 1A, 2A, 3A, 4A, 1B, 2B, 3B, 4B, 9A, 9B1, and 10A2 are placed in Hi Z and 10B1 is low.	Input
F4	13A	(tie-low)	Input pin not used in this mode. Tie to GND.	Input
G4	$\overline{\text{CS1}}$	(tie-high)	Card select signal. Not used in this mode. Tie to V _{CCA} for proper operation.	Input
A5	MODE1	(tie-low)	MODE1, MODE0 determine mode of operation (see Table 1). Tie to GND in this mode.	Input
B5	MODE0	(tie-low)		Input
C5	GND	GND	Ground	
D5	4B	DATA3	Data bit 4 connected to card. Referenced to V _{CCB0} .	I/O
E5	GND	GND	Ground	
F5	7B	DNU	I/O pin not used in this mode. Leave unconnected.	I/O
G5	8B	DNU	I/O pin not used in this mode. Leave unconnected.	I/O
A6	10B1	SCLK	Clock signal connected to card	Output
B6	9B1	BS	Bus state signal connected to card	Output
C6	2B	DATA1	Data bit 2 connected to card. Referenced to V _{CCB0} .	I/O

SN74AVCA406**MMC, SD CARD, Memory Stick™, SmartMedia, AND xD-Picture Card™****±15-kV ESD-PROTECTED VOLTAGE-TRANSLATION TRANSCEIVER**

SCES615B – OCTOBER 2004 – REVISED DECEMBER 2004

Table 7. Memory Stick (Continued)

PIN NO.	PIN NAME	SIGNAL NAME OR (CONNECTION)	PIN FUNCTION	PIN TYPE
D6	11B	DNU	Output pin not used in this mode. Leave unconnected.	Output
E6	10B2	DNU	Output pin not used in this mode. Leave unconnected.	Output
F6	5B	DNU	I/O pin not used in this mode. Leave unconnected.	I/O
G6	6B	DNU	I/O pin not used in this mode. Leave unconnected.	I/O
A7	VCCB0	VCCB0	B-port supply voltage. VCCB0 powers 1B, 2B, 3B, 4B, 9B1, and 10B1.	Power
B7	1B	DATA0	Data bit 1 connected to card. Referenced to VCCB0.	I/O
C7	3B	DATA2	Data bit 3 connected to card. Referenced to VCCB0.	I/O
D7	12B	(tie-low)	Input pin not used in this mode. Tie to GND.	Input
E7	9B2	DNU	I/O pin not used in this mode. Leave unconnected.	I/O
F7	14B	DNU	Open-drain output not used in this mode. Leave unconnected.	Output
G7	VCCB1	(tie-low)	B-port supply voltage. VCCB1 powers 5B, 6B, 7B, 8B, 9B2, 10B2, 11B, 12B, and 14B. Not used in this mode. Tie to GND.	Power

SN74AVCA406

MMC, SD CARD, Memory Stick™, SmartMedia, AND xD-Picture Card™
±15-kV ESD-PROTECTED VOLTAGE-TRANSLATION TRANSCEIVER

SCES615B – OCTOBER 2004 – REVISED DECEMBER 2004

CONFIGURATION 1 FUNCTION TABLE
(MODE0 = L, MODE1 = L)

SIGNAL	INPUTS				OPERATION	
	$\overline{\text{CS0}}$	$\overline{\text{CS1}}$	9DIR	(1-4)DIR	MMC/SD	Memory Stick/ Memory Stick PRO
Clock	H	H	X	X	CLK.0 and CLK.1 forced low, CLK-f.h forced Hi Z	SCLK.0 and SCLK.1 forced low, SCLK-f.h forced Hi Z
	L	L	X	X	CLK.h to CLK.0 and CLK.1, CLK.0 to CLK-f.h	SCLK.h to SCLK.0 and SCLK.1, SCLK.0 to SCLK-f.h
	L	H	X	X	CLK.h to CLK.0, CLK.0 to CLK-f.h, CLK.1 forced low	SCLK.h to SCLK.0, SCLK.0 to SCLK-f.h, SCLK.1 forced low
	H	L	X	X	CLK.h to CLK.1, CLK.1 to CLK-f.h, CLK.0 forced low	SCLK.h to SCLK.1, SCLK.1 to SCLK-f.h, SCLK.0 forced low
Data	H	H	X	X	All data I/Os are Hi Z (isolation mode).	All data I/Os are Hi Z (isolation mode).
	L†	L†	X	L	DAT0.0 and DAT0.1 to DAT0.h, DAT1.0 and DAT1.1 to DAT1.h, DAT2.0 and DAT2.1 to DAT2.h, DAT3.0 and DAT3.1 to DAT3.h	DATA0.0 and DATA0.1 to DATA0.h, DATA1.0 and DATA1.1 to DATA1.h, DATA2.0 and DATA2.1 to DATA2.h, DATA3.0 and DATA3.1 to DATA3.h
	L†	L†	X	H	DAT0.h to DAT0.0 and to DAT0.1, DAT1.h to DAT1.0 and to DAT1.1, DAT2.h to DAT2.0 and to DAT2.1, DAT3.h to DAT3.0 and to DAT3.1	DATA0.h to DATA0.0 and to DATA0.1, DATA1.h to DATA1.0 and to DATA1.1, DATA2.h to DATA2.0 and to DATA2.1, DATA3.h to DATA3.0 and to DATA3.1
	L	H	X	L	DAT0.0 to DAT0.h, DAT1.0 to DAT1.h, DAT2.0 to DAT2.h, DAT3.0 to DAT3.h	DATA0.0 to DATA0.h, DATA1.0 to DATA1.h, DATA2.0 to DATA2.h, DATA3.0 to DATA3.h
	L	H	X	H	DAT0.h to DAT0.0, DAT1.h to DAT1.0, DAT2.h to DAT2.0, DAT3.h to DAT3.0	DATA0.h to DATA0.0, DATA1.h to DATA1.0, DATA2.h to DATA2.0, DATA3.h to DATA3.0
	H	L	X	L	DAT0.1 to DAT0.h, DAT1.1 to DAT1.h, DAT2.1 to DAT2.h, DAT3.1 to DAT3.h	DATA0.1 to DATA0.h, DATA1.1 to DATA1.h, DATA2.1 to DATA2.h, DATA3.1 to DATA3.h
	H	L	X	H	DAT0.h to DAT0.1, DAT1.h to DAT1.1, DAT2.h to DAT2.1, DAT3.h to DAT3.1	DATA0.h to DATA0.1, DATA1.h to DATA1.1, DATA2.h to DATA2.1, DATA3.h to DATA3.1
Command	H	H	X	X	CMD.h, CMD.0, and CMD.1 are Hi Z (isolation mode).	BS.h, BS.0, and BS.1 are Hi Z (isolation mode).
	L	L	H	X	CMD.h to CMD.0 and CMD.1	BS.h to BS.0 and BS.1
	L	L	L	X	CMD.0 and CMD.1 to CMD.h	BS.0 and BS.1 to BS.h
	L	H	H	X	CMD.h to CMD.0	BS.h to BS.0
	L	H	L	X	CMD.0 to CMD.h	BS.0 to BS.h
	H	L	H	X	CMD.h to CMD.1	BS.h to BS.1
	H	L	L	X	CMD.1 to CMD.h	BS.1 to BS.h

† Broadcast mode in which the host writes to or reads from both cards in parallel



SN74AVCA406

MMC, SD CARD, Memory Stick™, SmartMedia, AND xD-Picture Card™ ±15-kV ESD-PROTECTED VOLTAGE-TRANSLATION TRANSCEIVER

SCES615B – OCTOBER 2004 – REVISED DECEMBER 2004

CONFIGURATION 1 FUNCTION TABLE (continued)
(MODE0 = L, MODE1 = L)

SIGNAL	INPUTS				OPERATION	
	$\overline{CS0}$	$\overline{CS1}$	9DIR	(1-4)DIR	MMC/SD	Memory Stick/ Memory Stick PRO
Interrupt request	H	H	X	X	$\overline{DAT1.0}$ and $\overline{DAT1.1}$ to \overline{IRQ} . \overline{IRQ} is an open-drain output.	$\overline{DATA1.0}$ and $\overline{DATA1.1}$ to \overline{IRQ} . \overline{IRQ} is an open-drain output.
	L	H	X	X	$\overline{DAT1.1}$ to \overline{IRQ} . \overline{IRQ} is an open-drain output.	$\overline{DATA1.1}$ to \overline{IRQ} . \overline{IRQ} is an open-drain output.
	H	L	X	X	$\overline{DAT1.0}$ to \overline{IRQ} . \overline{IRQ} is an open-drain output.	$\overline{DATA1.0}$ to \overline{IRQ} . \overline{IRQ} is an open-drain output.
	L	L	X	X	\overline{IRQ} is Hi Z.	\overline{IRQ} is Hi Z.

† Broadcast mode in which the host writes to or reads from both cards in parallel.

SN74AVCA406

MMC, SD CARD, Memory Stick™, SmartMedia, AND xD-Picture Card™

±15-kV ESD-PROTECTED VOLTAGE-TRANSLATION TRANSCEIVER

SCES615B – OCTOBER 2004 – REVISED DECEMBER 2004

configuration 2 – interfacing with SD/SDIO card and using GPIOs for level shifting

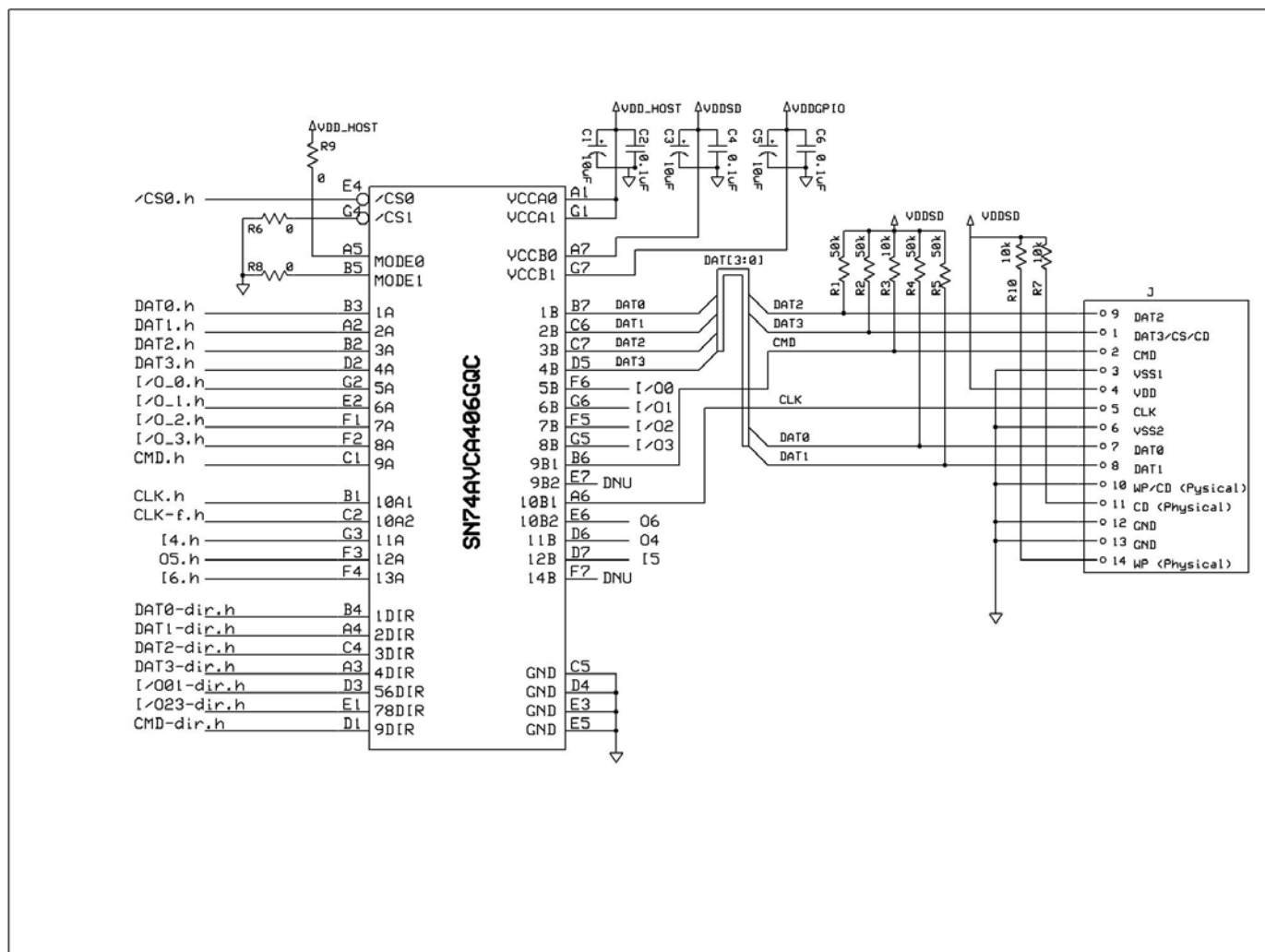

Table 8. SD/SDIO Card Using GPIOs for Level Shifting

PIN NO.	PIN NAME	SIGNAL NAME OR (CONNECTION)	PIN FUNCTION	PIN TYPE
A1	V _{CCA}	V _{CCA}	A-port supply voltage. V _{CCA} powers all A-port I/Os and control inputs.	Power
B1	10A1	CLK.h	Clock signal from host	Input
C1	9A	CMD.h	Command signal connected to host	I/O
D1	9DIR	CMD-dir.h	Direction control for 9A/9B connected to host	Input
E1	78DIR	I/O23-dir.h	Direction control for 7A/7B and 8A/8B. Connected to host. Tie to V _{CCA} if unused.	Input
F1	7A	I/O2.h	General-purpose I/O. Referenced to V _{CCA} . Tie to V _{CCA} or GND if unused.	I/O
G1	V _{CCA}	V _{CCA}	A-port supply voltage. V _{CCA} powers all A-port I/Os and control inputs.	Power
A2	2A	DAT1.h	Data bit 2 connected to host. Referenced to V _{CCA} .	I/O
B2	3A	DAT2.h	Data bit 3 connected to host. Referenced to V _{CCA} .	I/O
C2	10A2	CLK-f.h	Clock feedback to host for resynchronizing data. Used in OMAP processors. Optional on other processors. Leave unconnected if not used.	Output
D2	4A	DAT3.h	Data bit 4 connected to host. Referenced to V _{CCA} .	I/O
E2	6A	I/O1.h	General-purpose I/O. Referenced to V _{CCA} . Tie to V _{CCA} or GND if unused.	I/O
F2	8A	I/O3.h	General-purpose I/O. Referenced to V _{CCA} . Tie to V _{CCA} or GND if unused.	I/O
G2	5A	I/O0.h	General-purpose I/O. Referenced to V _{CCA} . Tie to V _{CCA} or GND if unused.	I/O
A3	4DIR	DAT3-dir.h	Direction control for 4A/4B	Input
B3	1A	DAT0.h	Data bit 1 connected to host. Referenced to V _{CCA} .	I/O
C3			Depopulated ball	
D3	56DIR	I/O01-dir.h	Direction control for 5A/5B and 6A/6B. Referenced to V _{CCA} . Tie to V _{CCA} if unused.	Input
E3	GND	GND	Ground	
F3	12A	O5.h	General-purpose output connected to host. Referenced to V _{CCA} .	Output
G3	11A	I4.h	General-purpose input connected to host. Referenced to V _{CCA} .	Input
A4	2DIR	DAT1-dir.h	Direction control for 2A/2B connected to host	Input
B4	1DIR	DAT0-dir.h	Direction control for 1A/1B connected to host	Input
C4	3DIR	DAT2-dir.h	Direction control for 3A/3B connected to host	Input
D4	GND	GND	Ground	
E4	$\overline{\text{CS0}}$	$\overline{\text{CS0}}$.h	Card select from host. Active low. When $\overline{\text{CS0}}$ = high, 1A, 2A, 3A, 4A, 1B, 2B, 3B, 4B, 9A, 9B, and 10A2 are placed in Hi Z and 10B1 is low.	Input
F4	13A	I6.h	General-purpose input connected to host. Referenced to V _{CCA} .	Input
G4	$\overline{\text{CS1}}$	(tie-low)	Card select. Tie to GND for proper operation.	Input
A5	MODE1	(tie-low)	MODE1, MODE0 determine mode of operation (see Table 1). Tie MODE0 to V _{CCA} . Tie MODE1 to GND.	Input
B5	MODE0	(tie-high)		Input
C5	GND	GND	Ground	
D5	4B	DAT3	Data bit 4 connected to card. Referenced to V _{CCB0} .	I/O
E5	GND	GND	Ground	
F5	7B	I/O2	General-purpose I/O. Referenced to V _{CCB1} .	I/O
G5	8B	I/O3	General-purpose I/O. Referenced to V _{CCB1} .	I/O
A6	10B1	CLK	Clock signal connected to card	Output
B6	9B1	CMD	Command signal connected to card	Output
C6	2B	DAT1	Data bit 2 connected to card. Referenced to V _{CCB0} .	I/O

SN74AVCA406

MMC, SD CARD, Memory Stick™, SmartMedia, AND xD-Picture Card™
±15-kV ESD-PROTECTED VOLTAGE-TRANSLATION TRANSCEIVER
SCES615B – OCTOBER 2004 – REVISED DECEMBER 2004

Table 8. SD/SDIO Card Using GPIOs for Level Shifting (Continued)

PIN NO.	PIN NAME	SIGNAL NAME OR (CONNECTION)	PIN FUNCTION	PIN TYPE
D6	11B	O4	General-purpose output. Referenced to V _{CCB1} .	Output
E6	10B2	O6	General-purpose output. Referenced to V _{CCB1} .	Output
F6	5B	I/O0	General-purpose I/O. Referenced to V _{CCB1} .	I/O
G6	6B	I/O1	General-purpose I/O. Referenced to V _{CCB1} .	I/O
A7	V _{CCB0}	V _{CCB0}	B-port supply voltage. V _{CCB0} powers 1B, 2B, 3B, 4B, 9B1, and 10B1.	Power
B7	1B	DAT0	Data bit 1 connected to card. Referenced to V _{CCB0} .	I/O
C7	3B	DAT2	Data bit 3 connected to card. Referenced to V _{CCB0} .	I/O
D7	12B	I5	General-purpose Input. Referenced to V _{CCB1} .	Input
E7	9B2	DNU	I/O pin not used in this mode. Leave unconnected.	I/O
F7	14B	DNU	Open-drain output not used in this mode. Leave unconnected.	Output
G7	V _{CCB1}	V _{CCB1}	B-port supply voltage. V _{CCB1} powers 5B, 6B, 7B, 8B, 9B2, 10B2, 11B, 12B, and 14B.	Power

SN74AVCA406

MMC, SD CARD, Memory Stick™, SmartMedia, AND xD-Picture Card™ ±15-kV ESD-PROTECTED VOLTAGE-TRANSLATION TRANSCEIVER

SCES615B – OCTOBER 2004 – REVISED DECEMBER 2004

CONFIGURATION 2 FUNCTION TABLE
(MODE0 = H, MODE1 = L)

SIGNAL	INPUTS						OPERATION	
	$\overline{CS0}$	$\overline{CS1}$	9DIR	(1-4)DIR	56DIR	78DIR	MMC/SD	Memory Stick/ Memory Stick PRO
Clock	H	H	X	X	X	X	CLK forced low, CLK-f.h forced Hi Z	SCLK forced low, SCLK-f.h forced Hi Z
	L	L	X	X	X	X	CLK.h to CLK, CLK to CLK-f.h	SCLK.h to SCLK, SCLK to SCLK-f.h
Data	H	H	X	X	X	X	All data I/Os are Hi Z (isolation mode).	All data I/Os are Hi Z (isolation mode).
	L	L	X	L	X	X	DAT0 to DAT0.h, DAT1 to DAT1.h, DAT2 to DAT2.h, DAT3 to DAT3.h	DATA0 to DATA0.h, DATA1 to DATA1.h, DATA2 to DATA2.h, DATA3 to DATA3.h
	L	L	X	H	X	X	DAT0.h to DAT0, DAT1.h to DAT1, DAT2.h to DAT2, DAT3.h to DAT3	DATA0.h to DATA0, DATA1.h to DATA1, DATA2.h to DATA2, DATA3.h to DATA3
Command	H	H	X	X	X	X	CMD.h and CMD are Hi Z (isolation mode).	BS.h and BS are Hi Z (isolation mode).
	L	L	L	X	X	X	CMD to CMD.h	BS to BS.h
	L	L	H	X	X	X	CMD.h to CMD	BS.h to BS
GPIO	H	H	X	X	X	X	All GPIOs are Hi Z.	All GPIOs are Hi Z.
	L	L	X	X	X	X	I4 to O4, I5 to O5, I6 to O6	I4 to O4, I5 to O5, I6 to O6
	L	L	X	X	L	X	I/O0 to I/O0.h, I/O1 to I/O1.h	I/O0 to I/O0.h, I/O1 to I/O1.h
	L	L	X	X	H	X	I/O0.h to I/O0, I/O1.h to I/O1	I/O0.h to I/O0, I/O1.h to I/O1
	L	L	X	X	X	L	I/O2 to I/O2.h, I/O3 to I/O3.h	I/O2 to I/O2.h, I/O3 to I/O3.h
	L	L	X	X	X	H	I/O2.h to I/O2, I/O3.h to I/O3	I/O2.h to I/O2, I/O3.h to I/O3

SN74AVCA406
MMC, SD CARD, Memory Stick™, SmartMedia, AND xD-Picture Card™
±15-kV ESD-PROTECTED VOLTAGE-TRANSLATION TRANSCEIVER

SCES615B – OCTOBER 2004 – REVISED DECEMBER 2004

configuration 3 – interfacing with 8-bit MMC

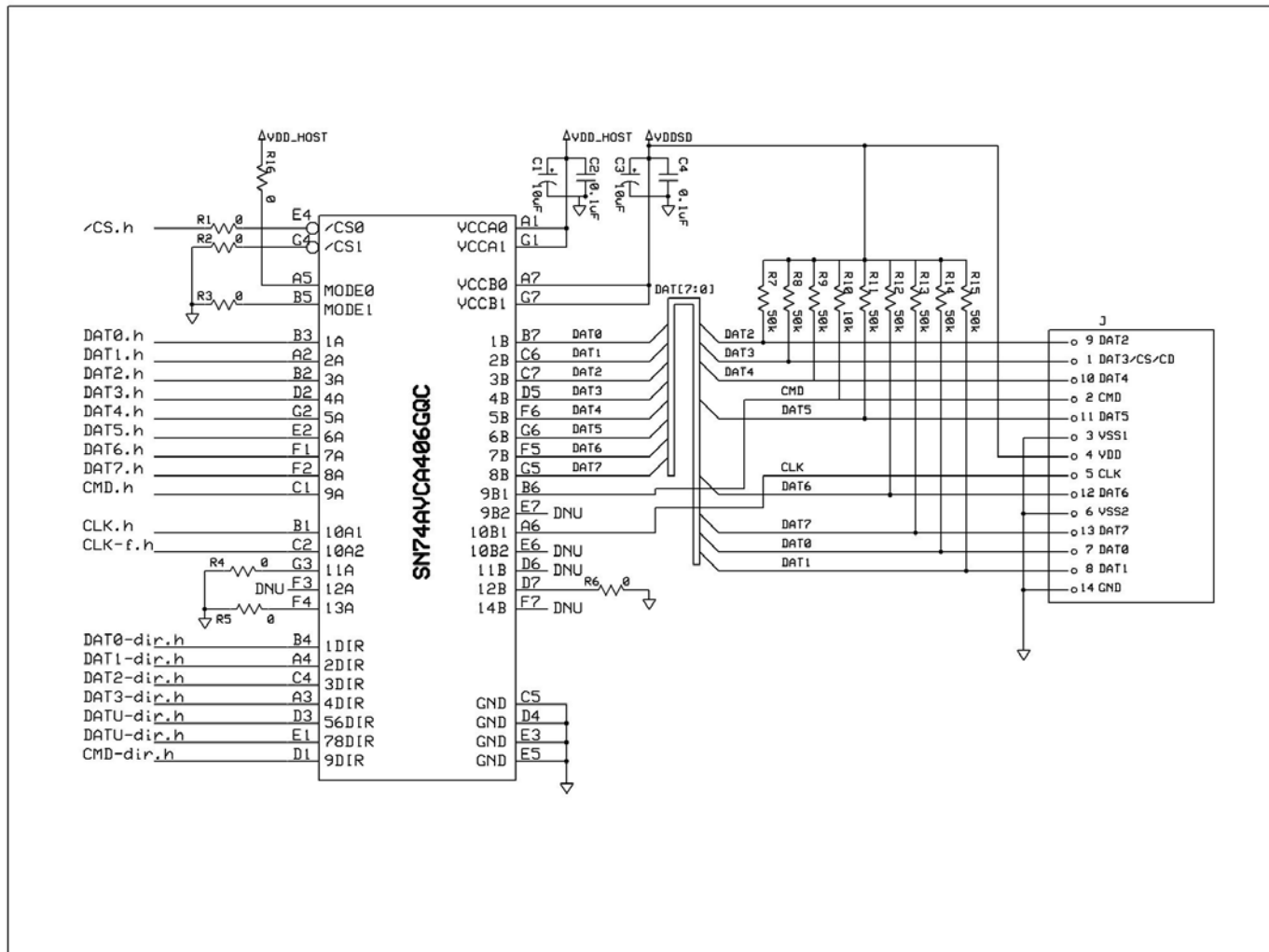

SN74AVCA406
MMC, SD CARD, Memory Stick™, SmartMedia, AND xD-Picture Card™
±15-kV ESD-PROTECTED VOLTAGE-TRANSLATION TRANSCEIVER

SCES615B – OCTOBER 2004 – REVISED DECEMBER 2004

Table 9. 8-Bit MMC

PIN NO.	PIN NAME	SIGNAL NAME OR (CONNECTION)	PIN FUNCTION	PIN TYPE
A1	V _{CCA}	V _{CCA}	A-port supply voltage. V _{CCA} powers all A-port I/Os and control inputs.	Power
B1	10A1	CLK.h	Clock signal from host	Input
C1	9A	CMD.h	Command signal connected to host	I/O
D1	9DIR	CMD-dir.h	Direction control for 9A/9B connected to host	Input
E1	78DIR	DATU-dir.h	Direction control for 7A/7B and 8A/8B. Connected to host.	Input
F1	7A	DAT6.h	General-purpose I/O. Referenced to V _{CCA} .	I/O
G1	V _{CCA}	V _{CCA}	A-port supply voltage. V _{CCA} powers all A-port I/Os and control inputs.	Power
A2	2A	DAT1.h	Data bit 2 connected to host. Referenced to V _{CCA} .	I/O
B2	3A	DAT2.h	Data bit 3 connected to host. Referenced to V _{CCA} .	I/O
C2	10A2	CLK-f.h	Clock feedback to host for resynchronizing data. Used in OMAP processors. Optional on other processors. Leave unconnected if not used.	Output
D2	4A	DAT3.h	Data bit 4 connected to host. Referenced to V _{CCA} .	I/O
E2	6A	DAT5.h	General-purpose I/O. Referenced to V _{CCA} .	I/O
F2	8A	DAT7.h	General-purpose I/O. Referenced to V _{CCA} .	I/O
G2	5A	DAT4.h	General-purpose I/O. Referenced to V _{CCA} .	I/O
A3	4DIR	DAT3-dir.h	Direction control for 4A/4B	Input
B3	1A	DAT0.h	Data bit 1 connected to host. Referenced to V _{CCA} .	I/O
C3	Depopulated ball			
D3	56DIR	DATU-dir.h	Direction control for 5A/5B and 6A/6B. Referenced to V _{CCA} .	Input
E3	GND	GND	Ground	
F3	12A	DNU	Output pin not used in this mode. Do not use. Leave unconnected.	Output
G3	11A	(tie-low)	Input pin not used in this mode. Tie to GND.	Input
A4	2DIR	DAT1-dir.h	Direction control for 2A/2B connected to host	Input
B4	1DIR	DAT0-dir.h	Direction control for 1A/1B connected to host	Input
C4	3DIR	DAT2-dir.h	Direction control for 3A/3B connected to host	Input
D4	GND	GND	Ground	
E4	$\overline{\text{CS0}}$	$\overline{\text{CS0}}$.h	Card select from host. Active low. When $\overline{\text{CS0}}$ = high, 1A, 2A, 3A, 4A, 1B, 2B, 3B, 4B, and 9B1 are placed in Hi Z, and 10B1 is low.	Input
F4	13A	(tie-low)	Input pin not used in this mode. Tie to GND.	Input
G4	$\overline{\text{CS1}}$	(tie-low)	Card select signal. For proper operation, tie to GND.	Input
A5	MODE1	(tie-low)	MODE1, MODE0 determine mode of operation (see Table 1). Tie MODE0 to V _{CCA} . Tie MODE1 to GND.	Input
B5	MODE0	(tie-high)		Input
C5	GND	GND	Ground	
D5	4B	DAT3	Data bit 4 connected to card. Referenced to V _{CCB} .	I/O
E5	GND	GND	Ground	
F5	7B	DAT6	Data bit 6 connected to card. Referenced to V _{CCB} .	I/O
G5	8B	DAT7	Data bit 7 connected to card. Referenced to V _{CCB} .	I/O
A6	10B1	CLK	Clock signal connected to card	Output
B6	9B1	CMD	Command signal connected to card	Output

SN74AVCA406

MMC, SD CARD, Memory Stick™, SmartMedia, AND xD-Picture Card™
±15-kV ESD-PROTECTED VOLTAGE-TRANSLATION TRANSCEIVER

SCES615B – OCTOBER 2004 – REVISED DECEMBER 2004

Table 9. 8-Bit MMC (Continued)

PIN NO.	PIN NAME	SIGNAL NAME OR (CONNECTION)	PIN FUNCTION	PIN TYPE
C6	2B	DAT1	Data bit 2 connected to card. Referenced to V_{CCB0} .	I/O
D6	11B	DNU	Output pin not used in this mode. Leave unconnected.	Output
E6	10B2	DNU	Output pin not used in this mode. Leave unconnected.	Output
F6	5B	DAT4	Data bit 4 connected to card. Referenced to V_{CCB} .	I/O
G6	6B	DAT5	Data bit 5 connected to card. Referenced to V_{CCB} .	I/O
A7	V_{CCB0}	V_{CCB0}	B-port supply voltage. V_{CCB0} powers 1B, 2B, 3B, 4B, 9B1, and 10B1.	Power
B7	1B	DAT0	Data bit 1 connected to card. Referenced to V_{CCB0} .	I/O
C7	3B	DAT2	Data bit 3 connected to card. Referenced to V_{CCB0} .	I/O
D7	12B	(tie-low)	Input pin not used in this mode. Tie to GND.	Input
E7	9B2	DNU	I/O pin not used in this mode. Leave unconnected.	I/O
F7	14B	DNU	Open-drain output not used in this mode. Leave unconnected.	Output
G7	V_{CCB1}	V_{CCB1}	B-port supply voltage. V_{CCB1} powers 5B, 6B, 7B, 8B, 9B2, 10B2, 11B, 12B and 14B. Not used in this mode. Tie to GND.	Power

SN74AVCA406

MMC, SD CARD, Memory Stick™, SmartMedia, AND xD-Picture Card™
±15-kV ESD-PROTECTED VOLTAGE-TRANSLATION TRANSCEIVER

SCES615B – OCTOBER 2004 – REVISED DECEMBER 2004

CONFIGURATION 3 FUNCTION TABLE
(MODE0 = H, MODE1 = L, 8-bit MMC)

SIGNAL	INPUTS						OPERATION
	$\overline{CS0}$	$\overline{CS1}$	9DIR	(1-4)DIR	56DIR	78DIR	
Clock	L	X	X	X	X	X	CLK.h to CLK, CLK to CLK-f.h
Data	H	X	X	X	X	X	DAT0.h, DAT1.h, DAT2.h, DAT3.h, DAT0, DAT1, DAT2, and DAT3 are Hi Z.
	X	H	X	X	X	X	DAT4.h, DAT5.h, DAT6.h, DAT7.h, DAT4, DAT5, DAT6, and DAT7 are Hi Z.
	L	L	X	L	L	L	DAT0 to DAT0.h, DAT1 to DAT1.h, DAT2 to DAT2.h, DAT3 to DAT3.h, DAT4 to DAT4.h, DAT5 to DAT5.h, DAT6 to DAT6.h, DAT7 to DAT7.h
	L	L	X	H	H	H	DAT0.h to DAT0, DAT1.h to DAT1, DAT2.h to DAT2, DAT3.h to DAT3, DAT4.h to DAT4, DAT5.h to DAT5, DAT6.h to DAT6, DAT7.h to DAT7
Command	H	X	X	X	X	X	CMD.h and CMD are Hi Z (isolation mode).
	L	X	L	X	X	X	CMD to CMD.h
	L	X	H	X	X	X	CMD.h to CMD

configuration 4 – interfacing with SmartMedia or xD-Picture Card

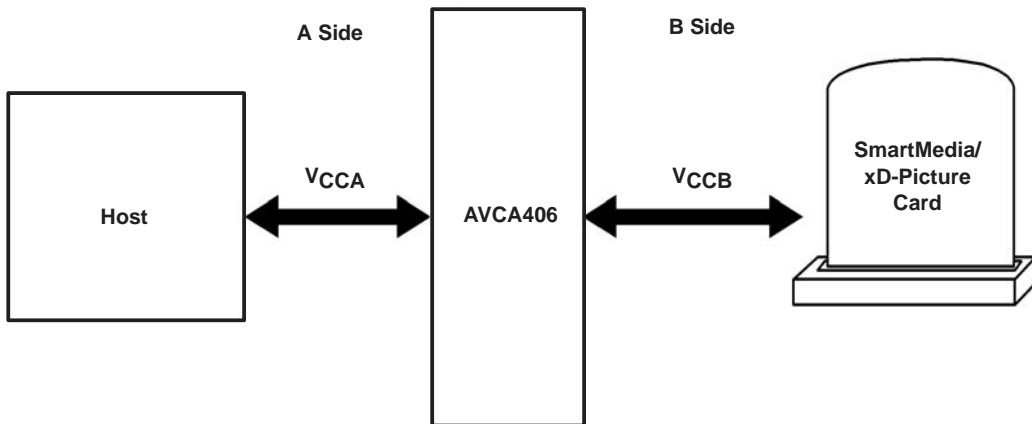

Table 10. SmartMedia or xD-Picture Card

PIN NO.	PIN NAME	SIGNAL NAME OR (CONNECTION)	PIN FUNCTION	PIN TYPE
A1	V _{CCA}	V _{CCA}	A-port supply voltage. V _{CCA} powers all A-port I/Os and control inputs.	Power
B1	10A1	/RE.h	Read enable connected to host	Input
C1	9A	CLE.h	Command latch enable connected to host	Input
D1	9DIR	(tie-low)	Input pin not used in this mode. Tie to GND.	Input
E1	78DIR	I/O-dir.h	Data direction control from host	Input
F1	7A	I/O7.h	Data I/O 7 connected to host. Referenced to V _{CCA} .	I/O
G1	V _{CCA}	V _{CCA}	A-port supply voltage. V _{CCA} powers all A-port I/Os and control inputs.	Power
A2	2A	I/O2.h	Data I/O 2 connected to host. Referenced to V _{CCA} .	I/O
B2	3A	I/O3.h	Data I/O 3 connected to host. Referenced to V _{CCA} .	I/O
C2	10A2	/RE-f.h	Read enable feedback to host. Used with OMAP processors. Use with other processors is optional. Leave unconnected if not used.	Output
D2	4A	I/O4.h	Data I/O 4 connected to host. Referenced to V _{CCA} .	I/O
E2	6A	I/O6.h	Data I/O 6 connected to host. Referenced to V _{CCA} .	I/O
F2	8A	I/O8.h	Data I/O 8 connected to host. Referenced to V _{CCA} .	I/O
G2	5A	I/O5.h	Data I/O 5 connected to host. Referenced to V _{CCA} .	I/O
A3	4DIR	I/O-dir.h	Data direction control connected to host	Input
B3	1A	I/O1.h	Data I/O 1 connected to host. Referenced to V _{CCA} .	I/O
C3	Depopulated ball			
D3	56DIR	I/O-dir.h	Data direction control connected to host	Input
E3	GND	GND	Ground	
F3	12A	R/B.h	Read/busy connected to host. Open-drain output.	Output
G3	11A	/WP.h	Write protect connected to host	Input
A4	2DIR	I/O-dir.h	Data direction control connected to host	Input
B4	1DIR	I/O-dir.h	Data direction control connected to host	Input
C4	3DIR	I/O-dir.h	Data direction control connected to host	Input

SN74AVCA406
MMC, SD CARD, Memory Stick™, SmartMedia, AND xD-Picture Card™
±15-kV ESD-PROTECTED VOLTAGE-TRANSLATION TRANSCEIVER

SCES615B – OCTOBER 2004 – REVISED DECEMBER 2004

Table 10. SmartMedia or xD-Picture Card (Continued)

PIN NO.	PIN NAME	SIGNAL NAME OR (CONNECTION)	PIN FUNCTION	PIN TYPE
D4	GND	GND	Ground	
E4	$\overline{\text{CS0}}$	/CE.h	Chip enable from host	Input
F4	13A	/WE.h	Write enable from host	Input
G4	$\overline{\text{CS1}}$	ALE.h	Address latch enable connected to host	Input
A5	MODE1	(tie-high)	MODE1, MODE0 determine mode of operation (see Table 1). Tie to V _{CCA} .	Input
B5	MODE0	(tie-high)		Input
C5	GND	GND	Ground	
D5	4B	I/O4	Data I/O 4 connected to card. Referenced to V _{CCB} .	I/O
E5	GND	GND	Ground	
F5	7B	I/O7	Data I/O 7 connected to card. Referenced to V _{CCB} .	I/O
G5	8B	I/O8	Data I/O 8 connected to card. Referenced to V _{CCB} .	I/O
A6	10B1	/RE	Read enable connected to card	Output
B6	9B1	CLE	Command latch enable connected to card	Output
C6	2B	I/O2	Data I/O 2 connected to card. Referenced to V _{CCB} .	I/O
D6	11B	/WP	Write protect connected to card	Output
E6	10B2	/WE	Write enable connected to card	Output
F6	5B	I/O5	Data I/O 5 connected to card. Referenced to V _{CCB} .	I/O
G6	6B	I/O6	Data I/O 6 connected to card. Referenced to V _{CCB} .	I/O
A7	V _{CCB0}	V _{CCB}	B-port supply voltage. V _{CCB0} powers 1B, 2B, 3B, 4B, 9B1, and 10B1.	Power
B7	1B	I/O1	Data I/O 1 connected to card. Referenced to V _{CCB} .	I/O
C7	3B	I/O3	Data I/O 3 connected to card. Referenced to V _{CCB} .	I/O
D7	12B	R/B	Read/busy connected to card	Input
E7	9B2	ALE	Address latch enable connected to host	I/O
F7	14B	/CE	Chip enable connected to card	Output
G7	V _{CCB1}	V _{CCB}	B-port supply voltage. V _{CCB1} powers 5B, 6B, 7B, 8B, 9B2, 10B2, 11B, 12B, and 14B.	Power

SN74AVCA406

MMC, SD CARD, Memory Stick™, SmartMedia, AND xD-Picture Card™
±15-kV ESD-PROTECTED VOLTAGE-TRANSLATION TRANSCEIVER
SCES615B – OCTOBER 2004 – REVISED DECEMBER 2004

CONFIGURATION 4 FUNCTION TABLE
(MODE0 = H, MODE1 = H, 8-bit SmartMedia/xD-Picture Card)

SIGNAL	INPUTS						OPERATION
	$\overline{CS0}$	$\overline{CS1}$	9DIR	(1-4)DIR	56DIR	78DIR	
Clock	X	X	X	X	X	X	$\overline{WE}.h$ to \overline{WE}
	L	X	X	X	X	X	$\overline{RE}.h$ to \overline{RE} , \overline{RE} to $\overline{RE}.f.h$
Data	H	X	X	X	X	X	All data I/Os are Hi Z (isolation mode).
	L	X	X	L	L	L	I/O(1-8) to I/O(1-8).h
	L	X	X	H	H	H	I/O(1-8).h to I/O(1-8)
Command	X	X	X	X	X	X	CLE.h to CLE, ALE.h to ALE
Interrupt request	X	X	X	X	X	X	$\overline{CE}.h$ to \overline{CE}
Others	X	X	X	X	X	X	$\overline{WP}.h$ to \overline{WP} , R/B to R/B.h (R/B.h is an open-drain output)

SN74AVCA406

MMC, SD CARD, Memory Stick™, SmartMedia, AND xD-Picture Card™ ±15-kV ESD-PROTECTED VOLTAGE-TRANSLATION TRANSCEIVER

SCES615B – OCTOBER 2004 – REVISED DECEMBER 2004

logic diagrams (positive logic)

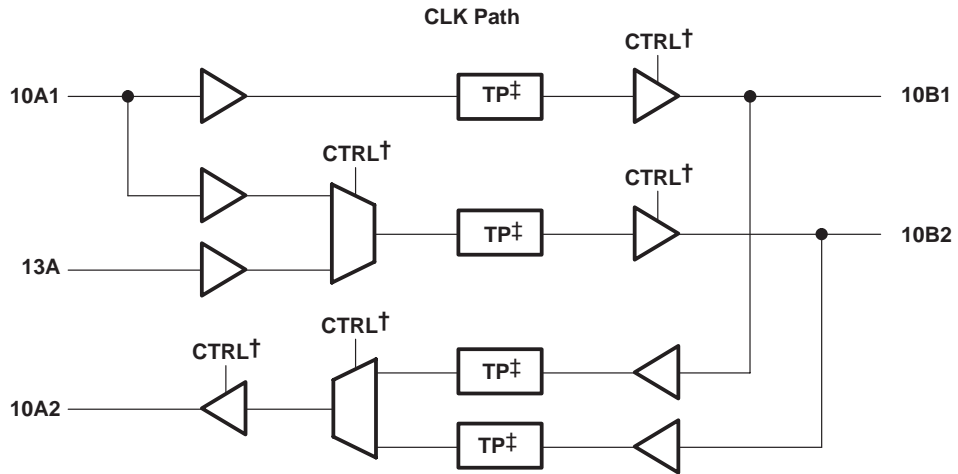

† CTRL represents a decoded MODE0, MODE1, $\overline{CS0}$, and $\overline{CS1}$ state.

‡ Translation point

logic diagrams (positive logic) (continued)

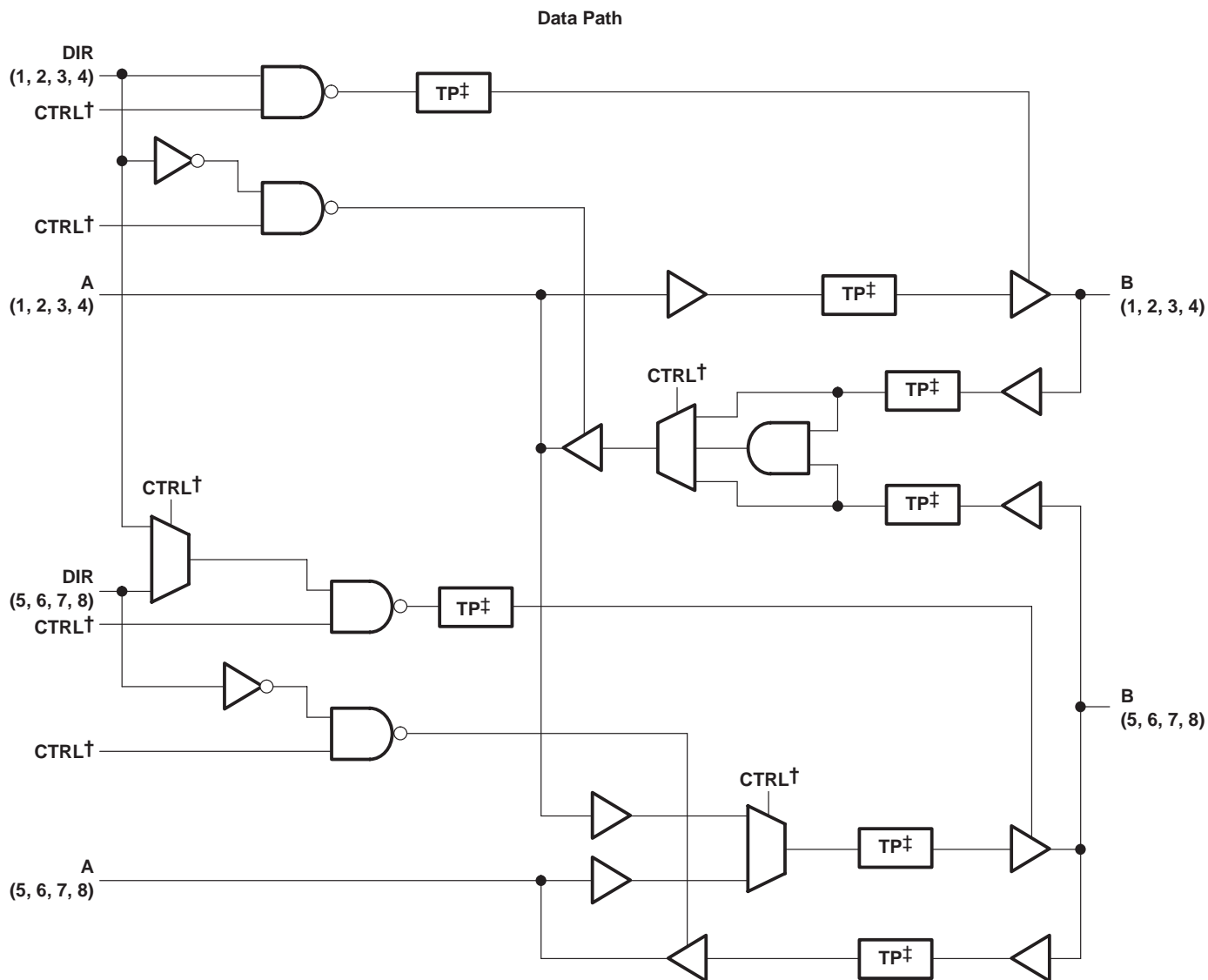

† CTRL represents a decoded MODE0, MODE1, $\overline{CS0}$, and $\overline{CS1}$ state.

‡ Translation point

SN74AVCA406

MMC, SD CARD, Memory Stick™, SmartMedia, AND xD-Picture Card™ ±15-kV ESD-PROTECTED VOLTAGE-TRANSLATION TRANSCEIVER

SCES615B – OCTOBER 2004 – REVISED DECEMBER 2004

logic diagrams (positive logic) (continued)

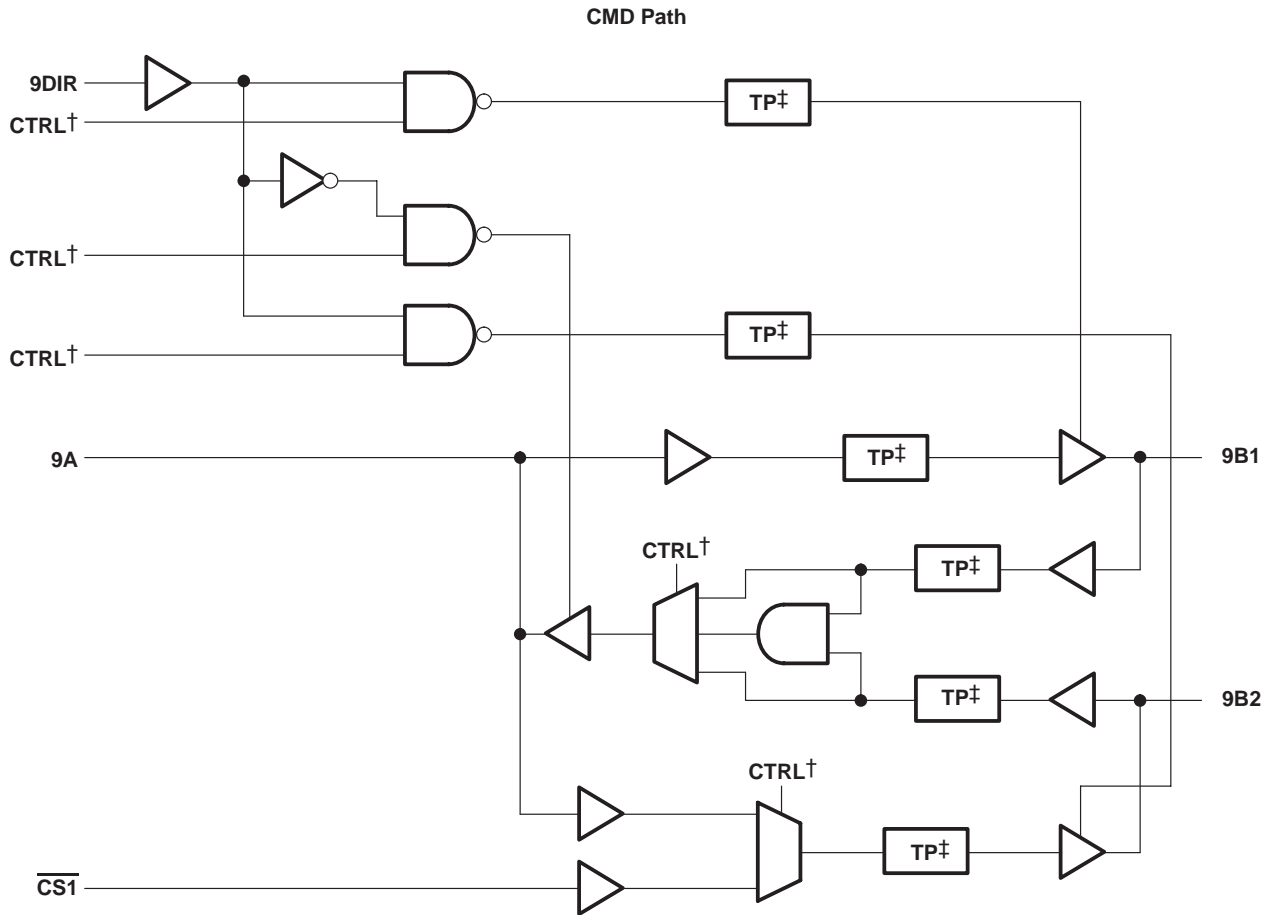

† CTRL represents a decoded MODE0, MODE1, $\overline{CS0}$, and $\overline{CS1}$ state.

‡ Translation point

\overline{WP} and R/B Paths

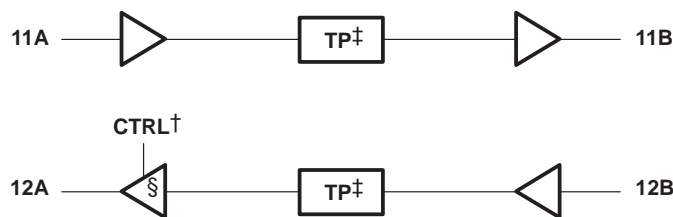

† CTRL represents a decoded MODE0, MODE1, $\overline{CS0}$, and $\overline{CS1}$ state.

‡ Translation point

§ 12A is open drain in NAND (XD) mode and push-pull in other modes.

logic diagrams (positive logic) (continued)

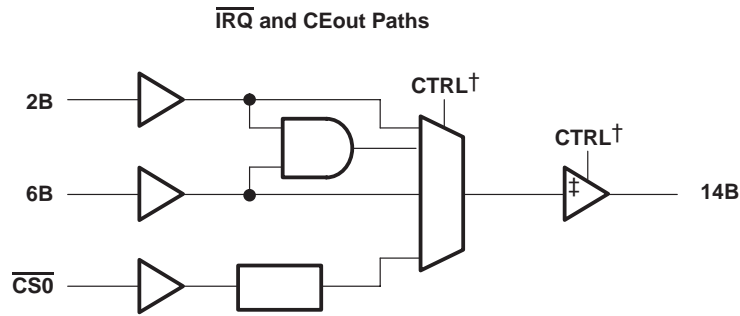

† CTRL represents a decoded MODE0, MODE1, $\overline{\text{CS0}}$, and $\overline{\text{CS1}}$ state.

‡ Push-pull in NAND flash (XD) mode and open drain in other modes

SN74AVCA406

MMC, SD CARD, Memory Stick™, SmartMedia, AND xD-Picture Card™

±15-kV ESD-PROTECTED VOLTAGE-TRANSLATION TRANSCEIVER

SCES615B – OCTOBER 2004 – REVISED DECEMBER 2004

absolute maximum ratings over operating free-air temperature range (unless otherwise noted)†

Supply voltage range, V_{CCA} and V_{CCB}	–0.5 V to 4.6 V
Input voltage range, V_I (see Note 1): I/O ports (A port)	–0.5 V to $V_{CCA} + 0.5$ V
I/O ports (B port)	–0.5 V to $V_{CCB} + 0.5$ V
Control inputs	–0.5 V to 4.6 V
Voltage range applied to any output in the high-impedance or power-off state, V_O	
(see Note 1): A port	–0.5 V to $V_{CCA} + 0.5$ V
B port	–0.5 V to $V_{CCB} + 0.5$ V
Voltage range applied to any output in the high or low state, V_O	
(see Notes 1 and 2): A port	–0.5 V to $V_{CCA} + 0.5$ V
B port	–0.5 V to $V_{CCB} + 0.5$ V
Input clamp current, I_{IK} ($V_I < 0$)	–50 mA
Output clamp current, I_{OK} ($V_O < 0$)	–50 mA
Continuous output current, I_O	±50 mA
Continuous current through V_{CCA} , V_{CCB} , or GND	±100 mA
Package thermal impedance, θ_{JA} (see Note 3)	34°C/W
Storage temperature range, T_{stg}	–65°C to 150°C

† Stresses beyond those listed under “absolute maximum ratings” may cause permanent damage to the device. These are stress ratings only, and functional operation of the device at these or any other conditions beyond those indicated under “recommended operating conditions” is not implied. Exposure to absolute-maximum-rated conditions for extended periods may affect device reliability.

- NOTES:
1. The input voltage and output negative-voltage ratings may be exceeded if the input and output current ratings are observed.
 2. The output positive-voltage rating may be exceeded up to 4.6 V maximum if the output current rating is observed.
 3. The package thermal impedance is calculated in accordance with JESD 51-7.

SN74AVCA406
MMC, SD CARD, Memory Stick™, SmartMedia, AND xD-Picture Card™
±15-kV ESD-PROTECTED VOLTAGE-TRANSLATION TRANSCEIVER
SCES615B – OCTOBER 2004 – REVISED DECEMBER 2004

recommended operating conditions (see Notes 4 through 7)

		V _{CCI}	V _{CCO}	MIN	MAX	UNIT
V _{CCA}	Supply voltage			1.4	V _{CCB}	V
V _{CCB}	Supply voltage			1.4	3.6	V
V _{IH}	High-level input voltage	All inputs†	1.4 V to 1.95 V		V _{CCI} × 0.65	V
			1.95 V to 2.7 V		1.7	
			2.7 V to 3.6 V		2	
V _{IL}	Low-level input voltage	All inputs†	1.4 V to 1.95 V		V _{CCI} × 0.35	V
			1.95 V to 2.7 V		0.7	
			2.7 V to 3.6 V		0.8	
V _I	Input voltage			0	V _{CCI}	V
V _O	Output voltage	Active state		0	V _{CCO}	V
		3-state		0	V _{CCO}	
I _{OH}	High-level output current (A port)		1.4 V to 1.6 V		-1	mA
			1.65 V to 1.95 V		-2	
			2.3 V to 2.7 V		-4	
			3 V to 3.6 V		-8	
I _{OL}	Low-level output current (A port)		1.4 V to 1.6 V		1	mA
			1.65 V to 1.95 V		2	
			2.3 V to 2.7 V		4	
			3 V to 3.6 V		8	
I _{OH}	High-level output current (B port)		1.4 V to 1.6 V		-2	mA
			1.65 V to 1.95 V		-4	
			2.3 V to 2.7 V		-8	
			3 V to 3.6 V		-16	
I _{OL}	Low-level output current (B port)		1.4 V to 1.6 V		2	mA
			1.65 V to 1.95 V		4	
			2.3 V to 2.7 V		8	
			3 V to 3.6 V		16	
Δt/Δv	Input transition rise or fall rate				5	ns/V
T _A	Operating free-air temperature			-40	85	°C

† All A-port I/Os and control inputs are powered by V_{CCA}.

1B, 2B, 3B, 4B, 9B1, and 10B1 are powered by V_{CCB0}. 5B, 6B, 7B, 8B, 9B2, 10B2, 11B, 12B, and 14B are powered by V_{CCB1}.

NOTES: 4. V_{CCI} is the V_{CC} associated with the data input port.

5. V_{CCO} is the V_{CC} associated with the output port.

6. V_{CCB} must be greater than or equal to V_{CCA}, except when V_{CCB} = 0 V.

7. All unused data inputs of the device must be held at V_{CCI} or GND to ensure proper device operation. Refer to the TI application report, *Implications of Slow or Floating CMOS Inputs*, literature number SCBA004.



SN74AVCA406
MMC, SD CARD, Memory Stick™, SmartMedia, AND xD-Picture Card™
±15-kV ESD-PROTECTED VOLTAGE-TRANSLATION TRANSCEIVER

SCES615B – OCTOBER 2004 – REVISED DECEMBER 2004

electrical characteristics over recommended operating free-air temperature range (unless otherwise noted) (see Notes 8 and 9)

PARAMETER		TEST CONDITIONS		V _{CCA}	V _{CCB}	MIN	TYP†	MAX	UNIT
V _{OH} (A port)		I _{OH} = -100 μA	V _I = V _{IH}	1.4 V to 3.6 V	1.4 V to 3.6 V	V _{CCO} - 0.2 V			V
				1.4 V	1.4 V	1.05			
				1.65 V	1.65 V	1.2			
				2.3 V	2.3 V	1.75			
				3 V	3 V	2.3			
V _{OL} (A port)		I _{OL} = 100 μA	V _I = V _{IL}	1.4 V to 3.6 V	1.4 V to 3.6 V			0.2	V
				1.4 V	1.4 V			0.35	
				1.65 V	1.65 V			0.45	
				2.3 V	2.3 V			0.55	
				3 V	3 V			0.7	
		I _{OL} = 2 mA	Open-drain output (12A)	3 V	3 V			0.45	
V _{OH} (B port)		I _{OH} = -100 μA	V _I = V _{IH}	1.4 V to 3.6 V	1.4 V to 3.6 V	V _{CCO} - 0.2 V			V
				1.4 V	1.4 V	1.05			
				1.65 V	1.65 V	1.2			
				2.3 V	2.3 V	1.75			
				3 V	3 V	2.3			
V _{OL} (B port)		I _{OL} = 100 μA	V _I = V _{IL}	1.4 V to 3.6 V	1.4 V to 3.6 V			0.2	V
				1.4 V	1.4 V			0.35	
				1.65 V	1.65 V			0.45	
				2.3 V	2.3 V			0.55	
				3 V	3 V			0.7	
		I _{OL} = 2 mA	Open-drain output (14B)	3 V	3 V			0.45	
I _I	Control inputs	V _I = V _{CCA} or GND		1.4 V to 3.6 V	3.6 V			±2.5	μA
I _{off}	14B	V _O = V _{CCA}		0 to 3.6 V	0 V			±10	μA
I _{OZ} ‡	A or B ports	V _O = V _{CCO} or GND, V _I = V _{IH} or V _{IL}	See function table for input states when outputs are Hi Z	3.6 V	3.6 V			±10	μA
	A port				0 V			±10	
I _{CCA}		V _I = V _{CC1} or GND, I _O = 0		1.6 V	1.6 V			4.5	μA
				1.95 V	1.95 V			5	
				1.95 V	0 V			5	
				2.7 V	2.7 V			5.5	
				3.6 V	0 V			10	
				3.6 V	3.6 V			10	
I _{CCB}		V _I = V _{CC1} or GND, I _O = 0		1.6 V	1.6 V			6.5	μA
				1.95 V	1.95 V			7	
				1.95 V	0 V			0.5	
				2.7 V	2.7 V			7.5	
				3.6 V	0 V			1	
				3.6 V	3.6 V			10	

 † All typical values are at T_A = 25°C.

 ‡ For I/O ports, the parameter I_{OZ} includes the input leakage current.

 NOTES: 8. V_{CCO} is the V_{CC} associated with the output port.

 9. V_{CC1} is the V_{CC} associated with the data input port.

SN74AVCA406
MMC, SD CARD, Memory Stick™, SmartMedia, AND xD-Picture Card™
±15-kV ESD-PROTECTED VOLTAGE-TRANSLATION TRANSCEIVER
SCES615B – OCTOBER 2004 – REVISED DECEMBER 2004

electrical characteristics over recommended operating free-air temperature range (unless otherwise noted) (see Notes 8 and 9) (continued)

PARAMETER		TEST CONDITIONS	V _{CCA}	V _{CCB}	MIN	TYP†	MAX	UNIT
C _i	Control inputs	V _I = V _{CCA} or GND	1.8 V	3 V	3.5		4	pF
	Clock input				4			
C _O	14B	V _O = V _{CCB} or GND	1.8 V	3 V	17.5		pF	
C _{io}	A port	V _O = V _{CCA} or GND	1.8 V	3 V	4.5		11	pF
	B port	V _O = V _{CCB} or GND			11			

† All typical values are at T_A = 25°C.

‡ For I/O ports, the parameter I_{OZ} includes the input leakage current.

NOTES: 8. V_{CCO} is the V_{CC} associated with the output port.

9. V_{CCJ} is the V_{CC} associated with the data input port.

output slew rates over recommended operating free-air temperature range (unless otherwise noted)§

PARAMETER	FROM	TO	V _{CCA} = 1.8 V ± 0.15 V, V _{CCB} = 3 V ± 0.3 V		UNIT
			MIN	MAX	
t _r	20%	80%	3¶		ns
t _f	80%	20%	3¶		ns

§ Values are characterized but not production tested.

¶ Using C_L = 15 pF on the B side and C_L = 7 pF on the A side. See derating curves for other load conditions.

SN74AVCA406

MMC, SD CARD, Memory Stick™, SmartMedia, AND xD-Picture Card™

±15-kV ESD-PROTECTED VOLTAGE-TRANSLATION TRANSCEIVER

SCES615B – OCTOBER 2004 – REVISED DECEMBER 2004

switching characteristics over recommended operating free-air temperature range,
 $V_{CCA} = 1.5 \text{ V} \pm 0.1 \text{ V}$ (see Figure 5)

PARAMETER	FROM (INPUT)	TO (OUTPUT)	$V_{CCB} = 1.8 \text{ V} \pm 0.15 \text{ V}$		$V_{CCB} = 2.5 \text{ V} \pm 0.2 \text{ V}$		$V_{CCB} = 3 \text{ V} \pm 0.3 \text{ V}$		$V_{CCB} = 3.3 \text{ V} \pm 0.3 \text{ V}$		UNIT
			MIN	MAX	MIN	MAX	MIN	MAX	MIN	MAX	
t_{pd}	A	B	1	7.7	1	4.9	1	4.7	1	4.4	ns
	B	A	1	6.3	1	5	1	5	1	5	
	CLK.h or SCLK.h	CLK.0 or SCLK.0	1	7.7	1	5	1	4.9	1	4.9	
	CLK.h or SCLK.h	CLK-f.h or SCLK-f.h	2	19	2	12	2	10	2	9.7	
	CMD.h	CMD.0	1	7.1	1	4.1	1	3.9	1	3.6	
	CMD.h	CMD.1	1	7	1	4.6	1	4.1	1	4.2	
	CMD.0	CMD.h	1	6.2	1	4.9	1	4.8	1	4.7	
	$\overline{CS0}$	B	1	6	1	4.2	1	4.2	1	3.9	
	R/B	R/B.h	1	5.7	1	4.8	1	4.7	1	4.8	
	\overline{WE}	$\overline{WE.h}$	1	7.4	1	4.3	1	4.3	1	4.2	
\overline{WP}	$\overline{WP.h}$	1	6.6	1	4.5	1	4.4	1	4.3		
t_{en}	DAT1.0 or DATA1.0	\overline{IRQ}	1	4.8	1	3.3	1	3.3	1	3.3	ns
	DAT1.1 or DATA1.1	\overline{IRQ}	1	4.9	1	3.4	1	3.3	1	3.3	
	DIR	B	1	6.7	1	4.5	1	4.4	1	4.6	
	DIR	A	1	10.3	1	9.6	1	9.6	1	9.5	
	R/B	R/B.h (open drain)	1	5.9	1	5.4	1	5.4	1	5.4	
t_{dis}	DAT1.0 or DATA1.0	\overline{IRQ}	1	6.7	1	4.9	1	5.5	1	5.5	ns
	DAT1.1 or DATA1.1	\overline{IRQ}	1	6.5	1	4.7	1	5.4	1	5.4	
	DIR	B	1	6.9	1	6.4	1	6.4	1	6.3	
	DIR	A	1	5.3	1	5.3	1	5.3	1	5.2	
	R/B	R/B.h (open drain)	1	16.9	1	17.4	1	5.3	1	4.1	

maximum frequency and output skew over recommended operating free-air temperature range,
 $V_{CCA} = 1.5 \text{ V} \pm 0.1 \text{ V}$ (see Figure 5)

PARAMETER	FROM (INPUT)	TO (OUTPUT)	$V_{CCB} = 3 \text{ V} \pm 0.3 \text{ V}$		$V_{CCB} = 3.3 \text{ V} \pm 0.3 \text{ V}$		UNIT
			MIN	MAX	MIN	MAX	
f_{max}	Clock	A	52		52		MHz
		B	52		52		
	Data	A	26		26		
		B	26		26		
$t_{sk(o)}$	A	1.5		1.5		ns	



SN74AVCA406
MMC, SD CARD, Memory Stick™, SmartMedia, AND xD-Picture Card™
±15-kV ESD-PROTECTED VOLTAGE-TRANSLATION TRANSCEIVER
SCES615B – OCTOBER 2004 – REVISED DECEMBER 2004

switching characteristics over recommended operating free-air temperature range,
V_{CCA} = 1.8 V ± 0.15 V (see Figure 5)

PARAMETER	FROM (INPUT)	TO (OUTPUT)	V _{CCB} = 1.8 V ± 0.15 V		V _{CCB} = 2.5 V ± 0.2 V		V _{CCB} = 3 V ± 0.3 V		V _{CCB} = 3.3 V ± 0.3 V		UNIT
			MIN	MAX	MIN	MAX	MIN	MAX	MIN	MAX	
t _{pd}	A	B	1	7.5	1	4.6	1	4.1	1	3.7	ns
	B	A	1	4.6	1	4.2	1	4.1	1	4	
	CLK.h or SCLK.h	CLK.0 or SCLK.0	1	8	1	4.8	1	4.3	1	4.2	
	CLK.h or SCLK.h	CLK-f.h or SCLK-f.h	2	17.9	2	9.4	2	8.7	2	8.3	
	CMD.h	CMD.0	1	7.4	1	3.7	1	3.3	1	3.3	
	CMD.h	CMD.1	1	6.2	1	4.4	1	3.7	1	3.5	
	CMD.0	CMD.h	1	4.5	1	4	1	3.8	1	3.8	
	$\overline{CS0}$	B	1	6.6	1	4	1	4	1	3.8	
	R/B	R/B.h	1	4.4	1	4	1	3.8	1	3.8	
	\overline{WE}	$\overline{WE.h}$	1	7.3	1	3.9	1	3.8	1	3.7	
	\overline{WP}	$\overline{WP.h}$	1	5.6	1	4	1	3.6	1	3.8	
t _{en}	DAT1.0 or DATA1.0	\overline{IRQ}	1	5	1	3.3	1	3.3	1	3.3	ns
	DAT1.1 or DATA1.1	\overline{IRQ}	1	4.6	1	3.1	1	3.1	1	3.1	
	DIR	B	1	6.4	1	3.8	1	3.6	1	3.6	
	DIR	A	1	7.7	1	6.9	1	6.9	1	6.9	
	R/B	R/B.h (open drain)	1	4.4	1	4.1	1	4.1	1	4.1	
t _{dis}	DAT1.0 or DATA1.0	\overline{IRQ}	1	6.5	1	4.8	1	5.5	1	5.5	ns
	DAT1.1 or DATA1.1	\overline{IRQ}	1	6.6	1	4.8	1	5.3	1	5.3	
	DIR	B	1	6.3	1	5.4	1	5.7	1	5.7	
	DIR	A	1	5.2	1	5.3	1	5.2	1	5.2	
	R/B	R/B.h (open drain)	1	15.9	1	19.5	1	5.6	1	3.8	

maximum frequency and output skew over recommended operating free-air temperature range,
V_{CCA} = 1.8 V ± 0.15 V (see Figure 5)

PARAMETER	FROM (INPUT)	TO (OUTPUT)	V _{CCB} = 3 V ± 0.3 V		V _{CCB} = 3.3 V ± 0.3 V		UNIT
			MIN	MAX	MIN	MAX	
f _{max}	Clock	A	52		52		MHz
		B	52		52		
	Data	A	26		26		
		B	26		26		
t _{sk(o)}	A	0.8		0.8		ns	

SN74AVCA406

MMC, SD CARD, Memory Stick™, SmartMedia, AND xD-Picture Card™

±15-kV ESD-PROTECTED VOLTAGE-TRANSLATION TRANSCEIVER

SCES615B – OCTOBER 2004 – REVISED DECEMBER 2004

switching characteristics over recommended operating free-air temperature range,
 $V_{CCA} = 2.5 V \pm 0.2 V$ (see Figure 5)

PARAMETER	FROM (INPUT)	TO (OUTPUT)	$V_{CCB} = 2.5 V \pm 0.2 V$		$V_{CCB} = 3 V \pm 0.3 V$		$V_{CCB} = 3.3 V \pm 0.3 V$		UNIT
			MIN	MAX	MIN	MAX	MIN	MAX	
t_{pd}	A	B	1	4	1	3.4	1	3.1	ns
	B	A	1	3.7	1	3.5	1	3.6	
	CLK.h or SCLK.h	CLK.0 or SCLK.0	1	3.9	1	3.5	1	3.5	
	CLK.h or SCLK.h	CLK-f.h or SCLK-f.h	2	8.3	2	7.3	2	7	
	CMD.h	CMD.0	1	3.2	1	3.1	1	2.7	
	CMD.h	CMD.1	1	3.6	1	3	1	2.8	
	CMD.0	CMD.h	1	3	1	3	1	3	
	$\overline{CS0}$	B	1	4.2	1	3.7	1	3.3	
	R/B	R/B.h	1	3.1	1	3	1	2.9	
	\overline{WE}	$\overline{WE}.h$	1	3.6	1	3.4	1	3	
	\overline{WP}	$\overline{WP}.h$	1	3.5	1	3.1	1	2.9	
t_{en}	DAT1.0 or DATA1.0	\overline{IRQ}	1	3.3	1	3.3	1	3.2	ns
	DAT1.1 or DATA1.1	\overline{IRQ}	1	3.6	1	3.4	1	3.2	
	DIR	B	1	4.7	1	4.4	1	3.6	
	DIR	A	1	5.3	1	5.3	1	5.1	
	R/B	R/B.h (open drain)	1	3.2	1	3.1	1	3	
t_{dis}	DAT1.0 or DATA1.0	\overline{IRQ}	1	7.2	1	5.4	1	5.4	ns
	DAT1.1 or DATA1.1	\overline{IRQ}	1	7	1	5.4	1	5.4	
	DIR	B	1	4.5	1	5.1	1	5.1	
	DIR	A	1	3.7	1	3.7	1	3.7	
	R/B	R/B.h (open drain)	1	3.2	1	3.9	1	3.9	

maximum frequency and output skew over recommended operating free-air temperature range,
 $V_{CCA} = 2.5 V \pm 0.2 V$ (see Figure 5)

PARAMETER	FROM (INPUT)	TO (OUTPUT)	$V_{CCB} = 3 V \pm 0.3 V$		$V_{CCB} = 3.3 V \pm 0.3 V$		UNIT
			MIN	MAX	MIN	MAX	
f_{max}	Clock	A	52		52		MHz
		B	52		52		
	Data	A	26		26		
		B	26		26		
$t_{sk(o)}$	A	0.7		0.7		ns	

SN74AVCA406
MMC, SD CARD, Memory Stick™, SmartMedia, AND xD-Picture Card™
±15-kV ESD-PROTECTED VOLTAGE-TRANSLATION TRANSCEIVER
SCES615B – OCTOBER 2004 – REVISED DECEMBER 2004

switching characteristics over recommended operating free-air temperature range,
V_{CCA} = 3.3 V ± 0.3 V (see Figure 5)

PARAMETER	FROM (INPUT)	TO (OUTPUT)	V _{CCB} = 3.3 V ± 0.3 V		UNIT
			MIN	MAX	
t _{pd}	A	B	1	2.9	ns
	B	A	1	3.8	
	CLK.h or SCLK.h	CLK.0 or SCLK.0	1	3.3	
	CLK.h or SCLK.h	CLK-f.h or SCLK-f.h	2	6.1	
	CMD.h	CMD.0	1	2.7	
	CMD.h	CMD.1	1	2.7	
	CMD.0	CMD.h	1	2.6	
	$\overline{\text{CS}}_0$	B	1	3.7	
	R/B	R/B.h	1	2.5	
	$\overline{\text{WE}}$	$\overline{\text{WE}}$.h	1	3	
$\overline{\text{WP}}$	$\overline{\text{WP}}$.h	1	2.8		
t _{en}	DAT1.0 or DATA1.0	$\overline{\text{IRQ}}$	1	3.2	ns
	DAT1.1 or DATA1.1	$\overline{\text{IRQ}}$	1	3.2	
	DIR	B	1	3.7	
	DIR	A	1	4.7	
	R/B	R/B.h (open drain)	1	4.9	
t _{dis}	DAT1.0 or DATA1.0	$\overline{\text{IRQ}}$	1	5.3	ns
	DAT1.1 or DATA1.1	$\overline{\text{IRQ}}$	1	5.2	
	DIR	B	1	5	
	DIR	A	1	4.7	
	R/B	R/B.h (open drain)	1	6	

maximum frequency and output skew over recommended operating free-air temperature range,
V_{CCA} = 3.3 V ± 0.3 V (see Figure 5)

PARAMETER		FROM (INPUT)	TO (OUTPUT)	V _{CCB} = 3.3 V ± 0.3 V		UNIT
				MIN	MAX	
f _{max}	Clock	A	B	52		MHz
		B	A	52		
	Data	A	B	26		
		B	A	26		
t _{sk(o)}		A	B	0.7		ns

SN74AVCA406**MMC, SD CARD, Memory Stick™, SmartMedia, AND xD-Picture Card™
±15-kV ESD-PROTECTED VOLTAGE-TRANSLATION TRANSCEIVER**

SCES615B – OCTOBER 2004 – REVISED DECEMBER 2004

operating characteristics, $V_{CCA} = 1.8\text{ V}$, $V_{CCB} = 3\text{ V}$, $T_A = 25^\circ\text{C}$

PARAMETER			TEST CONDITIONS	TYP	UNIT
C_{pdA}	Power dissipation capacitance per transceiver, A-port input, B-port output	Outputs enabled	$C_L = 0$, $f = 10\text{ MHz}$	9	pF
		Outputs disabled		0.1	
	Power dissipation capacitance per transceiver, B-port input, A-port output	Outputs enabled		16	
		Outputs disabled		7.5	
C_{pdB0}	Power dissipation capacitance per transceiver, A-port input, B-port output	Outputs enabled	$C_L = 0$, $f = 10\text{ MHz}$	16.5	pF
		Outputs disabled		0.1	
	Power dissipation capacitance per transceiver, B-port input, A-port output	Outputs enabled		4	
		Outputs disabled		2	
C_{pdB1}	Power dissipation capacitance per transceiver, A-port input, B-port output	Outputs enabled	$C_L = 0$, $f = 10\text{ MHz}$	18	pF
		Outputs disabled		0.1	
	Power dissipation capacitance per transceiver, B-port input, A-port output	Outputs enabled		6	
		Outputs disabled		3	

PARAMETER MEASUREMENT INFORMATION

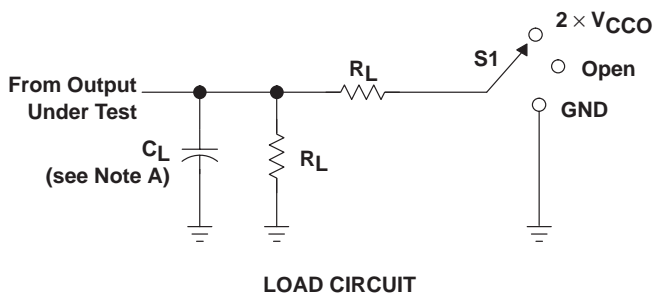

TEST	S1
t_{pd}	Open
t_{PLZ}/t_{PZL}	$2 \times V_{CCO}$
t_{PHZ}/t_{PZH}	GND
$t_{PLZ}/t_{PZL} (OD)$	$2 \times V_{CCO}$

V_{CCO}	C_L	R_L	V_{TP}
$1.5 \text{ V} \pm 0.1 \text{ V}$	15 pF	2 k Ω	0.1 V
$1.8 \text{ V} \pm 0.15 \text{ V}$	15 pF	2 k Ω	0.15 V
$2.5 \text{ V} \pm 0.2 \text{ V}$	15 pF	2 k Ω	0.15 V
$3.3 \text{ V} \pm 0.3 \text{ V}$	15 pF	2 k Ω	0.3 V

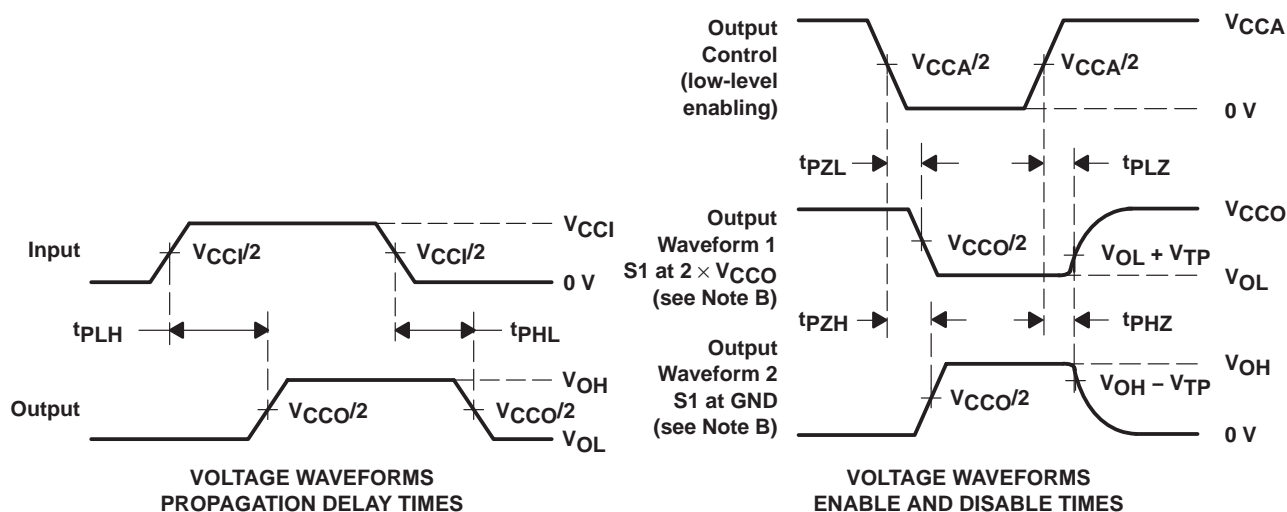

- NOTES:
- A. C_L includes probe and jig capacitance.
 - B. Waveform 1 is for an output with internal conditions such that the output is low, except when disabled by the output control. Waveform 2 is for an output with internal conditions such that the output is high, except when disabled by the output control.
 - C. All input pulses are supplied by generators having the following characteristics: $PRR \leq 10 \text{ MHz}$, $Z_O = 50 \Omega$, $dv/dt \geq 1 \text{ V/ns}$.
 - D. The outputs are measured one at a time, with one transition per measurement.
 - E. t_{PLZ} and t_{PHZ} are the same as t_{dis} .
 - F. t_{PZL} and t_{PZH} are the same as t_{en} .
 - G. t_{PLH} and t_{PHL} are the same as t_{pd} .
 - H. V_{CCI} is the V_{CC} associated with the input port.
 - I. V_{CCO} is the V_{CC} associated with the output port.

Figure 1. Load Circuit and Voltage Waveforms

SN74AVCA406

MMC, SD CARD, Memory Stick™, SmartMedia, AND xD-Picture Card™

±15-kV ESD-PROTECTED VOLTAGE-TRANSLATION TRANSCEIVER

SCES615B – OCTOBER 2004 – REVISED DECEMBER 2004

MECHANICAL DATA

GQC (S-PBGA-N48)

PLASTIC BALL GRID ARRAY

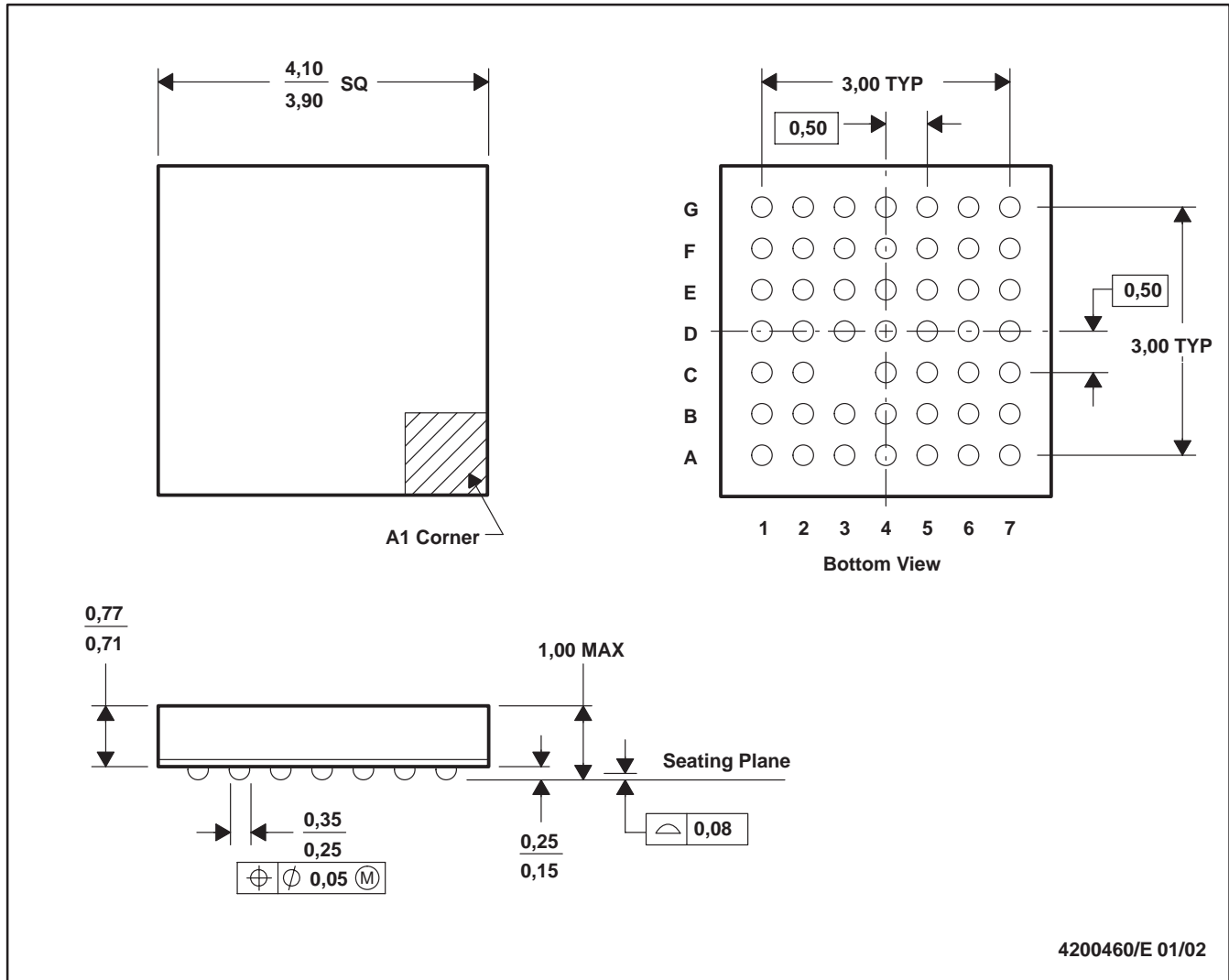

- NOTES:
- A. All linear dimensions are in millimeters.
 - B. This drawing is subject to change without notice.
 - C. MicroStar Jr.™ BGA configuration
 - D. Falls within JEDEC MO-225

MicroStar Jr. is a trademark of Texas Instruments.



POST OFFICE BOX 655303 • DALLAS, TEXAS 75265

GQC (S-PBGA-N48)

PLASTIC BALL GRID ARRAY

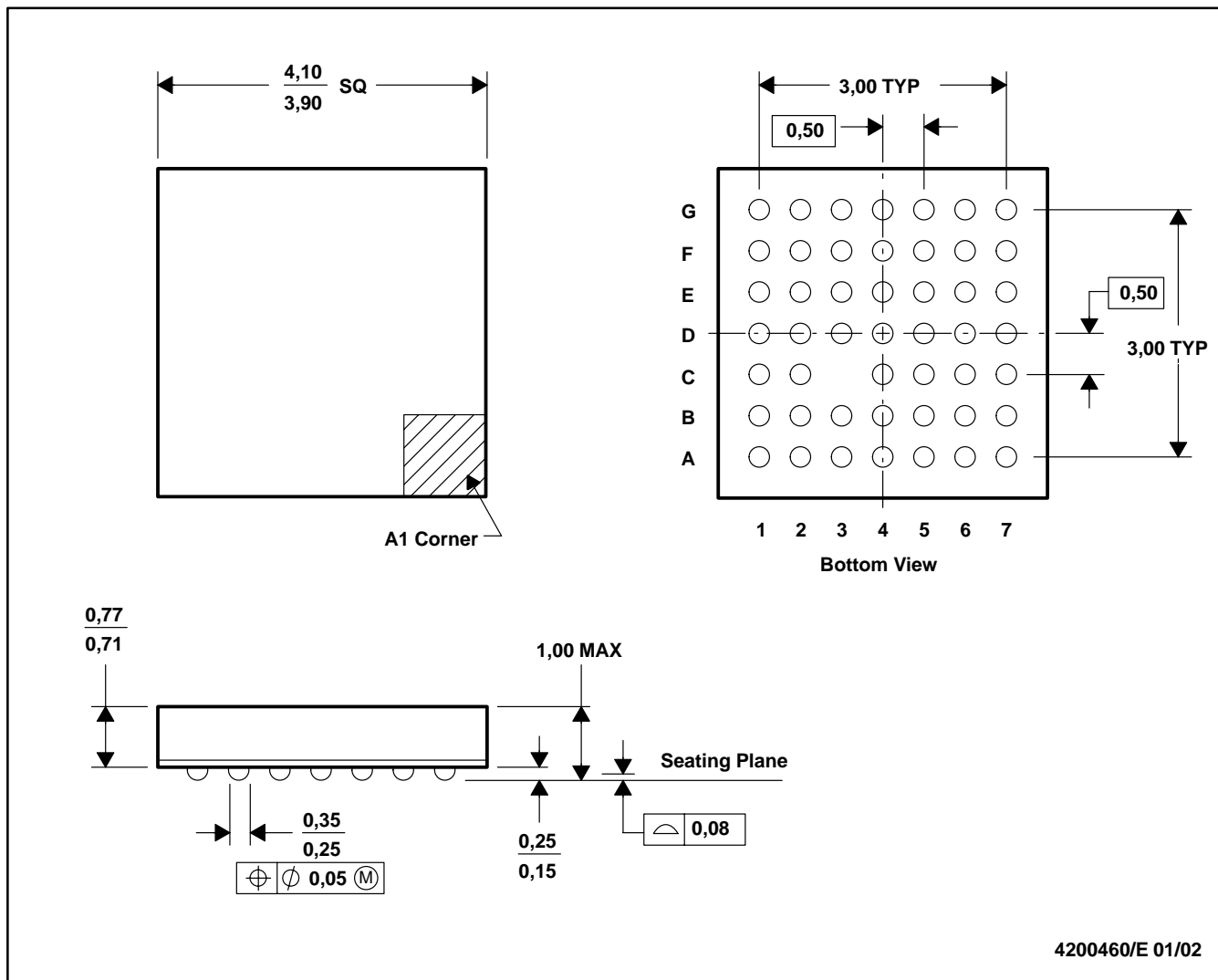

- NOTES: A. All linear dimensions are in millimeters.
 B. This drawing is subject to change without notice.
 C. MicroStar Junior™ BGA configuration
 D. Falls within JEDEC MO-225

MicroStar Junior is a trademark of Texas Instruments.

DGG (R-PDSO-G**)

PLASTIC SMALL-OUTLINE PACKAGE

48 PINS SHOWN



- NOTES: A. All linear dimensions are in millimeters.
 B. This drawing is subject to change without notice.
 C. Body dimensions do not include mold protrusion not to exceed 0,15.
 D. Falls within JEDEC MO-153

IMPORTANT NOTICE

Texas Instruments Incorporated and its subsidiaries (TI) reserve the right to make corrections, modifications, enhancements, improvements, and other changes to its products and services at any time and to discontinue any product or service without notice. Customers should obtain the latest relevant information before placing orders and should verify that such information is current and complete. All products are sold subject to TI's terms and conditions of sale supplied at the time of order acknowledgment.

TI warrants performance of its hardware products to the specifications applicable at the time of sale in accordance with TI's standard warranty. Testing and other quality control techniques are used to the extent TI deems necessary to support this warranty. Except where mandated by government requirements, testing of all parameters of each product is not necessarily performed.

TI assumes no liability for applications assistance or customer product design. Customers are responsible for their products and applications using TI components. To minimize the risks associated with customer products and applications, customers should provide adequate design and operating safeguards.

TI does not warrant or represent that any license, either express or implied, is granted under any TI patent right, copyright, mask work right, or other TI intellectual property right relating to any combination, machine, or process in which TI products or services are used. Information published by TI regarding third-party products or services does not constitute a license from TI to use such products or services or a warranty or endorsement thereof. Use of such information may require a license from a third party under the patents or other intellectual property of the third party, or a license from TI under the patents or other intellectual property of TI.

Reproduction of information in TI data books or data sheets is permissible only if reproduction is without alteration and is accompanied by all associated warranties, conditions, limitations, and notices. Reproduction of this information with alteration is an unfair and deceptive business practice. TI is not responsible or liable for such altered documentation.

Resale of TI products or services with statements different from or beyond the parameters stated by TI for that product or service voids all express and any implied warranties for the associated TI product or service and is an unfair and deceptive business practice. TI is not responsible or liable for any such statements.

Following are URLs where you can obtain information on other Texas Instruments products and application solutions:

Products		Applications	
Amplifiers	amplifier.ti.com	Audio	www.ti.com/audio
Data Converters	dataconverter.ti.com	Automotive	www.ti.com/automotive
DSP	dsp.ti.com	Broadband	www.ti.com/broadband
Interface	interface.ti.com	Digital Control	www.ti.com/digitalcontrol
Logic	logic.ti.com	Military	www.ti.com/military
Power Mgmt	power.ti.com	Optical Networking	www.ti.com/opticalnetwork
Microcontrollers	microcontroller.ti.com	Security	www.ti.com/security
		Telephony	www.ti.com/telephony
		Video & Imaging	www.ti.com/video
		Wireless	www.ti.com/wireless

Mailing Address: Texas Instruments
Post Office Box 655303 Dallas, Texas 75265