

Features

- DSL Triple Outputs: +15V, +3.3V, +1.5V (Independantly Regulated)
- Input Voltage Range: 36V to 75V
- 1500VDC Isolation
- On/Off "Standby" Control
- Current Limit
- Short Circuit Protection (All Outputs)
- Fixed Frequency Operation
- Over-Temperature Shutdown
- Under-Voltage Lockout
- Space Saving Package: 1.6 sq. in. PCB Area (suffix N)
- Solderable Copper Case
- Safety Agency Approvals: UL 60950, CSA C22.2 60950, VDE EN60950

Description

The PT4801 Excalibur™ module is an isolated triple-output DC/DC converter that provides +15V, +3.3V, and +1.5V power supply voltages from a standard (-48V) telecom central office (CO) supply. A typical application is a chip-set for an 8 or 16-channel ADSL/DSL line card, or other mixed signal circuitry. The output voltage combination provides power for a processor core, digital logic, and analog support circuitry. The Vo₂ and Vo₃ outputs are also designed to meet the power-up/down sequencing requirements of popular DSP ICs.

The PT4801 is housed in a space-saving solderable copper case. A heatsink is not required. The vertical configuration occupies only 1.6 in² of PCB area.

Ordering Information

PT4801□ = +15/+3.3/+1.5 Volts

PT Series Suffix (PT1234 x)

Case/Pin Configuration	Order Suffix	Package Code
Vertical	N	(ENJ)
Horizontal	A	(ENK)
SMD	C	(ENL)

(Reference the applicable package code drawing for the dimensions and PC board layout)

Pin-Out Information

Pin	Function	Pin	Function
1	Remote (On/Off)	11	COM
2	No Pin	12	Vo ₂ Adjust
3	-V _{in}	13	No Pin
4	-V _{in}	14	Vo ₂
5	N/C	15	Vo ₂
6	+V _{in}	16	COM
7	+V _{in}	17	COM
8	No Pin	18	Vo ₃
9	No Pin	19	Vo ₃ Adjust
10	Vo ₁	20	No Pin

Typical Application

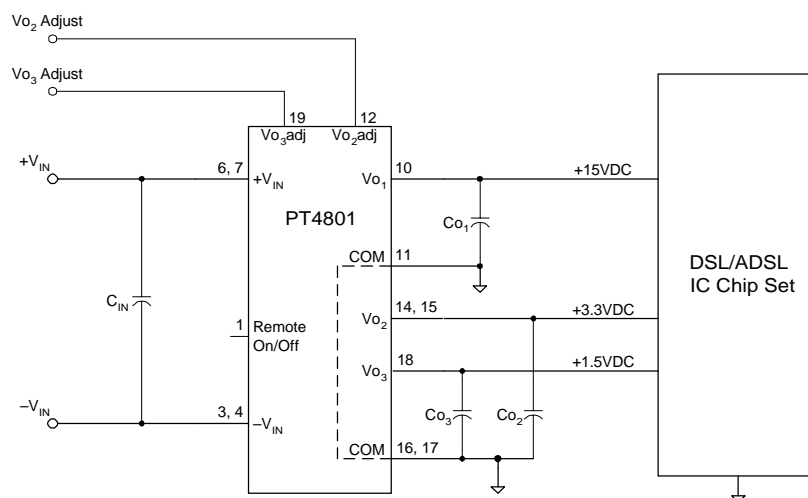

C_{in} = Optional 33μF
 Co₁/Co₂ = Optional 10μF to 330μF per output. (See note 6)

Electrical Specifications (Unless otherwise stated, $T_a = 25^\circ\text{C}$, $V_{in} = 48\text{V}$, $C_{in} = 0\mu\text{F}$, $C_{out} = 0\mu\text{F}$, and $I_o = I_{o\text{typ}}$)

Characteristics	Symbols	Conditions	PT4801 SERIES			Units	
			Min	Typ	Max		
Output Power	P_o	Each output:	V_{o1} (15V)	—	15	18.75 (1)	W
			V_{o2} (3.3V)	—	6.6	9.9 (1)	
			V_{o3} (1.5V)	—	2.25	3.0 (1)	
		All three outputs:		—	—	25 (1)	W
Output Current	I_o		V_{o1} (15V)	0	1.0	1.25	A
		($I_{o1} > 0.25\text{A}$)	V_{o2} (3.3V)	0	2.0	3.0 (2)	A
			V_{o3} (1.5V)	0	1.5	2.0 (2)	A
		($I_{o1} \leq 0.25\text{A}$)	V_{o2} (3.3V)	0	—	2.0 (2)	A
			V_{o3} (1.5V)	0	—	1.5 (2)	A
Input Voltage Range	V_{in}	Continuous		36	—	75	V
		Surge (1 minute)		—	—	80	V
Set-point Voltage Tolerance	$V_{o\text{tol}}$		V_{o1}	15.0	—	15.75	V
			V_{o2}	3.25	3.3	3.35	
			V_{o3}	1.45	1.5	1.55	
Temperature Variation	Reg_{temp}	$-40^\circ \leq T_a \leq +85^\circ\text{C}$, $I_o = I_{o\text{min}}$		—	± 0.5	—	% V_o
Line Regulation	Reg_{line}	All outputs, Over V_{in} range, $I_o = I_{o\text{typ}}$		—	0.5	1.0	% V_o
Load Regulation	Reg_{load}	All outputs, $I_o = 10\%$ to $100\%I_{o\text{max}}$		—	0.5	1.0	% V_o
Total Output Voltage Variation	ΔV_o , tot	Includes set-point, line load, $-40^\circ\text{C} \leq T_a \leq +85^\circ\text{C}$	V_{o1}	15.0	—	15.75	V
			V_{o2}	3.2	3.3	3.4	
			V_{o3}	1.4	1.5	1.6	
Efficiency	η	$I_{o1} = 0.5\text{A}$, $I_{o2} = 1.0\text{A}$, $I_{o3} = 1.0\text{A}$ $I_{o1} = 1.0\text{A}$, $I_{o2} = 3.0\text{A}$, $I_{o3} = 2.0\text{A}$		—	78 81	—	%
V_o Ripple (pk-pk)	V_r	20–20Mz bandwidth, $I_o = I_{o\text{typ}}$	V_{o1}	—	75	150	mV _{pp}
			V_{o2}	—	33	50	
			V_{o3}	—	30	50	
Transient Response	t_{tr} $V_{o\text{s}}$	25% load step from $I_o \geq 0.5I_{o\text{typ}}$ V_o over/undershoot	V_{o1}	—	300	—	μSec
			V_{o2}	—	100	150	mV _{pp}
			V_{o3}	—	100	150	
Output Voltage Adjust	$V_{o\text{adj}}$		V_{o2}	3.135	—	3.465	V
			V_{o3}	1.425	—	1.5 (4)	
Switching Frequency	f_s	Over V_{in} and I_o ranges		550	650	750	kHz
Under-Voltage Lockout	UVLO	V_{in} increasing		—	34	—	V
		V_{in} decreasing		—	33	—	
Remote On/Off (Pin x)		Referenced to $-V_{in}$ (pin 1)					
Input High Voltage	V_{IH}			2.5	—	15 (5)	V
Input Low Voltage	V_{IL}			–0.2	—	+0.8	
Input Low Current	I_{IL}			—	–10	—	μA
Standby Input Current	$I_{in\text{ standby}}$	pins 1 & 2 connected		—	8	16	mA
Internal Input Capacitance	C_{in}			—	0.76	—	μF
External Output Capacitance	C_{o1} , C_{o2} , C_{o3}		V_{o1}	0	—	330 (6)	μF
			V_{o2} & V_{o3} (each)	0	—	330 (6)	
Isolation Voltage		Input–output/input–case		1500	—	—	V
Capacitance		Input to output		—	3000	—	pF
Resistance		Input to output		10	—	—	$\text{M}\Omega$
Operating Temperature Range	T_a	Over V_{in} Range		–40	—	+85 (7)	$^\circ\text{C}$
Case Temperature						+100	$^\circ\text{C}$
Over Temperature Protection	OTP			+125			$^\circ\text{C}$
Storage Temperature	T_s			–40	—	+125	$^\circ\text{C}$
Mechanical Shock		Method 2002.3		—	500	—	G's
Mil-STD-883D,		1 msec, ½ Sine, mounted					
Mechanical Vibration		Method 2007.2,	Suffixes A, C	—	20 (8)	—	G's
Mil-STD-883D		20–2000 Hz, Soldered					
Weight	—	Vertical/Horizontal		—	50	—	grams
Flammability	—	Meets UL 94V-O					

Notes: (1) The sum-total power delivered from all three output, V_{o1} , V_{o2} , and V_{o3} cannot exceed 25 watts.

(2) When the load current from V_{o1} is less than 0.25A, the maximum current available from V_{o2} , and V_{o3} is reduced to 2A and 1.5A respectively.

(3) The sum-total current from all three outputs V_{o1} , V_{o2} , and V_{o3} cannot exceed 6Adc.

(4) V_{o3} cannot be adjusted higher than the nominal output voltage. Consult the applicable application note for information on output voltage adjustment.

(5) The Remote On/Off input has an internal pull-up. If left open circuit the PT4801 will operate when input power is applied. A low-leakage (<100nA) MOSFET is recommended to control this input. The open-circuit voltage is less than 10V. See application notes for interface considerations.

(6) External output capacitance is not required for proper operation. Up to 100 μF of external capacitance may be added to each output to improve the response to load transients. Do not exceed 330 μF at any one output. Allowances must be made for load circuit capacitance and the total external capacitor tolerance. Excessive output capacitance will affect converter start up. Low ESR capacitors, including Os-con® and tantalum types, may be used.

(7) See Safe Operating Area curves, or consult the factory for the appropriate derating.

(8) The case pins on the through-hole package types (suffixes A & N) must be soldered. For more information, see the applicable package outline drawing.

25-W Triple Output Isolated DC/DC Converter for DSL Applications

PT4801 Characteristic Data (See Note A)

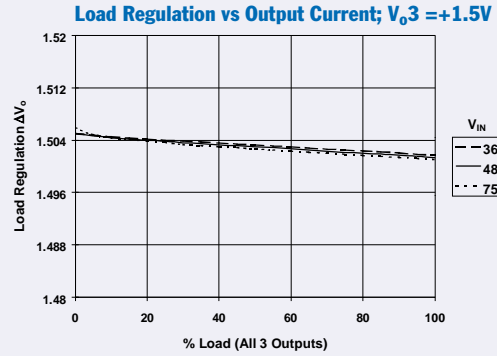
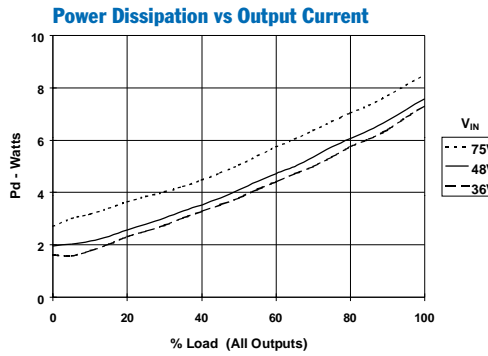
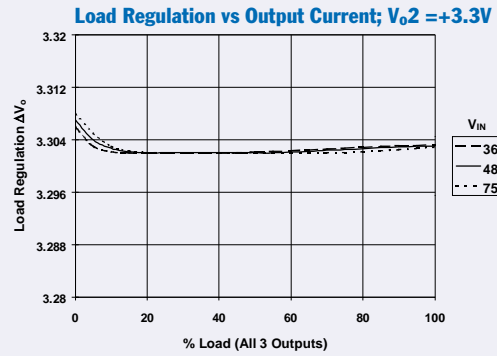
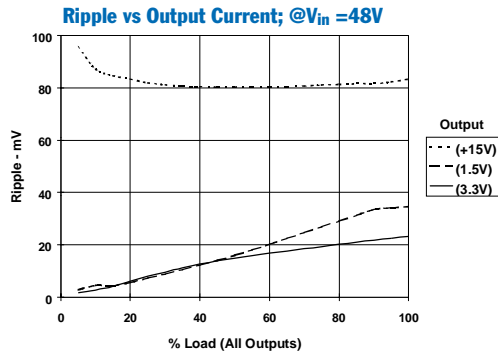
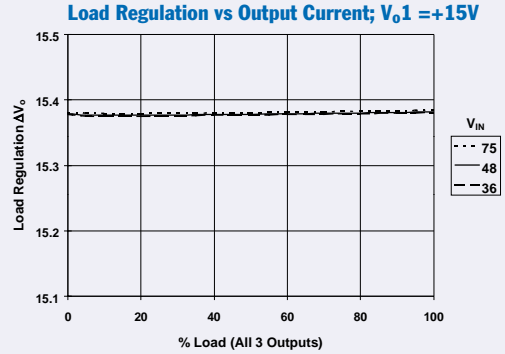
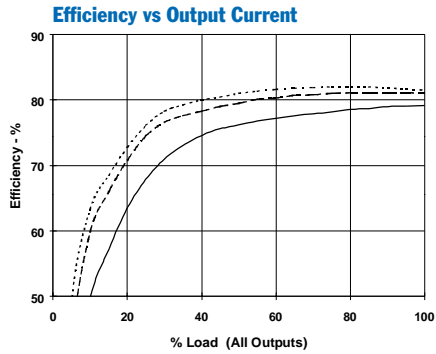

Safe Operating Area, $V_{in} = 48V$ (See Note B)

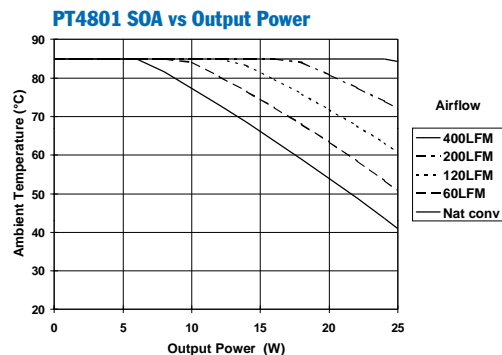

Note A: All Characteristic data in the above graphs has been developed from actual products tested at 25°C. This data is considered typical data for the ISR.
Note B: SOA curves represent operating conditions at which internal components are at or below manufacturer's maximum rated operating temperatures.

Using the Remote On/Off Control on the PT4801 Triple-Output Voltage DC/DC Converter

The three output voltages of the PT4801 triple-output DC/DC converter may be simultaneously disabled using the *Remote On/Off* control. This control is used in applications that require power-up/shutdown sequencing, or wherever there is a requirement to control the on/off status of the module with external circuitry.

On/off control of the PT4801 is provided by pin 1. If pin 1 is left open-circuit the regulator operates normally, and provides a regulated output at all three outputs, V_{O1} (pin 10), V_{O2} (pins 14, 15), and V_{O3} (pin 18), whenever a valid input voltage is applied to $\pm V_{in}$. If a low voltage is then applied to pin 1, the module's output will be disabled and the input current it draws will drop to a typical value of 8mA. The *Remote On/Off* input may also be used to hold the module's output in the 'off' state during the period that input power is applied. The input is ideally controlled using an open-collector (or open-drain) discrete transistor (See Figure 1) ³.

Table 1 Remote On/Off Control Parameters ^{1,2}

Parameter	Min	Typ	Max
Enable (V_{IH})	2.5V	—	15V ³
Disable (V_{IL})	-0.1V	—	0.8V

Notes:

1. The *Remote On/Off* input uses $-V_{in}$ (pins 3 & 4) as a ground reference, and cannot be directly controlled from circuitry referenced to the isolated output $\pm V_o$.
2. The internal circuitry comprises of a high impedance ($3\mu A$ - $10\mu A$) current source. The open-circuit voltage is less than 10V.
3. A low-leakage MOSFET ($<100nA$) is recommended. A pull-up resistor is not required, but may be necessary to ensure that the *Remote On/Off* pin exceeds $V_{IH}(\min)$ (see Table 1). Do not use a pull-up resistor to the $+V_{in}$ input, or drive the pin above $V_{IH}(\max)$.
4. The PT4801 converter incorporates an "Under Voltage Lockout" (UVLO) function. This function will override the *Remote On/Off* control until the input voltage applied to $\pm V_{in}$, is above the UVLO threshold. Consult the data sheet specifications for the on/off input voltage thresholds.
5. Keep the on/off transition to less than 1ms. This prevents erratic operation of the converter, whereby the output voltage may drift un-regulated between 0V and the rated output voltage during power-up.

6. In Figure 1, Q_1 is a low-threshold MOSFET. The components R_g and C_{gs} are added to improve noise immunity.

Figure 1

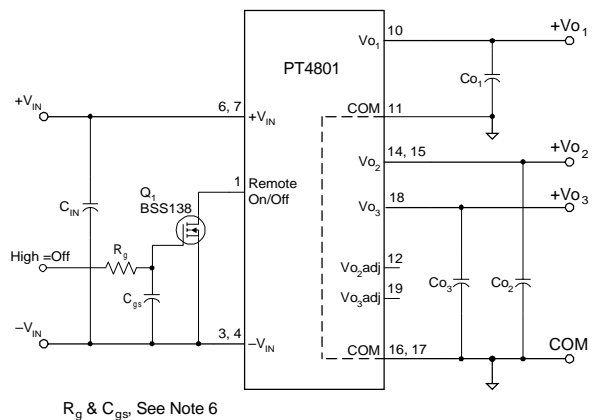

Power-Up Sequence: Turning Q_1 in Figure 1 off, removes the low-voltage signal at pin 1 and enables the outputs of the PT4801 converter. After a delay of about 5ms, the V_{O1} output will begin to rise first. This is closely followed by V_{O2} , and V_{O3} , which are internally sequenced to rise in unison. The total power-up time is less than 25ms and is relatively independent of load, and temperature. Figure 2 shows waveforms of all three output voltages, V_{O1} , V_{O2} , and V_{O3} following Q_1 turning off. The turn off of Q_1 corresponds to the fall in the applied V_{gs} . The waveforms were measured with a 48V input voltage.

Figure 2

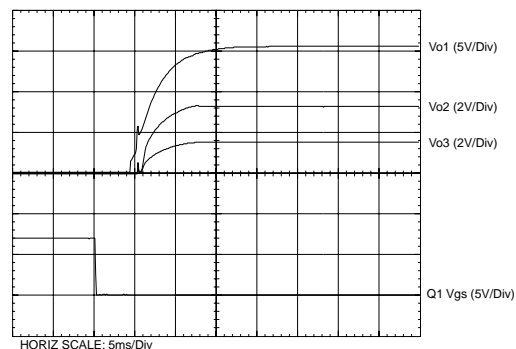

Adjusting the Output Voltage of the PT4801 Triple-Output DC/DC Converter

The low-voltage outputs from the PT4801 triple-output DC/DC converter, V_{O2} (3.3V) and V_{O3} (1.5V), can be independently adjusted from the factory trimmed preset value. Note that the primary use of this feature is for margin testing of the on-board supply voltages. A permanent increase in output voltage is not advised ¹. Also, due to design limitations, V_{O3} cannot be adjusted higher than its nominal value.

To adjust each output, a single external resistor is added to the circuit in either the “Adjust Up” or “Adjust Down” position (See Figure 1) ². Table 1 gives the allowable adjustment range for each output as V_a (min) and V_a (max).

V_{O2} Adjust Up: Add a resistor R_2 between pin 12 (V_{O2} Adj), and pin 11 (COM) ¹.

V_{O2} Adjust Down: Add a resistor (R_1) between pin 12 (V_{O2} Adj), and pin 14 (V_{O2}).

V_{O3} Adjust Up: V_{O3} cannot be adjusted higher.

V_{O3} Adjust Down: Add a resistor (R_3) between pin 19 (V_{O3} Adj), and pin 18 (V_{O3}).

Refer to Figure 1 and Table 2 for both the placement and value of the adjust resistor.

Notes:

1. The high-side adjust range of the V_{O2} output may be limited by the input voltage and/or the load current status of all three outputs. This situation would most likely be encountered when V_{O1} is lightly loaded and either V_{O2} or V_{O3} is operating close to full load.
2. Use only a single 1% resistor in either the (R_1) or R_2 location to adjust V_{O2} , and in the (R_3) location to adjust V_{O3} . Place the resistor as close to the ISR as possible.
3. Never connect capacitors to either of the output adjust control pins. Any capacitance added to these control pins will affect the stability of the respective regulated output.

The adjust up and adjust down resistor values can be calculated using the following formulas. Be sure to select the correct formula parameter from Table 1 for the output being adjusted.

$$(R_1) \text{ or } (R_3) = \frac{R_o (V_a - V_r)}{(V_o - V_a)} - R_s \text{ k}\Omega$$

$$R_2 = \frac{R_o \cdot V_r}{(V_a - V_o)} - R_s \text{ k}\Omega$$

Where V_o = Original output voltage
 V_a = Adjusted output voltage
 V_r = Reference voltage (Table 1)
 R_o = Multiplier resistor (Table 1)
 R_s = Series resistance (Table 1)

Figure 1

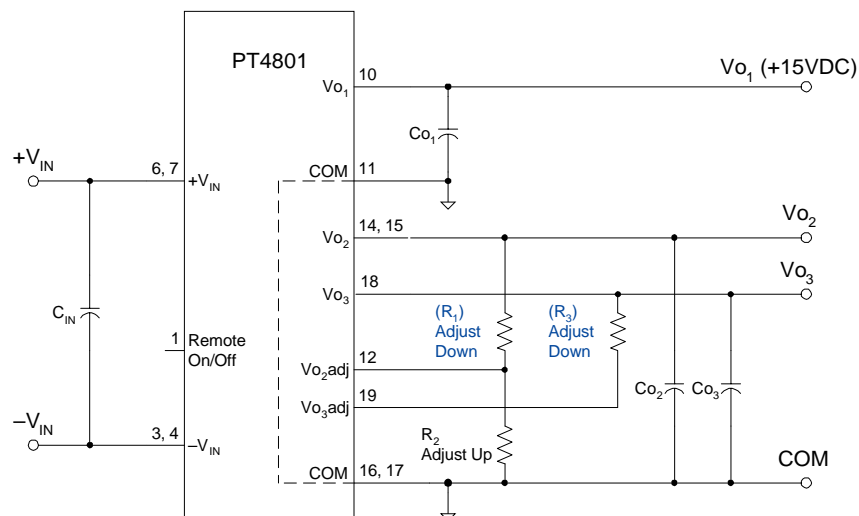

PT4801

Table 1

ADJUSTMENT RANGE AND FORMULA PARAMETERS		
Vo ₂ Bus		Vo ₃ Bus
Adj. Resistor	(R1)/R2	(R3)
V _o (nom)	3.3V	1.5V
V _a (min)	3.135V	1.425V
V _a (max)	3.465V *	—
V _r	1.225V	1.225V
R _o (V-kΩ)	11.0	7.5
R _s (kΩ)	40.2	5.36

* See Note 1

Table 2

ADJUSTMENT RESISTOR VALUES		
Vo ₁ Bus		Vo ₂ Bus
Adj. Resistor	(R1)/R2	Adj. Resistor (R3)
V _o (nom)	3.3V	V _o (nom) 1.5V
V _a (req'd)		V _a (req'd)
3.135	(87.1)kΩ	1.425 (14.6)kΩ
3.15	(101.0)kΩ	1.44 (21.5)kΩ
3.165	(118.0)kΩ	1.455 (33.0)kΩ
3.18	(139.0)kΩ	1.47 (55.9)kΩ
3.195	(166.0)kΩ	1.485 (125.0)kΩ
3.21	(202.0)kΩ	1.5
3.225	(253.0)kΩ	
3.24	(329.0)kΩ	
3.255	(456.0)kΩ	
3.27	(710.0)kΩ	
3.285		
3.3		
3.315		
3.33	409.0kΩ	
3.345	259.0kΩ	
3.36	184.0kΩ	
3.375	139.0kΩ	
3.39	110.0kΩ	
3.405	88.1kΩ	
3.42	72.1kΩ	
3.435	59.6kΩ	
3.45	49.6kΩ	
3.465	41.5kΩ	

R₁/R₃ = (Blue), R₂/R₄ = Black

VDE Approved Installation Instructions (Installationsanleitung)

Nennspannung (Rated Voltage): PT4801 36 to 72 Vdc, Transient to 80Vdc
Nennaufnahme (Rated Input): PT4801 1.5 Adc
Nennleistung (Rated Power): 25 Watts Maximum
Ausgangsspannung (Sec. Voltage): PT4801 Series
PT4801, +15/ +3.3/ +1.5 Vdc, 1.25 Adc/ 3.0 Adc/ 2.0 Adc
Ausgangsstrom (Sec. Current): Maximum total current is 6.0 Adc or 25 Watts
oder (or)
Ausgangsleistung (Sec. Power):

Angabe der Umgebungstemperatur

(Information on ambient temperature): +85 °C maximum

Besondere Hinweise (Special Instructions):

Es ist vorzusehen, daß die Spannungsversorgung in einer Endanwendung über eine isolierte Sekundärschaltung bereit gestellt wird. Die Eingangsspannung der Spannungsversorgungsmodule muss eine verstärkte Isolierung von der Wechselstromquelle aufweisen.

Die Spannungsversorgung muss gemäss den Gehäuse-, Montage-, Kriech- und Luftstrecken-, Markierungs- und Trennanforderungen der Endanwendung installiert werden. Bei Einsatz eines TNV-3-Einganges muss die SELV-Schaltung ordnungsgemäss geerdet werden.

(The power supply is intended to be supplied by isolated secondary circuitry in an end use application. The input power to these power supplies shall have reinforced insulation from the AC mains.)

The power supply shall be installed in compliance with the enclosure, mounting, creepage, clearance, casualty, markings, and segregation requirements of the end-use application. When the input is TNV-3, the SELV circuitry must be reliably grounded.)

Offenbach,

VDE Prüf- und Zertifizierungsinstitut
Abteilung / Department TD

(Jürgen Bärwinkel)

Ort / Place:

Datum / Date:

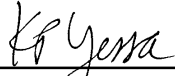
 12/12/01

(Stempel und Unterschrift des Herstellers / Stamp and signature of the manufacturer)

IMPORTANT NOTICE

Texas Instruments Incorporated and its subsidiaries (TI) reserve the right to make corrections, modifications, enhancements, improvements, and other changes to its products and services at any time and to discontinue any product or service without notice. Customers should obtain the latest relevant information before placing orders and should verify that such information is current and complete. All products are sold subject to TI's terms and conditions of sale supplied at the time of order acknowledgment.

TI warrants performance of its hardware products to the specifications applicable at the time of sale in accordance with TI's standard warranty. Testing and other quality control techniques are used to the extent TI deems necessary to support this warranty. Except where mandated by government requirements, testing of all parameters of each product is not necessarily performed.

TI assumes no liability for applications assistance or customer product design. Customers are responsible for their products and applications using TI components. To minimize the risks associated with customer products and applications, customers should provide adequate design and operating safeguards.

TI does not warrant or represent that any license, either express or implied, is granted under any TI patent right, copyright, mask work right, or other TI intellectual property right relating to any combination, machine, or process in which TI products or services are used. Information published by TI regarding third-party products or services does not constitute a license from TI to use such products or services or a warranty or endorsement thereof. Use of such information may require a license from a third party under the patents or other intellectual property of the third party, or a license from TI under the patents or other intellectual property of TI.

Reproduction of information in TI data books or data sheets is permissible only if reproduction is without alteration and is accompanied by all associated warranties, conditions, limitations, and notices. Reproduction of this information with alteration is an unfair and deceptive business practice. TI is not responsible or liable for such altered documentation.

Resale of TI products or services with statements different from or beyond the parameters stated by TI for that product or service voids all express and any implied warranties for the associated TI product or service and is an unfair and deceptive business practice. TI is not responsible or liable for any such statements.

Mailing Address:

Texas Instruments
Post Office Box 655303
Dallas, Texas 75265