

FEATURES

- Fixed 3.3-V, 5-V, 12-V, and 15-V Options With $\pm 5\%$ Regulation (Max) Over Line, Load, and Temperature Conditions
- Adjustable Option With a Range of 1.23 V to 37 V and $\pm 4\%$ Regulation (Max) Over Line, Load, and Temperature Conditions
- Specified 1-A Output Current
- Wide Input Voltage Range...4.75 V to 40 V
- Requires Only Four External Components (Fixed Versions) and Uses Readily Available Standard Inductors
- 52-kHz (Typ) Fixed-Frequency Internal Oscillator
- TTL Shutdown Capability With 50- μ A (Typ) Standby Current
- High Efficiency...as High as 88% (Typ)
- Thermal Shutdown and Current-Limit Protection With Cycle-by-Cycle Current Limiting

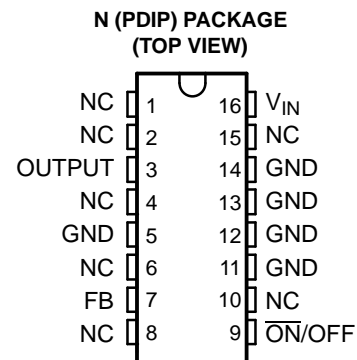
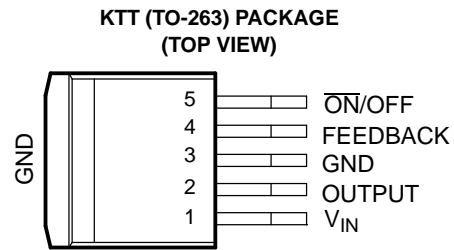

APPLICATIONS

- Simple High-Efficiency Step-Down (Buck) Regulator
- Pre-Regulator for Linear Regulators
- On-Card Switching Regulators
- Positive-to-Negative Converter (Buck-Boost)

DESCRIPTION/ORDERING INFORMATION

The LM2575 greatly simplifies the design of switching power supplies by conveniently providing all the active functions needed for a step-down (buck) switching regulator in an integrated circuit. Accepting a wide input voltage range and available in fixed output voltages of 3.3 V, 5 V, 12 V, 15 V, or an adjustable output version, the LM2575 has an integrated switch capable of delivering 1 A of load current, with excellent line and load regulation. The device also offers internal frequency compensation, a fixed-frequency oscillator, cycle-by-cycle current limiting, and thermal shutdown. In addition, a manual shutdown is available via an external $\overline{\text{ON/OFF}}$ pin.

The LM2575 represents a superior alternative to popular three-terminal linear regulators. Due to its high efficiency, it significantly reduces the size of the heat sink and, in many cases, no heat sink is required. Optimized for use with standard series of inductors available from several different manufacturers, the LM2575 greatly simplifies the design of switch-mode power supplies by requiring a minimal addition of only four to six external components for operation.

The LM2575 is characterized for operation over the virtual junction temperature range of -40°C to 125°C .



Please be aware that an important notice concerning availability, standard warranty, and use in critical applications of Texas Instruments semiconductor products and disclaimers thereto appears at the end of this data sheet.

LM2575

1-A SIMPLE STEP-DOWN SWITCHING VOLTAGE REGULATOR

SLVS569D–JANUARY 2005–REVISED JULY 2005

ORDERING INFORMATION

T_J	V_O (NOM)	PACKAGE ⁽¹⁾		ORDERABLE PART NUMBER	TOP-SIDE MARKING
–40°C to 125°C	3.3 V	PDIP – N	Tube of 25	LM2575-33IN	PREVIEW
	5 V			LM2575-05IN	PREVIEW
	12 V			LM2575-12IN	PREVIEW
	15 V			LM2575-15IN	PREVIEW
	ADJ			LM2575IN	LM2575IN
	3.3 V	TO-263 – KTT	Tube of 50	LM2575-33IKTT	PREVIEW
			Reel of 2000	LM2575-33IKTTR	
	5 V		Tube of 50	LM2575-05IKTT	PREVIEW
				Reel of 2000	
	12 V		Tube of 50	LM2575-12IKTT	PREVIEW
				Reel of 2000	
	15 V		Tube of 50	LM2575-15IKTT	PREVIEW
				Reel of 2000	
	ADJ		Tube of 50	LM2575IKTT	PREVIEW
		Reel of 2000	LM2575IKTTR		

(1) Package drawings, standard packing quantities, thermal data, symbolization, and PCB design guidelines are available at www.ti.com/sc/package.

FUNCTIONAL BLOCK DIAGRAM

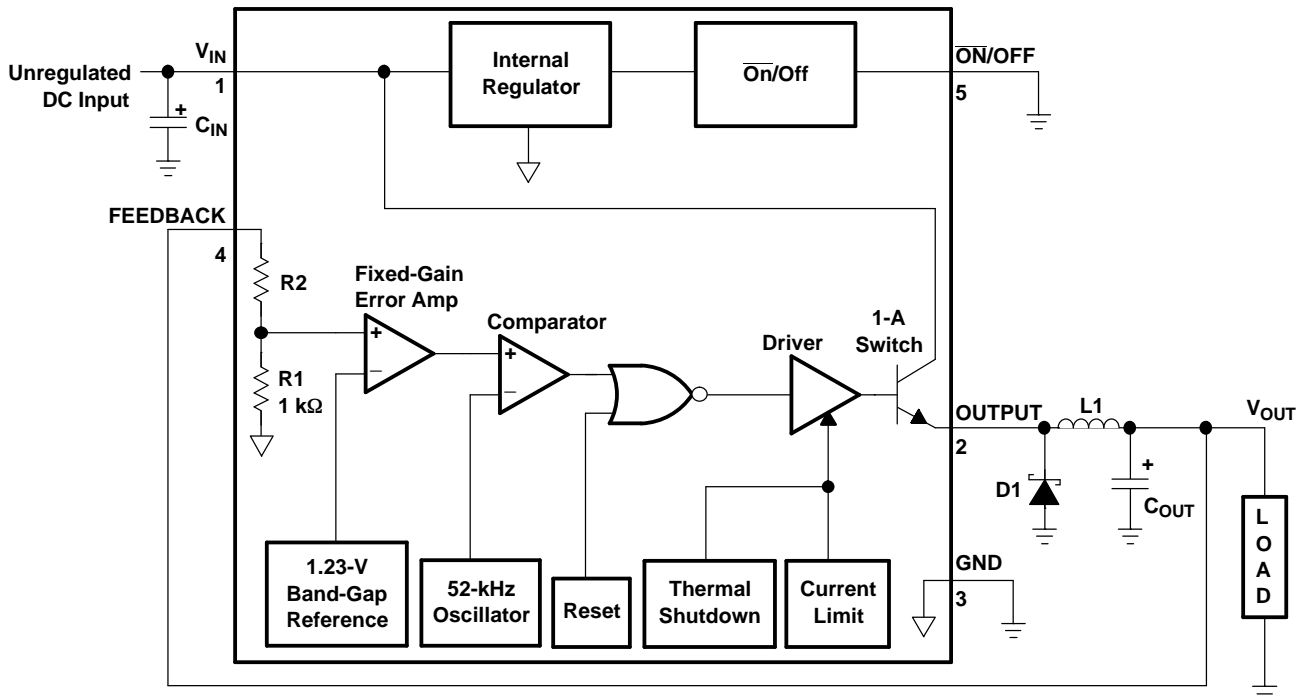

3.3 V: R2 = 1.7 kΩ
 5 V: R2 = 3.1 kΩ
 12 V: R2 = 8.84 kΩ
 15 V: R2 = 11.3 kΩ
 ADJ: R1 = Open, R2 = 0 Ω

A. Pin numbers are for the KTT (TO-263) package.

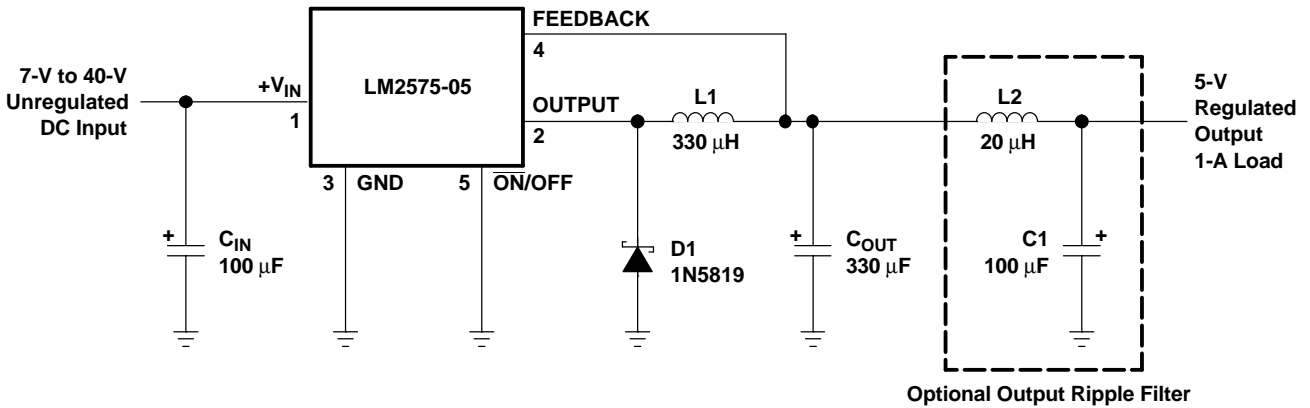

A. Pin numbers are for the KTT (TO-263) package.

Figure 1. Typical Application Circuit (Fixed Version)

LM2575

1-A SIMPLE STEP-DOWN SWITCHING VOLTAGE REGULATOR

SLVS569D–JANUARY 2005–REVISED JULY 2005

Absolute Maximum Ratings⁽¹⁾

over operating free-air temperature range (unless otherwise noted)

		MIN	MAX	UNIT
V_{IN}	Supply voltage		42	V
	\overline{ON} /OFF pin input voltage	-0.3	V_{IN}	V
	Output voltage to GND (steady state)		-1	V
T_J	Maximum junction temperature		150	°C
T_{stg}	Storage temperature range	-65	150	°C

(1) Stresses beyond those listed under “absolute maximum ratings” may cause permanent damage to the device. These are stress ratings only, and functional operation of the device at these or any other conditions beyond those indicated under “recommended operating conditions” is not implied. Exposure to absolute-maximum-rated conditions for extended periods may affect device reliability.

Package Thermal Data⁽¹⁾

PACKAGE	BOARD	θ_{JC}	θ_{JCB}	θ_{JA}
PDIP (N)	High K, JESD 51-7	51°C/W		67°C/W
TO-263 (KTT)	High K, JESD 51-5		TBD	TBD

(1) Maximum power dissipation is a function of $T_J(\max)$, θ_{JA} , and T_A . The maximum allowable power dissipation at any allowable ambient temperature is $P_D = (T_J(\max) - T_A)/\theta_{JA}$. Operating at the absolute maximum T_J of 150°C can affect reliability.

Recommended Operating Conditions

over operating free-air temperature range (unless otherwise noted)

		MIN	MAX	UNIT
V_{IN}	Supply voltage	4.75	40	V
T_J	Operating virtual junction temperature	-40	125	°C

Electrical Characteristics
 $I_{LOAD} = 200 \text{ mA}$, $V_{IN} = 12 \text{ V}$ for 3.3-V, 5-V, and adjustable versions, $V_{IN} = 25 \text{ V}$ for 12-V version, $V_{IN} = 30 \text{ V}$ for 15-V version (unless otherwise noted) (see Figure 2)

PARAMETER		TEST CONDITIONS	T_J	MIN	TYP	MAX	UNIT	
V_{OUT}	Output voltage	LM2575-33	$V_{IN} = 12 \text{ V}$, $I_{LOAD} = 0.2 \text{ A}$	25°C	3.234	3.3	3.366	V
			$4.75 \text{ V} \leq V_{IN} \leq 40 \text{ V}$, $0.2 \text{ A} \leq I_{LOAD} \leq 1 \text{ A}$	25°C	3.168	3.3	3.432	
			Full range		3.135		3.465	
		LM2575-05	$V_{IN} = 12 \text{ V}$, $I_{LOAD} = 0.2 \text{ A}$	25°C	4.9	5	5.1	
			$8 \text{ V} \leq V_{IN} \leq 40 \text{ V}$, $0.2 \text{ A} \leq I_{LOAD} \leq 1 \text{ A}$	25°C	4.8	5	5.2	
			Full range		4.75		5.25	
		LM2575-12	$V_{IN} = 25 \text{ V}$, $I_{LOAD} = 0.2 \text{ A}$	25°C	11.76	12	12.24	
			$15 \text{ V} \leq V_{IN} \leq 40 \text{ V}$, $0.2 \text{ A} \leq I_{LOAD} \leq 1 \text{ A}$	25°C	11.52	12	12.48	
			Full range		11.4		12.6	
		LM2575-15	$V_{IN} = 30 \text{ V}$, $I_{LOAD} = 0.2 \text{ A}$	25°C	14.7	15	15.3	
			$18 \text{ V} \leq V_{IN} \leq 40 \text{ V}$, $0.2 \text{ A} \leq I_{LOAD} \leq 1 \text{ A}$	25°C	14.4	15	15.6	
			Full range		14.25	15	15.75	
Feedback voltage	LM2575-ADJ	$V_{IN} = 12 \text{ V}$, $V_{OUT} = 5 \text{ V}$, $I_{LOAD} = 0.2 \text{ A}$	25°C	1.217	1.23	1.243	V	
		$8 \text{ V} \leq V_{IN} \leq 40 \text{ V}$, $V_{OUT} = 5 \text{ V}$, $0.2 \text{ A} \leq I_{LOAD} \leq 1 \text{ A}$	25°C	1.193	1.23	1.267		
		Full range		1.18		1.28		
η	Efficiency	LM2575-33	$V_{IN} = 12 \text{ V}$, $I_{LOAD} = 1 \text{ A}$	25°C		75	%	
		LM2575-05	$V_{IN} = 12 \text{ V}$, $I_{LOAD} = 1 \text{ A}$		77			
		LM2575-12	$V_{IN} = 15 \text{ V}$, $I_{LOAD} = 1 \text{ A}$		88			
		LM2575-15	$V_{IN} = 18 \text{ V}$, $I_{LOAD} = 1 \text{ A}$		88			
		LM2575-ADJ	$V_{IN} = 12 \text{ V}$, $V_{OUT} = 5 \text{ V}$, $I_{LOAD} = 1 \text{ A}$		77			
I_{IB}	Feedback bias current	$V_{OUT} = 5 \text{ V}$ (ADJ version only)	25°C		50	100	nA	
			Full range			500		
f_o	Oscillator frequency	(1)	25°C	47	52	58	kHz	
			Full range		42			63
V_{SAT}	Saturation voltage	$I_{OUT} = 1 \text{ A}^{(2)}$	25°C		0.9	1.2	V	
			Full range			1.4		
	Maximum duty cycle	(3)	25°C	93	98		%	
I_{CL}	Peak current	(1)(2)	25°C	1.7	2.8	3.6	A	
			Full range		1.3			4
I_L	Output leakage current	$V_{IN} = 40^{(4)}$, Output = 0 V	25°C			2	mA	
		$V_{IN} = 40^{(4)}$, Output = -1 V			7.5	30		
I_Q	Quiescent current	(4)	25°C		5	10	mA	
I_{STBY}	Standby quiescent current	OFF (\overline{ON}/OFF pin = 5 V)	25°C		50	200	μA	
V_{IH}	\overline{ON}/OFF logic input level	OFF ($V_{OUT} = 0 \text{ V}$)	25°C	2.2	1.4		V	
			Full range		2.4			
V_{IL}	\overline{ON}/OFF logic input level	ON ($V_{OUT} = \text{nominal voltage}$)	25°C		1.2	1		
			Full range					0.8
I_{IH}	\overline{ON}/OFF input current	OFF (\overline{ON}/OFF pin = 5 V)	25°C		12	30	μA	
		OFF (\overline{ON}/OFF pin = 0 V)			0	10		

(1) In the event of an output short or an overload condition, self-protection features lower the oscillator frequency to ~18 kHz and the minimum duty cycle from 5% to ~2%. The resulting output voltage drops to ~40% of its nominal value, causing the average power dissipated by the IC to lower.

(2) Output is not connected to diode, inductor, or capacitor. Output is sourcing current.

(3) Feedback is disconnected from output and connected to 0 V.

(4) To force the output transistor off, FEEDBACK is disconnected from output and connected to 12 V for the adjustable, 3.3-V, and 5-V versions; and 25 V for the 12-V and 15-V versions.

TYPICAL OPERATING CHARACTERISTICS

$T_A = 25^\circ\text{C}$ (unless otherwise noted)

GRAPH PREVIEWS

Figure 2. Normalized Output Voltage

Figure 3. Line Regulation

Figure 4. Dropout Voltage

Figure 5. Current Limit

Figure 6. Quiescent Current

Figure 7. Standby Quiescent Current

Figure 9. Quiescent Current vs Duty Cycle

Figure 0. Oscillator Frequency

Figure 10. Switch Saturation Voltage

Figure 11. Efficiency

Figure 12. Minimum Operating Voltage (Adjustable Version)

Figure 13. Feedback Voltage vs Duty Cycle

Figure 14. Feedback Pin Current (Adjustable Version)

Figure 15. Switching Waveforms

Figure 16. Load Transient Response

APPLICATION INFORMATION

Layout Guidelines

With any switching regulator, circuit layout plays an important role in circuit performance. Wiring and parasitic inductances, as well as stray capacitances, are subjected to rapidly switching currents, which can result in unwanted voltage transients. To minimize inductance and ground loops, the length of the leads indicated by heavy lines should be minimized. Optimal results can be achieved by single-point grounding (see Figure 2) or by ground-plane construction. For the same reasons, the two programming resistors used in the adjustable version should be located as close as possible to the regulator to keep the sensitive feedback wiring short.

Fixed Output Voltage Versions

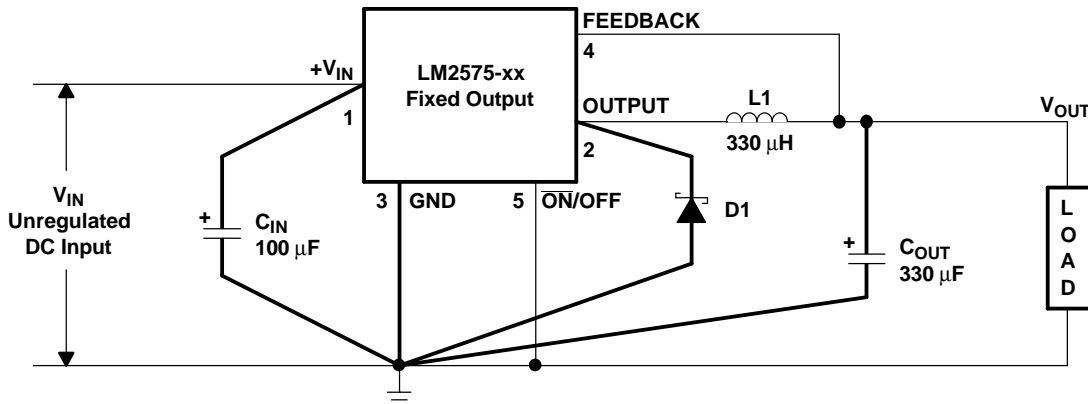

$C_{IN} = 100 \mu\text{F}$, Aluminum Electrolytic
 $C_{OUT} = 330 \mu\text{F}$, Aluminum Electrolytic
 D1 = Schottky
 L1 = $330 \mu\text{H}$

Adjustable Output Voltage Versions

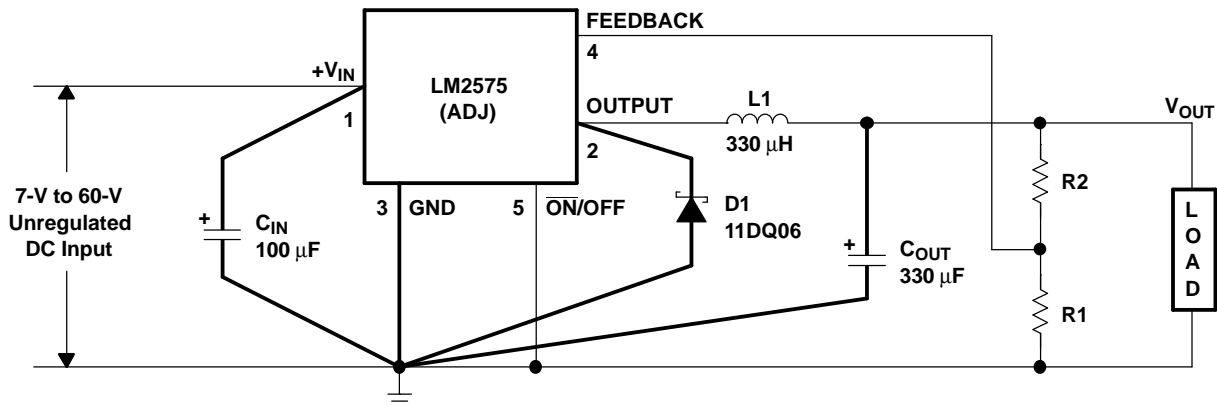

$$V_{OUT} = V_{REF}(1 + R2/R1) = 5 \text{ V}$$

Where,
 $V_{REF} = 1.23 \text{ V}$
 $R1 = 2 \text{ k}\Omega$
 $R2 = 6.12 \text{ k}\Omega$

A. Pin numbers are for the KTT (TO-263) package.

Figure 2. Test Circuit and Layout Guidelines

APPLICATION INFORMATION (continued)

Input Capacitor (C_{IN})

For stability concerns, an input bypass capacitor (electrolytic, $C_{IN} \geq 47 \mu\text{F}$) needs to be located as close as possible to the regulator. For operating temperatures below -25°C , C_{IN} may need to be larger in value. In addition, since most electrolytic capacitors have decreasing capacitances and increasing ESR as temperature drops, adding a ceramic or solid tantalum capacitor in parallel increases the stability in cold temperatures.

To extend the capacitor operating lifetime, the capacitor RMS ripple current rating should be:

$I_{C,RMS} > 1.2 \left(\frac{t_{on}}{T} \right) I_{LOAD}$, where:

$$\frac{t_{on}}{T} = \frac{V_{OUT}}{V_{IN}} \text{ \{buck regulator\}, and}$$

$$\frac{t_{on}}{T} = \frac{|V_{OUT}|}{(|V_{OUT}| + V_{IN})} \text{ \{buck-boost regulator\}}$$

Output Capacitor (C_{OUT})

For both loop stability and filtering of ripple voltage, an output capacitor also is required, again in close proximity to the regulator. For best performance, low-ESR aluminum electrolytics are recommended, although standard aluminum electrolytics may be adequate for some applications. Based on the following equation:

Output Ripple Voltage = (ESR of C_{OUT}) \times (inductor ripple current)

Output ripple of 50 mV to 150 mV typically can be achieved with capacitor values of 220 μF to 680 μF . Larger C_{OUT} can reduce the ripple 20 mV to 50 mV peak-to-peak. To improve further on output ripple, paralleling of standard electrolytic capacitors may be used. Alternatively, higher-grade capacitors such as “high frequency”, “low inductance”, or “low ESR” can be used.

The following should be taken into account when selecting C_{OUT} :

- At cold temperatures, the ESR of the electrolytic capacitors can rise dramatically (typically 3 \times nominal value at -25°C). Because solid tantalum capacitors have significantly better ESR specifications at cold temperatures, they should be used at operating temperature lower than -25°C . As an alternative, tantalums also can be paralleled to aluminum electrolytics and should contribute 10% to 20% to the total capacitance.
- Low ESR for C_{OUT} is desirable for low output ripple. However, the ESR should be greater than 0.05 Ω to avoid the possibility of regulator instability. Hence, a sole tantalum capacitor used for C_{OUT} is most susceptible to this occurrence.
- The capacitor’s ripple current rating of 52 kHz should be at least 50% higher than the peak-to-peak inductor ripple current.

Catch Diode

As with other external components, the catch diode should be placed close to the output to minimize unwanted noise. Schottky diodes have fast switching speeds and low forward voltage drops and, thus, offer the best performance, especially for switching regulators with low output voltages ($V_{OUT} < 5 \text{ V}$). If a high-efficiency, fast-recovery, or ultra-fast-recovery diode is used in place of a Schottky, it should have a soft recovery (versus abrupt turn-off characteristics) to avoid the chance of causing instability and EMI. Standard 50-/60-Hz diodes, such as the 1N4001 or 1N5400 series, are NOT suitable.

Inductor

Proper inductor selection is key to the performance-switching power-supply designs. One important factor to consider is whether the regulator will be used in continuous (inductor current flows continuously and never drops to zero) or in discontinuous mode (inductor current goes to zero during the normal switching cycle). Each mode has distinctively different operating characteristics and, therefore, can affect the regulator performance and requirements. In many applications, the continuous mode is the preferred mode of operation, since it offers greater output power with lower peak currents, and also can result in lower output ripple voltage. The advantages of continuous mode of operation come at the expense of a larger inductor required to keep inductor current continuous, especially at low output currents and/or high input voltages.

APPLICATION INFORMATION (continued)

The LM2575 can operate in either continuous or discontinuous mode. With heavy load currents, the inductor current flows continuously and the regulator operates in continuous mode. Under light load, the inductor fully discharges and the regulator is forced into the discontinuous mode of operation. For light loads (approximately 200 mA or less), this discontinuous mode of operation is perfectly acceptable and may be desirable solely to keep the inductor value and size small. Any buck regulator eventually will operate in discontinuous mode when the load current is light enough.

The type of inductor chosen can have advantages and disadvantages. If high performance/quality is a concern, then more-expensive toroid core inductors are the best choice, as the magnetic flux is contained completely within the core, resulting in less EMI and noise in nearby sensitive circuits. Inexpensive bobbin core inductors, however, generate more EMI as the open core will not confine the flux within the core. Multiple switching regulators located in proximity to each other are particularly susceptible to mutual coupling of magnetic fluxes from each other's open cores. In these situations, closed magnetic structures (such as a toroid, pot core, or E-core) are more appropriate.

Regardless of the type and value of inductor used, the inductor never should carry more than its rated current. Doing so may cause the inductor to saturate, in which case the inductance quickly drops, and the inductor looks like a low-value resistor (from the dc resistance of the windings). As a result, switching current rises dramatically (until limited by the current-by-current limiting feature of the LM2575) and can result in overheating of the inductor and the IC itself. Note that different types of inductors have different saturation characteristics.

Output Voltage Ripple and Transients

As with any switching power supply, the output of the LM2575 will have a sawtooth ripple voltage at the switching frequency. Typically about 1% of the output voltage, this ripple is due mainly to the inductor sawtooth ripple current and the ESR of the output capacitor (see note on C_{OUT}). Furthermore, the output also may contain small voltage spikes at the peaks of the sawtooth waveform. This is due to the fast switching of the output switch and the parasitic inductance of C_{OUT} . These voltage spikes can be minimized through the use of low-inductance capacitors.

There are several ways to reduce the output ripple voltage: a larger inductor, a larger C_{OUT} , or both. Another method is to use a small LC filter (20 μ H and 100 μ F) at the output. This filter can reduce the output ripple voltage by a factor of 10 (see [Figure 2](#)).

Feedback Connection

For fixed voltage options, FEEDBACK must be wired to V_{OUT} . For the adjustable version, FEEDBACK must be connected between the two programming resistors. Again, both of these resistors should be in close proximity to the regulator, and each should be less than 100 k Ω to minimize noise pickup.

$\overline{ON/OFF}$ Input

$\overline{ON/OFF}$ should be grounded or be a low-level TTL voltage (typically <1.6 V) for normal operation. To shut down the LM2575 and put it in standby mode, a high-level TTL or CMOS voltage should be supplied to this pin. $\overline{ON/OFF}$ should not be left open and safely can be pulled up to V_{IN} with or without a pullup resistor.

Grounding

The power and ground connections of the LM2575 must be low impedance to help maintain output stability. For the 5-pin packages, both pin 3 and tab are ground, and either connection can be used as they are both part of the same lead frame. With the 16-pin and 24-pin packages, all the ground pins (including signal and power grounds) should be soldered directly to wide PCB copper traces to ensure low-inductance connections and good thermal dissipation.

PACKAGING INFORMATION

Orderable Device	Status ⁽¹⁾	Package Type	Package Drawing	Pins	Package Qty	Eco Plan ⁽²⁾	Lead/Ball Finish	MSL Peak Temp ⁽³⁾
LM2575-33IN	PREVIEW	PDIP	N	16	25	TBD	Call TI	Call TI
LM2575IN	ACTIVE	PDIP	N	16	25	Pb-Free (RoHS)	CU NIPD	Level-NC-NC-NC
LM2575INE4	ACTIVE	PDIP	N	16	25	Pb-Free (RoHS)	CU NIPD	Level-NC-NC-NC

⁽¹⁾ The marketing status values are defined as follows:

ACTIVE: Product device recommended for new designs.

LIFEBUY: TI has announced that the device will be discontinued, and a lifetime-buy period is in effect.

NRND: Not recommended for new designs. Device is in production to support existing customers, but TI does not recommend using this part in a new design.

PREVIEW: Device has been announced but is not in production. Samples may or may not be available.

OBSOLETE: TI has discontinued the production of the device.

⁽²⁾ Eco Plan - The planned eco-friendly classification: Pb-Free (RoHS) or Green (RoHS & no Sb/Br) - please check <http://www.ti.com/productcontent> for the latest availability information and additional product content details.

TBD: The Pb-Free/Green conversion plan has not been defined.

Pb-Free (RoHS): TI's terms "Lead-Free" or "Pb-Free" mean semiconductor products that are compatible with the current RoHS requirements for all 6 substances, including the requirement that lead not exceed 0.1% by weight in homogeneous materials. Where designed to be soldered at high temperatures, TI Pb-Free products are suitable for use in specified lead-free processes.

Green (RoHS & no Sb/Br): TI defines "Green" to mean Pb-Free (RoHS compatible), and free of Bromine (Br) and Antimony (Sb) based flame retardants (Br or Sb do not exceed 0.1% by weight in homogeneous material)

⁽³⁾ MSL, Peak Temp. -- The Moisture Sensitivity Level rating according to the JEDEC industry standard classifications, and peak solder temperature.

Important Information and Disclaimer:The information provided on this page represents TI's knowledge and belief as of the date that it is provided. TI bases its knowledge and belief on information provided by third parties, and makes no representation or warranty as to the accuracy of such information. Efforts are underway to better integrate information from third parties. TI has taken and continues to take reasonable steps to provide representative and accurate information but may not have conducted destructive testing or chemical analysis on incoming materials and chemicals. TI and TI suppliers consider certain information to be proprietary, and thus CAS numbers and other limited information may not be available for release.

In no event shall TI's liability arising out of such information exceed the total purchase price of the TI part(s) at issue in this document sold by TI to Customer on an annual basis.

N (R-PDIP-T**)

PLASTIC DUAL-IN-LINE PACKAGE

16 PINS SHOWN



- NOTES:
- A. All linear dimensions are in inches (millimeters).
 - B. This drawing is subject to change without notice.
 - C. Falls within JEDEC MS-001, except 18 and 20 pin minimum body length (Dim A).
 - D. The 20 pin end lead shoulder width is a vendor option, either half or full width.

4040049/E 12/2002

IMPORTANT NOTICE

Texas Instruments Incorporated and its subsidiaries (TI) reserve the right to make corrections, modifications, enhancements, improvements, and other changes to its products and services at any time and to discontinue any product or service without notice. Customers should obtain the latest relevant information before placing orders and should verify that such information is current and complete. All products are sold subject to TI's terms and conditions of sale supplied at the time of order acknowledgment.

TI warrants performance of its hardware products to the specifications applicable at the time of sale in accordance with TI's standard warranty. Testing and other quality control techniques are used to the extent TI deems necessary to support this warranty. Except where mandated by government requirements, testing of all parameters of each product is not necessarily performed.

TI assumes no liability for applications assistance or customer product design. Customers are responsible for their products and applications using TI components. To minimize the risks associated with customer products and applications, customers should provide adequate design and operating safeguards.

TI does not warrant or represent that any license, either express or implied, is granted under any TI patent right, copyright, mask work right, or other TI intellectual property right relating to any combination, machine, or process in which TI products or services are used. Information published by TI regarding third-party products or services does not constitute a license from TI to use such products or services or a warranty or endorsement thereof. Use of such information may require a license from a third party under the patents or other intellectual property of the third party, or a license from TI under the patents or other intellectual property of TI.

Reproduction of information in TI data books or data sheets is permissible only if reproduction is without alteration and is accompanied by all associated warranties, conditions, limitations, and notices. Reproduction of this information with alteration is an unfair and deceptive business practice. TI is not responsible or liable for such altered documentation.

Resale of TI products or services with statements different from or beyond the parameters stated by TI for that product or service voids all express and any implied warranties for the associated TI product or service and is an unfair and deceptive business practice. TI is not responsible or liable for any such statements.

Following are URLs where you can obtain information on other Texas Instruments products and application solutions:

Products		Applications	
Amplifiers	amplifier.ti.com	Audio	www.ti.com/audio
Data Converters	dataconverter.ti.com	Automotive	www.ti.com/automotive
DSP	dsp.ti.com	Broadband	www.ti.com/broadband
Interface	interface.ti.com	Digital Control	www.ti.com/digitalcontrol
Logic	logic.ti.com	Military	www.ti.com/military
Power Mgmt	power.ti.com	Optical Networking	www.ti.com/opticalnetwork
Microcontrollers	microcontroller.ti.com	Security	www.ti.com/security
		Telephony	www.ti.com/telephony
		Video & Imaging	www.ti.com/video
		Wireless	www.ti.com/wireless

Mailing Address: Texas Instruments
Post Office Box 655303 Dallas, Texas 75265