

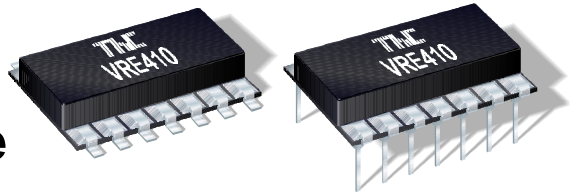

VRE410 Precision Dual Reference



THALER CORPORATION • 2015 N. FORBES BOULEVARD • TUCSON, AZ. 85745 • (520) 882-4000

FEATURES

- ± 10.000 V OUTPUT ± 1.000 mV (.01%)
- TEMPERATURE DRIFT: 0.6 ppm/°C
- LOW NOISE: $6\mu\text{V}_{\text{pp}}$ (0.1-10Hz)
- TRACKING ERROR: 0.5 mV max.
- EXCELLENT LINE REGULATION: 6ppm/V Typ.
- SURFACE MOUNT AND DIP PACKAGES

PIN CONFIGURATION

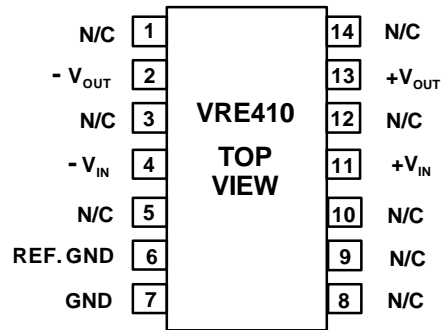

FIGURE 1

DESCRIPTION

The VRE410 is a low cost, high precision, ± 10.0 V reference. Packaged in 14 pin DIP or SMT packages, the device is ideal for new designs that need a high performance reference.

The device provides ultrastable ± 10.000 V output with ± 1.000 mV (.01%) initial accuracy and a temperature coefficient of 0.6 ppm/°C. This improvement in accuracy is made possible by a unique, patented multipoint laser compensation technique developed by Thaler Corporation.

Another key feature of this reference is the 0.5 mV maximum tracking error between the positive and negative output voltages over the full operating temperature range. This is extremely important in high performance systems for reducing overall system errors.

For designs which use the DIP package in a socket, there is a reference ground pin to eliminate reference ground errors.

The VRE410 is recommended for use as a reference for high precision D/A and A/D converters which require an external precision reference. The device is also ideal for calibrating scale factor on high resolution A/D converters. The VRE410 offers superior performance over monolithic references.

SELECTION GUIDE

Model	Initial Error mV	Temp. Coeff. ppm/°C	Temp. Range °C
VRE410A	1.0	0.6	0°C to +70°C
VRE410B	1.6	1.0	0°C to +70°C
VRE410C	2.0	2.0	0°C to +70°C
VRE410J	1.0	0.6	-40°C to +85°C
VRE410K	1.6	1.0	-40°C to +85°C
VRE410L	2.0	2.0	-40°C to +85°C

For package option add D for DIP or S for Surface Mount to end of model number.

ELECTRICAL SPECIFICATIONS

VRE410

Vps = ±15V, T = 25°C, RL = 10KΩ unless otherwise noted.

MODEL	A/J			B/K			C/L			
PARAMETER	MIN	TYP	MAX	MIN	TYP	MAX	MIN	TYP	MAX	UNITS
ABSOLUTE RATINGS										
Power Supply	±13.5	±15	±22	*	*	*	*	*	*	V
Operating Temp. (A,B,C)	0		+70	*		*	*		*	°C
Operating Temp. (J,K,L)	-40		+85	*		*	*		*	°C
Storage Temperature	-65		+150	*		*	*		*	°C
Short Circuit Protection	Continuous				*			*		
OUTPUT VOLTAGE										
VRE410		±10.00			*			*		V
OUTPUT VOLTAGE ERRORS										
Initial Error ⁽¹⁾			1.00			1.60			2.00	mV
Warmup Drift		1			2			3		ppm
T _{min} - T _{max} ⁽²⁾			0.6			1.0			2.0	ppm/°C
Tracking Error ⁽³⁾			0.5			0.7			1.0	mV
Long-Term Stability		6			*			*		ppm/1000hrs
Noise (.1-10Hz)		6			*			*		µVpp
OUTPUT CURRENT										
Range	±10			*			*			mA
REGULATION										
Line		3	10		*	*		*	*	ppm/V
Load		3			*			*		ppm/mA
POWER SUPPLY CURRENTS ⁽⁴⁾										
+PS		7	9		*	*		*	*	mA
-PS		4	6		*	*		*	*	mA

NOTES: *Same as A/J Models.

- The specified values are without external trim.
- The temperature coefficient (tc) is determined by the box method using the following formula:
- The tracking error is the deviation between the positive and negative output over the operating temp. range.
- The specified values are unloaded.

$$tc = \frac{V_{max} - V_{min}}{V_{nominal} \times (T_{max} - T_{min})} \times 10^6$$

TYPICAL PERFORMANCE CURVES

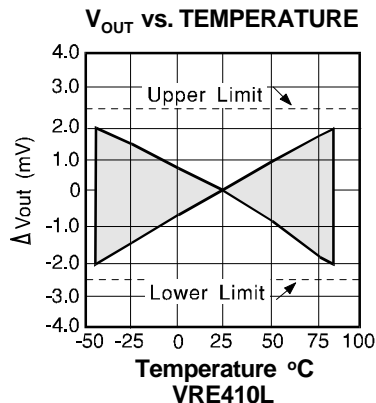
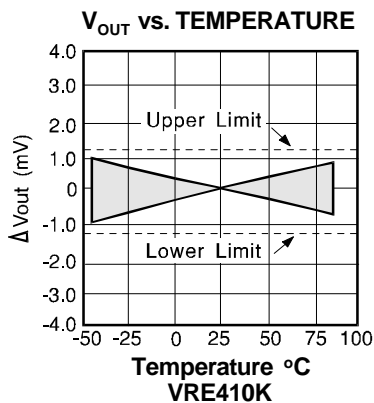
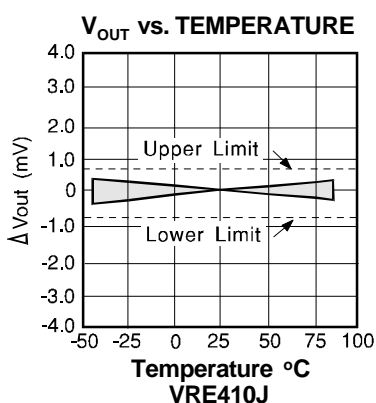
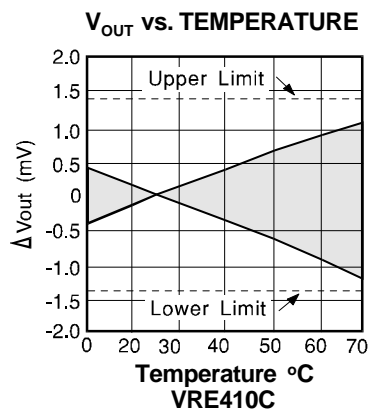
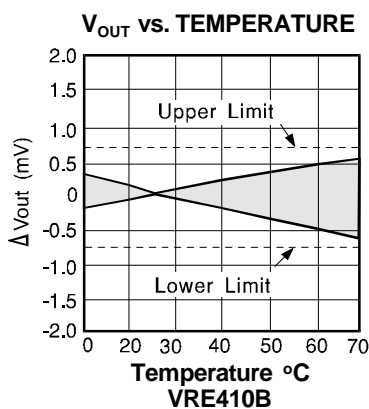
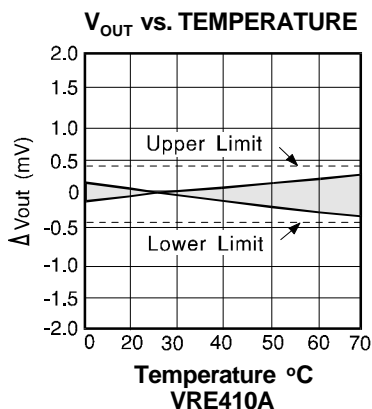

----- POSITIVE OUTPUT (TYP) -----

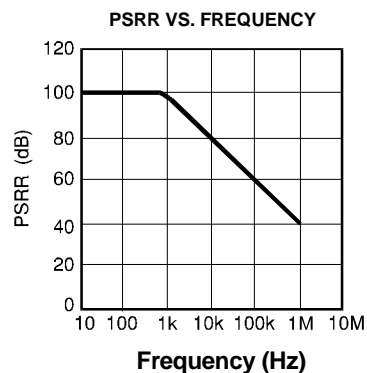
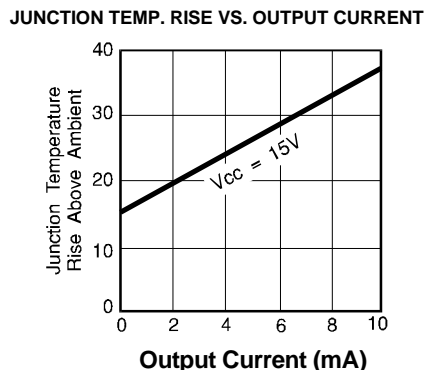
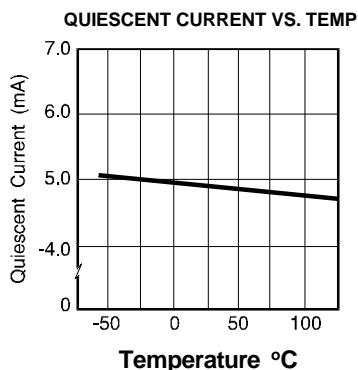

----- NEGATIVE OUTPUT (TYP) -----

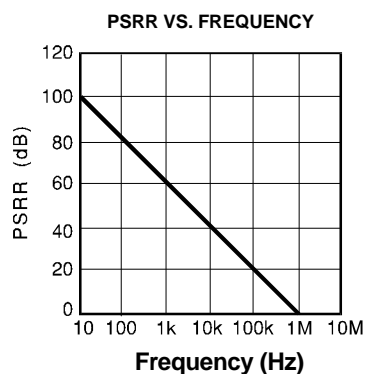
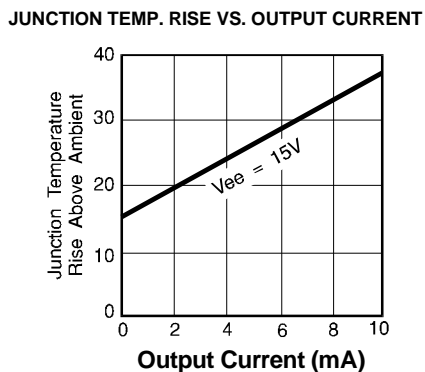
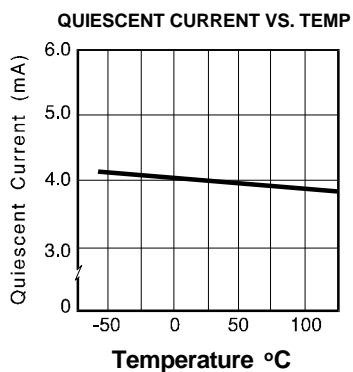

DISCUSSION OF PERFORMANCE

THEORY OF OPERATION

The following discussion refers to the schematic below. In operation, approximately 6.3 volts is applied to the noninverting input of the op amp. The voltage is amplified by the op amp to produce a 10.000V output. The gain is determined by the networks R1 and R2: $G=1 + R2/R1$. The 6.3V zener diode is used because it is the most stable diode over time and temperature.

The zener operating current is derived from the regulated output voltage through R3. This feedback arrangement provides a closely regulated zener current. This current determines the slope of the references' voltage vs. temperature function. By trimming the zener current a lower drift over temperature can be achieved. But since the voltage vs. temperature function is nonlinear this compensation technique is not well suited for wide temperature ranges.

Thaler Corporation has developed a nonlinear compensation network of thermistors and resistors that is used in the VRE series voltage references. This proprietary network eliminates most of the nonlinearity in the voltage vs. temperature function. By then adjusting the slope, Thaler Corporation produces a very stable voltage over wide temperature ranges.

The VRE400 series voltage references have the ground terminal brought out on two pins (pin 6 and 7) which are connected together internally. This allows the user to achieve greater accuracy when using a socket. Voltage references have a voltage drop across their power supply ground pin due to quiescent current flowing through the contact resistance. If the contact resistance was constant with time and temperature, this voltage drop could be trimmed out. When the reference is plugged into a socket, this source of error can be as high as 20ppm. By connecting pin 7 to the power supply ground and pin 6 to a high impedance ground point in the measurement circuit, the error due to the contact resistance can be eliminated. If the unit is soldered into place the contact resistance is sufficiently small that it doesn't effect performance.

VRE410

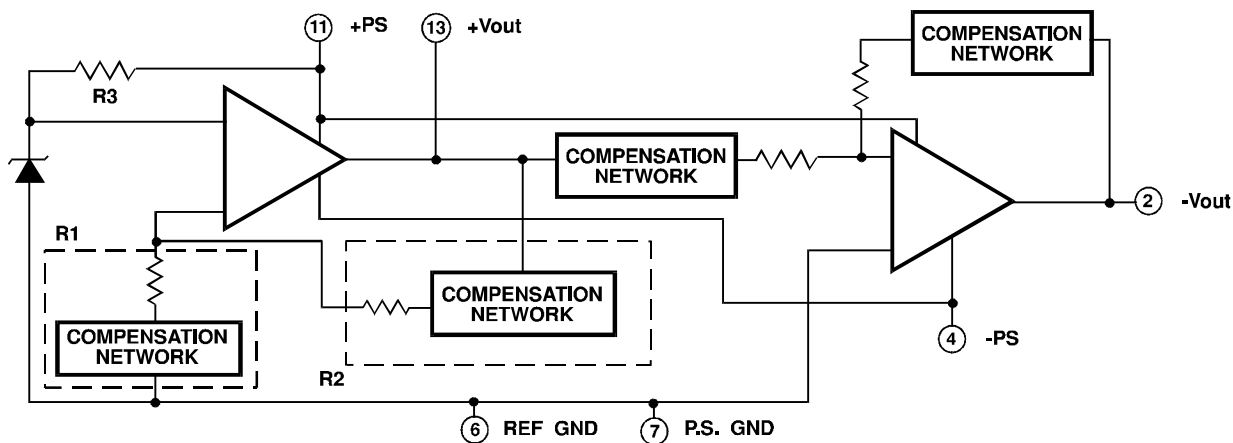
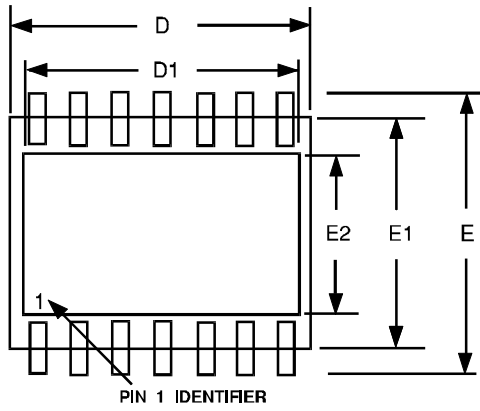

FIGURE 2

MECHANICAL

FIGURE 3



DIM	INCHES		MILLIMETER		DIM	INCHES		MILLIMETER	
	MIN	MAX	MIN	MAX		MIN	MAX	MIN	MAX
A	.114	.136	2.90	3.45	E	.495	.526	12.5	13.3
B	.098	.103	2.48	2.62	E1	.390	.415	9.91	10.5
B1	.047	.056	1.19	1.42	E2	.265	.270	6.73	6.86
C	.103	.118	2.62	3.00	P	.090	.110	2.29	2.79
C1	.009	.020	0.22	0.51	Q	.024	.035	0.61	.890
C2	.054	.062	1.37	1.57	S	.040	.060	1.02	1.52
D	.690	.715	17.5	18.1					
D1	.666	.680	16.9	17.2					

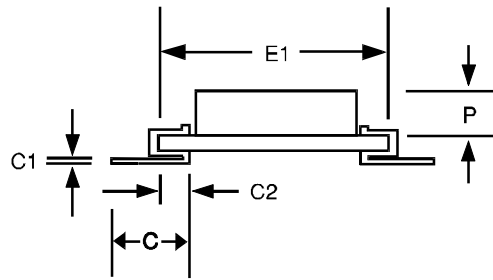
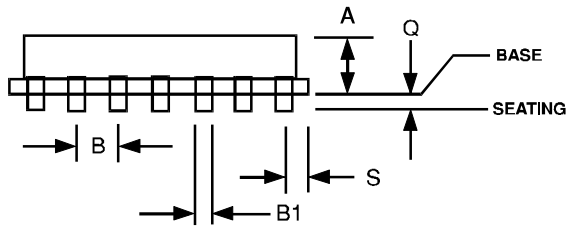
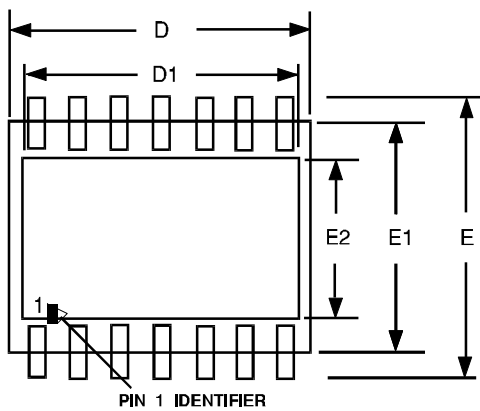

FIGURE 4



DIM	INCHES		MILLIMETER		DIM	INCHES		MILLIMETER	
	MIN	MAX	MIN	MAX		MIN	MAX	MIN	MAX
A	.114	.136	2.90	3.45	E	.410	.435	10.4	11.0
B	.018	.027	.460	.690	E1	.390	.415	9.91	10.5
B1	.047	.056	1.19	1.42	E2	.265	.270	6.73	6.86
B2	.097	.103	2.46	2.62	G1	.285	.315	7.24	8.00
C	.009	.020	0.22	0.51	L	.195	.225	4.95	5.72
D	.690	.715	17.5	18.1	P	.090	.110	2.29	2.79
D1	.666	.680	16.9	17.2	Q	.050	.070	1.27	1.79
					S	.040	.060	1.02	1.52

