

Dual High Voltage, Low Noise EL Lamp Driver

Features

- ❑ 8-pin dual EL driver IC
- ❑ Input control for lamp selection
- ❑ Split supply capability
- ❑ Patented output timing
- ❑ One miniature inductor to power both lamps
- ❑ 150nA shutdown current
- ❑ Wide input voltage range (2.0V to 5.0V)
- ❑ Output voltage regulation
- ❑ No SCR output

Applications

- ❑ Dual display cell phones
- ❑ Keypad and LCD backlighting
- ❑ Dual segment lamps
- ❑ Handheld wireless communication devices

General Description

The Supertex HV832 is a high voltage driver designed for driving two EL lamps with a combined area of 3.5 square inches. The input supply voltage range is from 2.0V to 5.0V. The device is designed to reduce the amount of audible noise emitted by the lamp. The device uses a single inductor and a minimum number of passive components. The nominal regulated output voltage that is applied to the EL lamp is $\pm 90V$.

The HV832 has an internal oscillator, a switching MOSFET, and two high voltage EL lamp drivers. The frequency for the switching MOSFET is set at 51KHz nominal. The EL lamp driver frequency is set by dividing the MOSFET switching frequency by 128. An external inductor is connected between the L_X and V_{DD} pins or V_{IN} for split supply applications. A 0.001 to 0.01 μF , 100V capacitor is connected between C_S and Ground. The EL lamps are connected between EL_1 to Com and EL_2 to Com.

An input control pin is available to select various modes of the device. Each logic pulse applied to the control pin will cause the device to change to the next mode. The sequence for the modes is: (1) EL_1 on only, (2) EL_2 on only, (3) both EL_1 and EL_2 on, and (4) device shuts down. During power up of the device, the mode will default to shut down.

The switching MOSFET charges the external inductor and discharges it into the capacitor at C_S . The voltage at C_S will start to increase. Once the voltage at C_S reaches a nominal value of 90V, the switching MOSFET is turned off to conserve power. The outputs EL_1 to Com and EL_2 to Com are configured as H bridges EL_1/EL_2 and Com are switching in opposite states to achieve 180V across the EL lamp.

Typical Application

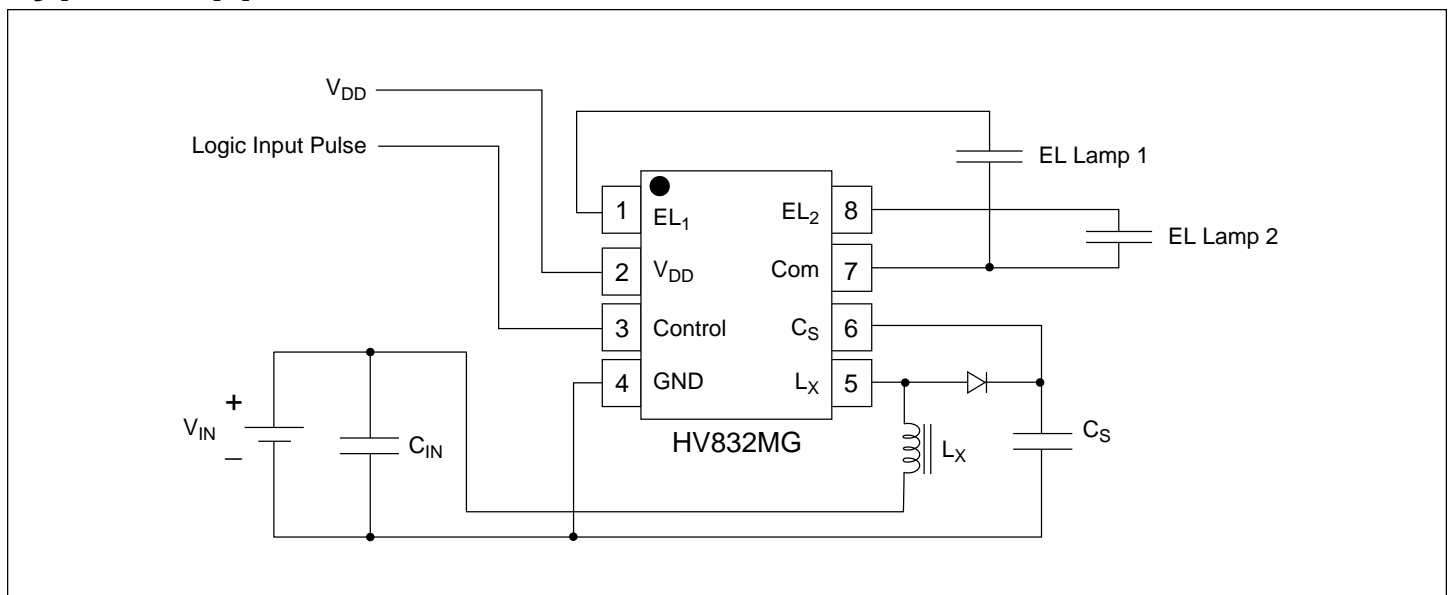

12/13/01

Electrical Characteristics

DC Characteristics (Over recommended operating conditions unless otherwise specified, $T_A = 25^\circ\text{C}$)

| Symbol | Parameter | Min | Typ | Max | Units | Conditions |
|-----------------------|---|------|------|----------|---------------|--|
| $R_{DS(ON)}$ | On-resistance of switching transistor | | | 7.0 | Ω | $I = 100\text{mA}$ |
| V_{CS} | Output regulation voltage | 80 | 90 | 100 | V | $V_{DD} = 2.0\text{V to } 5.0\text{V}$ |
| V_{diff} | differential output voltage across each lamp (EL ₁ to Com, EL ₂ to Com) | 160 | 180 | 200 | V | $V_{DD} = 2.0\text{V to } 5.0\text{V}$ |
| I_{DDQ} | Quiescent V_{DD} supply current | | | 150 | nA | |
| I_{DD} | Input current into V_{DD} pin | | | 150 | μA | $V_{DD} = 2.0\text{V to } 5.0\text{V}$ |
| I_{IN} | Input current including inductor current | | 27 | 32 | mA | $V_{IN} = 3.0\text{V}$. Driving EL1 or EL2. See Figure 1. |
| | | | 38 | 43 | | $V_{IN} = 3.0\text{V}$. Driving both EL1 and EL2. See Figure 1. |
| V_{CS} | Output voltage on V_{CS} | 68 | 78 | 87 | V | $V_{IN} = 3.0\text{V}$. Driving EL1 or EL2. See Figure 1. |
| | | 62 | 70 | 78 | | $V_{IN} = 3.0\text{V}$. Driving both EL1 and EL2, See Figure 1. |
| f_{EL} | V_{diff} output drive frequency | 350 | 400 | 450 | Hz | $V_{IN} = 3.0\text{V}$. See Figure 1. |
| f_{SW} | Switching transistor frequency | 44.8 | 51.2 | 57.6 | KHz | $V_{IN} = 3.0\text{V}$. See Figure 1. |
| $f_{SW\text{ Drift}}$ | Switching transistor frequency Drift | | | +/- 5.0 | KHz | $T_A = -40^\circ\text{C to } +85^\circ\text{C}$ |
| D | Switching transistor duty cycle | 85 | | | % | See Figure 1. |
| I_{IL} | Input logic low current going into the control pin. | | | 0.6 | μA | $V_{DD} = 2.0\text{V to } 5.0\text{V}$. See Figure 1. |
| I_{IH} | Input logic high current going into the control pin. | | | 0.6 | | |
| V_{IL} | Logic input low voltage | 0 | | 0.25 | V | |
| V_{IH} | Logic input high voltage | 1.75 | | V_{DD} | V | |

* The inductor used is a 330uH Murata inductor, max DC resistance of 10 Ohms, part # LQH32CN331.

Recommended Operating Conditions

| Symbol | Parameter | Min | Typ | Max | Units | Conditions |
|----------|-----------------------|-----|-----|-----|------------------|------------|
| V_{DD} | Supply voltage | 2.0 | | 5.0 | V | |
| T_A | Operating temperature | -40 | | 85 | $^\circ\text{C}$ | |

Absolute Maximum Ratings*

| | |
|------------------------------|---|
| Supply voltage, V_{DD} | -0.5V to 7.5V |
| Output voltage, V_{CS} | -0.5V to +120V |
| Operating Temperature Range | -40 $^\circ\text{C}$ to +85 $^\circ\text{C}$ |
| Storage Temperature Range | -65 $^\circ\text{C}$ to +150 $^\circ\text{C}$ |
| 8 Pin MSOP Power Dissipation | 300mW |

* All voltages are referenced to ground.

Ordering Information

| Device | Package Options | |
|--------|-----------------|--------|
| | MSOP-8 | Die |
| HV832 | HV832MG* | HV832X |

* Product supplied on 2500 piece carrier tape reels.

Function Table

| Control Pin | EL ₁ | EL ₂ | Com | IC |
|------------------------------|-----------------|-----------------|------|-----|
| Power up | HI Z | HI Z | HI Z | OFF |
| 1 st pulse L to H | ON | HI Z | ON | ON |
| 2 nd pulse L to H | HI Z | ON | ON | ON |
| 3 rd pulse L to H | ON | ON | ON | ON |
| 4 th pulse L to H | HI Z | HI Z | HI Z | OFF |

Pin Configuration

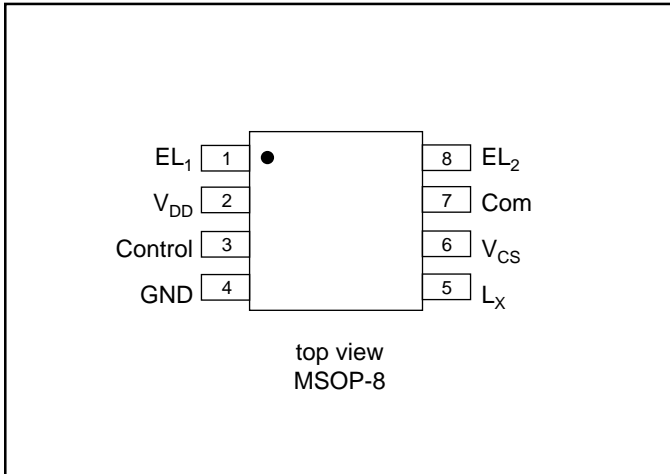

Functional Block Diagram

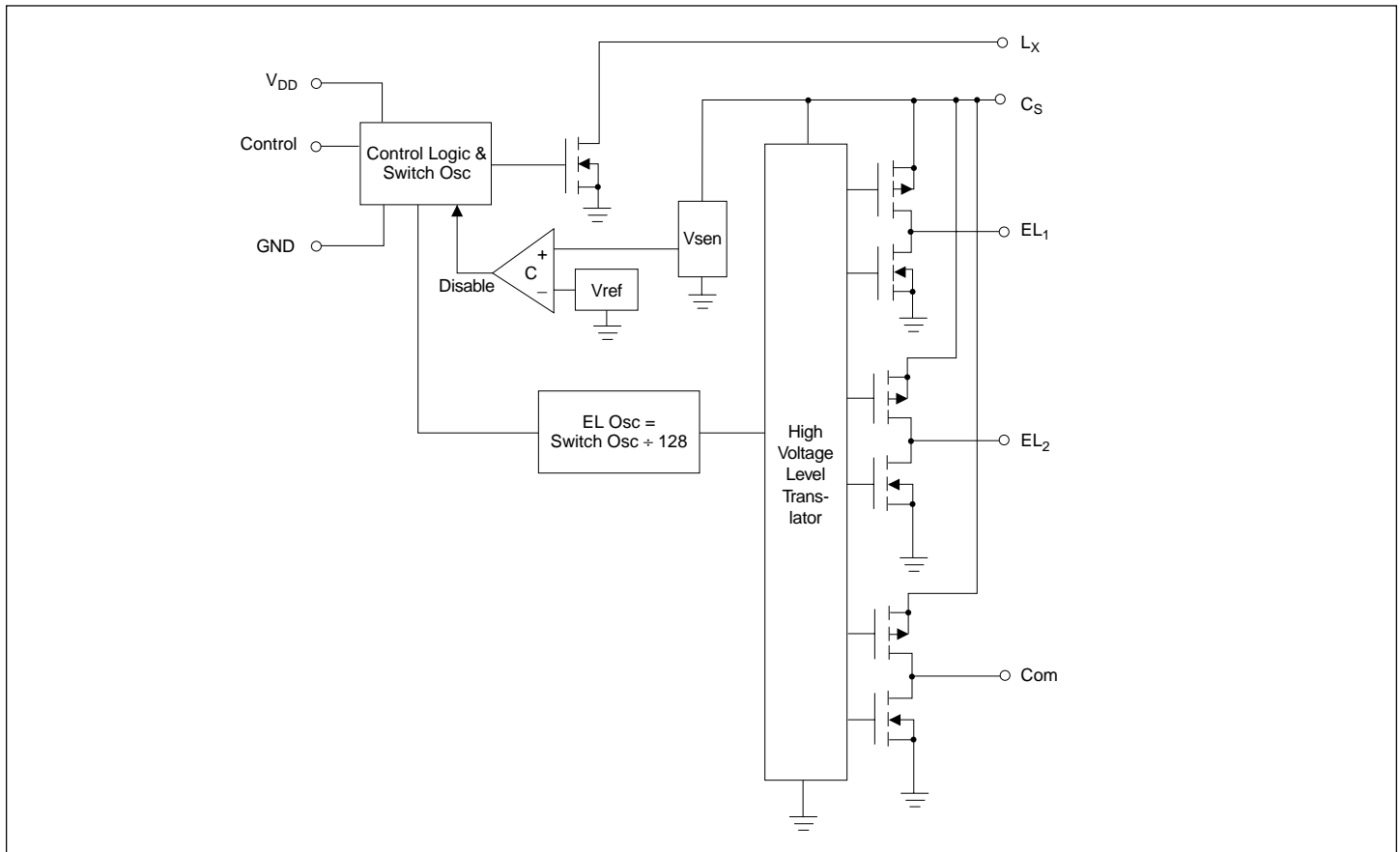
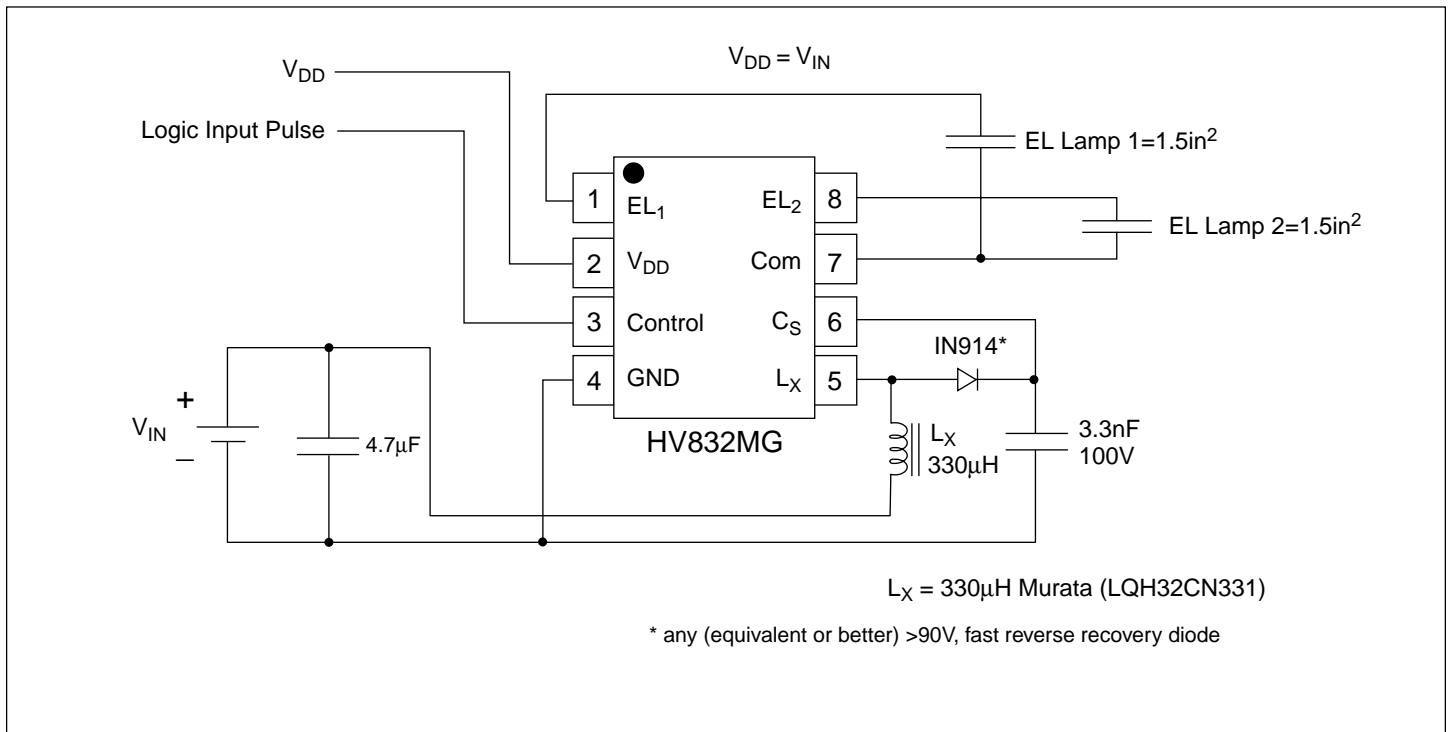
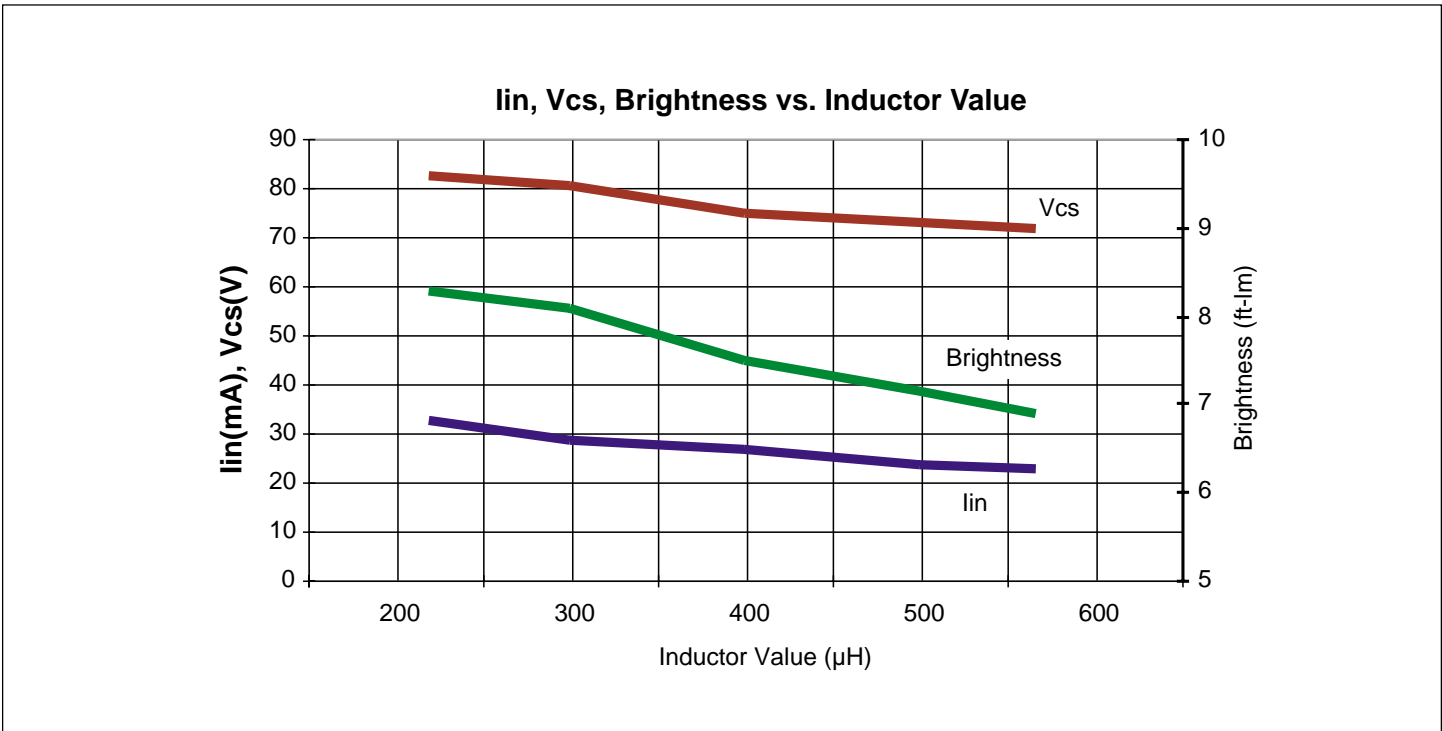
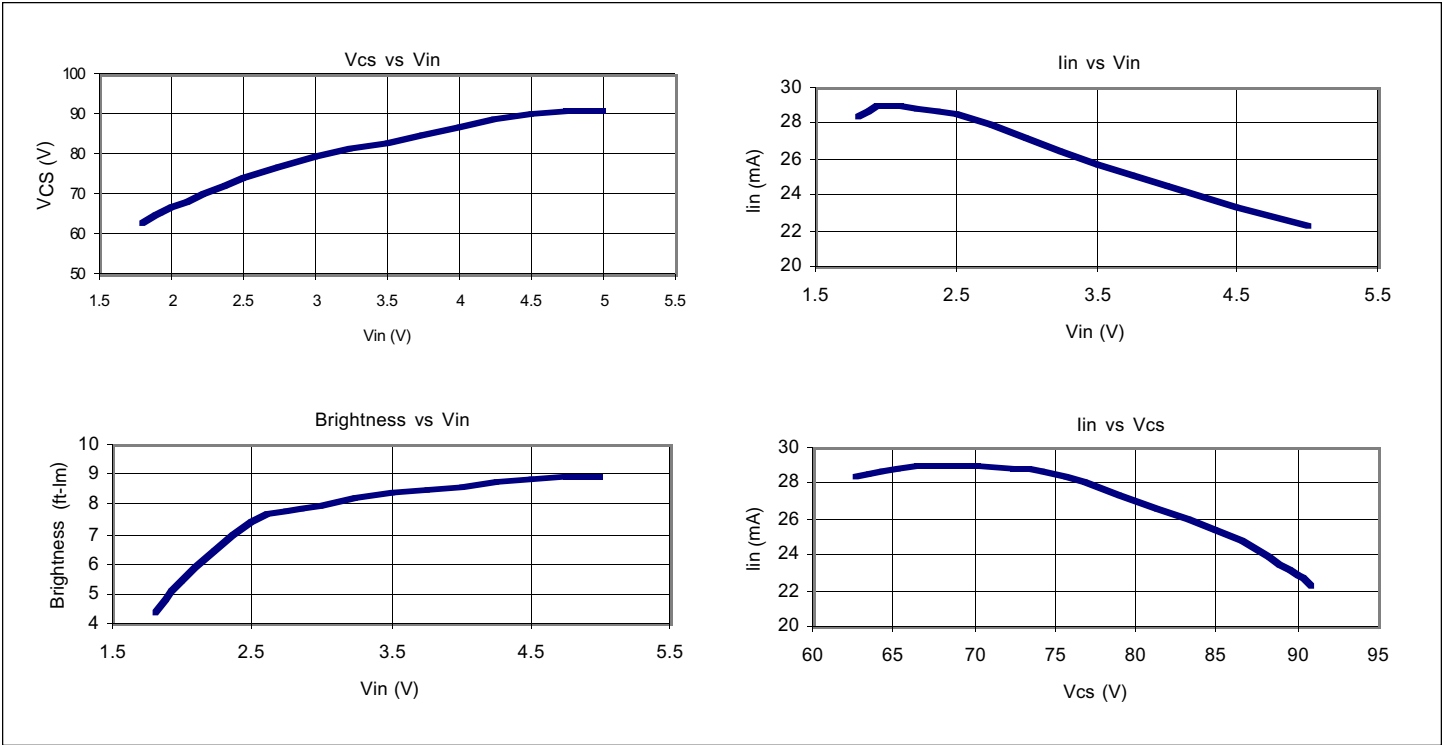

Figure 1: Typical Application Circuit/Test Circuit



| Device | Lamp | V_{DD} | I_{DD} | V_{CS} | f_{EL} | Brightness |
|---------|---|----------|----------|----------|----------|------------|
| HV832MG | EL ₁ or EL ₂ ON | 3.0V | 27mA | 78V | 400Hz | 7.5ft-Im |
| | Both EL ₁ and EL ₂ ON | | 38mA | 70V | | 6.2ft-Im |

**Typical Performance Curves for Figure 1 with one output ON
(EL Lamp=1.5in², V_{DD}=3.0V)**



External Component Description

| External Component | Selection Guide Line |
|--------------------|--|
| Diode | Fast reverse recovery diode, IN914 or equivalent. |
| Cs Capacitor | 0.003 μ F to 0.1 μ F, 100V capacitor to GND is used to store the energy transferred from the inductor. |
| Lx Inductor | The inductor L_x is used to boost the low input voltage by inductive flyback. When the internal switch is on, the inductor is being charged. When the internal switch is off, the charge stored in the inductor will be transferred to the high voltage capacitor C_s . The energy stored in the capacitor is connected to the internal H-bridge and therefore to the EL lamp. In general, smaller value inductors, which can handle more current, are more suitable to drive larger size lamps. |
| Lamp | As the EL lamp size increases, more current will be drawn from the battery to maintain high voltage across the EL lamp. The input power, ($V_{IN} \times I_{IN}$), will also increase. If the input power is greater than the power dissipation of the package (300mW), an external resistor in series with one side of the lamp is recommended to help reduce the package power dissipation. |

Split Supply Configuration

The HV832 can also be used for handheld devices operating from a battery where a regulated voltage is available. This is shown in Figure 2. The regulated voltage can be used to run the internal logic of the HV832. The amount of current necessary to run the internal logic is 150 μ A Max at a V_{DD} of 3.0V. Therefore, the regulated voltage could easily provide the current without being loaded down.

Figure 2: Split Supply

