



TSH70,71,72,73,74,75

WIDE BAND, LOW POWER OPERATIONAL AMPLIFIER WITH STANDBY FUNCTION

- **3V, 5V, ±5V SPECIFICATIONS**
- **3dB-BANDWIDTH : 90MHz**
- **GAIN-BANDWIDTH PRODUCT : 70MHz**
- **SLEW-RATE : 100V/μs**
- **OUTPUT CURRENT : up to 55mA**
- **INPUT SINGLE SUPPLY VOLTAGE**
- **OUTPUT RAIL TO RAIL**
- **SPECIFIED FOR 150Ω LOAD**
- **LOW DISTORTION, THD : 0.1%**
- **SOT23-5, TSSOP and SO PACKAGES**

DESCRIPTION

TSH7x serie offers Single, Dual, Triple and Quad operational amplifiers featuring high video performances with large bandwidth, low distortion and excellent supply voltage rejection.

Running at single supply voltage from 3V to 12V, amplifiers feature large output voltage swing and high output current capability to drive standard 150Ω loads. Low operating voltage makes TSH7x amplifiers ideal for use on portable equipments.

The TSH71, TSH73 and TSH75 also feature some Standby input, each of which allows the op amp to be put into a standby mode with low power consumption and high output impedance. The function allows power saving or signals switching/multiplexing for high speed applications and video applications.

For board space and weight saving, TSH7x series is proposed in SOT23-5, TSSOP and SO packages.

APPLICATION

- Video buffers
- A/D Converters driver
- HiFi applications

PIN CONNECTIONS (top view)

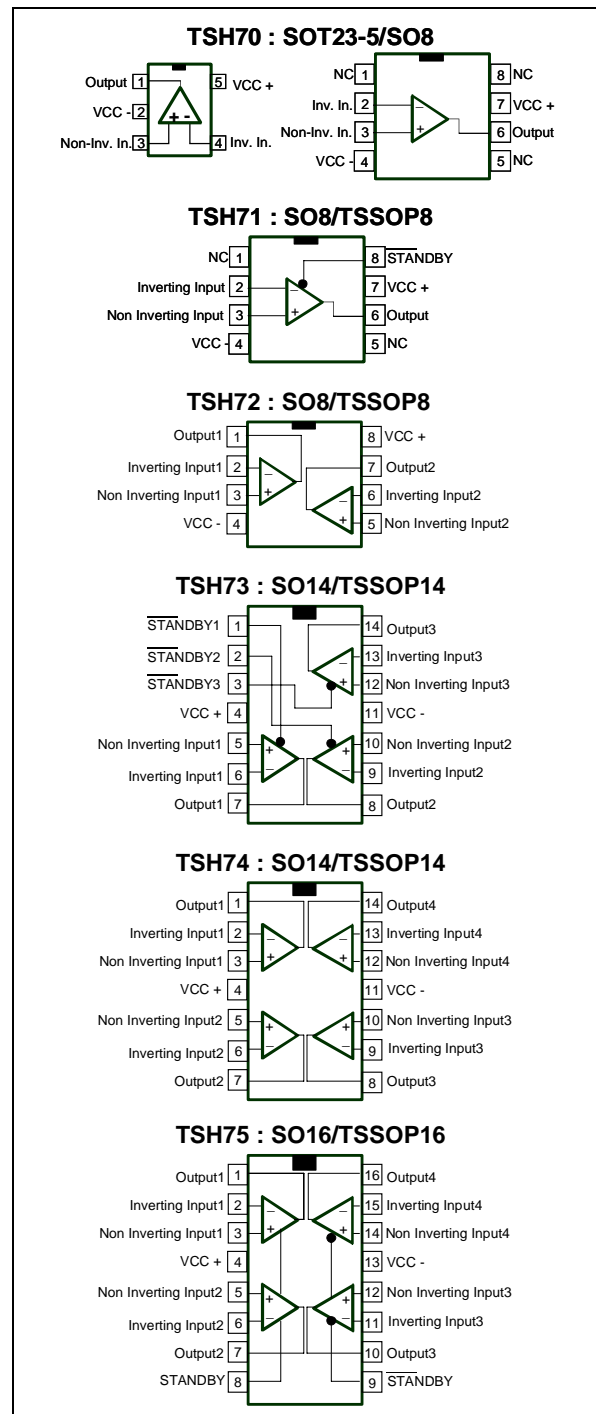

ABSOLUTE MAXIMUM RATINGS

Symbol	Parameter	Value	Unit
V_{CC}	Supply Voltage ¹⁾	14	V
V_{id}	Differential Input Voltage ²⁾	±2	V
V_i	Input Voltage ³⁾	±6	V
T_{oper}	Operating Free Air Temperature Range	0 to +70	°C
T_{stg}	Storage Temperature	-65 to +150	°C
T_j	Maximum Junction Temperature	150	°C
R_{thjc}	Thermal resistance junction to case ⁴⁾	SOT23-5	80
		SO8	28
		SO14	22
		SO16	35
		TSSOP08	37
		TSSOP14	32
		TSSOP16	35
R_{thja}	Thermal resistance junction to ambient area	SOT23-5	250
		SO8	157
		SO14	125
		SO16	110
		TSSOP08	130
		TSSOP14	110
		TSSOP16	110
ESD	HumanBodyModel	2	kV

1. All voltages values, except differential voltage are with respect to network ground terminal
2. Differential voltages are non-inverting input terminal with respect to the inverting terminal
3. The magnitude of input and output must never exceed $V_{CC} + 0.3V$
4. Short-circuits can cause excessive heating

OPERATING CONDITIONS

Symbol	Parameter	Value	Unit
V_{CC}	Supply Voltage	3 to 12	V
V_{IC}	Common Mode Input Voltage Range	V_{CC}^- to $(V_{CC}^+ - 1.1)$	V
Standby		(V_{CC}^-) to (V_{CC}^+)	V

ORDER CODES

Type	Temperature	Package	Marking
TSH70CLT	0°C to 70°C	SOT23-5	K301
TSH70CD		SO8	70C
TSH70CDT		SO8 Tape	70C
TSH71CD		SO8	71C
TSH71CDT		SO8 Tape	71C
TSH71CPT		TSSOP8	71C
TSH72CD		SO8	72C
TSH72CDT		SO8 Tape	72C
TSH72CPT		TSSOP8	72C
TSH73CD		SO14	73C
TSH73CDT		SO14 Tape	73C
TSH73CPT		TSSOP14	73C
TSH74CD		SO14	74C
TSH74CDT		SO14 Tape	74C
TSH74CPT		TSSOP14	74C
TSH75CD		SO16	75C
TSH75CDT		SO16 Tape	75C
TSH75CPT		TSSOP16	75C

C = Temperature range

D = Small Outline Package (SO) - also available in Tape & Reel (DT)

P = Thin Shrink Small Outline Package (TSSOP) - only available in Tape & Reel (PT)

L = Tiny Package (SOT23-5) - only available in Tape & Reel (LT)

ELECTRICAL CHARACTERISTICS
 $V_{CC}^+ = 3V$, $V_{CC}^- = GND$, $V_{ic} = 1.5V$, $T_{amb} = 25^\circ C$ (unless otherwise specified)

Symbol	Parameter	TestCondition	Min.	Typ.	Max.	Unit
$ V_{io} $	Input Offset Voltage	$T_{amb} = 25^\circ C$ $T_{min.} < T_{amb} < T_{max.}$		1.2	10 12	mV
ΔV_{io}	Input Offset Voltage Drift vs. Temperature	$T_{min.} < T_{amb} < T_{max.}$		4		$\mu V/^\circ C$
I_{io}	Input Offset Current	$T_{amb} = 25^\circ C$ $T_{min.} < T_{amb} < T_{max.}$		0.1	3.5 5	μA
I_{ib}	Input Bias Current	$T_{amb} = 25^\circ C$ $T_{min.} < T_{amb} < T_{max.}$		6	15 20	μA
C_{in}	Input Capacitance			0.2		pF
I_{CC}	Supply Current per Operator	$T_{amb} = 25^\circ C$ $T_{min.} < T_{amb} < T_{max.}$		7.2	9.8 11	mA
CMR	Common Mode Rejection Ratio ($\delta V_{ic}/\delta V_{io}$)	$+0.1 < V_{ic} < +1.9V$ & $V_{out}=1.5V$ $T_{amb} = 25^\circ C$ $T_{min.} < T_{amb} < T_{max.}$	65 64	90		dB
SVR	Supply Voltage Rejection Ratio ($\delta V_{CC}/\delta V_{io}$)	$T_{amb} = 25^\circ C$ $T_{min.} < T_{amb} < T_{max.}$	66 65	74		dB
PSR	Power Supply Rejection Ratio ($\delta V_{CC}/\delta V_{out}$)	Positive & Negative Rail		75		dB
A_{vd}	Large Signal Voltage Gain	$R_L=150\Omega$ to 1.5V $V_{out}=1V$ to 2V $T_{amb} = 25^\circ C$ $T_{min.} < T_{amb} < T_{max.}$	70 65	81		dB
I_o	Output Short Circuit Current Source	$T_{amb}=25^\circ C$ $V_{id}=+1, V_{out}$ to 1.5V $V_{id}=-1, V_{out}$ to 1.5V Source Sink $T_{min.} < T_{amb} < T_{max.}$ $V_{id}=+1, V_{out}$ to 1.5V $V_{id}=-1, V_{out}$ to 1.5V Source Sink	30 24 22 23	43 33		mA
V_{oh}	High Level Output Voltage	$T_{amb}=25^\circ C$ $R_L = 150\Omega$ to GND $R_L = 600\Omega$ to GND $R_L = 2k\Omega$ to GND $R_L = 10k\Omega$ to GND $R_L = 150\Omega$ to 1.5V $R_L = 600\Omega$ to 1.5V $R_L = 2k\Omega$ to 1.5V $R_L = 10k\Omega$ to 1.5V $T_{min.} < T_{amb} < T_{max.}$ $R_L = 150\Omega$ to GND $R_L = 150\Omega$ to 1.5V	2.45 2.4 2.6	2.60 2.87 2.91 2.93 2.77 2.90 2.92 2.93		V

TSH70, 71, 72, 73, 74, 75

Symbol	Parameter	TestCondition	Min.	Typ.	Max.	Unit
V_{ol}	Low Level Output Voltage	$T_{amb}=25^{\circ}C$ $R_L = 150\Omega$ to GND $R_L = 600\Omega$ to GND $R_L = 2k\Omega$ to GND $R_L = 10k\Omega$ to GND $R_L = 150\Omega$ to 1.5V $R_L = 600\Omega$ to 1.5V $R_L = 2k\Omega$ to 1.5V $R_L = 10k\Omega$ to 1.5V $T_{min.} < T_{amb} < T_{max.}$ $R_L = 150\Omega$ to GND $R_L = 150\Omega$ to 1.5V		46 52 53 54 140 90 68 57	150 300 200 350	mV
GBP	Gain Bandwidth Product	$F=10MHz$ $A_{VCL}=+11$ $A_{VCL}=-10$		65 55		MHz
Bw	Bandwidth @-3dB	$A_{VCL}=+1$ $R_L=150\Omega$ to 1.5V		87		MHz
SR	Slew Rate	$A_{VCL}=+2$ $R_L=150\Omega // C_L$ to 1.5V $C_L = 5pF$ $C_L = 30pF$	45	80 85		V/ μs
ϕ_m	Phase Margin	$R_L=150\Omega // 30pF$ to 1.5V		40		$^{\circ}$
e_n	Equivalent Input Noise Voltage	$F=100kHz$		11		nV/ \sqrt{Hz}
THD	Total Harmonic Distortion	$A_{VCL}=+2, F=4MHz$ $R_L=150\Omega // 30pF$ to 1.5V $V_{out}=1V_{pp}$ $V_{out}=2V_{pp}$		-61 -54		dB
IM2	Second order intermodulation product	$A_{VCL}=+2, V_{out}=2V_{pp}$ $R_L=150\Omega$ to 1.5V $F_{in1}=180kHz, F_{in2}=280kHz$ spurious measurement @100kHz		-76		dBc
IM3	Third order inter modulation product	$A_{VCL}=+2, V_{out}=2V_{pp}$ $R_L=150\Omega$ to 1.5V $F_{in1}=180kHz, F_{in2}=280kHz$ spurious measurement @400kHz		-68		dBc
ΔG	Differential gain	$A_{VCL}=+2, R_L=150\Omega$ to 1.5V $F=4.5MHz, V_{out}=2V_{pp}$		0.5		%
Df	Differential phase	$A_{VCL}=+2, R_L=150\Omega$ to 1.5V $F=4.5MHz, V_{out}=2V_{pp}$		0.5		$^{\circ}$
Gf	Gain Flatness	$F=DC$ to 6MHz, $A_{VCL}=+2$		0.2		dB
V_{o1}/V_{o2}	Channel Separation	$F=1MHz$ to 10MHz		65		dB

ELECTRICAL CHARACTERISTICS
 $V_{CC}^+ = 5V$, $V_{CC}^- = GND$, $V_{ic} = 2.5V$, $T_{amb} = 25^\circ C$ (unless otherwise specified)

Symbol	Parameter	TestCondition	Min.	Typ.	Max.	Unit
$ V_{io} $	Input Offset Voltage	$T_{amb} = 25^\circ C$ $T_{min.} < T_{amb} < T_{max.}$		1.1	10 12	mV
ΔV_{io}	Input Offset Voltage Drift vs Temperature	$T_{min.} < T_{amb} < T_{max.}$		3		$\mu V/^\circ C$
I_{io}	Input Offset Current	$T_{amb} = 25^\circ C$ $T_{min.} < T_{amb} < T_{max.}$		0.1	3.5 5	μA
I_{ib}	Input Bias Current	$T_{amb} = 25^\circ C$ $T_{min.} < T_{amb} < T_{max.}$		6	15 20	μA
C_{in}	Input Capacitance			0.3		pF
I_{CC}	Supply Current per Operator	$T_{amb} = 25^\circ C$ $T_{min.} < T_{amb} < T_{max.}$		8.2	10.5 11.5	mA
CMR	Common Mode Rejection Ratio ($\delta V_{ic}/\delta V_{io}$)	$+0.1 < V_{ic} < 3.9V$ & $V_{out} = 2.5V$ $T_{amb} = 25^\circ C$ $T_{min.} < T_{amb} < T_{max.}$	72 71	97		dB
SVR	Supply Voltage Rejection Ratio ($\delta V_{CC}/\delta V_{io}$)	$T_{amb} = 25^\circ C$ $T_{min.} < T_{amb} < T_{max.}$	68 67	75		dB
PSR	Power Supply Rejection Ratio ($\delta V_{CC}/\delta V_{out}$)	Positive & Negative Rail		75		dB
A_{vd}	Large Signal Voltage Gain	$R_L = 150\Omega$ to 1.5V $V_{out} = 1V$ to 4V $T_{amb} = 25^\circ C$ $T_{min.} < T_{amb} < T_{max.}$	75 70	84		dB
I_o	Output Short Circuit Current Source	$T_{amb} = 25^\circ C$ $V_{id} = +1, V_{out}$ to 1.5V $V_{id} = -1, V_{out}$ to 1.5V Source Sink $T_{min.} < T_{amb} < T_{max.}$ $V_{id} = +1, V_{out}$ to 1.5V $V_{id} = -1, V_{out}$ to 1.5V Source Sink	35 33 34 32	55 55		mA
V_{oh}	High Level Output Voltage	$T_{amb} = 25^\circ C$ $R_L = 150\Omega$ to GND $R_L = 600\Omega$ to GND $R_L = 2k\Omega$ to GND $R_L = 10k\Omega$ to GND $R_L = 150\Omega$ to 2.5V $R_L = 600\Omega$ to 2.5V $R_L = 2k\Omega$ to 2.5V $R_L = 10k\Omega$ to 2.5V $T_{min.} < T_{amb} < T_{max.}$ $R_L = 150\Omega$ to GND $R_L = 150\Omega$ to 2.5V	4.2 4.5 4.1 4.4	4.36 4.85 4.90 4.93 4.66 4.90 4.92 4.93		V

TSH70, 71, 72, 73, 74, 75

Symbol	Parameter	TestCondition	Min.	Typ.	Max.	Unit
V _{ol}	Low Level Output Voltage	T _{amb} =25°C R _L = 150Ω to GND R _L = 600Ω to GND R _L = 2kΩ to GND R _L = 10kΩ to GND		48 54 55 56	150	mV
		R _L = 150Ω to 2.5V R _L = 600Ω to 2.5V R _L = 2kΩ to 2.5V R _L = 10kΩ to 2.5V		220 105 76 61	400	
		T _{min.} < T _{amb} < T _{max.} R _L = 150Ω to GND R _L = 150Ω to 2.5V			200 450	
GBP	Gain Bandwidth Product	F=10MHz A _{VCL} =+11 A _{VCL} =-10		65 55		MHz
Bw	Bandwidth @-3dB	A _{VCL} =+1 R _L =150Ω to 2.5V		87		MHz
SR	Slew Rate	A _{VCL} =+2 R _L =150Ω // C _L to 2.5V C _L = 5pF C _L = 30pF	60	104 105		V/μs
φ _m	Phase Margin	R _L =150Ω // 30pF to 2.5V		40		°
e _n	Equivalent Input Noise Voltage	F=100kHz		11		nV/√Hz
THD	Total Harmonic Distortion	A _{VCL} =+2, F=4MHz R _L =150Ω // 30pF to 2.5V V _{out} =1Vpp V _{out} =2Vpp		-61 -54		dB
IM2	Second order intermodulation product	A _{VCL} =+2, V _{out} =2Vpp R _L =150Ω to 2.5V Fin1=180kHz, Fin2=280kHz spurious measurement @100kHz		-76		dBc
IM3	Third order inter modulation product	A _{VCL} =+2, V _{out} =2Vpp R _L =150Ω to 2.5V Fin1=180kHz, Fin2=280kHz spurious measurement @400kHz		-68		dBc
ΔG	Differential gain	A _{VCL} =+2, R _L =150Ω to 2.5V F=4.5MHz, V _{out} =2Vpp		0.5		%
Df	Differential phase	A _{VCL} =+2, R _L =150Ω to 2.5V F=4.5MHz, V _{out} =2Vpp		0.5		°
Gf	Gain Flatness	F=DC to 6MHz, A _{VCL} =+2		0.2		dB
V _{o1} /V _{o2}	Channel Separation	F=1MHz to 10MHz		65		dB

ELECTRICAL CHARACTERISTICS $V_{CC}^+ = 5V$, $V_{CC}^- = -5V$, $V_{ic} = GND$, $T_{amb} = 25^\circ C$ (unless otherwise specified)

Symbol	Parameter	Test Condition	Min.	Typ.	Max.	Unit
$ V_{io} $	Input Offset Voltage	$T_{amb} = 25^\circ C$ $T_{min.} < T_{amb} < T_{max.}$		0.8	10 12	mV
ΔV_{io}	Input Offset Voltage Drift vs Temperature	$T_{min.} < T_{amb} < T_{max.}$		2		$\mu V/^\circ C$
I_{io}	Input Offset Current	$T_{amb} = 25^\circ C$ $T_{min.} < T_{amb} < T_{max.}$		0.1	3.5 5	μA
I_{ib}	Input Bias Current	$T_{amb} = 25^\circ C$ $T_{min.} < T_{amb} < T_{max.}$		6	15 20	μA
C_{in}	Input Capacitance			0.7		pF
I_{CC}	Supply Current per Operator	$T_{amb} = 25^\circ C$ $T_{min.} < T_{amb} < T_{max.}$		9.8	12.3 13.4	mA
CMR	Common Mode Rejection Ratio ($\delta V_{ic}/\delta V_{io}$)	$-4.9 < V_{ic} < 3.9V$ & $V_{out} = GND$ $T_{amb} = 25^\circ C$ $T_{min.} < T_{amb} < T_{max.}$	81 80	106		dB
SVR	Supply Voltage Rejection Ratio ($\delta V_{CC}/\delta V_{io}$)	$T_{amb} = 25^\circ C$ $T_{min.} < T_{amb} < T_{max.}$	71 70	77		dB
PSR	Power Supply Rejection Ratio ($\delta V_{CC}/\delta V_{out}$)	Positive & Negative Rail		75		dB
A_{vd}	Large Signal Voltage Gain	$R_L = 150\Omega$ to GND $V_{out} = -4$ to $+4$ $T_{amb} = 25^\circ C$ $T_{min.} < T_{amb} < T_{max.}$	75 70	86		dB
I_o	Output Short Circuit Current Source	$T_{amb} = 25^\circ C$ $V_{id} = +1$, V_{out} to 1.5V $V_{id} = -1$, V_{out} to 1.5V Source Sink $T_{min.} < T_{amb} < T_{max.}$ $V_{id} = +1$, V_{out} to 1.5V $V_{id} = -1$, V_{out} to 1.5V Source Sink	35 30 34 29	55 55		mA
V_{oh}	High Level Output Voltage	$T_{amb} = 25^\circ C$ $R_L = 150\Omega$ to GND $R_L = 600\Omega$ to GND $R_L = 2k\Omega$ to GND $R_L = 10k\Omega$ to GND $T_{min.} < T_{amb} < T_{max.}$ $R_L = 150\Omega$ to GND	4.2 4.1	4.36 4.85 4.9 4.93		V
V_{ol}	Low Level Output Voltage	$T_{amb} = 25^\circ C$ $R_L = 150\Omega$ to GND $R_L = 600\Omega$ to GND $R_L = 2k\Omega$ to GND $R_L = 10k\Omega$ to GND $T_{min.} < T_{amb} < T_{max.}$ $R_L = 150\Omega$ to GND		-4.63 -4.86 -4.9 -4.93	-4.4 -4.3	mV
GBP	Gain Bandwidth Product	$F = 10MHz$ $A_{VCL} = +11$ $A_{VCL} = -10$		65 55		MHz
Bw	Bandwidth @-3dB	$A_{VCL} = +1$ $R_L = 150\Omega // 30pF$ to GND		100		MHz

TSH70, 71, 72, 73, 74, 75

Symbol	Parameter	Test Condition	Min.	Typ.	Max.	Unit
SR	Slew Rate	$A_{VCL}=+2$ $R_L=150\Omega // C_L$ to GND $C_L = 5pF$ $C_L = 30pF$	68	117 118		V/ μs
ϕ_m	Phase Margin	$R_L=150\Omega$ to gnd		40		$^\circ$
en	Equivalent Input Noise Voltage	F=100kHz		11		nV/ \sqrt{Hz}
THD	Total Harmonic Distortion	$A_{VCL}=+2$, F=4MHz $R_L=150\Omega // 30pF$ to gnd $V_{out}=1V_{pp}$ $V_{out}=2V_{pp}$		-61 -54		dB
IM2	Second order intermodulation product	$A_{VCL}=+2$, $V_{out}=2V_{pp}$ $R_L=150\Omega$ to gnd Fin1=180kHz, Fin2=280KHz spurious measurement @100kHz		-76		dBc
IM3	Third order intermodulation product	$A_{VCL}=+2$, $V_{out}=2V_{pp}$ $R_L=150\Omega$ to gnd Fin1=180kHz, Fin2=280KHz spurious measurement @400kHz		-68		dBc
ΔG	Differential gain	$A_{VCL}=+2$, $R_L=150\Omega$ to gnd F=4.5MHz, $V_{out}=2V_{pp}$		0.5		%
Df	Differential phase	$A_{VCL}=+2$, $R_L=150\Omega$ to gnd F=4.5MHz, $V_{out}=2V_{pp}$		0.5		$^\circ$
Gf	Gain Flatness	F=DC to 6MHz, $A_{VCL}=+2$		0.2		dB
V _{o1} /V _{o2}	Channel Separation	F=1MHz to 10MHz		65		dB

STANDBY MODE V_{CC}^+ , V_{CC}^- , $T_{amb} = 25^\circ\text{C}$ (unless otherwise specified)

Symbol	Parameter	Test Condition	Min.	Typ.	Max.	Unit
V_{low}	Standby Low Level		V_{CC}^-		$(V_{CC}^- + 0.8)$	V
V_{high}	Standby High Level		$(V_{CC}^- + 2)$		(V_{CC}^+)	V
$I_{CC\ SBY}$	Current Consumption per Operator when STANDBY is Active	pin 8 (TSH71) to V_{CC}^- pin 1,2 or 3 (TSH73) to V_{CC}^- pin 8 (TSH75) to V_{CC}^+ pin 9 (TSH75) to V_{CC}^-		20	55	μA
Z_{out}	Output Impedance (R_{out}/C_{out})	R_{out} C_{out}		10 17		$\text{M}\Omega$ pF
T_{on}	Time from Standby Mode to Active Mode			2		μs
T_{off}	Time from Active Mode to Standby Mode	Down to $I_{CC\ SBY} = 10\mu\text{A}$		10		μs

TSH71 STANDBY CONTROL pin 8 ($\overline{\text{SBY}}$)			OPERATOR STATUS		
V_{low}			Standby		
V_{high}			Active		

TSH73 STANDBY CONTROL			OPERATOR STATUS		
pin 1 ($\overline{\text{SBY}}$ OP1)	pin 2 ($\overline{\text{SBY}}$ OP2)	pin 3 ($\overline{\text{SBY}}$ OP3)	OP1	OP1	OP3
V_{low}	x	x	Standby	x	x
V_{high}	x	x	Active	x	x
x	V_{low}	x	x	Standby	x
x	V_{high}		x	Active	x
x	x	V_{low}	x	x	Standby
x	x	V_{high}	x	x	Active

TSH75 STANDBY CONTROL		OPERATOR STATUS			
pin 8 (SBY OP2)	pin 9 ($\overline{\text{SBY}}$ OP3)	OP1	OP2	OP3	OP4
V_{high}	V_{low}	Active	Standby	Standby	Active
V_{high}	V_{high}	Active	Standby	Active	Active
V_{low}	V_{low}	Active	Active	Standby	Active
V_{low}	V_{high}	Active	Active	Active	Active

Closed Loop Gain and Phase vs. Frequency
 Gain=+2, $V_{cc} = \pm 1.5V$, $R_L = 150\Omega$, $T_{amb} = 25^\circ C$

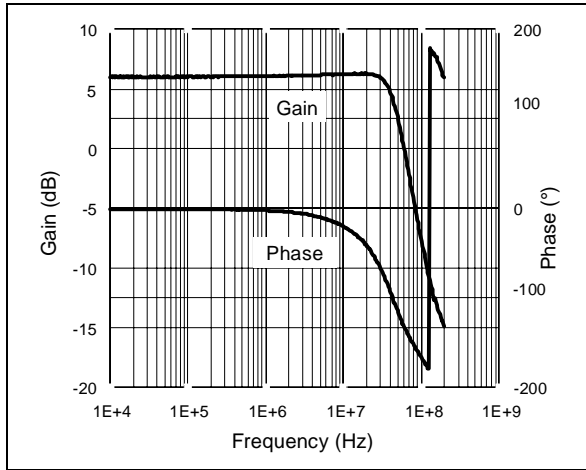

Overshoot function of output capacitance
 Gain=+2, $V_{cc} = \pm 1.5V$, $T_{amb} = 25^\circ C$

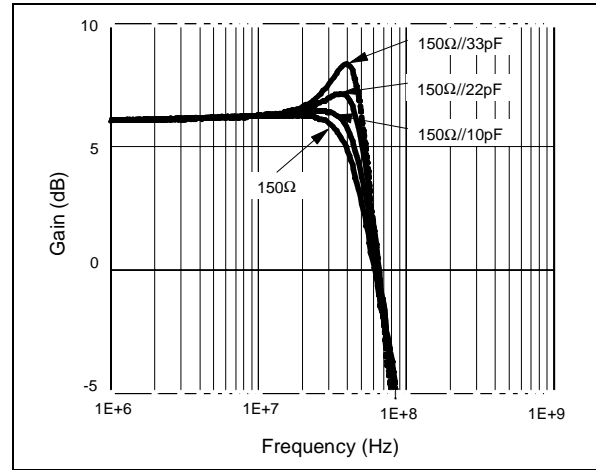

Closed Loop Gain and Phase vs. Frequency
 Gain=-10, $V_{cc} = \pm 1.5V$, $R_L = 150\Omega$, $T_{amb} = 25^\circ C$

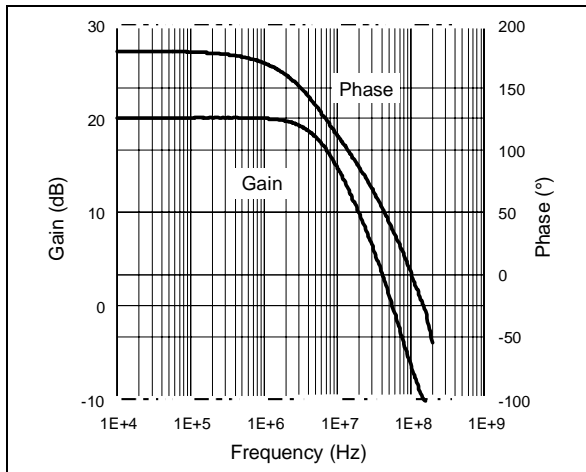

Closed Loop Gain and Phase vs. Frequency
 Gain=+11, $V_{cc} = \pm 1.5V$, $R_L = 150\Omega$, $T_{amb} = 25^\circ C$

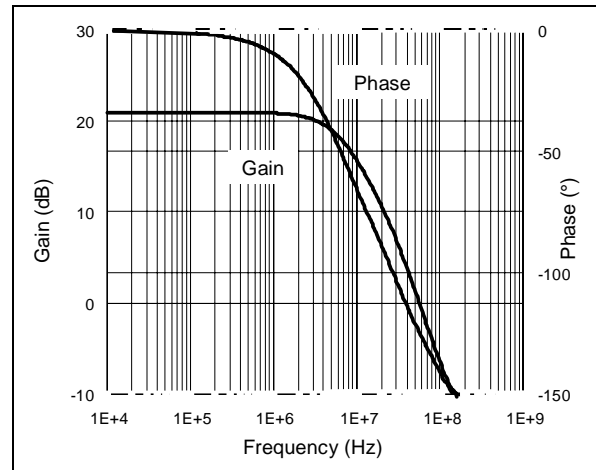

Large Signal Measurement - Positive Slew Rate
 Gain=2, $V_{cc} = \pm 1.5V$, $Z_L = 150\Omega // 5.6pF$, $V_{in} = 400mV_{pk}$

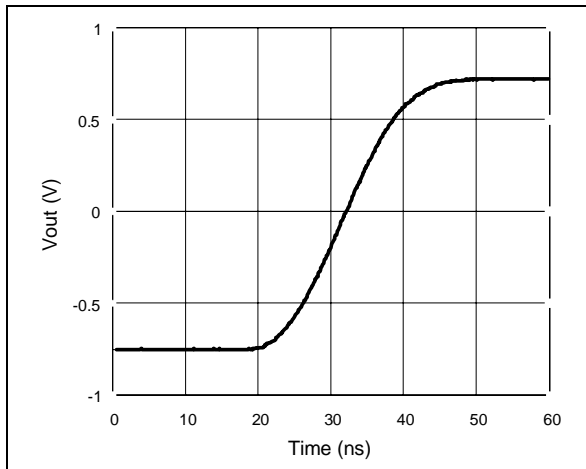

Large Signal Measurement - Negative Slew Rate
 Gain=2, $V_{cc} = \pm 1.5V$, $Z_L = 150\Omega // 5.6pF$, $V_{in} = 400mV_{pk}$

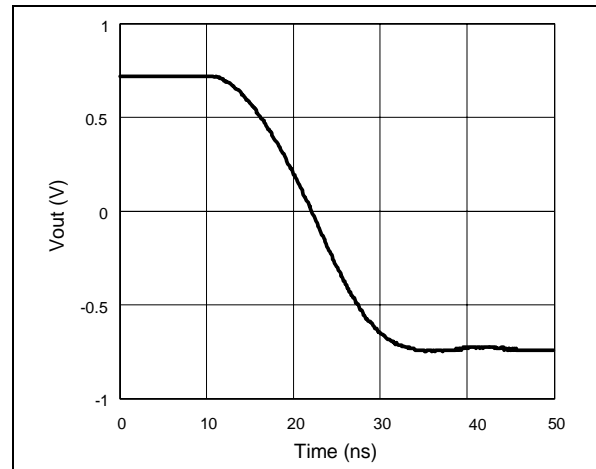

Small Signal Measurement - Rise Time
Gain=2, Vcc=±1.5V, ZL=150Ω, Vin=400mVpk

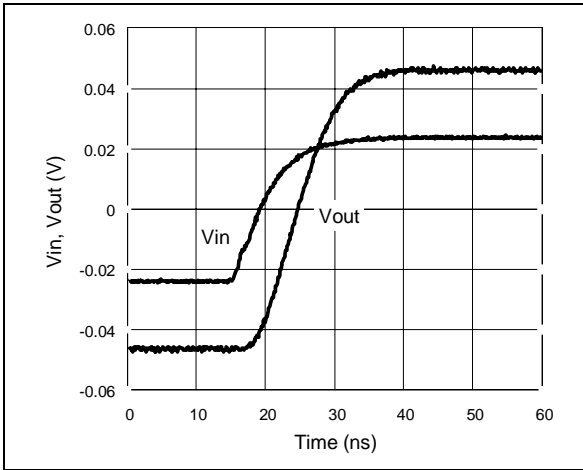

Small Signal Measurement - Fall Time
Gain=2, Vcc=±1.5V, ZL=150Ω, Vin=400mVpk

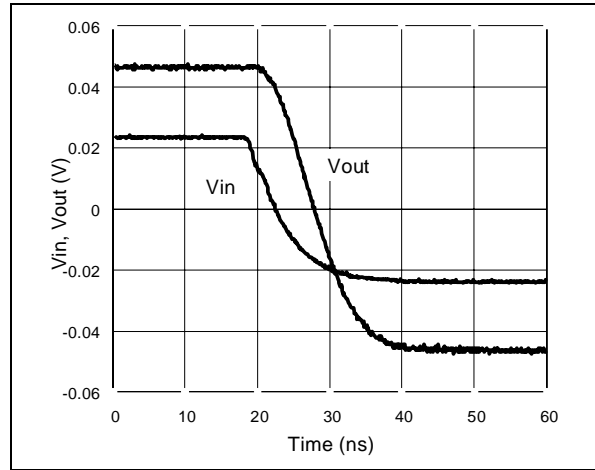

Channel separation (Xtalk) vs frequency
Measurement configuration : $Xtalk=20\log(V0/V1)$

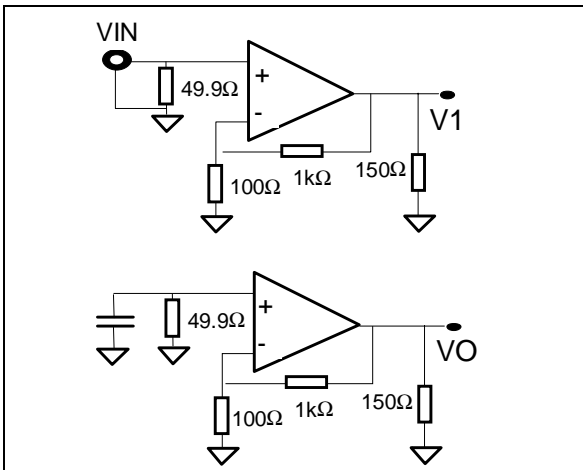

Channel separation (Xtalk) vs frequency
Gain=+11, Vcc=±1.5V, ZL=150Ω//27pF

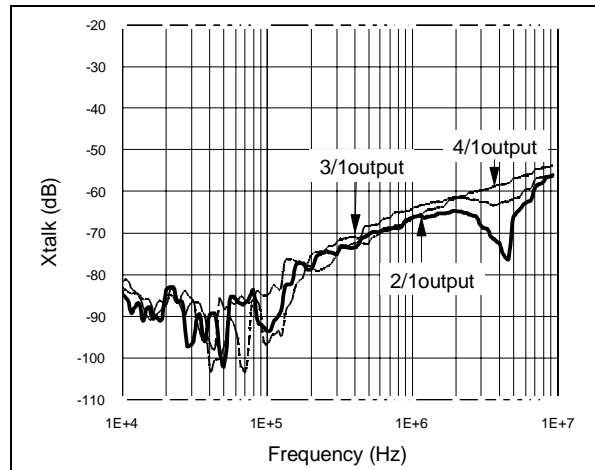

Equivalent Noise Voltage
Gain=100, Vcc=±1.5V, No load

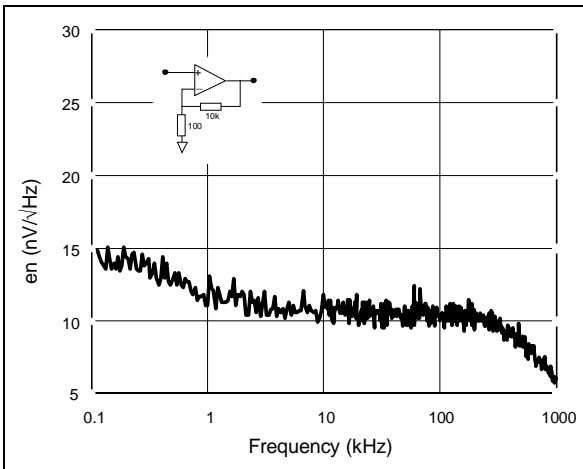

Maximum Output Swing
Gain=11, Vcc=±5V, RL=150Ω

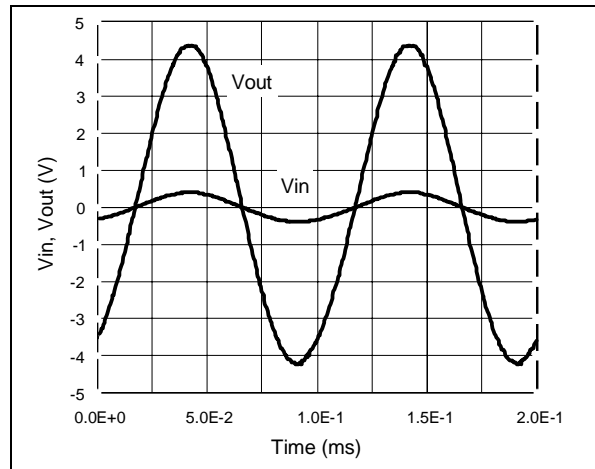

Standby Mode - Ton, Toff

V_{cc}= ±1.5V, Open Loop

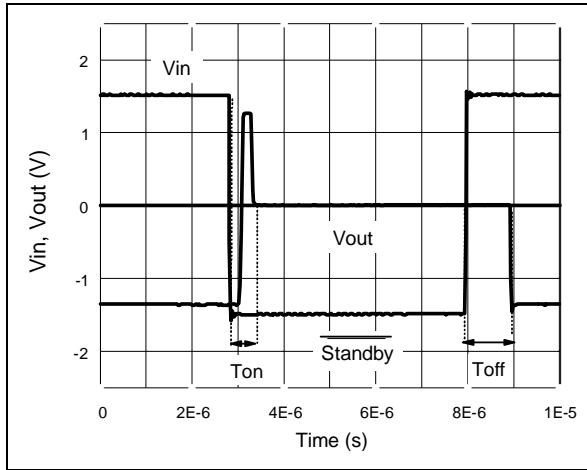

Group Delay

Gain=2, V_{cc}=±1.5V, Z_L=150Ω//27pF, T_{amb} = 25°C

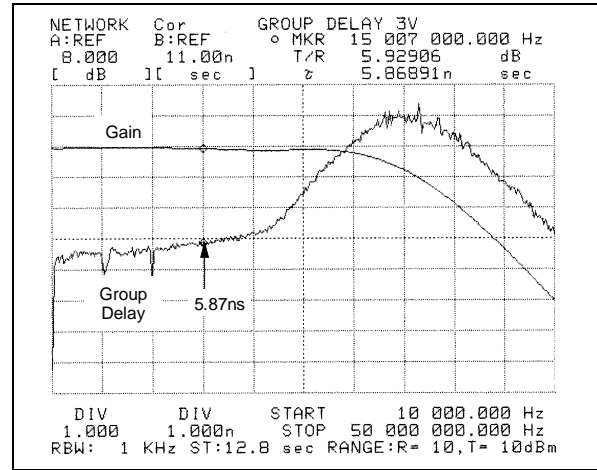

Intermodulation products

The IFR2026 synthesizer generates a two tones signal (F₁=180kHz, F₂=280kHz); each tone having the same amplitude level. The HP3585 spectrum analyzer measures the intermodulation products function of the output voltage. The generator and the spectrum analyzer are phase locked for precision considerations.

Third Order Intermodulation

Gain=2, V_{cc}=±1.5V, Z_L=150Ω//27pF, T_{amb} = 25°C

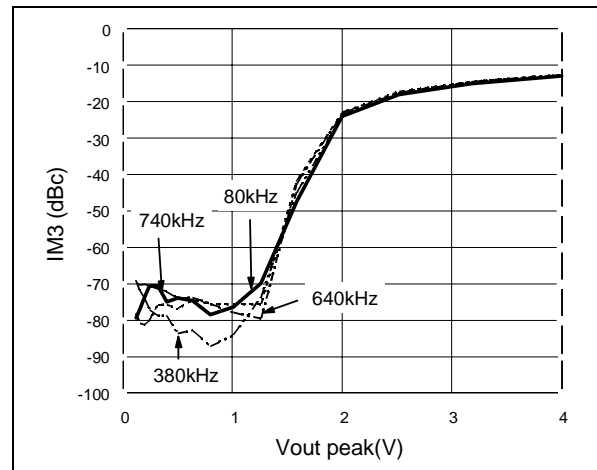

Closed Loop Gain and Phase vs. Frequency
Gain=+2, $V_{cc} = \pm 2.5V$, $R_L = 150\Omega$, $T_{amb} = 25^\circ C$

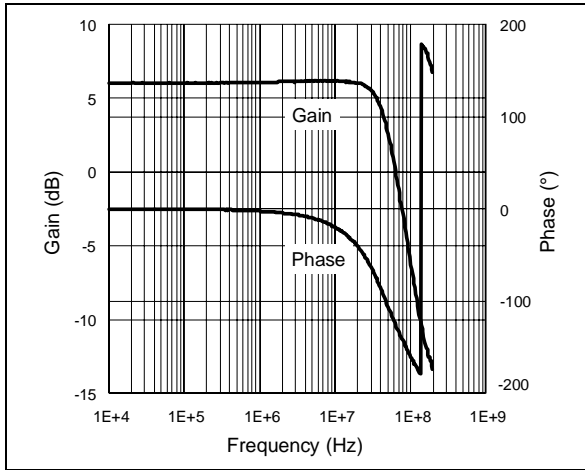

Overshoot function of output capacitance
Gain=+2, $V_{cc} = \pm 2.5V$, $T_{amb} = 25^\circ C$

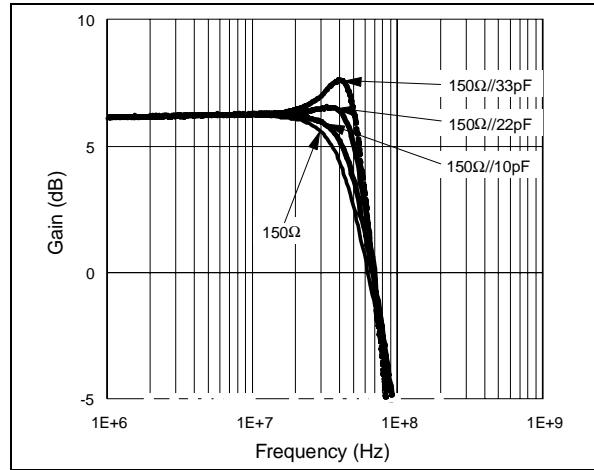

Closed Loop Gain and Phase vs. Frequency
Gain=-10, $V_{cc} = \pm 2.5V$, $R_L = 150\Omega$, $T_{amb} = 25^\circ C$

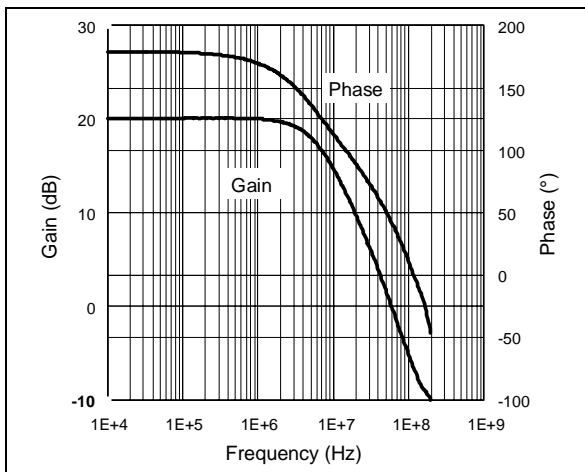

Closed Loop Gain and Phase vs. Frequency
Gain=+11, $V_{cc} = \pm 2.5V$, $R_L = 150\Omega$, $T_{amb} = 25^\circ C$

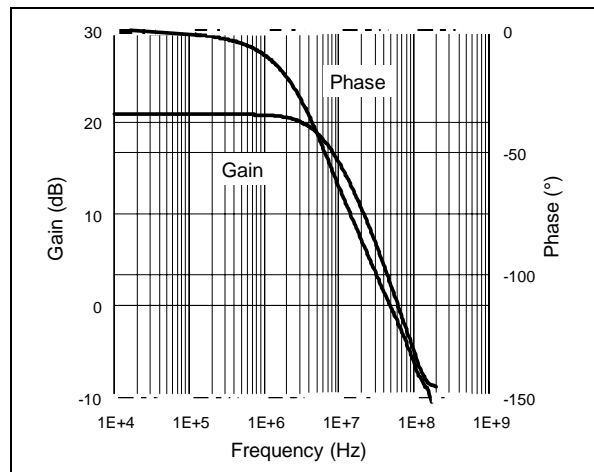

Large Signal Measurement - Positive Slew Rate
Gain=2, $V_{cc} = \pm 2.5V$, $Z_L = 150\Omega / 5.6pF$, $V_{in} = 400mV_{pk}$

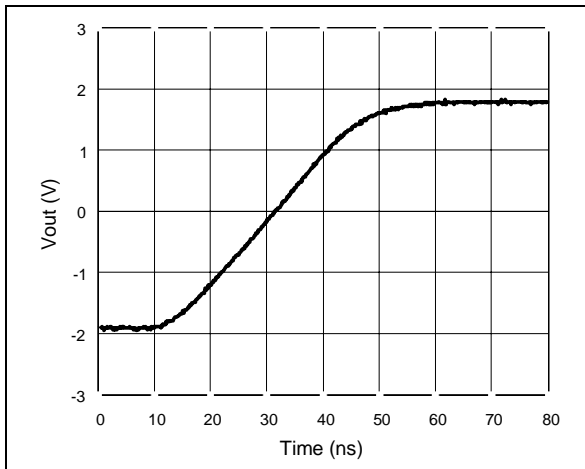

Large Signal Measurement - Negative Slew Rate
Gain=2, $V_{cc} = \pm 2.5V$, $Z_L = 150\Omega / 5.6pF$, $V_{in} = 400mV_{pk}$

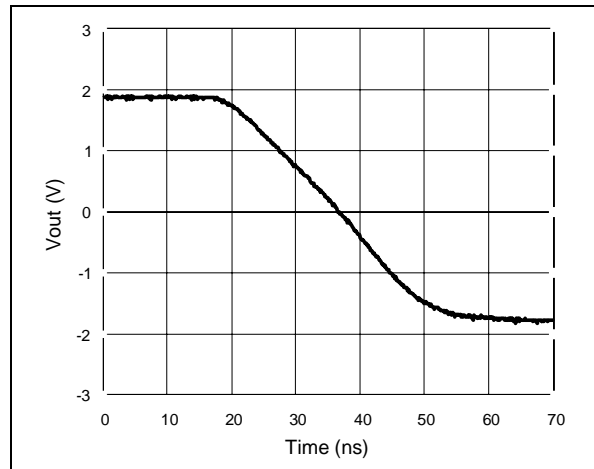

Small Signal Measurement - Rise Time
Gain=2, Vcc=±2.5V, Zl=150Ω, Vin=400mVpk

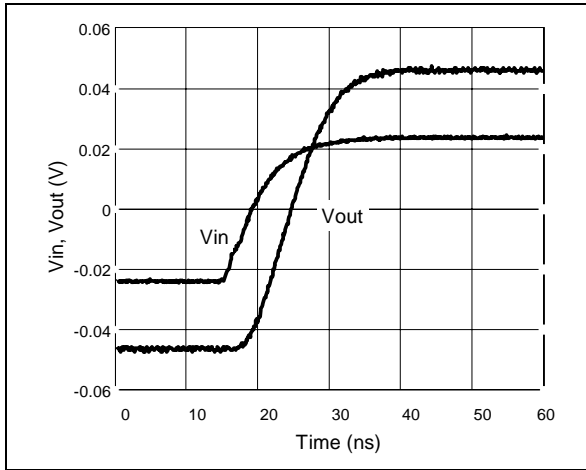

Small Signal Measurement - Fall Time
Gain=2, Vcc=±2.5V, Zl=150Ω, Vin=400mVpk

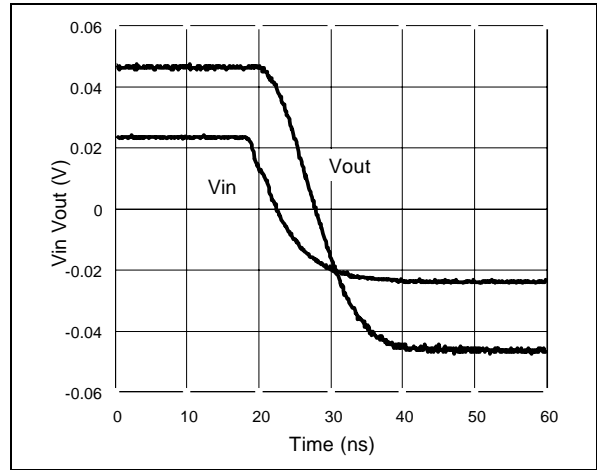

Channel separation (Xtalk) vs frequency
Measurement configuration : $Xtalk=20\log(V0/V1)$

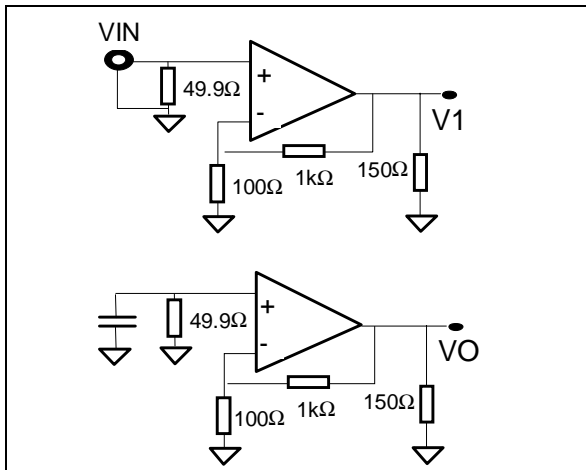

Channel separation (Xtalk) vs frequency
Gain=+11, Vcc=±2.5V, ZL=150Ω//27pF

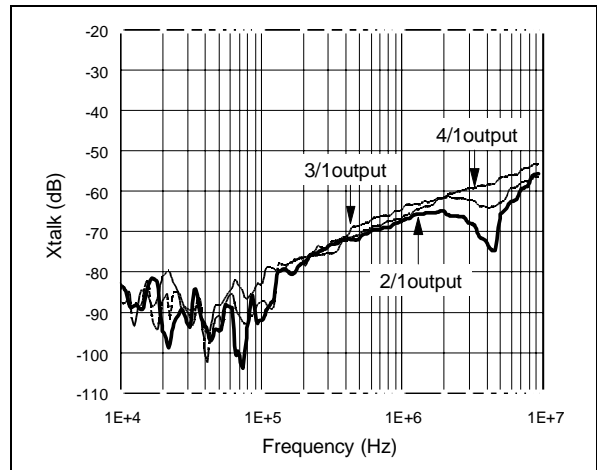

Equivalent Noise Voltage
Gain=100, Vcc=±2.5V, No load

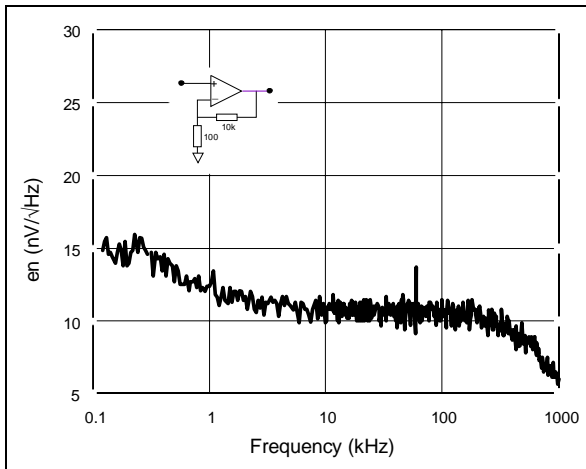

Maximum Output Swing
Gain=11, Vcc=±2.5V, RL=150Ω

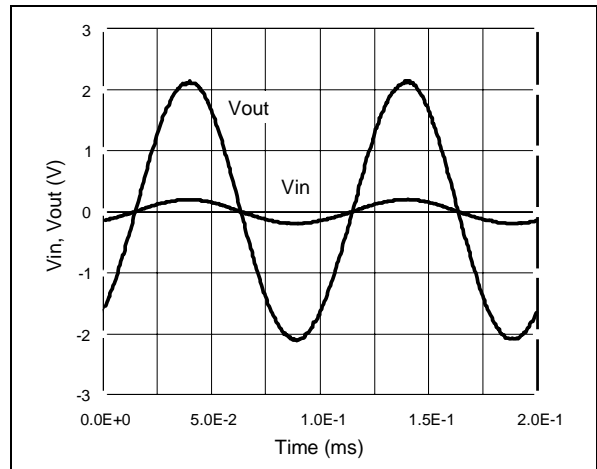

Standby Mode - Ton, Toff

Vcc= ±2.5V, Open Loop

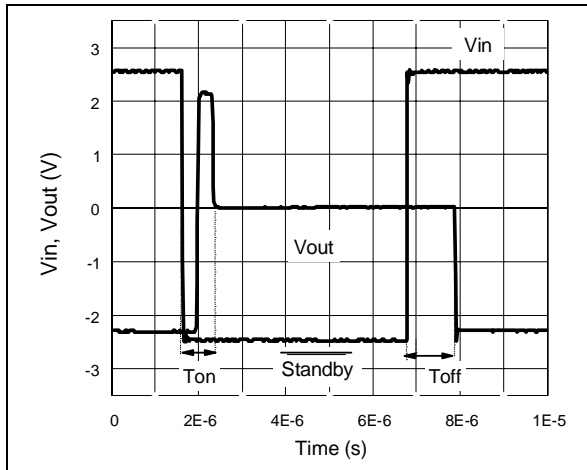

Group Delay

Gain=2, Vcc= ±2.5V, ZL=150Ω//27pF, T_{amb} = 25°C

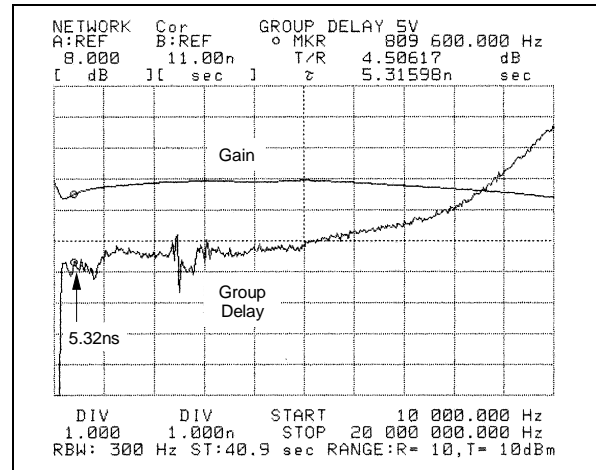

Intermodulation products

The IFR2026 synthesizer generates a two tones signal (F1=180kHz, F2=280kHz); each tone having the same amplitude level.

The HP3585 spectrum analyzer measures the intermodulation products function of the output voltage. The generator and the spectrum analyzer are phase locked for precision considerations.

Third Order Intermodulation

Gain=2, Vcc= ±2.5V, ZL=150Ω//27pF, T_{amb} = 25°C

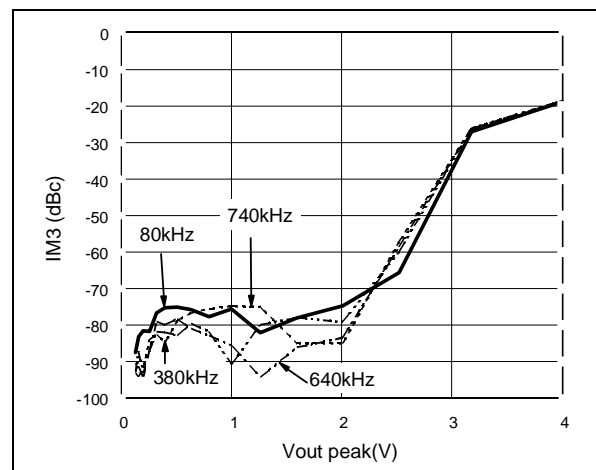

Closed Loop Gain and Phase vs. Frequency
 Gain=+2, $V_{cc} = \pm 5V$, $R_L = 150\Omega$, $T_{amb} = 25^\circ C$

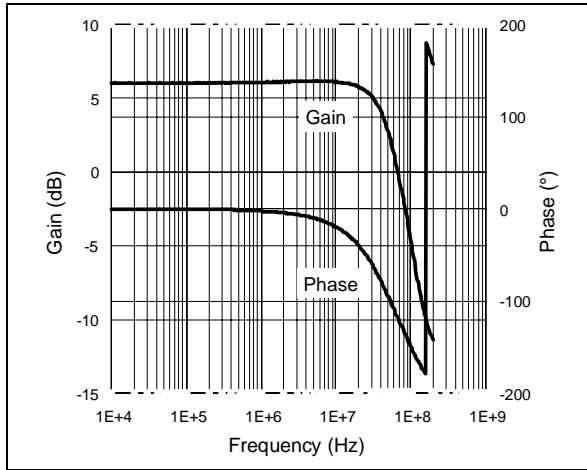

Overshoot function of output capacitance
 Gain=+2, $V_{cc} = \pm 5V$, $T_{amb} = 25^\circ C$

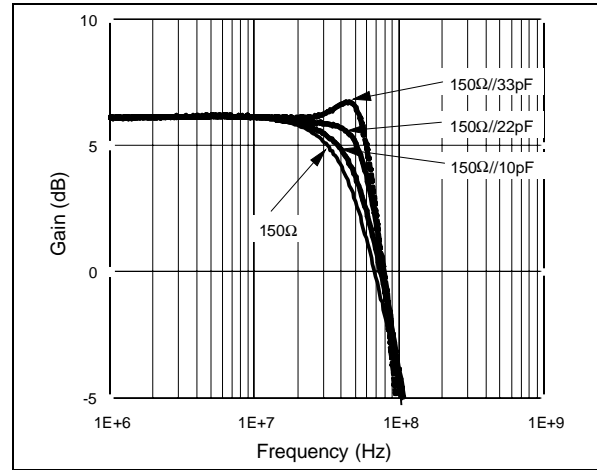

Closed Loop Gain and Phase vs. Frequency
 Gain=-10, $V_{cc} = \pm 5V$, $R_L = 150\Omega$, $T_{amb} = 25^\circ C$

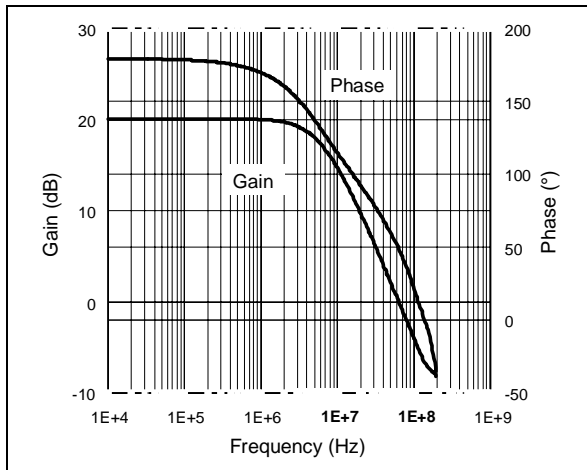

Closed Loop Gain and Phase vs. Frequency
 Gain=+11, $V_{cc} = \pm 5V$, $R_L = 150\Omega$, $T_{amb} = 25^\circ C$

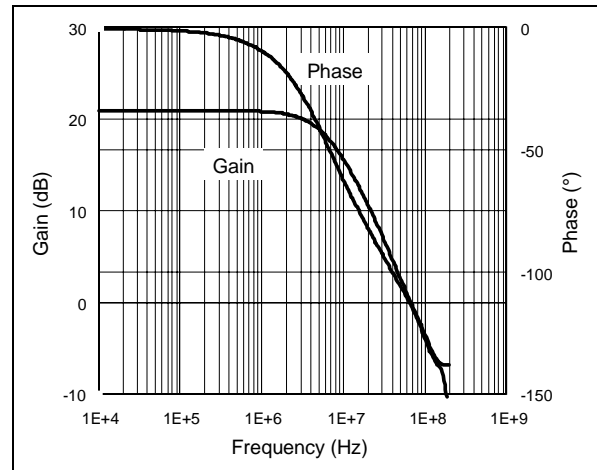

Large Signal Measurement - Positive Slew Rate
 Gain=2, $V_{cc} = \pm 5V$, $Z_L = 150\Omega // 5.6pF$, $V_{in} = 400mV_{pk}$

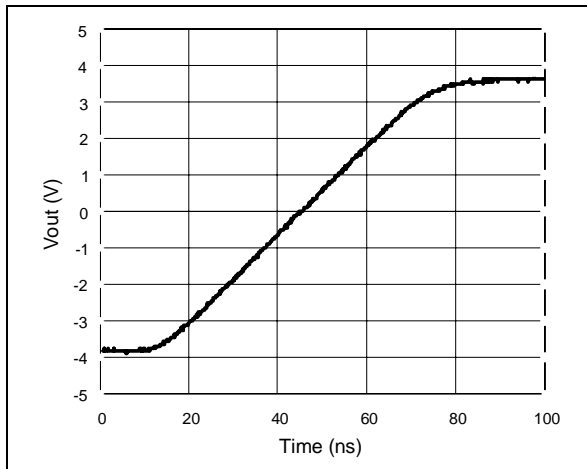

Large Signal Measurement - Negative Slew Rate
 Gain=2, $V_{cc} = \pm 5V$, $Z_L = 150\Omega // 5.6pF$, $V_{in} = 400mV_{pk}$

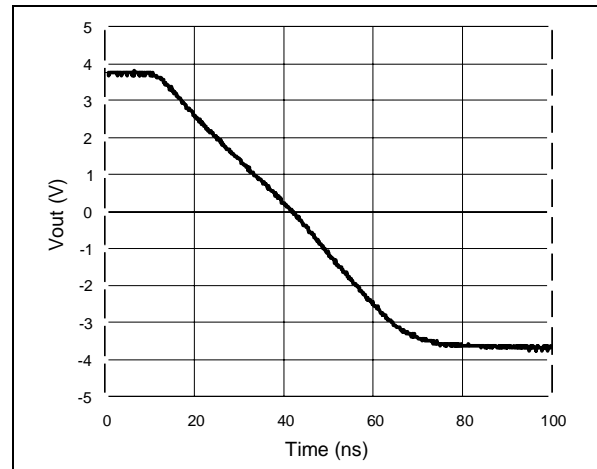

Small Signal Measurement - Rise Time
Gain=2, Vcc=±5V, ZL=150Ω, Vin=400mVpk

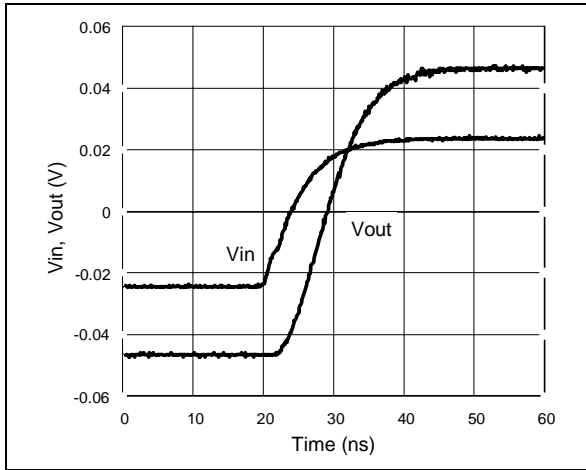

Small Signal Measurement - Fall Time
Gain=2, Vcc=±5V, ZL=150Ω, Vin=400mVpk

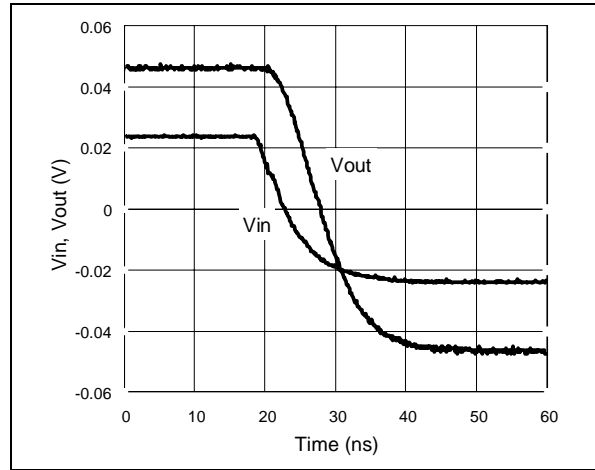

Channel separation (Xtalk) vs frequency
Measurement configuration : $X_{talk} = 20 \log(V_0/V_1)$

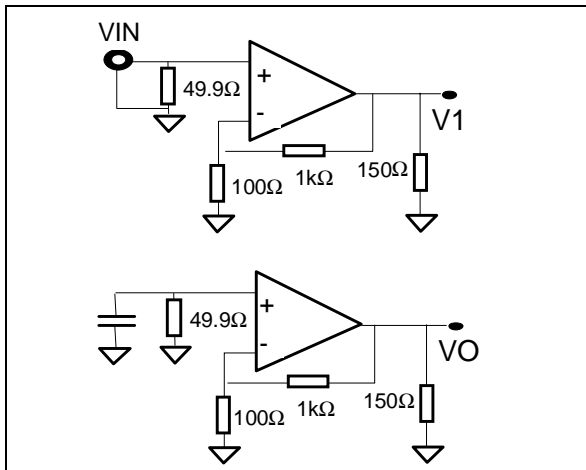

Channel separation (Xtalk) vs frequency
Gain=+11, Vcc=±5V, ZL=150Ω//27pF

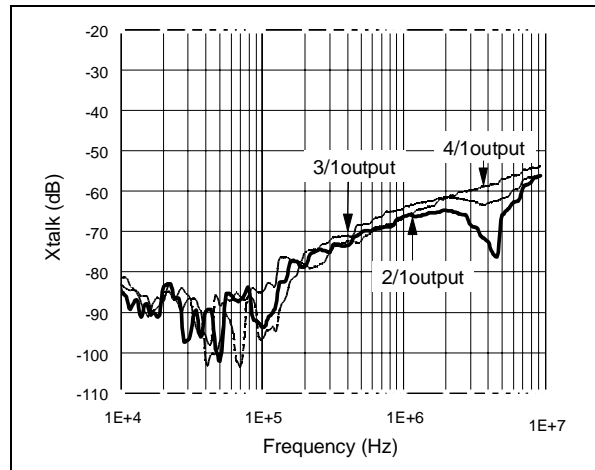

Equivalent Noise Voltage
Gain=100, Vcc=±5V, No load

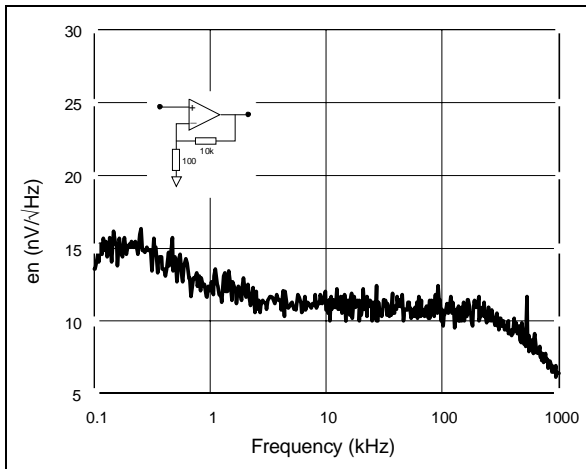

Maximum Output Swing
Gain=11, Vcc=±5V, RL=150Ω

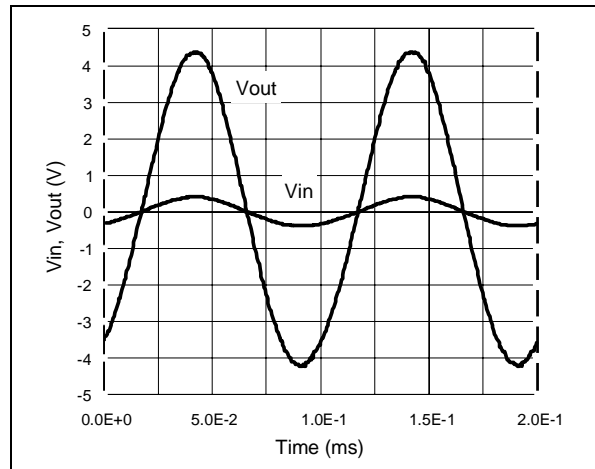

Standby Mode - Ton, Toff

Vcc=±5V, Open Loop

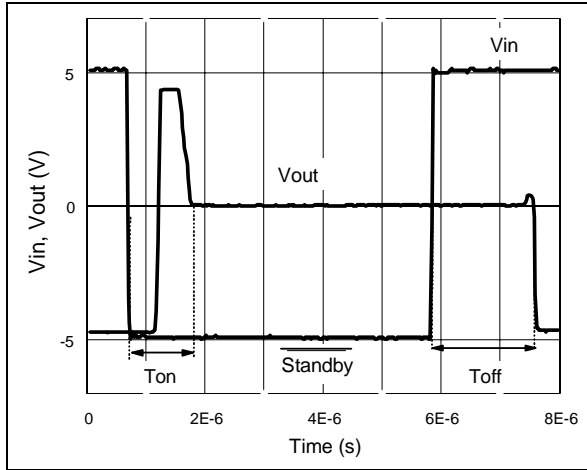

Group Delay

Gain=2, Vcc=±5V, ZL=150Ω//27pF, T_{amb} = 25°C

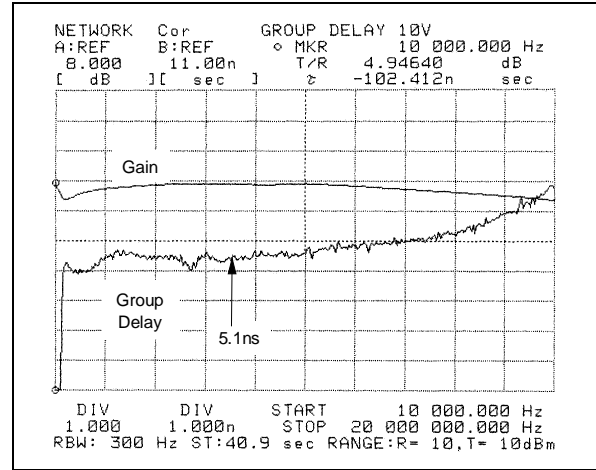

Intermodulation products

The IFR2026 synthesizer generates a two tones signal (F1=180kHz, F2=280kHz); each tone having the same amplitude level.

The HP3585 spectrum analyzer measures the intermodulation products function of the output voltage. The generator and the spectrum analyzer are phase locked for precision considerations.

Third Order Intermodulation

Gain=2, Vcc=±5V, ZL=150Ω//27pF, T_{amb} = 25°C

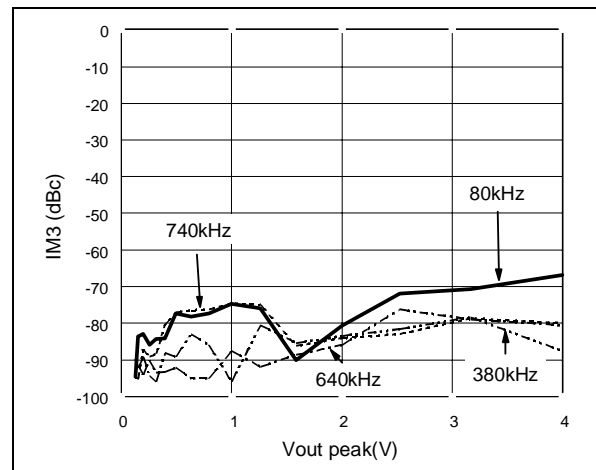

TESTING CONDITIONS:

Layout precautions:

To use the TSH7X circuits in the best manner at high frequencies, some precautions have to be taken for power supplies:

- First of all, the implementation of a proper ground plane in both sides of the PCB is mandatory for high speed circuit applications to provide low inductance and low resistance common return.

- Power supply bypass capacitors (4.7uF and ceramic 100pF) should be placed as close as possible to the IC pins in order to improve high frequency bypassing and reduce harmonic distortion. The power supply capacitors must be incorporated for both the negative and the positive pins.

- Proper termination of all inputs and outputs must be in accordance with output termination resistors; then the amplifier load will be only resistive and the stability of the amplifier will be improved.

All leads must be wide and as short as possible especially for op amp inputs and outputs in order to decrease parasitic capacitance and inductance.

- For lower gain application, attention should be paid not to use large feedback resistance (>1kΩ) to reduce time constant with parasitic capacitances.

- Choose component sizes as small as possible (SMD).

- Finally, on output, the load capacitance must be negligible to maintain good stability. You can put a serial resistance the closest to the output pin to minimize its influence.

CCIR330 video line

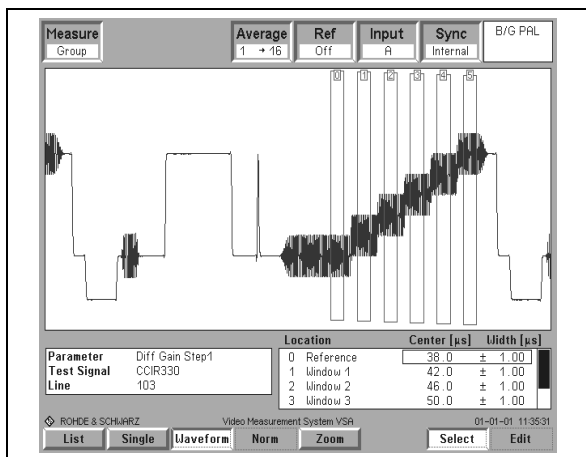

Maximum input level:

The input level must not exceed the following values:

- negative peak: must be greater than $-V_{cc}+400mV$.
- positive peak value: must be lower than $+V_{cc}-400mV$.

The electrical characteristics show the influence of the load on this parameter.

Video capabilities:

To characterize the differential phase and differential gain a CCIR330 video line is used.

The video line contains 5 (flat) levels of luma on which is superimposed chroma signal. (the first level contains no luma). The luma gives various amplitudes which define the saturation of the signal. The chrominance gives various phases which define the colour of the signal.

Differential phase (respectively differential gain) distortion is present if a signal chrominance phase (gain) is affected by luminance level. They represent the ability to uniformly process the high frequency information at all luminance levels.

When differential gain is present, colour saturation is not correctly reproduced.

The input generator is the Rohde & Schwarz CCVS. The output measurement is done by the Rohde and Schwarz VSA.

Measurement on Rohde and Schwarz VSA.

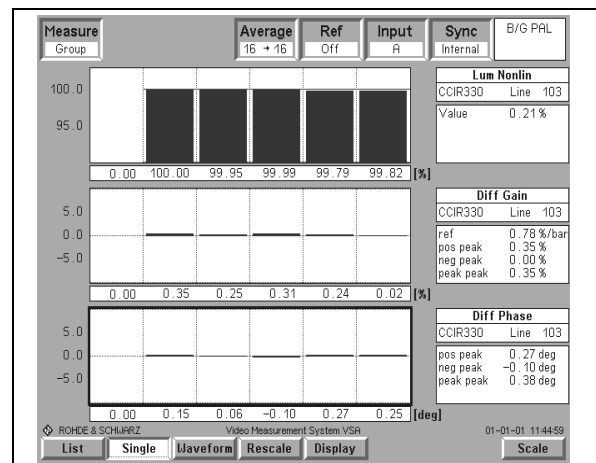

Video Results:

Parameter	Value Vcc=+-2.5V	Value Vcc=+-5V	Unit
Lum NL	0.1	0.3	%
Lum NL Step 1	100	100	%
Lum NL Step 2	100	99.9	%
Lum NL Step 3	99.9	99.8	%
Lum NL Step 4	99.9	99.9	%
Lum NL Step 5	99.9	99.7	%
Diff Gain pos	0	0	%
Diff Gain neg	-0.7	-0.6	%
Diff Gain pp	0.7	0.6	%
Diff Gain Step1	-0.5	-0.3	%
Diff Gain Step2	-0.7	-0.6	%
Diff Gain Step3	-0.3	-0.5	%
Diff Gain Step4	-0.1	-0.3	%
Diff Gain Step5	-0.4	-0.5	%
Diff Phase pos	0	0.1	deg
Diff Phase neg	-0.2	-0.4	deg
Diff Phase pp	0.2	0.5	deg
Diff Phase Step1	-0.2	-0.4	deg
Diff Phase Step2	-0.1	-0.4	deg
Diff Phase Step3	-0.1	-0.3	deg
Diff Phase Step4	0	0.1	deg
Diff Phase Step5	-0.2	-0.1	deg

Precautions on asymmetrical supply operation:

The TSH7X can be used either with a dual or a single supply. If a single supply is used, the inputs are biased to the mid-supply voltage (+Vcc/2). This bias network must be carefully designed, in order to reject any noise present on the supply rail.

As the bias current is 15uA, you must carefully choose the resistance R1 not to introduce an offset mismatch at the amplifier inputs.

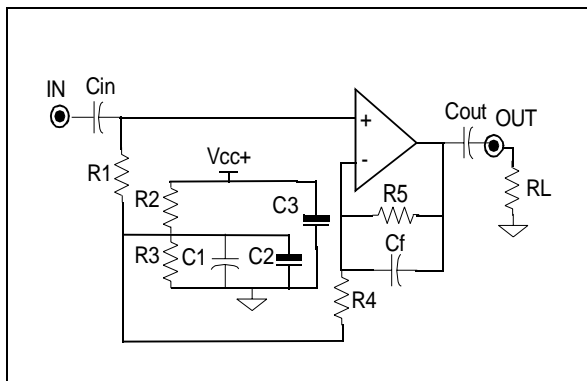

R1=10KΩ will be convenient. C1, C2, C3 are by-pass capacitors from perturbation on Vcc as well as for the input and output signals. We choose C1=100nF and C2=C3=100uF.

R2, R3 are such that the current through them must be superior to 100 times the bias current. So, we take R2=R3=4.7KΩ.

Cin, as Cout are chosen to filter the DC signal by the lowpass filters (R1,Cin) and (Rout, Cout). By taking R1=10KΩ, RL=150Ω, and Cin=2uF, Cout=220uF we provide a cutoff frequency below 10Hz.

Use of the TSH7X in gain=-1 configuration:

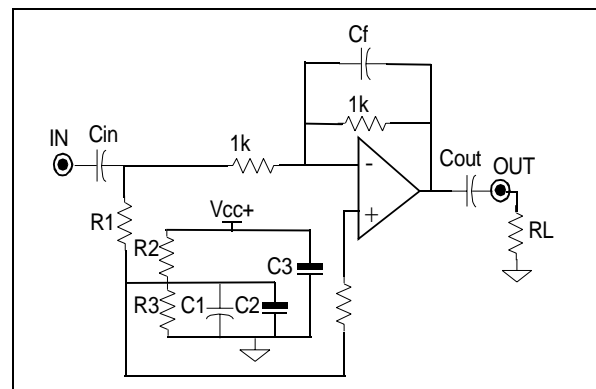

Some precautions have to be added, specially for low power supply application.

A feedback capacitance Cf should be added for better stability. The table summarizes the impact of the capacitance Cf on the phase margin of the circuit.

Parameter	Cf (pF)	Vcc=1.5V	Vcc=2.5V	Vcc=5V	Unit
Phase Margin	0	28	43	56	deg
f-3dB		40	39.3	38.3	MHz
Phase Margin	5.6	30	43	56	deg
f-3dB		40	39.3	38.3	MHz
Phase Margin	22	37	52	67	deg
f-3dB		37	34	32	MHz
Phase Margin	33	48	65	78	deg
f-3dB		33.7	30.7	27.6	MHz

Example of a video application :

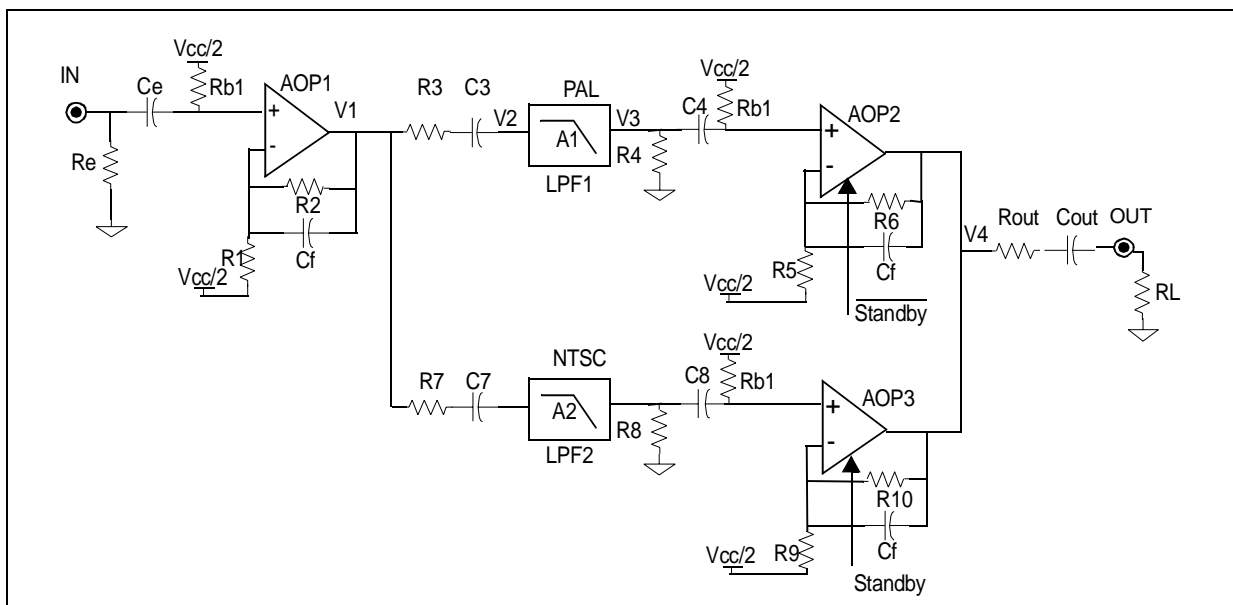

This example shows a possible application of the TSH7X circuit. Here, you can multiplex the channels for the different standard PAL, NTSC as you filter for the different bands; the video signal can be filtered with two different cutoff frequencies, corresponding to a PAL encoded signal (LPF1) or a NTSC signal (LPF2).

You can multiplex input signals, as the outputs are in high impedance state in standby mode. This enables you, to use a PAL filter as the Standby mode is active and to use the NTSC filter otherwise.

The video application requires 1V_{peak} at input and output.

Calculation of components:

A decoupling capacitor is provided to cutoff the frequencies below 10Hz according I bias. Hence Ce=10uF, with Rb1=10KΩ. At the output, Cout=220uF.

The AOP1 is in 6dB configuration for the adaptation bridge. R1=R2=1KΩ. V1=2V_{pk}. V2=1V_{pk}

For the PAL communication, we need a lowpass filtering. The load resistance R4 is function of the output resistance of the filter. V3=V2/A1 where A1 is the attenuation factor of the filter LPF1.

To compensate the filter insertion loss, we add an additional factor to the gain of the 2nd amplifier AOP2.

For example, for an attenuation of 3dB, we choose R5=300Ω and R6=1KΩ. We have V4=2V_{pk} and Vout=1V_{pk}.

The calculation of the parameters R7, C7, R8, C8, R9, R10 will be exactly the same .

TSH70, 71, 72, 73, 74, 75

PACKAGE MECHANICAL DATA 8 PINS - PLASTIC MICROPACKAGE (SO)

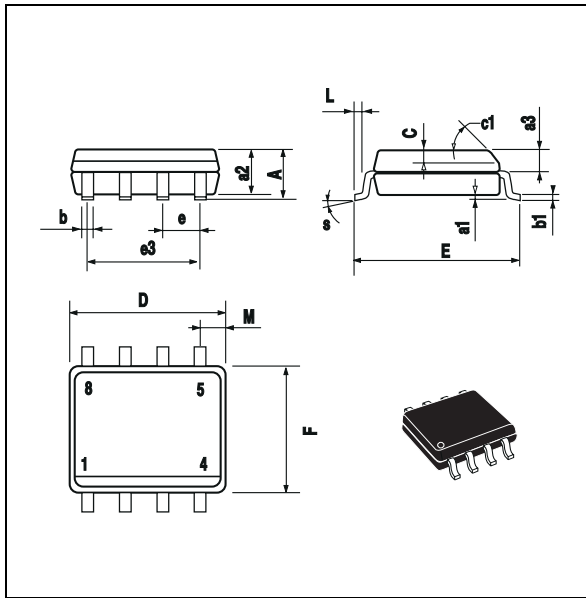

Dim.	Millimeters			Inches		
	Min.	Typ.	Max.	Min.	Typ.	Max.
A			1.75			0.069
a1	0.1		0.25	0.004		0.010
a2			1.65			0.065
a3	0.65		0.85	0.026		0.033
b	0.35		0.48	0.014		0.019
b1	0.19		0.25	0.007		0.010
C	0.25		0.5	0.010		0.020
c1	45° (typ.)					
D	4.8		5.0	0.189		0.197
E	5.8		6.2	0.228		0.244
e		1.27			0.050	
e3		3.81			0.150	
F	3.8		4.0	0.150		0.157
L	0.4		1.27	0.016		0.050
M			0.6			0.024
S	8° (max.)					

PACKAGE MECHANICAL DATA 8 PINS - THIN SHRINK SMALL OUTLINE PACKAGE (TSSOP)

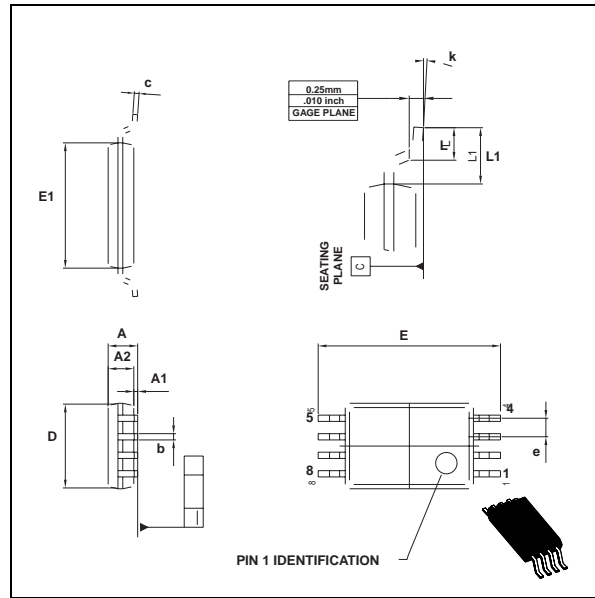

Dim.	Millimeters			Inches		
	Min.	Typ.	Max.	Min.	Typ.	Max.
A			1.20			0.05
A1	0.05		0.15	0.01		0.006
A2	0.80	1.00	1.05	0.031	0.039	0.041
b	0.19		0.30	0.007		0.15
c	0.09		0.20	0.003		0.012
D	2.90	3.00	3.10	0.114	0.118	0.122
E		6.40			0.252	
E1	4.30	4.40	4.50	0.169	0.173	0.177
e		0.65			0.025	
k	0°		8°	0°		8°
l	0.50	0.60	0.75	0.09	0.0236	0.030

PACKAGE MECHANICAL DATA
14 PINS - PLASTIC MICROPACKAGE (SO)

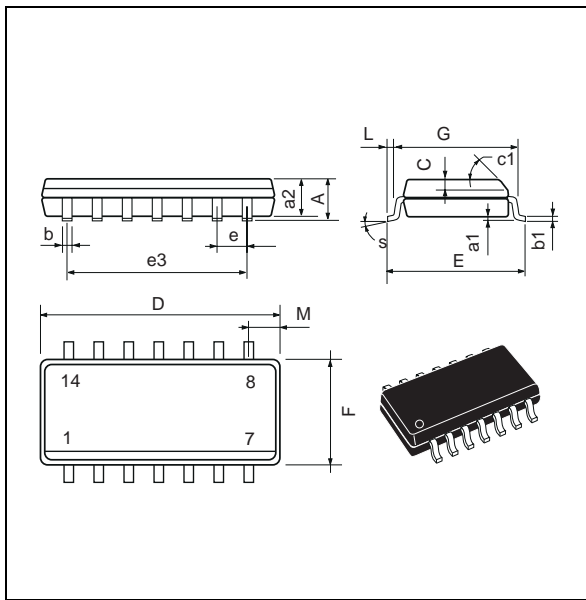

Dim.	Millimeters			Inches		
	Min.	Typ.	Max.	Min.	Typ.	Max.
A			1.75			0.069
a1	0.1		0.2	0.004		0.008
a2			1.6			0.063
b	0.35		0.46	0.014		0.018
b1	0.19		0.25	0.007		0.010
C		0.5			0.020	
c1	45° (typ.)					
D (1)	8.55		8.75	0.336		0.344
E	5.8		6.2	0.228		0.244
e		1.27			0.050	
e3		7.62			0.300	
F (1)	3.8		4.0	0.150		0.157
G	4.6		5.3	0.181		0.208
L	0.5		1.27	0.020		0.050
M			0.68			0.027
S	8° (max.)					

Note : (1) D and F do not include mold flash or protrusions - Mold flash or protrusions shall not exceed 0.15mm (.066 inc) ONLY FOR DATA BOOK.

PACKAGE MECHANICAL DATA
14 PINS - THIN SHRINK SMALL OUTLINE PACKAGE (TSSOP)

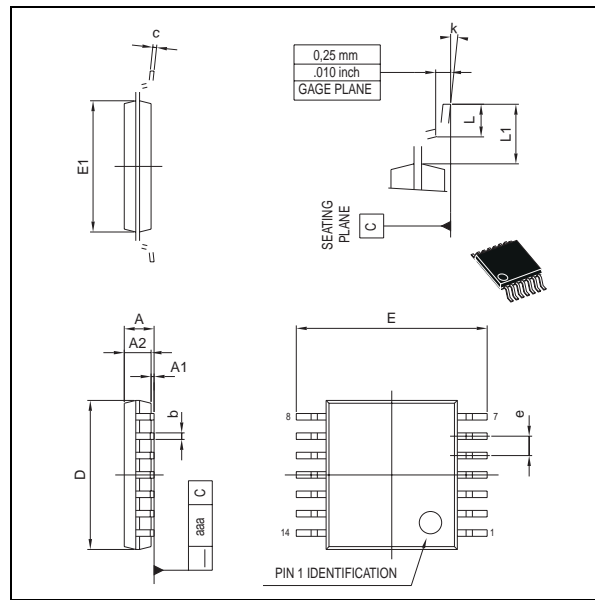

Dim.	Millimeters			Inches		
	Min.	Typ.	Max.	Min.	Typ.	Max.
A			1.20			0.05
A1	0.05		0.15	0.01		0.006
A2	0.80	1.00	1.05	0.031	0.039	0.041
b	0.19		0.30	0.007		0.15
c	0.09		0.20	0.003		0.012
D	4.90	5.00	5.10	0.192	0.196	0.20
E		6.40			0.252	
E1	4.30	4.40	4.50	0.169	0.173	0.177
e		0.65			0.025	
k	0°		8°	0°		8°
l	0.50	0.60	0.75	0.09	0.0236	0.030

TSH70, 71, 72, 73, 74, 75

PACKAGE MECHANICAL DATA 16 PINS - PLASTIC MICROPACKAGE (SO)

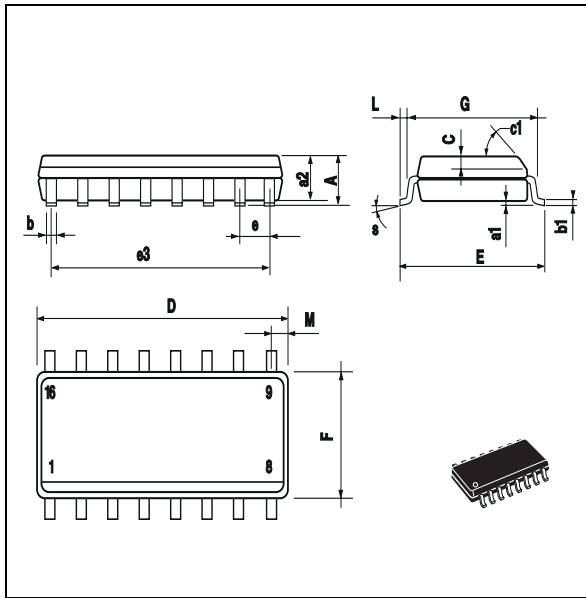

Dim.	Millimeters			Inches		
	Min.	Typ.	Max.	Min.	Typ.	Max.
A			1.75			0.069
a1	0.1		0.2	0.004		0.008
a2			1.6			0.063
b	0.35		0.46	0.014		0.018
b1	0.19		0.25	0.007		0.010
C		0.5			0.020	
c1	45° (typ.)					
D	9.8		10	0.386		0.394
E	5.8		6.2	0.228		0.244
e		1.27			0.050	
e3		8.89			0.350	
F	3.8		4.0	0.150		0.157
G	4.6		5.3	0.181		0.209
L	0.5		1.27	0.020		0.050
M			0.62			0.024
S	8° (max.)					

PACKAGE MECHANICAL DATA 16 PINS - THIN SHRINK SMALL OUTLINE PACKAGE (TSSOP)

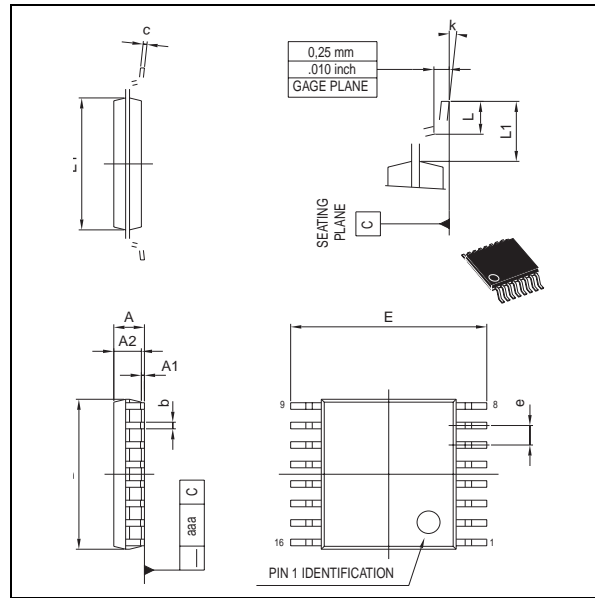

Dim.	Millimeters			Inches		
	Min.	Typ.	Max.	Min.	Typ.	Max.
A	0.90	1.20	1.45	0.035	0.047	0.057
A1	0		0.15			0.006
A2	0.90	1.05	1.30	0.035	0.041	0.051
B	0.35	0.40	0.50	0.014	0.016	0.020
C	0.09	0.15	0.20	0.004	0.006	0.008
D	2.80	2.90	3.00	0.110	0.114	0.118
D1		1.90			0.075	
e		0.95			0.037	
E	2.60	2.80	3.00	0.102	0.110	0.0118
F	1.50	1.60	1.75	0.059	0.063	0.069
L	0.10	0.5	0.60	0.004	0.014	0.024

PACKAGE MECHANICAL DATA
5 PINS - TINY PACKAGE (SOT23)

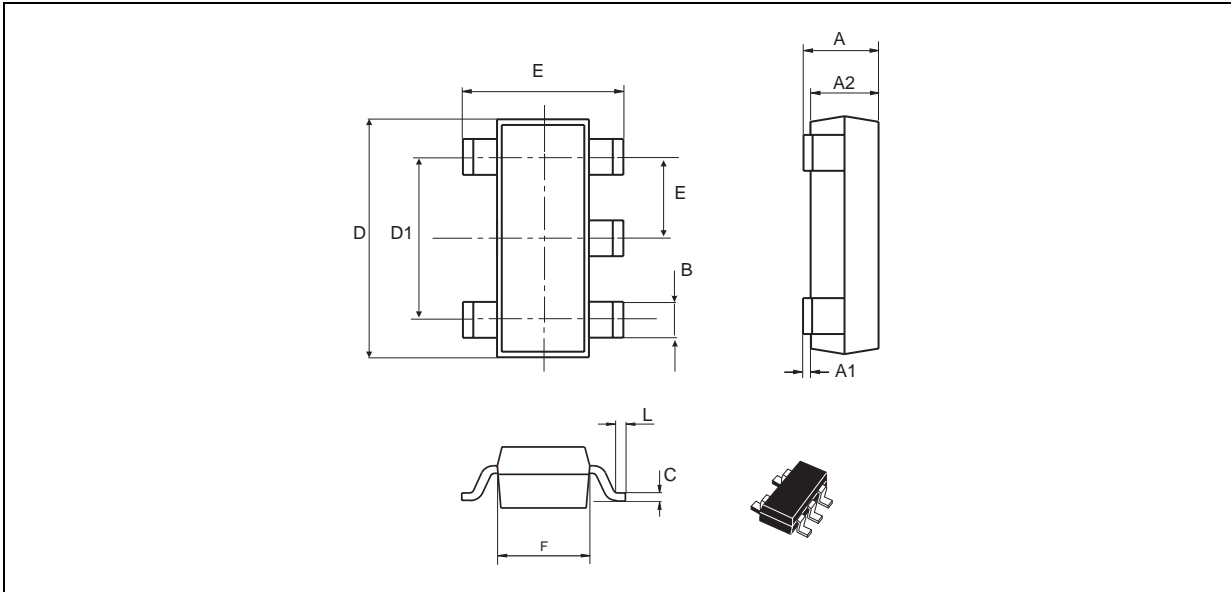

Dim.	Millimeters			Inches		
	Min.	Typ.	Max.	Min.	Typ.	Max.
A	0.90	1.20	1.45	0.035	0.047	0.057
A1	0		0.15			0.006
A2	0.90	1.05	1.30	0.035	0.041	0.051
B	0.35	0.40	0.50	0.014	0.016	0.020
C	0.09	0.15	0.20	0.004	0.006	0.008
D	2.80	2.90	3.00	0.110	0.114	0.118
D1		1.90			0.075	
e		0.95			0.037	
E	2.60	2.80	3.00	0.102	0.110	0.0118
F	1.50	1.60	1.75	0.059	0.063	0.069
L	0.10	0.5	0.60	0.004	0.014	0.024
K	0d		10d	0d		10d

Information furnished is believed to be accurate and reliable. However, STMicroelectronics assumes no responsibility for the consequences of use of such information nor for any infringement of patents or other rights of third parties which may result from its use. No license is granted by implication or otherwise under any patent or patent rights of STMicroelectronics. Specifications mentioned in this publication are subject to change without notice. This publication supersedes and replaces all information previously supplied. STMicroelectronics products are not authorized for use as critical components in life support devices or systems without express written approval of STMicroelectronics.

© The ST logo is a registered trademark of STMicroelectronics

© 2002 STMicroelectronics - Printed in Italy - All Rights Reserved
STMicroelectronics GROUP OF COMPANIES

Australia - Brazil - Canada - China - Finland - France - Germany - Hong Kong - India - Israel - Italy - Japan - Malaysia
Malta - Morocco - Singapore - Spain - Sweden - Switzerland - United Kingdom - United States

© <http://www.st.com>

