



STGB20NB37LZ

N-CHANNEL CLAMPED 20A D²PAK INTERNALLY CLAMPED PowerMESH™ IGBT

PRELIMINARY DATA

TYPE	V _{CES}	V _{CE(sat)}	I _C
STGB20NB37LZ	CLAMPED	< 2.0 V	20 A

- POLYSILICON GATE VOLTAGE DRIVEN
- LOW THRESHOLD VOLTAGE
- LOW ON-VOLTAGE DROP
- HIGH CURRENT CAPABILITY
- HIGH VOLTAGE CLAMPING FEATURE
- SURFACE-MOUNTING D²PAK (TO-263)
POWER PACKAGE IN TUBE (NO SUFFIX)
OR IN TAPE & REEL (SUFFIX "T4")

DESCRIPTION

Using the latest high voltage technology based on patented strip layout, STMicroelectronics has designed an advanced family of IGBTs with outstanding performances.

The built in collector-gate zener exhibits a very precise active clamping while the gate-emitter zener supplies an ESD protection.

APPLICATIONS

- AUTOMOTIVE IGNITION

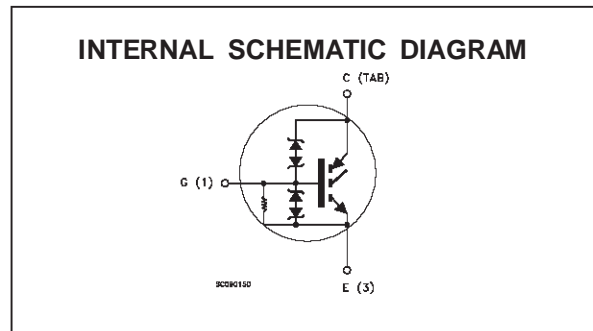
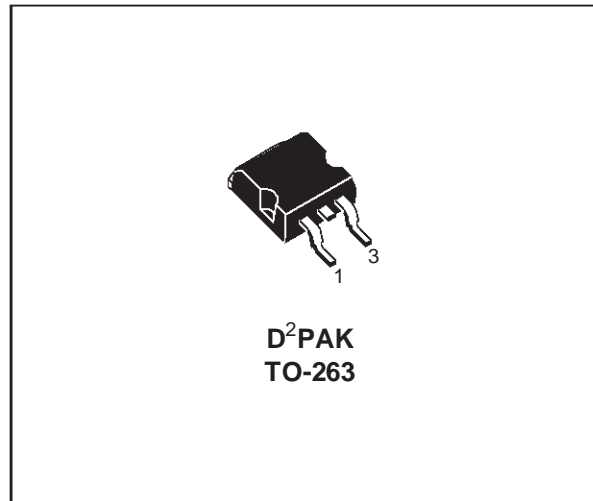

ABSOLUTE MAXIMUM RATINGS

Symbol	Parameter	Value	Unit
V _{CES}	Collector-Emitter Voltage (V _{GS} = 0)	CLAMPED	V
V _{ECR}	Reverse Battery Protection	20	V
V _{GE}	Gate-Emitter Voltage	CLAMPED	V
I _C	Collector Current (continuous) at T _c = 25 °C	40	A
I _C	Collector Current (continuous) at T _c = 100 °C	30	A
I _{CM} (•)	Collector Current (pulsed)	80	A
E _{AS}	Single Pulse Energy T _c = 25 °C	700	mJ
P _{tot}	Total Dissipation at T _c = 25 °C	150	W
	Derating Factor	1	W/°C
E _{SD}	ESD (Human Body Model)	4	KV
T _{stg}	Storage Temperature	-65 to 175	°C
T _j	Max. Operating Junction Temperature	175	°C

(•) Pulse width limited by safe operating area

STGB20NB37LZ

THERMAL DATA

R _{thj-case}	Thermal Resistance Junction-case	Max	1	°C/W
R _{thj-amb}	Thermal Resistance Junction-ambient	Max	62.5	°C/W
R _{thc-sink}	Thermal Resistance Case-sink	Typ	0.2	°C/W

ELECTRICAL CHARACTERISTICS (T_j = 25 °C unless otherwise specified)

OFF

Symbol	Parameter	Test Conditions	Min.	Typ.	Max.	Unit
BV _(CES)	Clamped Voltage	I _C = 2mA V _{GE} = 0 T _C = - 40°C	380	405	430	V
		I _C = 2mA V _{GE} = 0 T _C = 25°C	375	400	425	V
		I _C = 2mA V _{GE} = 0 T _C = 150°C	370	395	420	V
BV _(ECR)	Emitter Collector Break-down Voltage	I _C = 75 mA T _C = 25°C	20	28		V
BV _{GE}	Gate Emitter Break-down Voltage	I _G = ± 2 mA	12	14	16	V
I _{CES}	Collector cut-off Current (V _{GE} = 0)	V _{CE} = 15 V V _{GE} = 0 T _C = 150 °C			10	μA
		V _{CE} = 200 V V _{GE} = 0 T _C = 150 °C			100	μA
I _{GES}	Gate-Emitter Leakage Current (V _{CE} = 0)	V _{GE} = ± 10 V V _{CE} = 0	± 300	± 660	± 1000	μA
R _{GE}	Gate Emitter Resistance		10	15	30	KΩ

ON (*)

Symbol	Parameter	Test Conditions	Min.	Typ.	Max.	Unit
V _{GE(th)}	Gate Threshold Voltage	V _{CE} = V _{GE} I _C = 250μA T _C = - 40°C	1.2			V
		V _{CE} = V _{GE} I _C = 250μA T _C = 25°C	1.0	1.4	2	V
		V _{CE} = V _{GE} I _C = 250μA T _C = 150°C	0.6			V
V _{CE(SAT)}	Collector-Emitter Saturation Voltage	V _{GE} = 4.5 V I _C = 10 A T _C = 25°C		1.1	1.8	V
		V _{GE} = 4.5 V I _C = 10 A T _C = 150 °C		1.0	1.7	V
		V _{GE} = 4.5 V I _C = 20 A T _C = 25°C		1.35	2.0	V
		V _{GE} = 4.5 V I _C = 20 A T _C = 150 °C		1.25	2.0	V

DYNAMIC

Symbol	Parameter	Test Conditions	Min.	Typ.	Max.	Unit
g _{fs}	Forward Transconductance	V _{CE} = 25 V I _C = 20 A		35		S
C _{ies}	Input Capacitance	V _{CE} = 25 V f = 1 MHz V _{GE} = 0		2300		pF
C _{oes}	Output Capacitance			165		pF
C _{res}	Reverse Transfer Capacitance			28		pF
Q _G	Gate Charge	V _{CE} = 280 V I _C = 20 A V _{GE} = 5 V		51		nC

FUNCTIONAL CHARACTERISTICS

Symbol	Parameter	Test Conditions	Min.	Typ.	Max.	Unit
II	Latching Current	$V_{CLAMP} = 250\text{ V}$ $R_{G\text{OFF}} = 1\text{ K}\Omega$	$V_{GE} = 4.5\text{ V}$ $T_C = 150\text{ }^\circ\text{C}$	80		A
U.I.S.	Functional Test Open Secondary Coil	$R_{G\text{OFF}}=1\text{ K}\Omega$ $L=3\text{ mH}$ $R_{G\text{OFF}}=1\text{ K}\Omega$ $L=3\text{ mH}$	$T_C = 25\text{ }^\circ\text{C}$ $T_C = 150\text{ }^\circ\text{C}$	21.6 15	26 18	A A

SWITCHING ON

Symbol	Parameter	Test Conditions	Min.	Typ.	Max.	Unit
$t_{d(\text{on})}$ t_r	Delay Time Rise Time	$V_{CC} = 250\text{ V}$ $V_{GE} = 4.5\text{ V}$	$I_C = 20\text{ A}$ $R_G = 1\text{ K}\Omega$	2.3 0.6		μs μs
$(di/dt)_{\text{on}}$	Turn-on Current Slope	$V_{CC} = 250\text{ V}$ $R_G = 1\text{ K}\Omega$	$I_C = 20\text{ A}$ $V_{GE} = 4.5\text{ V}$	550		A/ μs
E_{on}	Turn-on Switching Losses	$V_{CC}=250\text{V}$ $R_G = 1\text{ K}\Omega$	$I_C = 20\text{A}$ $V_{GE} = 4.5\text{V}$	$T_C = 25\text{ }^\circ\text{C}$ $T_C = 150\text{ }^\circ\text{C}$	8.8 9.2	mJ mJ

SWITCHING OFF

Symbol	Parameter	Test Conditions	Min.	Typ.	Max.	Unit
t_c $t_r(V_{\text{off}})$ t_f $t_{d(\text{off})}$ $E_{\text{off}}^{(**)}$	Cross-Over Time Off Voltage Rise Time Fall Time Off Voltage Delay Time Turn-off Switching Loss	$V_{CC} = 250\text{ V}$ $R_{GE} = 1\text{ K}\Omega$	$I_C = 20\text{ A}$ $V_{GE} = 4.5\text{ V}$	4.8 2.6 2.0 11.5 11.8		μs μs μs μs mJ
t_c $t_r(V_{\text{off}})$ t_f $t_{d(\text{off})}$ $E_{\text{off}}^{(**)}$	Cross-Over Time Off Voltage Rise Time Fall Time Off Voltage Delay Time Turn-off Switching Loss	$V_{CC} = 250\text{ V}$ $R_{GE} = 1\text{ K}\Omega$ $T_C = 150\text{ }^\circ\text{C}$	$I_C = 20\text{ A}$ $V_{GE} = 4.5\text{ V}$	7.8 3.5 3.9 12.0 17.8		μs μs μs μs mJ

(*) Pulse width limited by safe operating area (*) Pulsed: Pulse duration = 300 ms, duty cycle 1.5 % (**) Losses Include Also The Tail (jedec Standardization)

Fig. 1: Unclamped Inductive Load Test Circuit

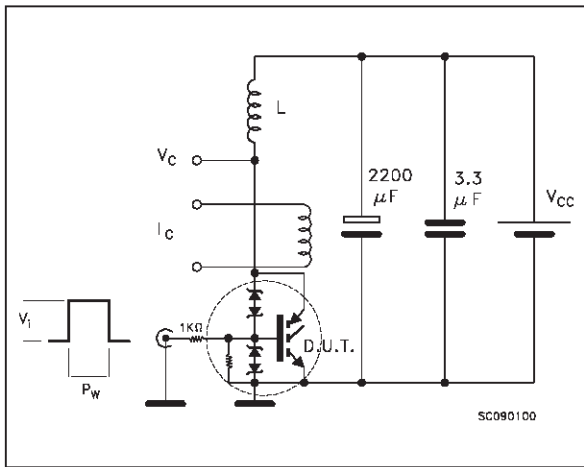

Fig. 2: Unclamped Inductive Waveform

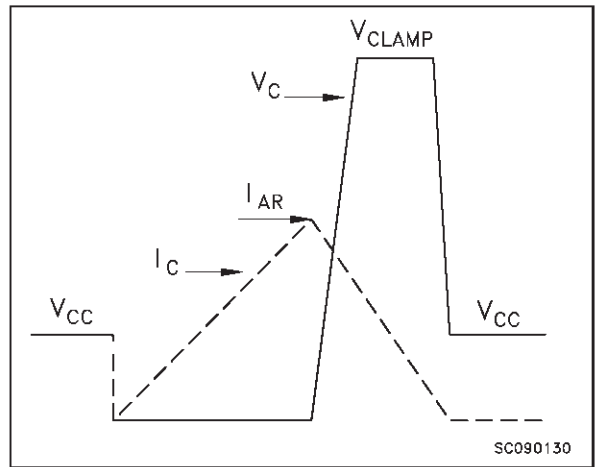

Fig. 3: Switching Times Test Circuits For Resistive Load

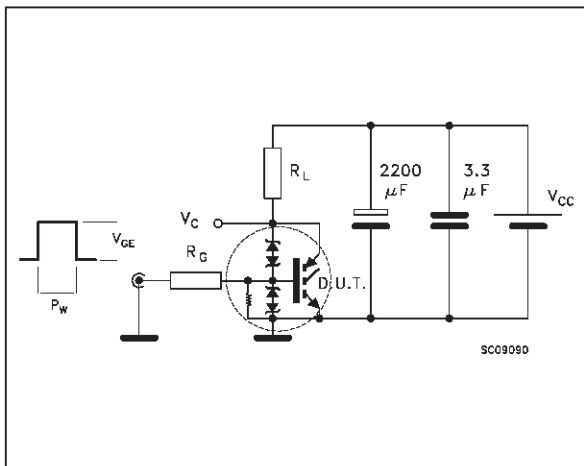

Fig. 4: Gate Charge test Circuit

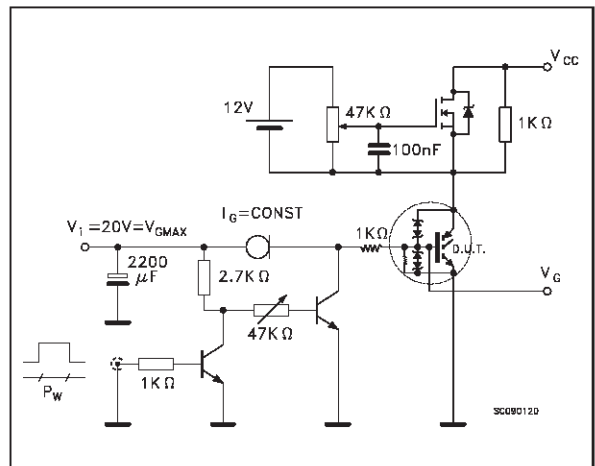
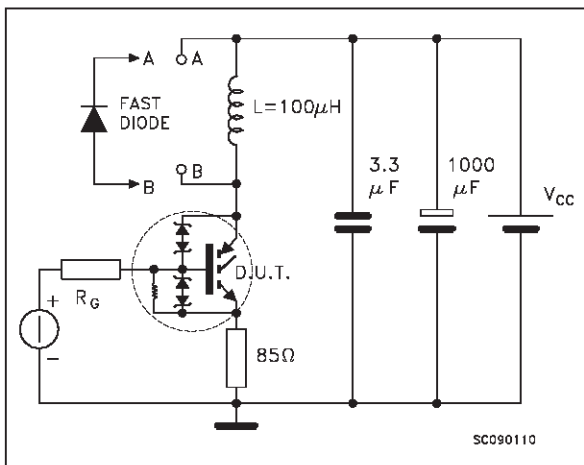
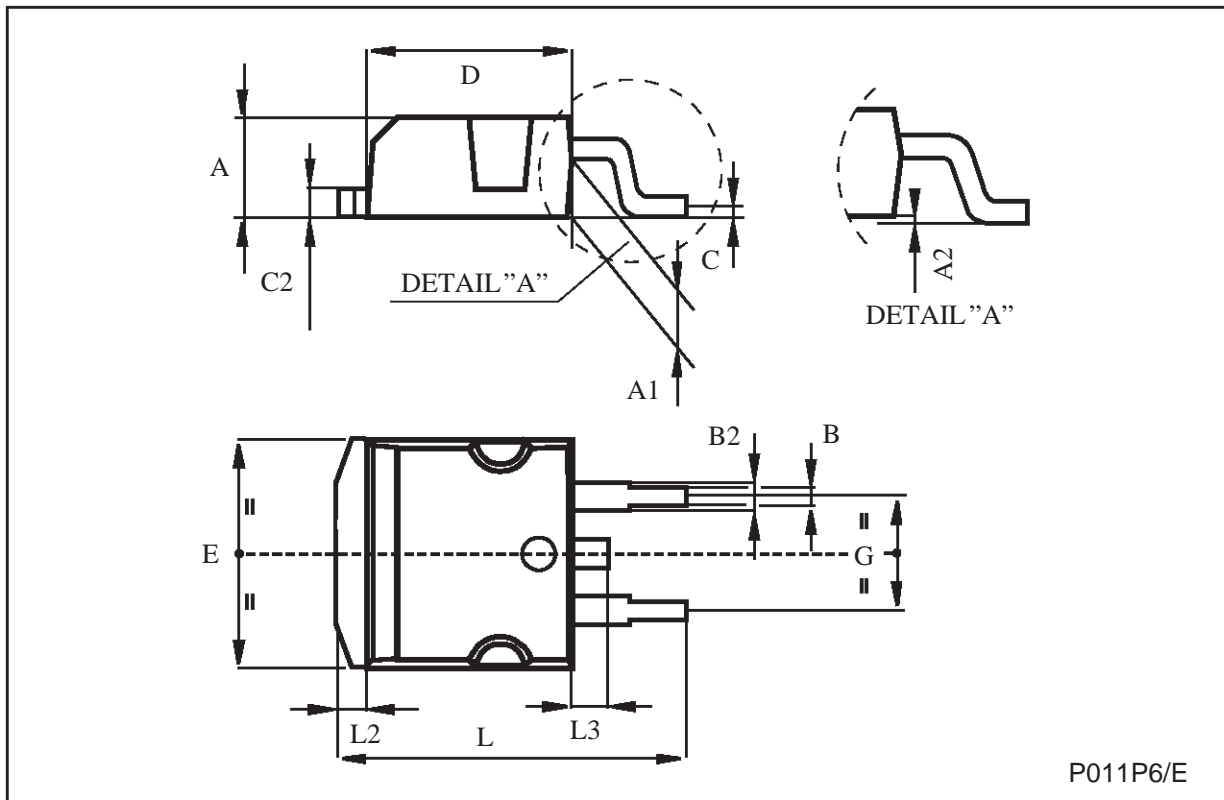

Fig. 5: Test Circuit For Inductive Load Switching And Diode Recovery Times



TO-263 (D²PAK) MECHANICAL DATA

DIM.	mm			inch		
	MIN.	TYP.	MAX.	MIN.	TYP.	MAX.
A	4.4		4.6	0.173		0.181
A1	2.49		2.69	0.098		0.106
B	0.7		0.93	0.027		0.036
B2	1.14		1.7	0.044		0.067
C	0.45		0.6	0.017		0.023
C2	1.21		1.36	0.047		0.053
D	8.95		9.35	0.352		0.368
E	10		10.4	0.393		0.409
G	4.88		5.28	0.192		0.208
L	15		15.85	0.590		0.624
L2	1.27		1.4	0.050		0.055
L3	1.4		1.75	0.055		0.068



Information furnished is believed to be accurate and reliable. However, STMicroelectronics assumes no responsibility for the consequences of use of such information nor for any infringement of patents or other rights of third parties which may result from its use. No license is granted by implication or otherwise under any patent or patent rights of STMicroelectronics. Specification mentioned in this publication are subject to change without notice. This publication supersedes and replaces all information previously supplied. STMicroelectronics products are not authorized for use as critical components in life support devices or systems without express written approval of STMicroelectronics.

The ST logo is a trademark of STMicroelectronics

© 1999 STMicroelectronics – Printed in Italy – All Rights Reserved
STMicroelectronics GROUP OF COMPANIES

Australia - Brazil - China - Finland - France - Germany - Hong Kong - India - Italy - Japan - Malaysia - Malta - Morocco -
Singapore - Spain - Sweden - Switzerland - United Kingdom - U.S.A.