

SIEMENS

SUPER-RED OLB 2600

YELLOW YLB 2700

GREEN GLB 2800

LIGHT BARS

T-41-31

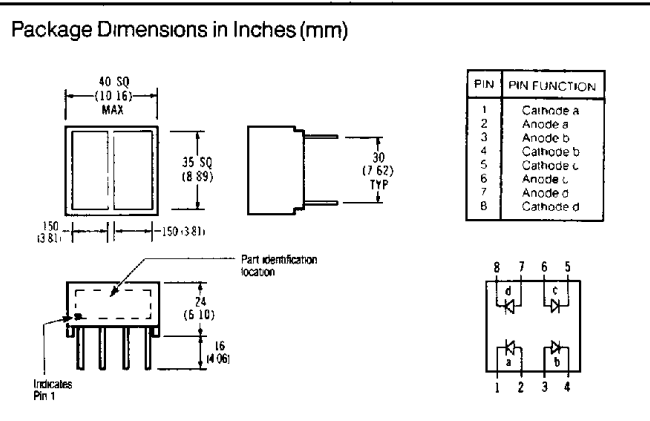
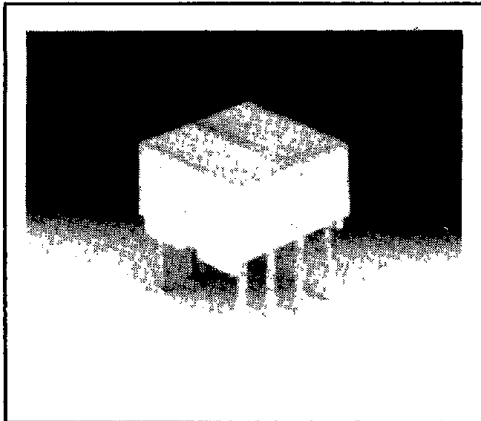

Num. Displays
Bar Graphs
Light Bars

FEATURES

- Square Package
- Mechanical barrier creating two isolated rectangular light emitting areas
- Uniform Light Emitting Area
- Excellent ON/OFF Contrast
- Choice of Three Colors
- Categorized for Light Output
- Yellow and Green Categorized for Dominant Wavelength
- Panel or Legend Mountable
- Can be Mounted on P.C. Boards or DIP Sockets
- X-Y Stackable
- Suitable for Multiplexing
- IC Compatible

APPLICATIONS

These devices are ideally suited for:

- Message Annunciators
- Positions/Status Indicators
- Telecommunications Indicators
- Bar Graphs

DESCRIPTION

The OLB 2600/YLB 2700/GLB 2800 series light bars are square displays. They are configured in a dual in-line package with a mechanical barrier creating two isolated rectangular light emitting areas. The OLB 2600 and YLB 2700 devices utilize four LED chips which are made from GaAsP on a transparent GaP substrate. The GLB 2800 device utilizes four chips made from GaP on a transparent GaP substrate.

Maximum Ratings

	OLB 2600 & GLB 2800	YLB 2700
Average Power Dissipation per LED chip	135mW	85mW
Peak Forward Current per LED chip	90mA	60mA
Ta = 50°C (max pulse width = 2ms)		
Average Forward Current per LED	25mA	20mA
Pulsed conditions (Ta = 50°C)		
DC Forward Current Per LED	30mA	25mA
(Ta = 50°C)		
Reverse Voltage per LED chip	6V	
Operating Temperature	-40°C to +85°C	
Storage Temperature	-40°C to +85°C	
Lead Soldering Temperature, 1/16 inch below seating plane	260°C for 3 sec	
Junction Temperature	100°C	

Electrical/Optical Characteristics (@ 25°C)

Parameters	Min.	Typ.	Max.	Units	Test Conditions
Luminous Intensity (per light emitting area)					
OLB2600	4.5	10		mcd	20mA DC
YLB2700	4	6		mcd	20mA DC
GLB2800	3.7	10		mcd	20mA DC
Peak Wavelength					
OLB2600		635		nm	
YLB2700		583		nm	
GLB2800		565		nm	
Dominant Wavelength					
OLB2600		626		nm	
YLB2700		585		nm	
GLB2800		572		nm	
Forward Voltage					
OLB2600	2.1	2.6		V	If = 20mA
YLB2700	2.2	2.6		V	If = 20mA
GLB2800	2.2	2.6		V	If = 20mA
Reverse Voltage					
OLB2600	6	15		V	IR = 100µA
YLB2700	6	15		V	IR = 100µA
GLB2800	6	15		V	IR = 100µA