

SIEMENS

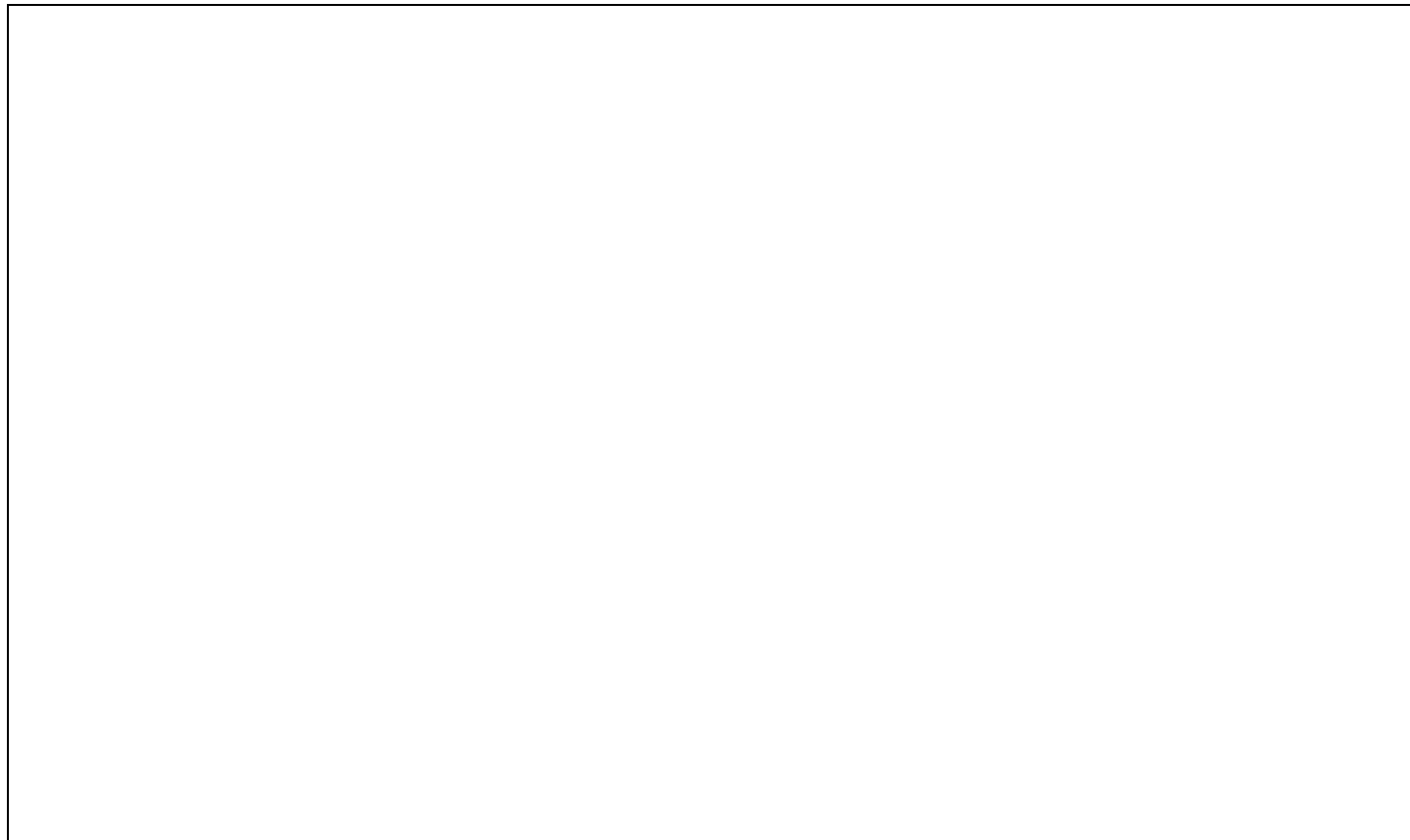

ICs for Communications

High Voltage Subscriber Line IC
HV-SLIC

PEB/F 4065 Version 3.0

Data Sheet 03.98
DS 1

[http://www.siemens.de/
Semiconductor/](http://www.siemens.de/Semiconductor/)

PEB/F 4065		
Revision History:		Current Version: 03.98
Previous Version:		01.96
Page (in previous Version)	Page (in current Version)	Subjects (major changes since last revision)

SLICOFI® is a registered trademark of SIEMENS AG.

For questions on technology, delivery and prices please contact the Semiconductor Group Offices in Germany or the Siemens Companies and Representatives worldwide: see our webpage at <http://www.siemens.de/Semiconductor/address/address.htm>.

Edition 03.98

**Published by Siemens AG,
HL SP,
Balanstraße 73,
81541 München**

© Siemens AG 1998.
All Rights Reserved.

Attention please!

As far as patents or other rights of third parties are concerned, liability is only assumed for components, not for applications, processes and circuits implemented within components or assemblies.

The information describes the type of component and shall not be considered as assured characteristics.

Terms of delivery and rights to change design reserved.

Due to technical requirements components may contain dangerous substances. For information on the types in question please contact your nearest Siemens Office, Semiconductor Group.

Siemens AG is an approved CECC manufacturer.

Packing

Please use the recycling operators known to you. We can also help you – get in touch with your nearest sales office. By agreement we will take packing material back, if it is sorted. You must bear the costs of transport.

For packing material that is returned to us unsorted or which we are not obliged to accept, we shall have to invoice you for any costs incurred.

Components used in life-support devices or systems must be expressly authorized for such purpose!

Critical components¹ of the Semiconductor Group of Siemens AG, may only be used in life-support devices or systems² with the express written approval of the Semiconductor Group of Siemens AG.

- 1 A critical component is a component used in a life-support device or system whose failure can reasonably be expected to cause the failure of that life-support device or system, or to affect its safety or effectiveness of that device or system.
- 2 Life support devices or systems are intended (a) to be implanted in the human body, or (b) to support and/or maintain and sustain human life. If they fail, it is reasonable to assume that the health of the user may be endangered.

Table of Contents		Page
1	Overview	4
1.1	Features	4
1.2	Functional Description	5
1.3	Pin Description	9
2	Electrical Characteristics	11
2.1	Absolute Maximum Ratings	11
2.2	Operating Range	12
2.3	Thermal Resistances	12
2.4	Electrical Parameters	13
2.5	AC-Characteristics	18
3	Package Outlines	29

1 Overview

The High Voltage Subscriber Line IC PEB 4065 is a rugged and reliable interface between the telephone line and the SLICOFI, a low voltage Subscriber Line Interface and Codec Filter IC. It is fabricated in a Smart Power Technology offering a breakthrough voltage of at least 170 V.

The PEB 4065 provides battery feeding between -24 V and -80 V and internal ringing injection with a differential ring voltage up to 85 V_{rms} . In order to achieve these high amplitudes an auxiliary positive battery voltage is used during ringing. This voltage can also be applied in order to drive very long telephone lines.

The SLIC is designed for a voltage feeding – current sensing line interface concept and provides sensing of transversal and longitudinal current on both wires.

A power-down mode offers reduced power consumption at full functionality; in the power denial mode the device is switched off turning the line outputs to a high impedance state.

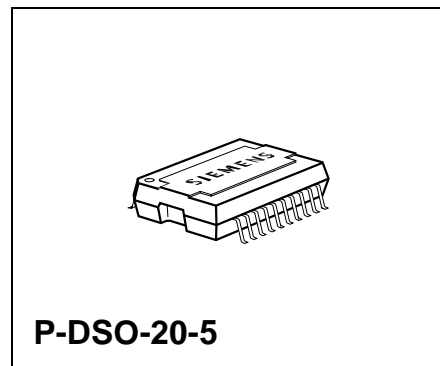

1.1 Features

- High voltage line feeding
- Internal ring and metering signal injection
- Sensing of transversal and longitudinal line current
- Reliable 170 V Smart Power Technology
- Battery voltage $-24\text{ V} \dots -80\text{ V}$
- Boosted battery mode for long telephone lines and up to 85 V_{rms} balanced ringing
- Polarity reversal
- Small P-DSO-20-5 power package

Type	Ordering Code	Package
PEB/F 4065	on request	P-DSO-20-5

1.2 Functional Description

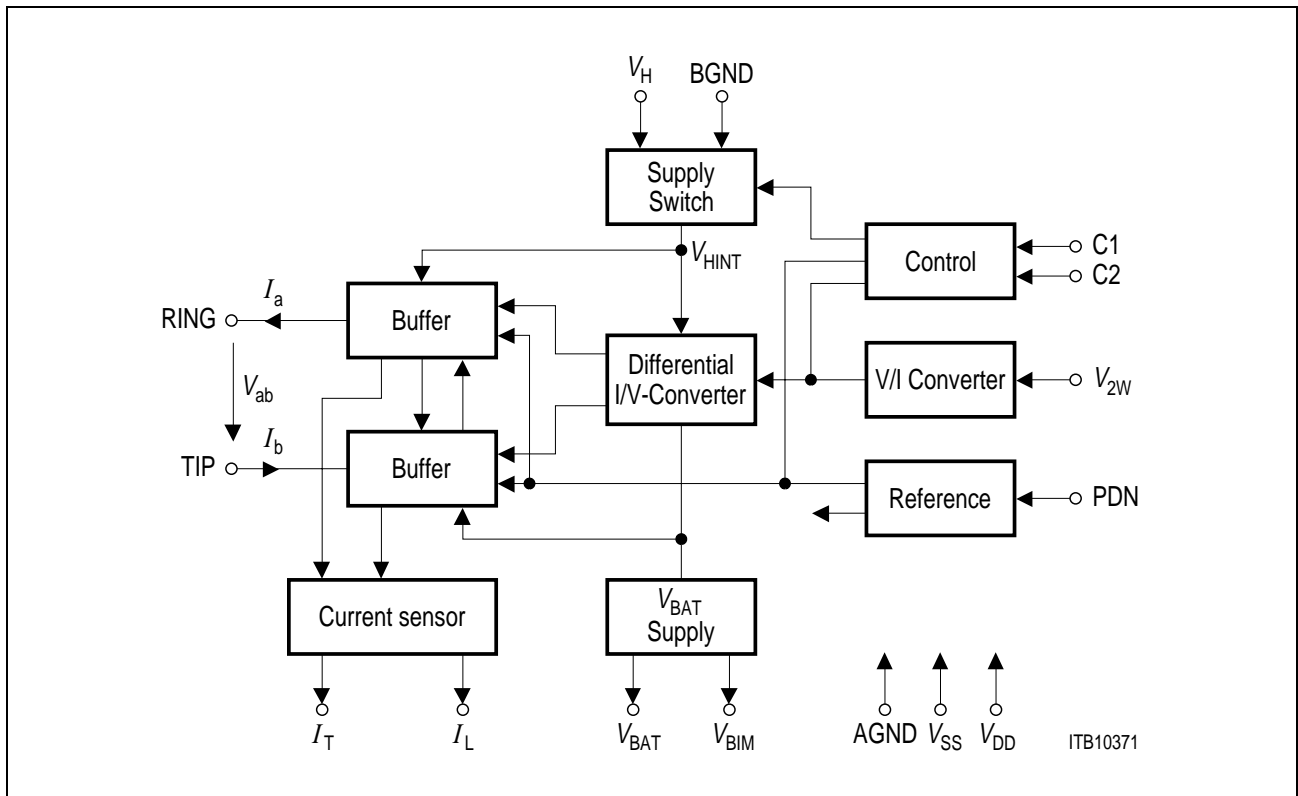

Figure 1 Block Diagram

The PEB 4065 supports AC and DC control loops based on feeding a voltage V_{ab} to the line and sensing the transversal line current I_{ab} (Figure 2).

It converts a unipolar input voltage V_{2W} into a differential output voltage V_{ab} with an AC receiving gain of

$$|Gr| = V_{abAC}/V_{2WAC} = 40.$$

This is accomplished by converting the input voltage to a current which is used to transpose the low voltage signals of the interface to the high voltage line feeding section. This current is reconverted to two voltages of opposite phase which are referenced to the positive and negative supply voltage, respectively. Thus the differential DC line-voltage in all normal polarity modes except ringing is related to the input voltage by

$$V_{abDC} = V_{BAT} - V_{HINT} + V_{fix} - 40 \times V_{2WDC}$$

V_{BAT} negative battery voltage

V_{HINT} internal positive supply voltage

V_{fix} internal voltage drop of supply filter (appr. 2 V).

Depending on the operation mode, V_{HINT} is switched either to V_H ($V_{HINT} = V_H - 1$ V) or to $BGND$ ($V_{HINT} = -0.5$ V) via the supply switch.

Overview

Controlled by C2, the polarity of V_{ab} can be reversed and the DC-line-voltage then is

$$V_{abDC} = - (V_{BAT} - V_{HINT} + V_{fix} - 40 \times V_{2WDC}).$$

The transversal and longitudinal currents are measured in the buffers and scaled images are provided at the I_T and I_L pin, respectively:

$$I_T = (I_a + I_b)/100 = I_{ab}/50 \quad I_L = - (I_a - I_b)/100 = - I_{Long}/50.$$

The PEB 4065 operates in four modes controlled by ternary logic signals at the C1 and C2 input. Additionally, in the active modes a polarity reversal of the output voltage can be programmed (see **Table 1**).

Power down (PD): Power consumption is reduced by decreasing bias current levels. All functions operate at some small performance reductions. In this mode each of the line outputs can be programmed to show high impedance. HI b switches off the TIP buffer, while the current through the RING output still can be measured by I_T or I_L . Programming HI a reverses the polarity and switches off the RING buffer.

Conversation (CONV): This is the regular transmit and receive mode for voiceband and teletax. The line driving section is operated between V_{BAT} and BGND.

Boosted battery (BB): In order to drive longer telephone lines an auxiliary positive battery voltage V_H is used, enabling a higher DC-voltage across the line.

Ringing (RING): This mode also uses the auxiliary voltage V_H in order to provide a balanced ring signal of up to 85 Vrms. The ring tone without any DC-component has to be switched to the V_{2W} input. Internally a DC-voltage is superimposed. This voltage is proportional to the total supply voltage $V_H - V_{BAT}$ and amounts to typically 23 V at $V_H - V_{BAT} = 120$ V. The current sensing functions are available for ring trip detection.

The Power Denial (PDN) state is intended to reduce power consumption of the linecard to a minimum: the PEB 4065 is switched off completely by connecting the PDN pin to V_{DD} , no operation is available.

With respect to the output impedance of TIP and RING two PDN-modes have to be distinguished. A resistive one (PDNR) provides a connection of 15 k Ω each from TIP to BGND and RING to V_{BAT} , respectively, while the outputs of the buffers show high impedance (**Figure 3**).

The other mode (PDNH) offers high impedance at TIP and RING. It is entered when, in addition to connecting PDN to V_{DD} , the programming inputs C1, C2 are tied to V_{IL} .

All other combinations of C1, C2 yield the resistive power denial state PDNR.

Table 1 Programming of Operation Modes

		C2 (Pin 13)		
		V _{IL}	V _{IZ}	V _{IH}
C1 (Pin 12)	V _{IL}	RING RP	RING NP	HI a RP
	V _{IZ}	BB RP	BB NP	HI b NP
	V _{IH}	CONV RP	CONV NP	PD NP

NP Normal Polarity RP...Reverse Polarity
 HI a RP Ring wire set to high impedance
 HI b NP Tip wire set to high impedance

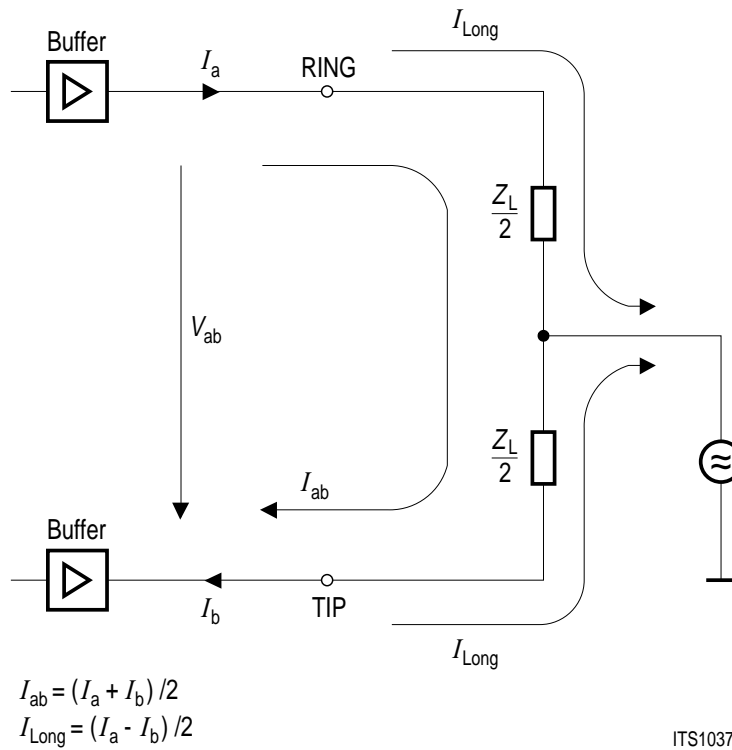

Figure 2 Definition of Output Current Directions

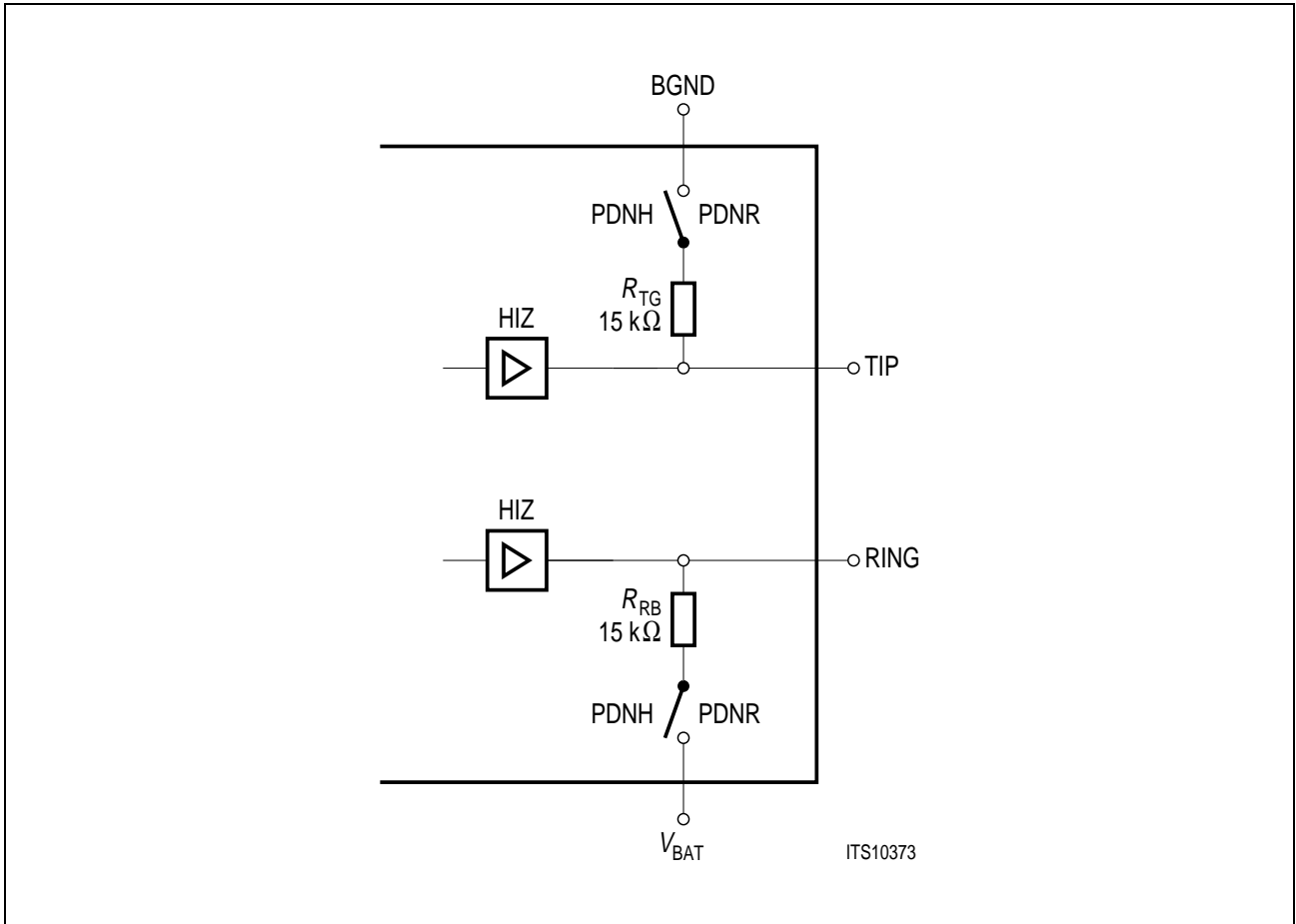

Figure 3 TIP and RING Impedance in Power Denial

1.3 Pin Description

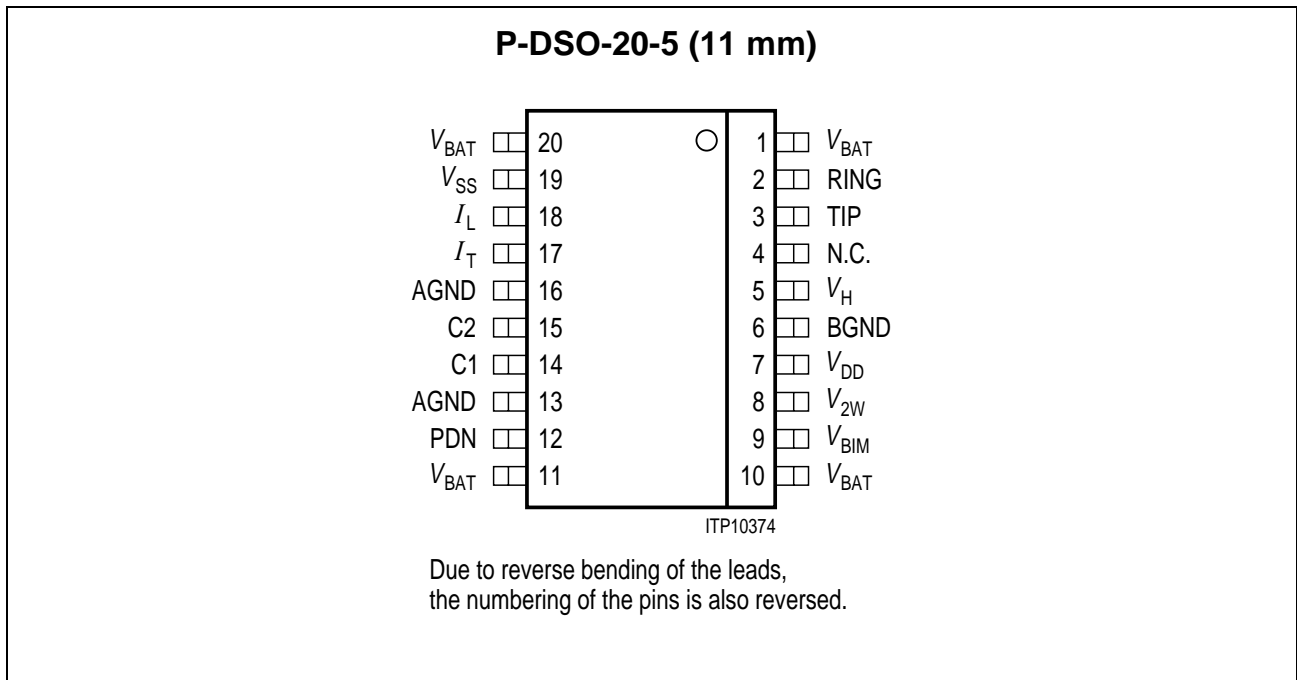

Figure 4 Pin Configuration (top view)

Table 2 Pin Definition and Functions

Pin No.	Symbol	Type Input (I) Output (O)	Function
1, 10, 11, 20	V_{BAT}	Supply	Negative battery supply voltage ($- 24 \dots - 80 \text{ V}$), referred to BGND
2	RING	O	Subscriber loop connection, negative wire in normal polarity; direction of positive I_a current out of this pin
3	TIP	O	Subscriber loop connection, more positive wire in normal polarity; direction of positive I_b current into this pin
4	–	N.C.	Not connected
5	V_H	Supply	Auxiliary positive battery supply voltage ($0 \dots + 90 \text{ V}$) used in ringing and boosted battery mode
6	BGND	Supply	Battery ground: TIP, RING, V_{BAT} and V_H refer to this pin
7	V_{DD}	Supply	Positive supply voltage ($+ 5 \text{ V}$), referred to AGND

Table 2 Pin Definition and Functions (cont'd)

Pin No.	Symbol	Type Input (I) Output (O)	Function
8	V_{2W}	I	Two wire input voltage; multiplied by + 20 and – 20, respectively, it appears at the TIP and RING outputs
9	V_{BIM}	O	Down scaled image of the total supply voltage ($V_{HINT} - V_{BAT}$); scaling factor 40
12	PDN	I/O	Power denial, reference output when connected to ground via a resistor, switches the device off when connected to V_{DD}
13, 16	AGND	Supply	Analog ground: V_{DD} , V_{SS} and all signal and control pins with exception of TIP and RING refer to AGND
14	C1	I/O	Ternary logic input, controlling the operation mode; in case of thermal overload this pin sinks a current of typ. 550 μ A
15	C2	I	Ternary logic input, controlling the operation mode
17	I_T	O	Current output representing the transversal current scaled down by 50; In normal polarity this pin sinks the I_T current.
18	I_L	O	Current output representing the longitudinal current scaled down by 50; For I_{long} flowing out of TIP and RING this pin sinks the I_L current.
19	V_{SS}	Supply	Negative supply voltage (– 5 V), referred to AGND

Electrical Characteristics

2 Electrical Characteristics

2.1 Absolute Maximum Ratings

Table 3

Parameter	Symbol	Limit Values		Unit	Condition
		min.	max.		
Battery voltage	V_{BAT}	- 90	0.5	V	referred to BGND
Auxiliary supply voltage	V_H	- 0.5	90	V	referred to BGND
Total battery supply voltage, continuously	$V_H - V_{BAT}$	-	160	V	-
Total battery supply voltage, pulse < 1 ms	$V_H - V_{BAT}$	-	170	V	-
V_{DD} supply voltage	V_{DD}	- 0.4	5.5	V	referred to AGND
V_{SS} supply voltage	V_{SS}	- 5.5	0.4	V	referred to AGND
Ground voltage difference	$V_{BGND} - V_{AGND}$	- 0.5	0.5	V	-
Junction temperature	T_j	-	150	°C	-
Input voltages	V_{2W}, V_{C1}, V_{C2}	$V_{SS} - 0.3$	$V_{DD} + 0.3$	V	-
Voltages on current outputs	V_{IT}, V_{IL}	- 3.5	$V_{DD} + 0.3$	V	-
Voltages on PDN	V_{PDN}	- 0.3	$V_{DD} + 0.3$	V	-
RING, TIP voltages, continuously	V_a, V_b	$V_{BAT} - 0.3$	$V_H + 0.3$	V	-
RING, TIP voltages, pulse < 1 ms ¹⁾	V_a, V_b	$V_{BAT} - 10$	$V_H + 10$	V	-
RING, TIP voltages, pulse < 1 μs ¹⁾	V_a, V_b	$V_{BAT} - 30$	$V_H + 30$	V	-
ESD-voltage, all pins	-	-	1	kV	Human body model

¹⁾ See Test Figure 10.

Note: Maximum ratings are absolute ratings; exceeding only one of these values may cause irreversible damage to the integrated circuit.

Electrical Characteristics

2.2 Operating Range

Table 4

Parameter	Symbol	Limit Values		Unit	Condition
		min.	max.		
Battery voltage	V_{BAT}	- 80	- 24	V	referred to BGND
Auxiliary supply voltage	V_H	5	85	V	referred to BGND
Total battery supply voltage	$V_H - V_{BAT}$	-	150	V	-
V_{DD} supply voltage	V_{DD}	4.75	5.25	V	referred to AGND
V_{SS} supply voltage	V_{SS}	- 5.25	- 4.75	V	referred to AGND
Ground voltage difference	-	- 0.3	0.3	V	-
Ambient temperature	T_{amb}	0 - 40	70 85	°C °C	PEB 4065 PEF 4065
Voltage compliance I_T, I_L	V_{IT}, V_{IL}	- 3	3	V	-
Input range V_{2W}	V_{2W}	- 3.2 - 3.2	+ 3.2 0	V V	RING CONV, PD, BB

Note: In the operating range the functions given in the circuit description are fulfilled.

2.3 Thermal Resistances

Table 5

Parameter	Symbol	Limit Values	Unit	Condition
Junction to case	$R_{th,jC}$	5	K/W	-
Junction to ambient	$R_{th,jA}$	20	K/W	with heatsink, typ.

Electrical Characteristics

2.4 Electrical Parameters

Min/max values are valid within the full operating range. If PEB- and PEF-specifications are different, both values can be found in the respective column.

Testing is performed according to the test figures with external circuitry as depicted in **Figure 4**. Unless otherwise stated, load impedance $R_L = 600 \Omega$. Test temperatures are 25 and 70 °C for PEB, -40, 25 and 85 °C for PEF-type (without heatsink). DC line voltages refer to $V_{BAT} = -70 \text{ V}$ and $V_H = +60 \text{ V}$.

Table 6 Supply Currents and Power Dissipation

No.	Parameter	Symbol	Mode	Limit Values			Unit	Test Fig.
				min.	typ.	max. PEB/PEF		
Power Denial								
1.	V_{DD} current	I_{DD}	PDNH, PDNR	–	50	120/150	μA	1
2.	V_{SS} current	I_{SS}	PDNH PDNR	–	50 150	120/150 250/300	μA	1
3.	V_{BAT} current	I_{BAT}	PDNH PDNR	–	10 50	30 120	μA	1
4.	V_H current	I_H	PDNH, PDNR	–	1	10	μA	1
Power Down $V_{2W} = -0.5 \text{ V}^1)$								
5.	V_{DD} current	I_{DD}	PD	–	0.5	1.0	mA	1
6.	V_{SS} current	I_{SS}	PD	–	0.3	0.4	mA	1
7.	V_{BAT} current	I_{BAT}	PD	–	3.3	4.3/4.4	mA	1
8.	V_H current	I_H	PD	–	1	10	μA	1
9.	Quiescent power dissipation	P_Q	PD	–	–	315	mW	1
Conversation, Normal and Reverse Polarity $V_{2W} = -0.5 \text{ V}^1)$								
10.	V_{DD} current	I_{DD}	CONV	–	0.8	1.0/1.1	mA	1
11.	V_{SS} current	I_{SS}	CONV	–	0.4	0.5/0.6	mA	1
12.	V_{BAT} current	I_{BAT}	CONV	–	4.0	5.8/5.9	mA	1
13.	V_H current	I_H	CONV	–	1	10	μA	1
14.	Quiescent power dissipation	P_Q	CONV	–	–	420	mW	1

Electrical Characteristics

Table 6 Supply Currents and Power Dissipation (cont'd)

No.	Parameter	Symbol	Mode	Limit Values			Unit	Test Fig.
				min.	typ.	max. PEB/PEF		
Boosted Battery Mode Normal and Reverse Polarity							$V_{2W} = -0.5 \text{ V}^1)$	
15.	V_{DD} current	I_{DD}	BB	–	0.8	1.0	mA	1
16.	V_{SS} current	I_{SS}	BB	–	1.7	2.0	mA	1
17.	V_{BAT} current	I_{BAT}	BB	–	4.0	6.1/6.2	mA	1
18.	V_H current	I_H	BB	–	3.0	4.8	mA	1
19.	Quiescent power dissipation	P_Q	BB	–	–	740	mW	1
Ring Mode Normal and Reverse Polarity							$V_{2W} = 0 \text{ V}$	
20.	V_{DD} current	I_{DD}	RING	–	2.3	2.6	mA	1
21.	V_{SS} current	I_{SS}	RING	–	2.8	3.2	mA	1
22.	V_{BAT} current	I_{BAT}	RING	–	8.8	12/12.5	mA	1
23.	V_H current	I_H	RING	–	7.1	10	mA	1
24.	Quiescent power dissipation	P_Q	RING	–	1300	1500	mW	1

¹⁾ I_{BAT} and I_H depend on the value of V_{2W} :

$$I_{BAT}(V_{2W}) = I_{BAT(0)} + |V_{2W}|/440 \Omega \quad \text{typ. (PD, CONV, BB)}$$

$$I_H(V_{2W}) = I_{H(0)} + |V_{2W}|/440 \Omega \quad \text{typ. (BB)}$$

Electrical Characteristics

Table 7 DC-Characteristics

No.	Parameter	Symbol	Mode	Limit Values			Unit	Test Fig.	Test Condition
				min. PEB/ PEF	typ.	max. PEB/ PEF			
Line Termination TIP, RING									
25.	Power down DC line voltage	$ V_{ab,DC} $	PD	46	49	52	V	2	$V_{2W} = -0.5\text{ V}$
26.			PD	- 14	- 11	- 8	V		$V_{2W} = -2\text{ V}$
27.	Conversation DC line voltage	$ V_{ab,DC} $	CONV	65	66.5	68.5	V	2	$V_{2W} = 0\text{ V}$
28.			CONV	46.6	47.8	48.8	V		$V_{2W} = -0.5\text{ V}$
29.			CONV	- 14	- 12.2	- 10.4	V		$V_{2W} = -2\text{ V}$
30.	Ring DC line voltage	$ V_{ab,DC} $	RING	22.1	25	27.7	V	2	$V_{2W} = 0\text{ V}$
31.	Output current limit	$ I_{a,max} $, $ I_{b,max} $	PD others	85/80 90/85	- -	130 130/ 135	mA mA	3	$V_{2W} = -0.5\text{ V}$ V_a, V_b acc. to Test Figure 3
32.	Loop open resistance TIP to BGND	R_{TG}	PDNR	12/11	15	18/19	k Ω	9	$I_b = 2\text{ mA}$
33.	Loop open resistance RING to V_{BAT}	R_{RB}	PDNR	12/11	15	18/19	k Ω		$I_a = 2\text{ mA}$
34.	Power denial output leakage current	$I_{Leak,a}$	PDNH	- 30	-	30	μA	-	$V_{BAT} < V_a < V_H$
35.		$I_{Leak,b}$		- 30	-	30	μA		$V_{BAT} < V_a < V_H$
36.	High impedance output leakage current	$I_{Leak,a}$	HI a	- 30	-	30	μA	-	$V_{BAT} < V_a < V_{H-3}$
37.		$I_{Leak,b}$	HI b	- 30	-	30	μA		$V_{BAT} < V_b < V_{H-3}$

Electrical Characteristics

Table 7 DC-Characteristics (cont'd)

No.	Parameter	Symbol	Mode	Limit Values			Unit	Test Fig.	Test Condition
				min. PEB/ PEF	typ.	max. PEB/ PEF			
Reference Voltage Outputs PDN, V_{BIM}									
38.	Output voltage on PDN	V_{ref}	all	1.15	1.25	1.35	V	1	–
39.	Battery image voltage	V_{BIM}	CONV, PD	– 1.75	– 1.7	– 1.65	V	1	–
40.			BB, RING	– 3.25	– 3.18	– 3.1	V		
Two-wire Input V_{2W}									
41.	Input current	I_{2W}	all	– 30	–	30	μ A	–	$– 3.2 \text{ V} < V_{2W} < 3.2 \text{ V}$
42.	Input capacitance	–	–	–	–	20	pF	–	–
Current Outputs I_T, I_L $V_{2W} = -0.5 \text{ V}$									
43.	I_T output current	$ I_T $	PD, CONV	–	–	15	μ A	2	$I_a = I_b = 0$
44.			PD, CONV	380		420	μ A		$I_a = I_b = 20 \text{ mA}^{1)}$
45.			CONV	0.95		1.05	mA		$I_a = I_b = 50 \text{ mA}^{1)}$
46.			RING			20	μ A		$I_a = I_b = 0$
47.	I_L output current	$ I_L $	PD, CONV	–	–	30	μ A	2	$I_a = I_b = 0$
48.			PD, CONV			30	μ A		$I_a = I_b = 20 \text{ mA}^{1)}$
49.			PD, CONV	65		135	μ A		$I_a = 15 \text{ mA},$ $I_b = 25 \text{ mA}$
50.			CONV	180		320	μ A		$I_a = 37.5 \text{ mA},$ $I_b = 62.5 \text{ mA}$

Electrical Characteristics

Table 7 DC-Characteristics (cont'd)

No.	Parameter	Symbol	Mode	Limit Values			Unit	Test Fig.	Test Condition
				min. PEB/ PEF	typ.	max. PEB/ PEF			
Control Inputs C1, C2									
51.	H-input voltage	V_{IH}	all	2	–	–	V	–	–
52.	Z-input voltage	V_{IZ}	all	– 0.8	–	0.8	V	–	–
53.	L-input voltage	V_{IL}	all	–	–	– 2	V	–	–
54.	Input leakage current	I_{Leak}	all	– 5	–	5	μA	–	$- 5 V < V_{C1(2)} < + 5 V$
55.	Thermal overload current C1	I_{therm}	all	500	550	–	μA	–	$V_{C1} = - 3.2 V$
56.	Switching Temperature (guaranteed by design)	T_{joff}	all	–	165	–	$^{\circ}C$	–	–
		T_{jon}	all	–	145	–	$^{\circ}C$	–	–

¹⁾ Polarity of I_a and I_b is reversed for measurement in reverse polarity mode

Note: The listed characteristics are ensured over the operating range of the integrated circuit. Typical characteristics specify mean values expected over the production spread. If not otherwise specified, typical characteristics apply at $T_A = 25^{\circ}C$ and the given supply voltage.

Electrical Characteristics

2.5 AC-Characteristics

(Normal and reverse polarity unless otherwise stated)

Table 8

No.	Parameter	Symbol	Mode	Limit Values			Unit	Test Fig.	Test Condition
				min.	typ.	max. PEB/ PEF			
Line Termination TIP, RING									
57.	Receive gain	Gr	CONV, BB	31.92	32.04	32.16	dB	4	$V_{2W,AC} = 50 \text{ mVrms}$ $f = 1015 \text{ Hz}$ $I_{ab} = 20 \text{ mA}$
58.			CONV	31.88	32.04	32.2	dB		$I_{ab} = 50 \text{ mA}$
59.	Gain flatness (guaranteed by design)	dGr	CONV, BB	- 0.05	-	0.05	dB	-	$300 \text{ Hz} < f < 3400 \text{ Hz}$ $V_{2W,AC} = 50 \text{ mVrms}$
60.	Gain tracking (guaranteed by design)	dGr	CONV	- 0.2	-	0.2	dB	-	$3 \text{ dBm0} > V_{ab} >$ $- 20 \text{ dBm0}$ $f = 1015 \text{ Hz}$
61.	Total harmonic distortion V_{ab}	THD	CONV	-	-	0.3	%	4	$V_{2W,AC} = 50 \text{ mVrms}$ $f = 1015 \text{ Hz}$ $I_{ab} = 20 \text{ mA}$
62.	Teletax distortion	THDTTX	CONV	-	-	3	%	5	$f = 16 \text{ kHz}$ $R_L = 200 \Omega$ $I_{ab} = 50 \text{ mA}$ $V_{ab,AC} = 2 \text{ Vrms}$
63.				-	-	3	%		$V_{ab,AC} = 5 \text{ Vrms}$ $I_{ab} = 0 \text{ mA},$ $V_{ab} = 55 \text{ V}$
64.				-	-	5	%		$V_{ab,AC} = 2 \text{ Vrms}$
65.	Psophometric noise	N_p, V_{ab}	CONV	-	-	- 75	dBmp	4	$I_{ab} = 30 \text{ mA}$
66.	Longitudinal to transversal rejection ratio V_{long}/V_{ab}	LTRR	CONV	61/58	-	-	dB	6	$V_{long} = 3 \text{ Vrms}$ $300 \text{ Hz} < f < 3.4 \text{ kHz}$ $I_{ab} = 30 \text{ mA}$
67.	Transversal to longitudinal rejection ratio V_{ab}/V_{long}	TLRR	CONV	50	-	-	dB	7	$V_{2W,AC} = 150 \text{ mVrms}$ $300 \text{ Hz} < f < 3.4 \text{ kHz}$ $I_{ab} = 30 \text{ mA}$

Electrical Characteristics

Table 8 (cont'd)

No.	Parameter	Symbol	Mode	Limit Values			Unit	Test Fig.	Test Condition
				min.	typ.	max. PEB/ PEF			
68.	Power supply rejection ratio V_{BAT}/V_{ab}	PSRR	CONV, BB	33	40	–	dB	4	300 Hz < f < 3.4 kHz $V_{Supply,AC} = 100$ mVp $I_{ab} = 30$ mA
69.	V_H/V_{ab}		PD	30/28	–	–	dB		
70.	V_{DD}/V_{ab}		BB	33/30	40	–	dB		
71.	V_{SS}/V_{ab}		CONV, BB	33	50	–	dB		
			CONV, BB	33	50 25	–	dB dB		
72.	Ringing voltage	V_{RING}	RING	67	–	–	Vrms, diff	8	$R_L = 1$ k Ω $C_L = 1$ μ F $f = 66$ Hz $V_{2W} = 1.7$ Vrms
73.	Ringing voltage with extended V_H			84	–	–	Vrms, diff	8	$V_H = 80$ V $f = 20$ Hz $V_{2W} = 2.2$ Vrms
74.	Ringing distortion	THD	RING	–	–	4	%	8	$f = 66$ Hz $V_{2W} = 1.7$ Vrms

Transversal Current Output I_T

75.	Transversal current ratio	Git	CONV, BB	33.89	33.98	34.07	dB	4	$V_{2W} = 50$ mVrms $f = 1015$ Hz $I_{ab} = 20$ mA
76.			CONV	33.89	33.98	34.07	dB		
77.	Gain flatness (guaranteed by design)	dGit	CONV, BB	– 0.05	–	0.05	dB	–	300 Hz < f < 3400 Hz $V_{2W,AC} = 50$ mVrms $I_{ab} = 20$ mA
78.	Gain tracking (guaranteed by design)	dGit	CONV	– 0.2	–	0.2	dB	–	3 dBm0 > V_{ab} > – 20 dBm0 $f = 1015$ Hz
79.	Total harmonic distortion V_{IT}	THD, I_T	CONV	–	0.01	0.3	%	4	$V_{2W,AC} = 50$ mVrms $f = 1015$ Hz $I_{ab} = 15$ mA

Electrical Characteristics

Table 8 (cont'd)

No.	Parameter	Symbol	Mode	Limit Values			Unit	Test Fig.	Test Condition
				min.	typ.	max. PEB/ PEF			
80.	Psophometric noise	N_p, V_{IT}	CONV	–	–	– 100 –97	dBmp	4	$I_{ab} = 30 \text{ mA}, T > 0^\circ\text{C}$ $-40^\circ\text{C} < T < 0^\circ\text{C}$
81.	Frequency response V_{IT}/V_{2W} (guaranteed by design) Amplitude	–	CONV	– 0.5	1.7	1.95	dB	4	$f = 200 \text{ kHz}$ $V_{2W,AC} = 50 \text{ mVrms}$ $I_{Line} = 20 \text{ mA}$ $C_s = 0.2 \text{ nF}$
82.	Phase			100	–	–	deg		
83.	Longitudinal to transversal current output rejection ratio V_{long}/V_{IT}	LITRR	CONV	75	–	–	dB	6	$V_{long} = 3 \text{ Vrms}$ $I_{ab} = 30 \text{ mA}$
84.				81	–	–	dB		$300 \text{ Hz} < f < 3.4 \text{ kHz}$ $f = 1015 \text{ Hz}$
85.	Power supply rejection ratio V_{BAT}/V_{IT}	PSRR	CONV, PD	50	60	–	dB	4	$300 \text{ Hz} < f < 3.4 \text{ kHz}$ $V_{supply,AC} = 100 \text{ mVp}$ $I_{ab} = 30 \text{ mA}$
86.	V_H/V_{IT}		BB	50	60	–	dB		
87.	V_{DD}/V_{IT}		CONV	50	60	–	dB		
88.	V_{SS}/V_{IT}		CONV	50	60	–	dB		

Electrical Characteristics

Table 9 External Elements in the Application Circuit (Figure 5)

Typical values are used in the test circuits, unless otherwise specified.

Ext. Part	Function	Typ. Value	Tolerance	Limit Values		Comment
				min.	max.	
R_1	Biasing, current reference	25 k Ω	–	–	50 k Ω	power dissipation increases with smaller R_1
R_2, R_3	I_T, I_L gain adjustment	1 k Ω	0.1% (rel.)	–	–	clipping for $I_T \times R_2 > 3\text{ V}$ or $I_L \times R_3 > 3\text{ V}$
R_S	Protection, isolation of capacitive load	50 Ω	0.1% (rel.)	30 Ω	–	–
R_5, R_6	Protection	50 Ω	0.1% (rel.)	–	–	–
C_1	C for the internal supply voltage filter	22 μF ($f_{3\text{dB}} \approx 3\text{ Hz}$)	20%	10 nF	–	$f_{3\text{dB}}$ increases with smaller C_1 , causing worse low frequency PSRR from V_{BAT}
C_S	Suppression of voltage spikes, frequency compensation	15 nF	5% (rel.)	200 pF	20 nF	–
C_2, C_3	$V_{\text{DD}}, V_{\text{SS}}$ supply voltage blocking	1 μF	20%	10 nF	–	$C_2, C_3 > 1\text{ }\mu\text{F}$ and $C_4 \approx C_5$ allows arbitrary switching sequence of all supply voltages incl.
C_4	V_H blocking	100 nF	–	–	–	
C_5	V_{BAT} blocking	100 nF	20%	100 nF	–	ground

Note: Exceeding the min./max. limits can cause stability problems!

Electrical Characteristics

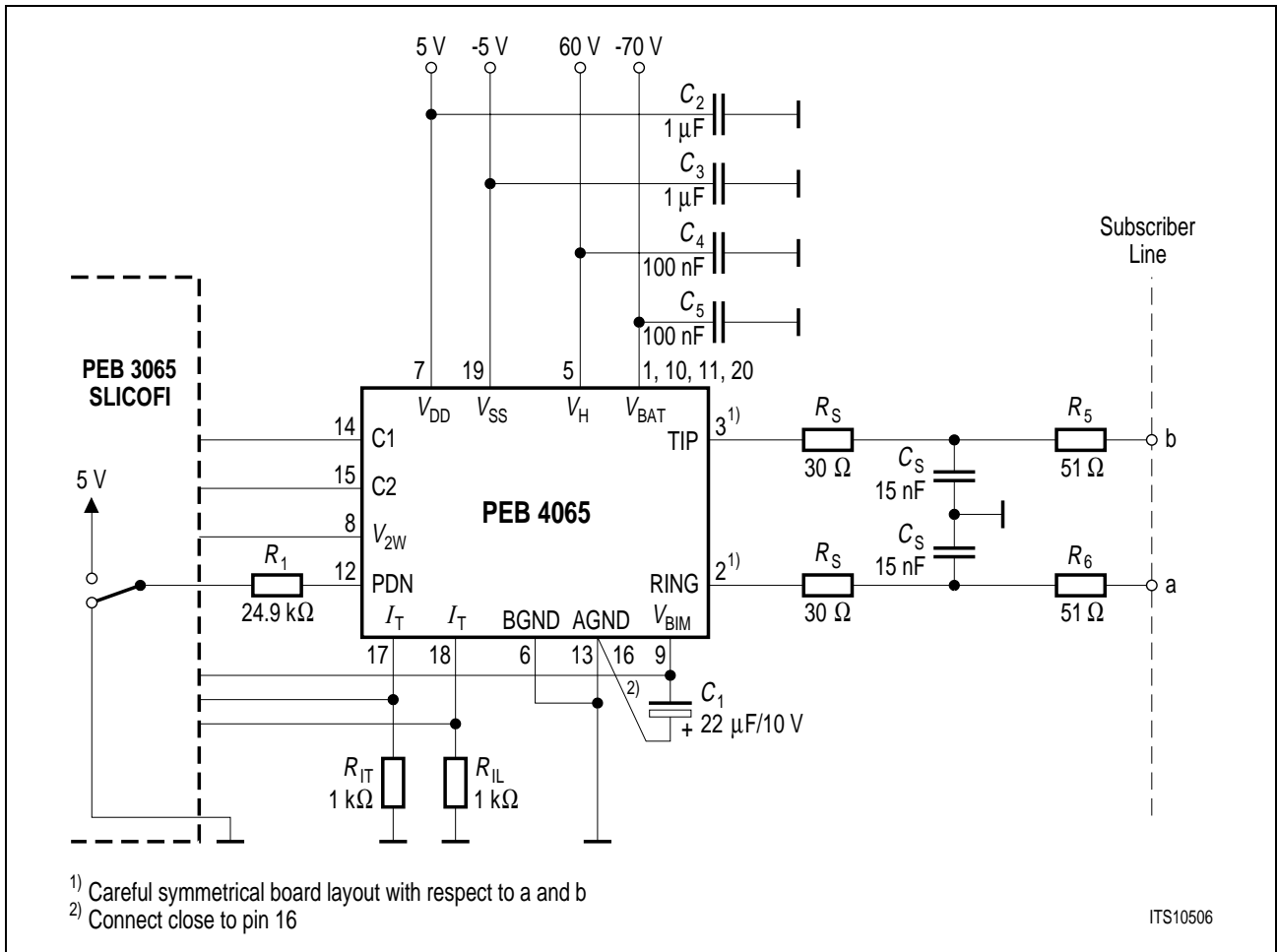
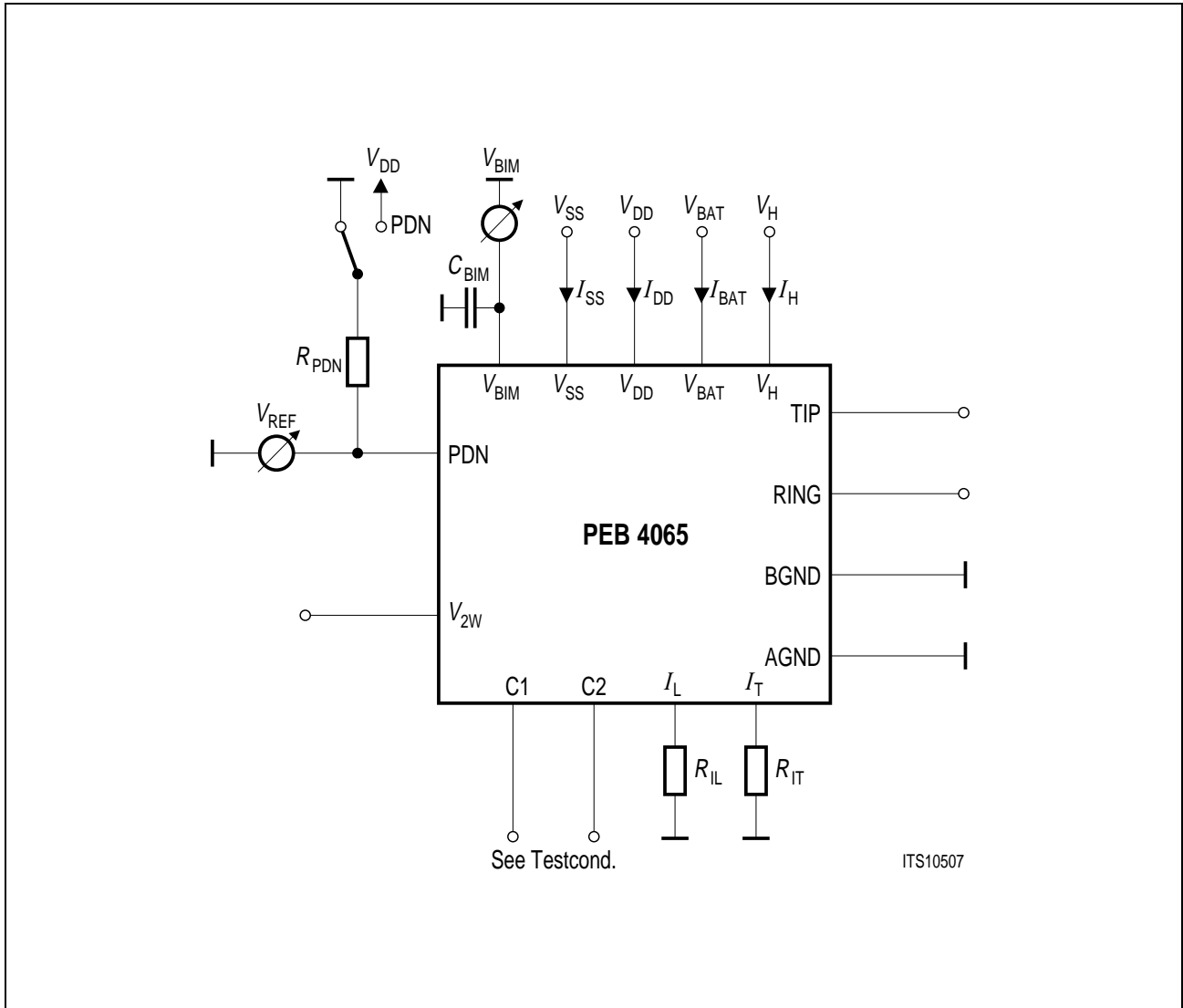

Figure 5 Application Circuit

Electrical Characteristics



Test Figure 1 DC Characteristics and Power Dissipation

Electrical Characteristics

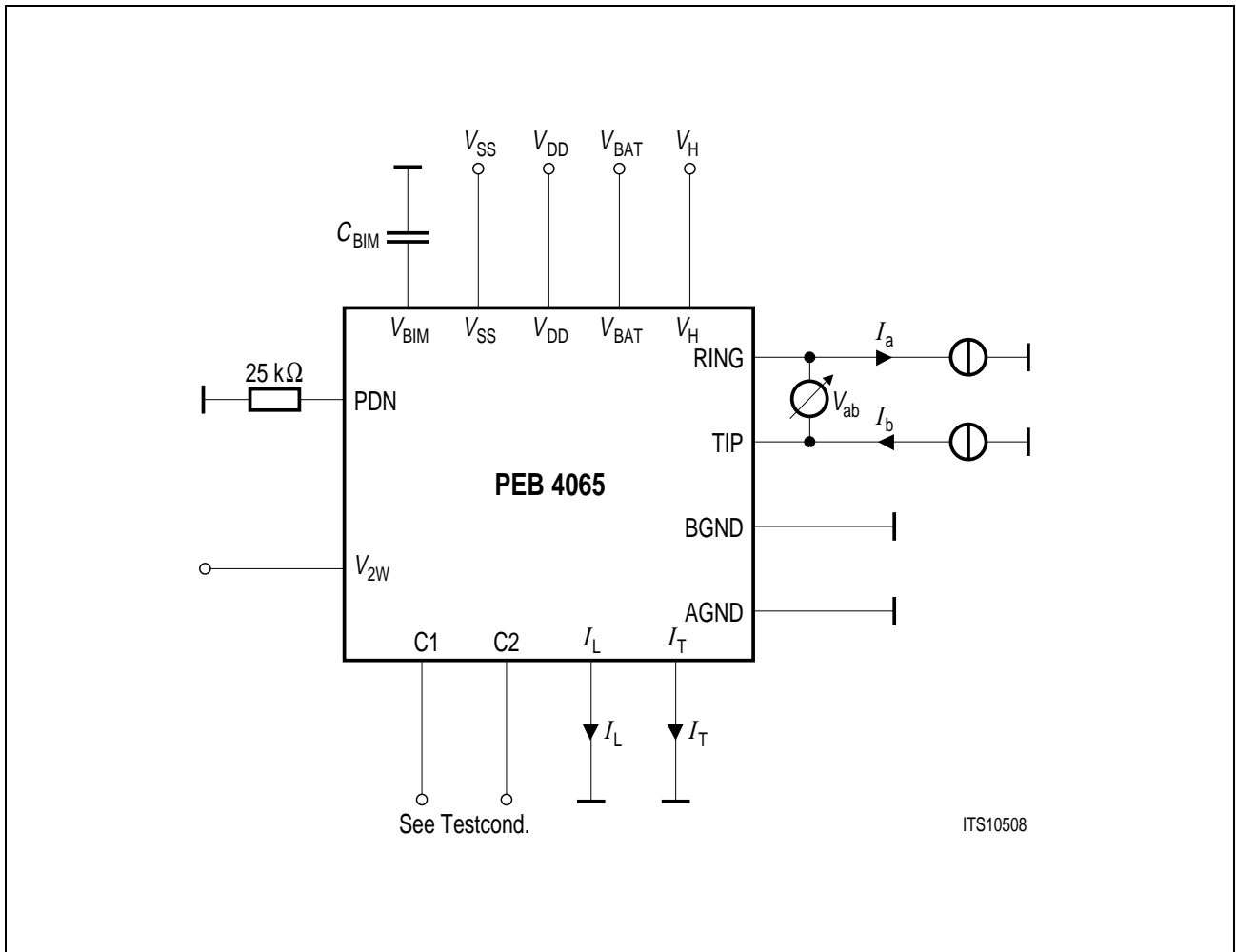

Test Figure 2 DC Line Voltage and Currents

Electrical Characteristics

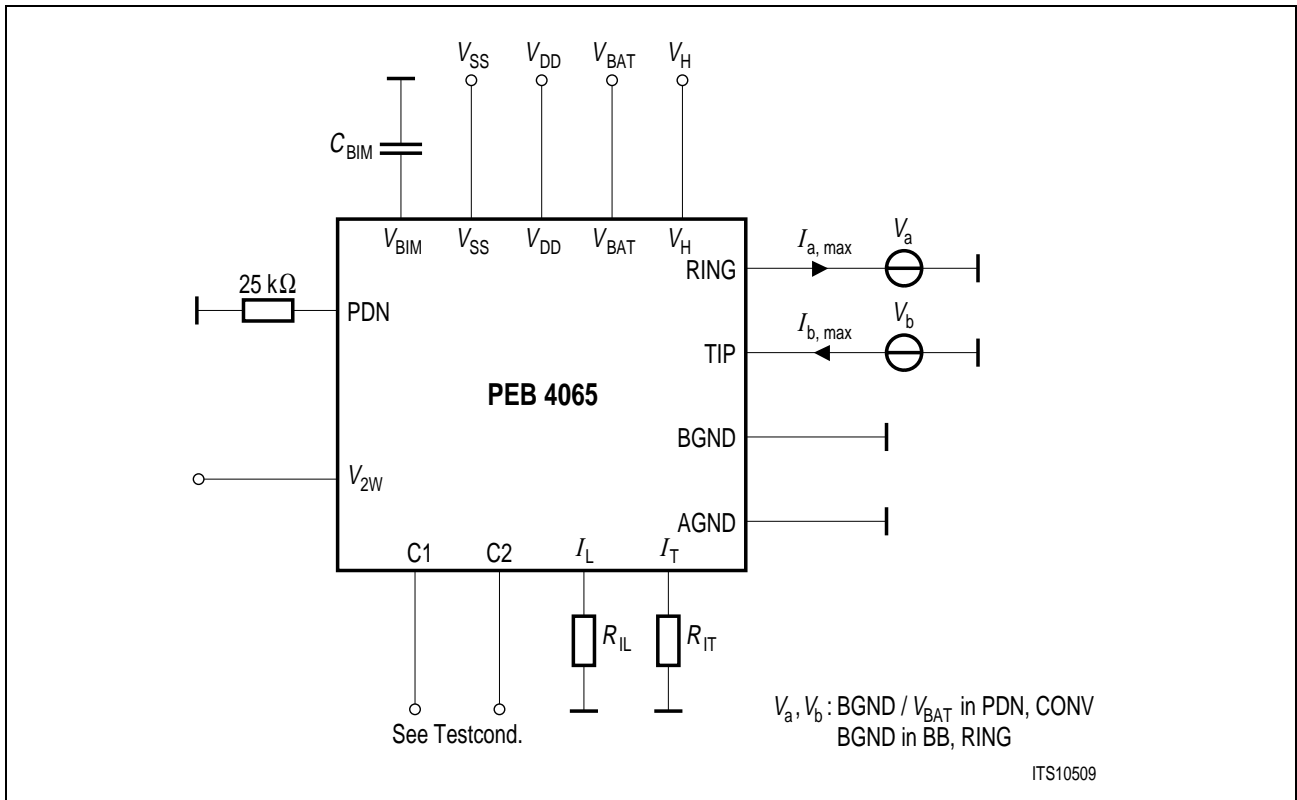

Test Figure 3 Output Current Limit

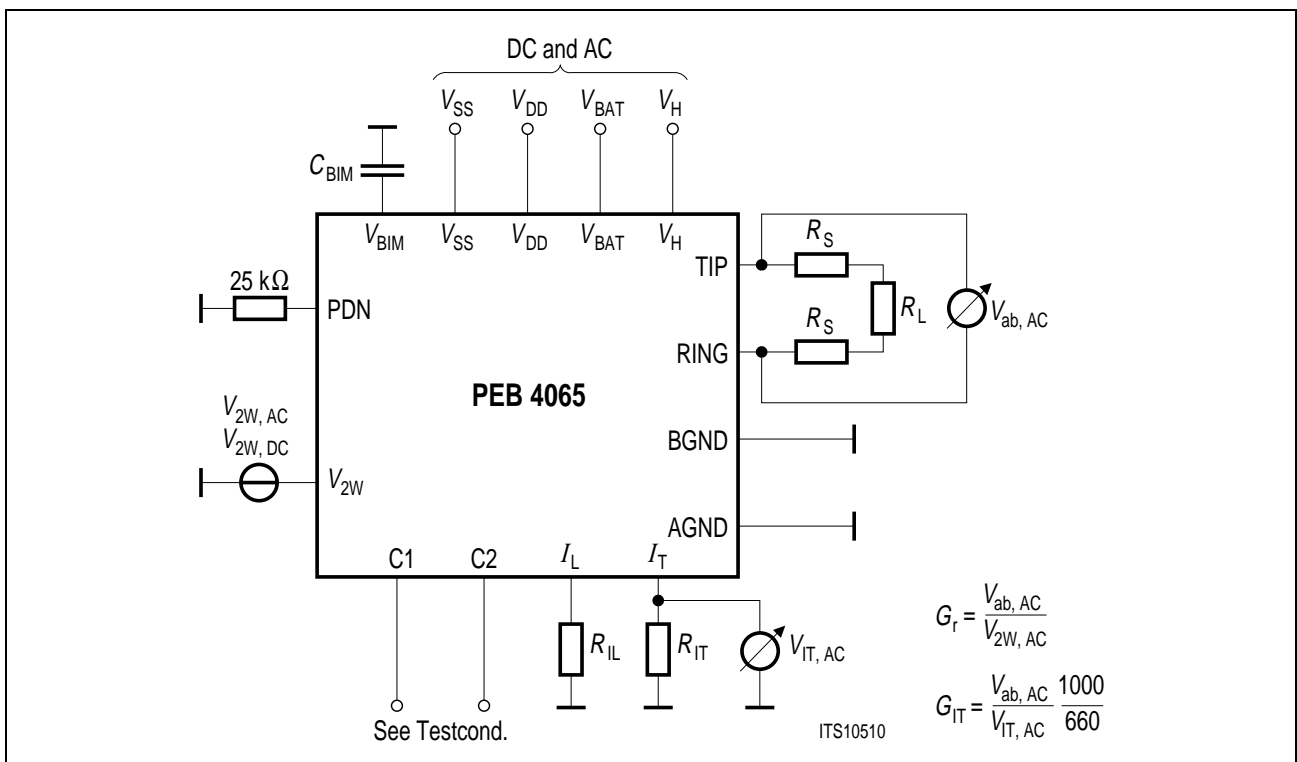

Test Figure 4 Receive Gain, Transversal Current Ratio, THD, Noise and Power Supply Rejection

Electrical Characteristics

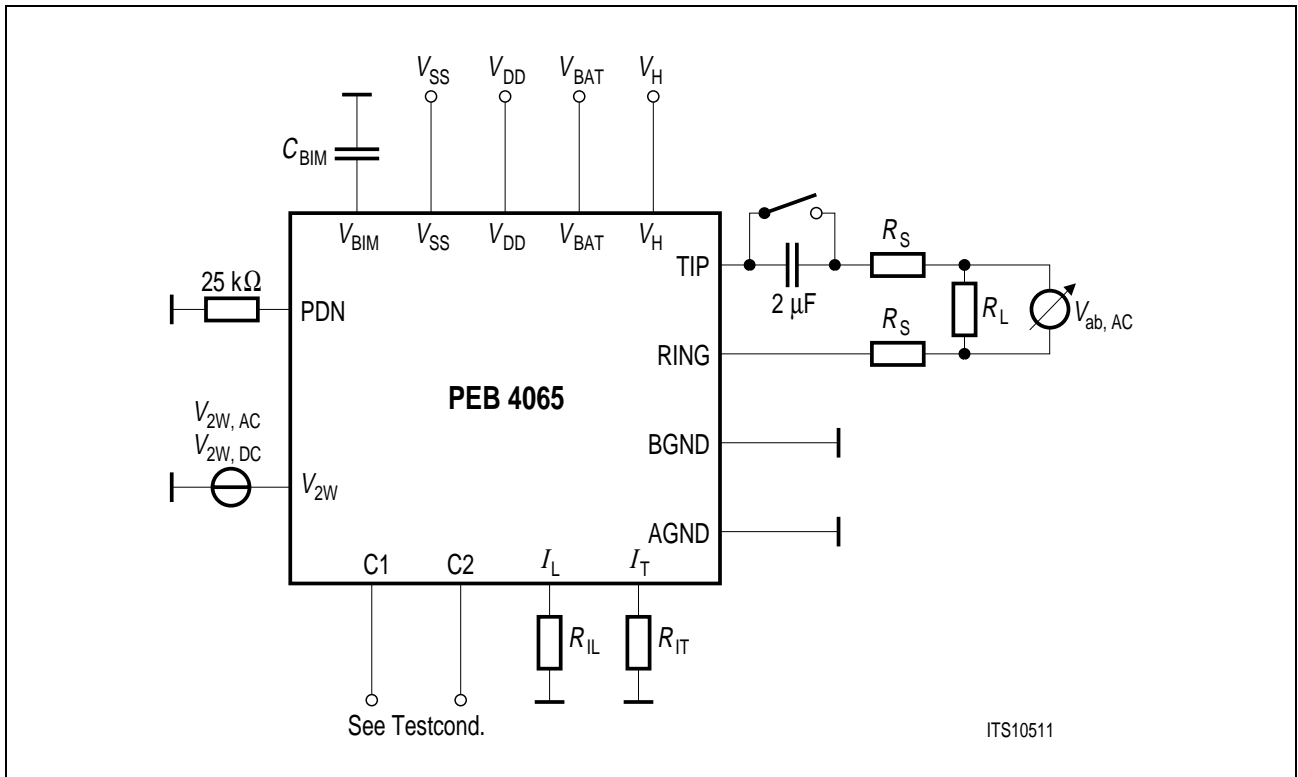

Test Figure 5 Teletax Distortion

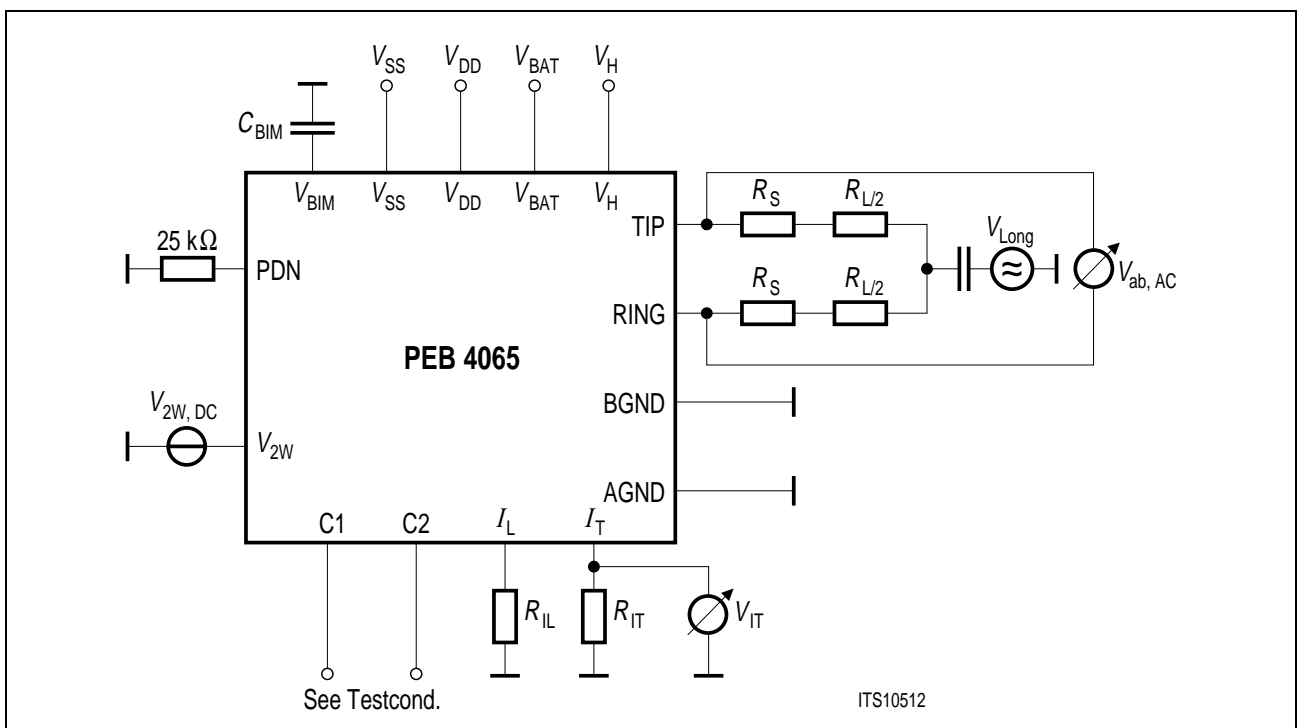

Test Figure 6 Longitudinal to Transversal Rejection Ratio

Electrical Characteristics

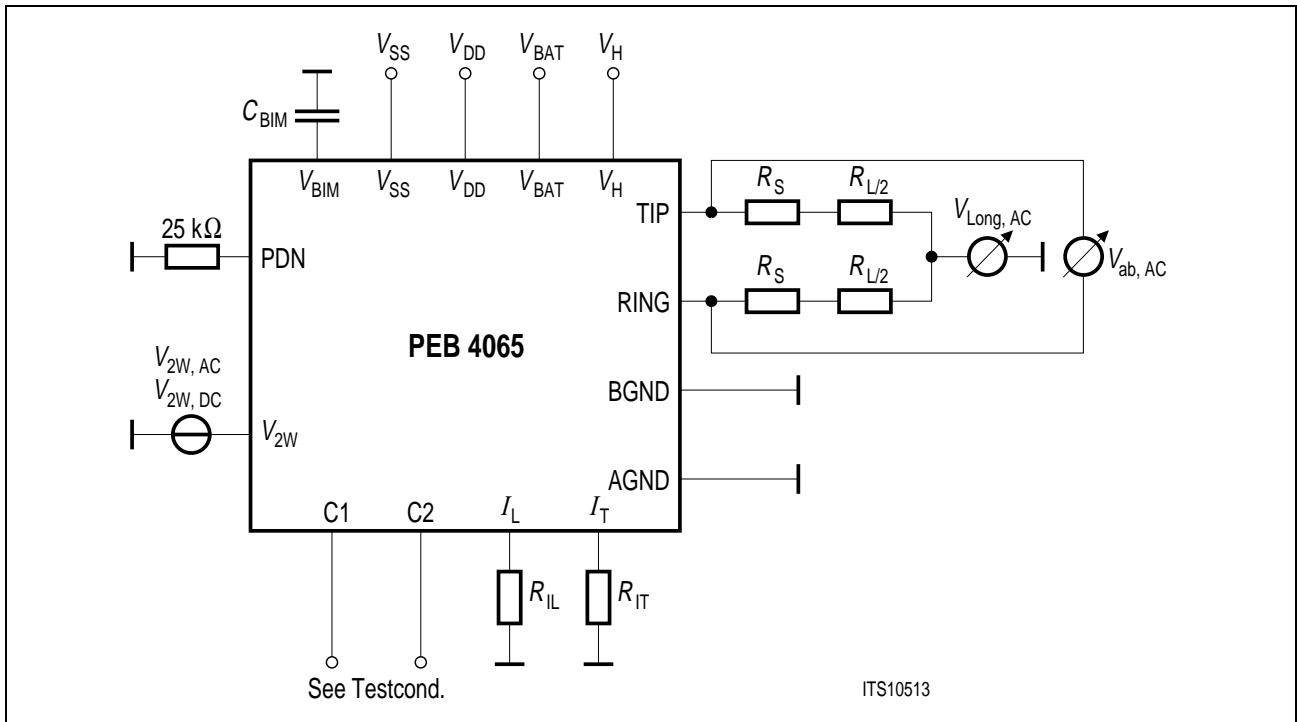

Test Figure 7 Transversal to Longitudinal Rejection Ratio

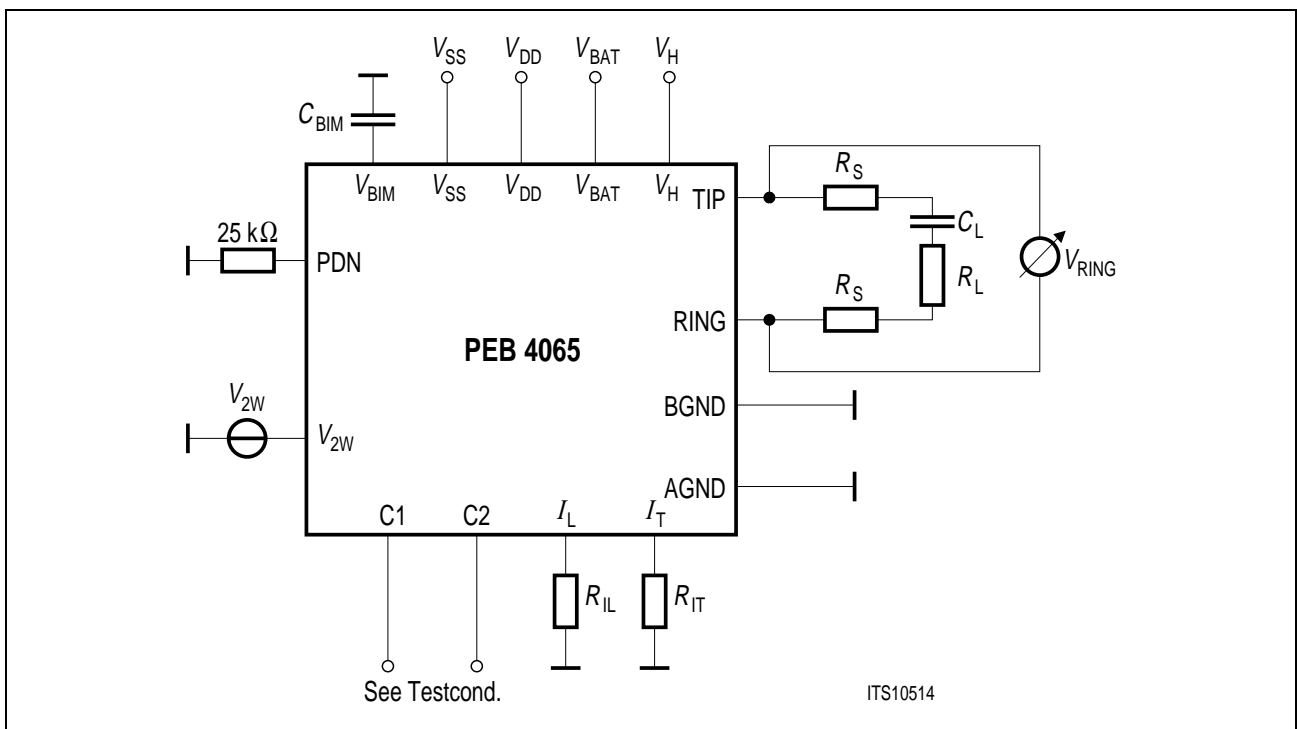

Test Figure 8 Ringing

Electrical Characteristics

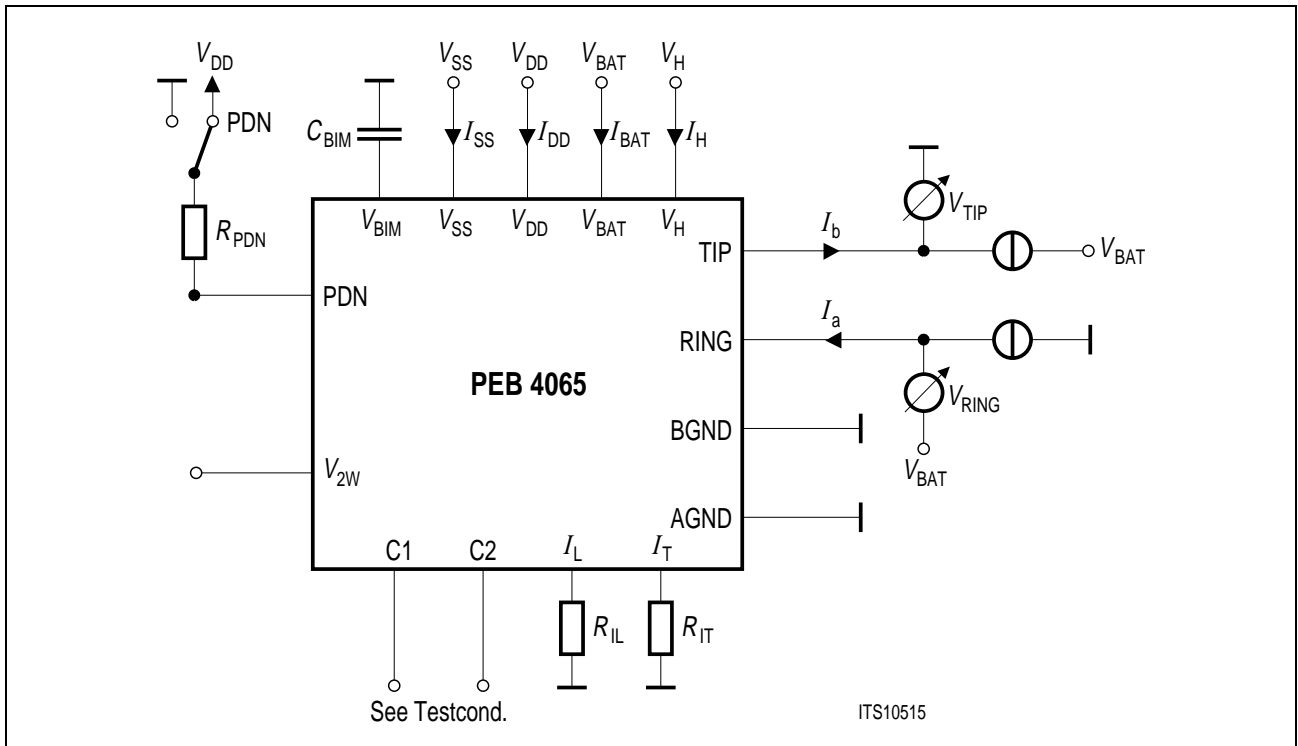

Test Figure 9 Output Resistance in PDNR Mode

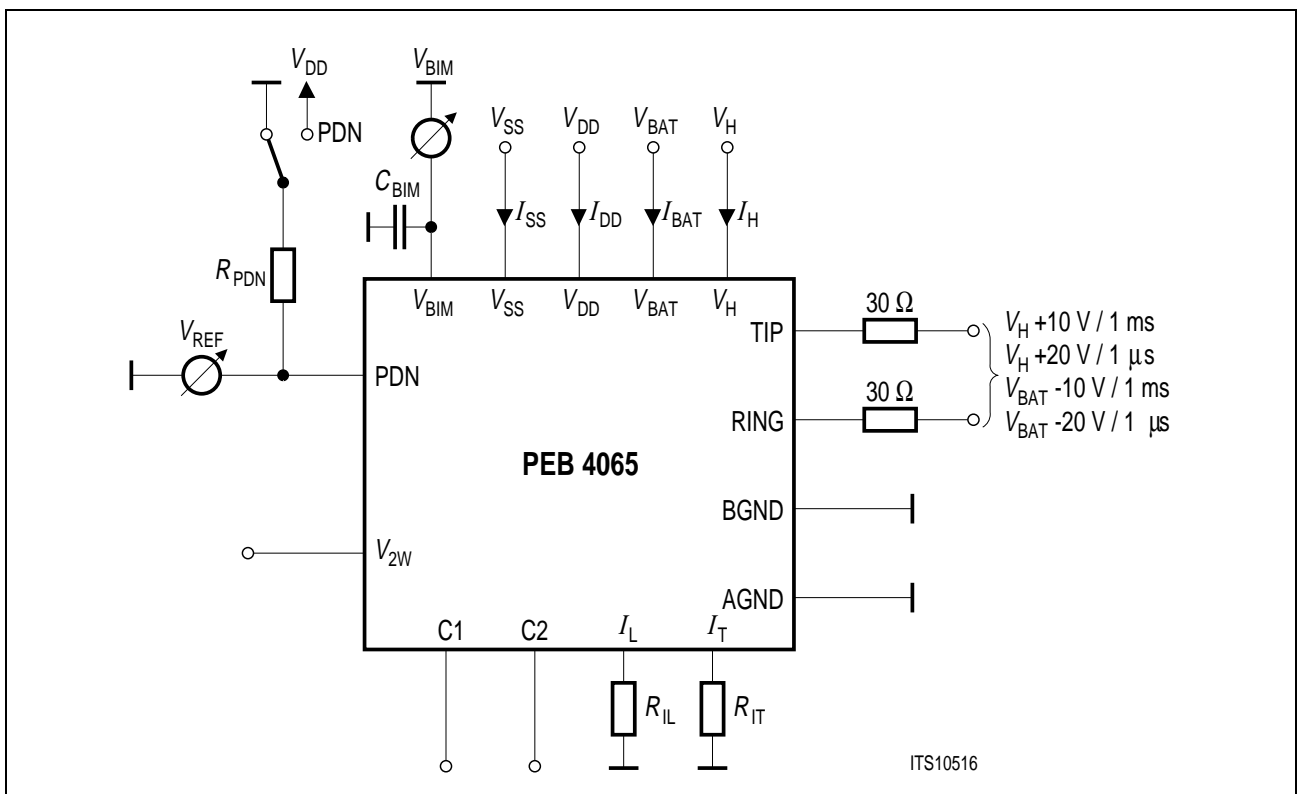

Test Figure 10 TIP, RING Overtoltage Pulses

3 Package Outlines

P-DSO-20-5
(Plastic Dual Small Outline Package)

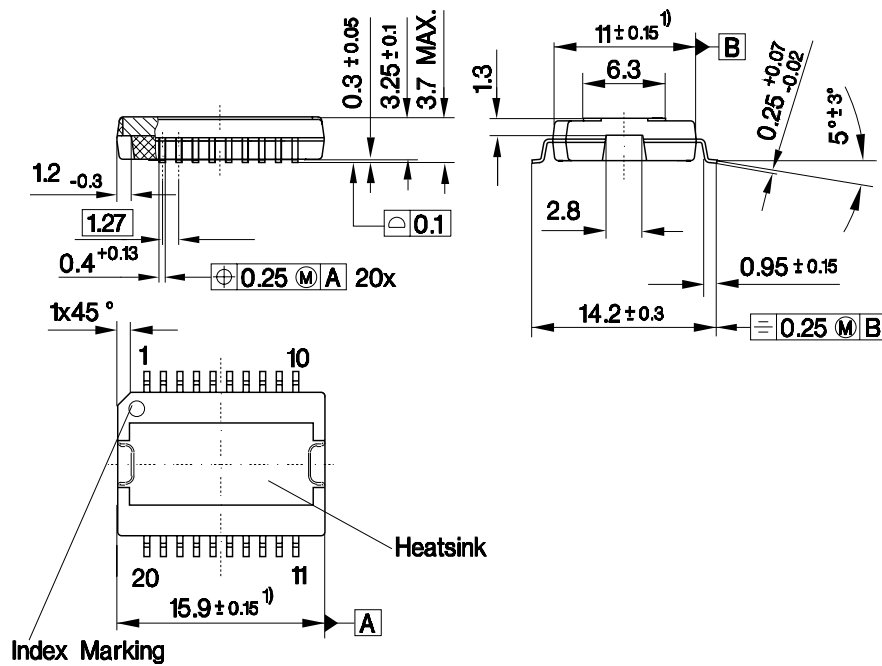

1) Does not include plastic or metal protrusion of 0.15 max. per side

GPS05755

Sorts of Packing

Package outlines for tubes, trays etc. are contained in our Data Book "Package Information".

SMD = Surface Mounted Device

Dimensions in mm