

SHINDENGEN

Super Fast Recovery Rectifiers

Dual

D20LC20U

200V 20A

FEATURES

Low noise
trr35ns
Fully Isolated Molding

APPLICATION

Switching power supply
Free Wheel
Home Appliances, Office Equipment,
Factory Automation

OUTLINE DIMENSIONS

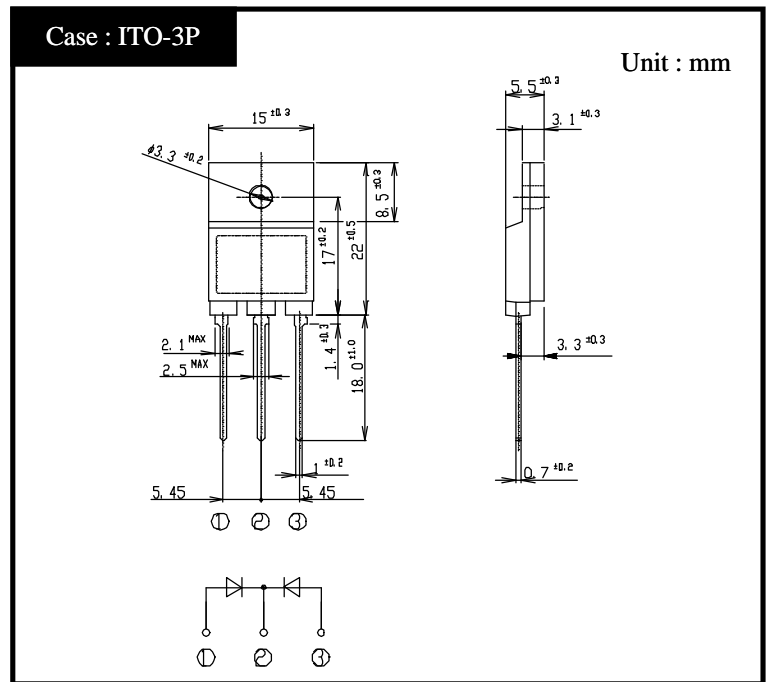

RATINGS

Absolute Maximum Ratings (If not specified Tc=25)

Item	Symbol	Conditions	Ratings	Unit
Storage Temperature	Tstg		-40 ~ 150	
Operating Junction Temperature	Tj		150	
Maximum Reverse Voltage	V _{RM}		200	V
Average Rectified Forward Current	I _O	50Hz sine wave, R-load, Rating for each diode I _O /2, Tc=112	20	A
Peak Surge Forward Current	I _{FSM}	50Hz sine wave, Non-repetitive 1 cycle peak value, Tj=25	150	A
Dielectric Strength	V _{dis}	Terminals to case, AC 1 minute	1.5	kV
Mounting Torque	TOR	(Recommended torque 0.5N·m)	0.8	N·m

Electrical Characteristics (If not specified Tc=25)

Item	Symbol	Conditions	Ratings	Unit
Forward Voltage	V _F	I _F =10A, Pulse measurement, Rating of per diode	Max.0.98	V
Reverse Current	I _R	V _R =V _{RM} , Pulse measurement, Rating of per diode	Max.10	μA
Reverse Recovery Time	trr	I _F =0.5A, I _R =1A, Rating of per diode	Max.35	ns
Thermal Resistance	jc	junction to case	Max.1.7	/W

D20LC20U Forward Voltage

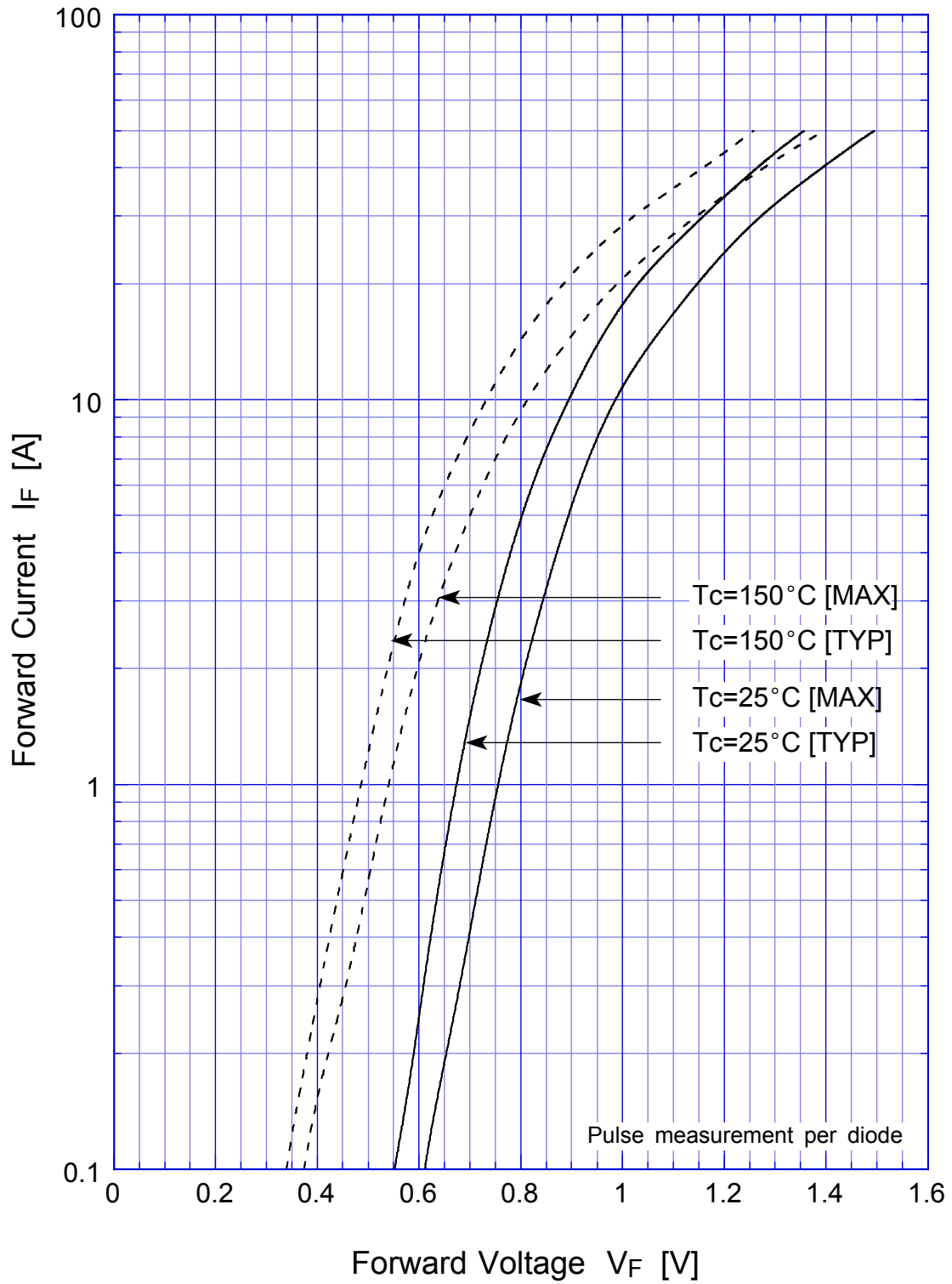

D20LC20U Forward Power Dissipation

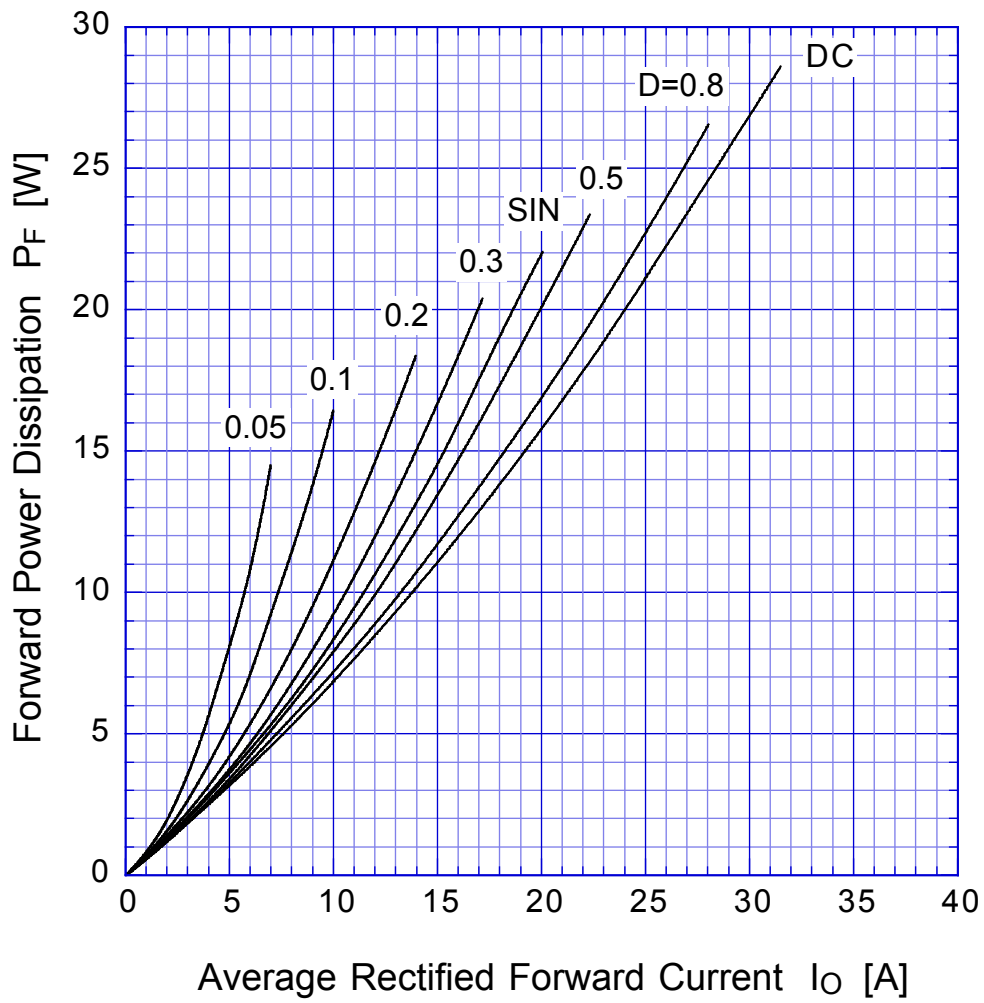

$T_j = T_{jmax}$



D20LC20U

Derating Curve

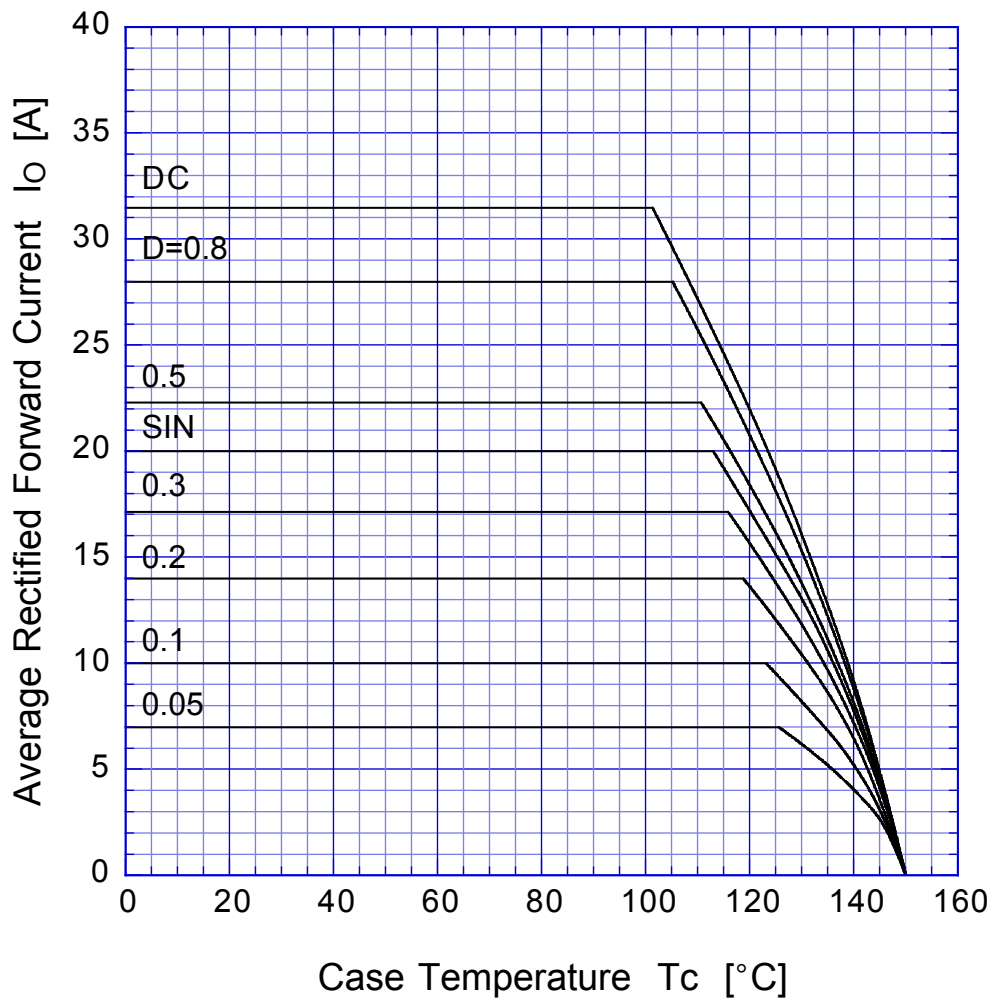

$$V_R = V_{RM}$$



D20LC20U Peak Surge Forward Capability

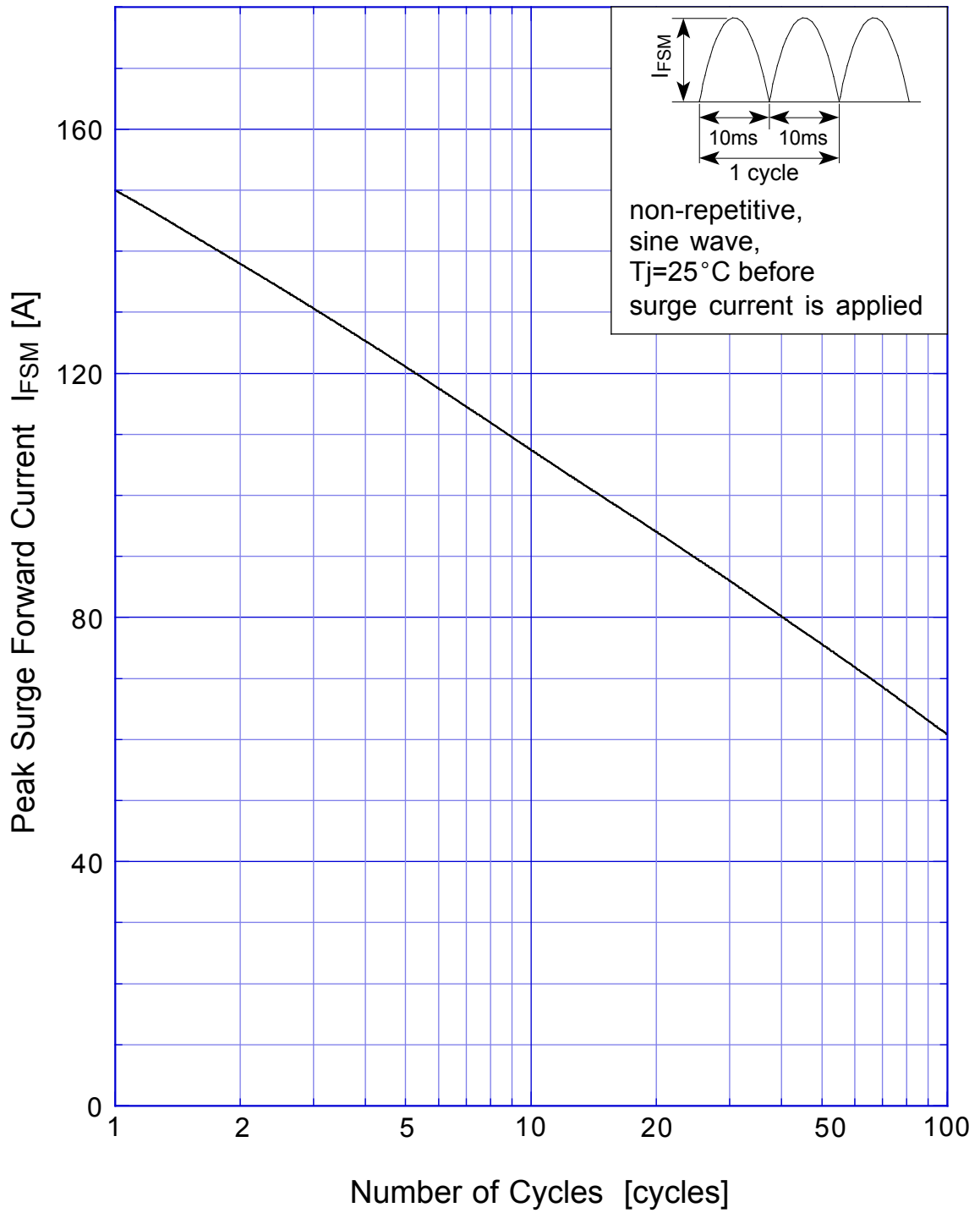

D20LC20U Junction Capacitance

