

**HID & SYSTEM MANAGEMENT PRODUCTS, MOUSECODER® FAMILY**
**PRELIMINARY**
**DESCRIPTION**

The SH1211 MouseCoder® is an easy-to-use single-chip multi-mouse encoder with an advanced motion algorithm for accurate cursor control. The SH1211 offers low power consumption in a small-footprint package, and connects to a host serial or a PS/2 mouse port.

The SH1211 is designed for use with a Fujitsu Takamisawa FID-828 Hall-effect sensor (HulaPoint™), a resistive analog joystick sensor (like the CTS 252), a switch joystick sensor, an FSR sensor, or a Varatouch MicroPoint™ sensor, as well as others.

The SH1211 provides an external port for hot-plug connection of a PS/2 mouse, including one with wheel function.

SH1211 serial communication is unidirectional at a fixed speed of 1200 Baud. PS/2 communication is bidirectional at 10 Kbps. The SH1211 is a CMOS device operating at 4 MHz. It can return mouse reports at the rate of 100 per second. The SH1211 is compatible with the standard two-button mouse protocol, the standard three-button mouse protocol, and standard wheel mouse protocols. It implements all commands from and to the system, as defined in the IBM PS/2 mouse communication protocol.

The SH1211's low power consumption makes it ideal for battery operated systems.

**FEATURES**

- Advanced motion-control algorithm for accurate cursor control
- Low power consumption in a 3.3 to 5.5 volt operating range
- Compatible with standard two-button, three-button, and wheel mice
- RS232 or PS/2 host interface
- Works with a Hall-effect sensor
- Works with a resistive analog joystick sensor
- Works with a switch joystick sensor
- Works with an FSR sensor
- Works with a Varatouch MicroPoint™ sensor
- Available in a small 32-pin plastic LQFP package

**APPLICATIONS**

- Embedded HulaPoints™
- Industrial panels
- Joystick applications
- Industrial keyboards
- Instrumentation
- Gaming

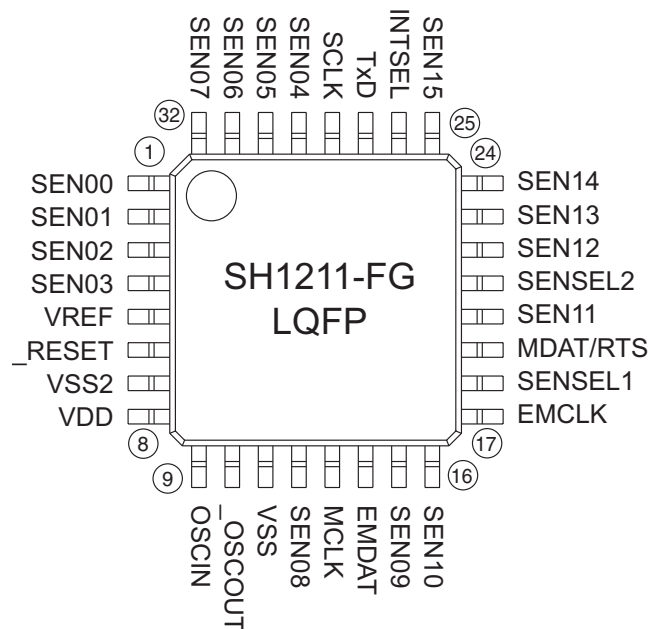
**PIN ASSIGNMENTS**

Semtech, the Semtech logo, MouseCoder, and HulaPoint are marks of Semtech Corporation. Force Sensing Resistor and FSR are marks of Interlink Electronics, Inc. MicroPoint is a mark of Varatouch Technology, Inc. All other marks belong to their respective owners.



**ORDERING CODE**

SH1211-FG LQFP 32-pin, 0.8 mm pitch, TA = -20°C to +85°C

EVK-SH1211 Evaluation kit

**FUNCTIONAL DESCRIPTION**

The SH1211 consists functionally of five major sections (see block diagram below). These are the Sensor Interface, the 16-bit Timer, the Oscillator Circuit, the PS/2 Communication Port and the RS232 Communication Port. All sections communicate with each other and operate concurrently.

**BLOCK DIAGRAM**

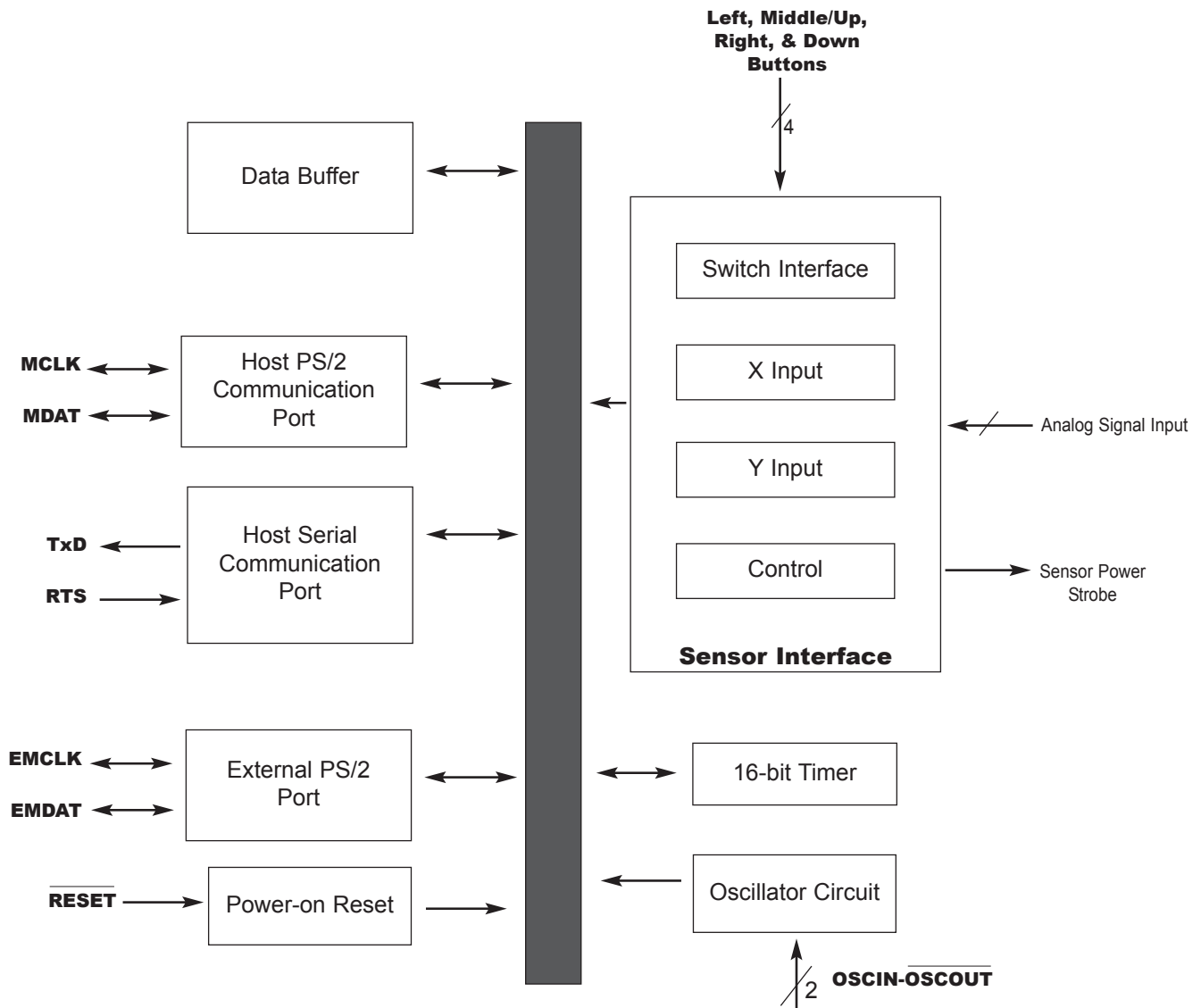



## MOUSE EMULATION

The SH1211 emulates either a standard 3-button mouse or a standard wheel mouse. The state of the button configuration pin (BCONF, pin 20) determines which mouse type is emulated. The pin left floating specifies 3-button mode, the pin tied to ground specifies wheel mode.

In 3-button mode, the left, right and middle buttons are implemented.

In wheel mode, the left, right, up, and down buttons are implemented; pressing up and down buttons together emulates a middle-button press.

## POWER CONSUMPTION

The SH1211 typically consumes less than 3 mA in standby for HulaPoint™ or analog joystick sensors and less than 1  $\mu$ A for other sensors.

## EXTERNAL PS/2 PORT

The SH1211 provides an external PS/2 mouse port. Data from this port is seamlessly merged with data from the embedded sensor. External mice, including those with a mouse wheel, can be hot-plug connected.

## HOST INTERFACE

The SH1211 communicates with the host system using either PS/2 or serial. The state of the interface select pin (INTSEL, pin 26) determines which interface is used. If the pin is tied to ground, PS/2 is used; if it is tied to power (Vcc), serial is used.

## SENSOR CONFIGURATIONS

The SH1211 has built-in support applicable to many sensors, including the following:

**HulaPoint™** Fujitsu Takamisawa FID-828 Hall-effect sensor

**Analog joystick sensor** such as the CTS 252

**Switch joystick sensor**

**FSR™ sensor** (Force Sensing Resistor™, Interlink Electronics)

**Varatouch MicroPoint™ sensor**

The states of the sensor select pins 18 and 21 (SENSEL1, SENSEL2) indicate which sensor is being used.

The name, definition and use of the 16 sensor pins (SEN00-SEN15: pins 1-4, 29-32, 15, 16, 20, 22-25) vary depending on which sensor is being used. Refer to the schematics and pin definitions in this data sheet for specifics.



## HULAPOINT™ & ANALOG

These pin descriptions and the schematic on the next page apply to a circuit with the Fujitsu Takamisawa FID-828 Hall-effect sensor (HulaPoint™) or an analog joystick sensor (like the CTS 252 resistive sensor).

With a HulaPoint™ or analog joystick sensor, the SH1211 supports wait mode and typically consumes less than 3 mA in standby.

See also the HulaPoint™ sensor orientation diagram toward the end of this data sheet.

## PIN DESCRIPTION NOTES

An underscore before a pin mnemonic denotes an active low signal.

### Pin types legend:

P = power

AI = analog input

I = input

O = output

I/O = input or output

I/O (nd) = input or output with N-channel open drain driver

The internal oscillator has a built-in feedback resistor. Only one external component is needed for clock generation. Semtech recommends a 4.00 MHz ceramic resonator with built-in load capacitors (AVX PBRC-4.00BR or equivalent).

The button inputs (pins 22-25) have built-in pull-up resistors. No additional components are required. However, if high levels of ESD and EMI are expected, then series protection resistors (47 Ohms to 1K Ohms) are recommended between the switches and the switch inputs on the SH1211.

## PINS FOR HULAPOINT™ & ANALOG JOYSTICK SENSOR CIRCUITS

### Pin Numbers

Mnemonic	Pin	Type	Name and Function
<b>Power</b>			
VDD	8	P	Power supply: +5V
VSS2, VSS	7, 11	P	Ground
<b>Reset</b>			
_RESET	6	I	Reset: apply 0V for orderly start-up
<b>Oscillator</b>			
OSCIN	9	I	Oscillator input: external clock input or one side of the ceramic resonator with built-in load capacitors
_OSCOU	10	O	Oscillator output: open for external clock input or one side of the ceramic resonator with built-in load capacitors
<b>Host</b>			
INTSEL	26	I	Host interface select: tie to ground for PS/2 host, tie to power (VCC) for serial host
MCLK	13	I/O (nd)	Host PS/2 clock
MDAT/RTS	19	I/O (nd)	Host PS/2 data / serial ready-to-send
TxD	27	O	Serial transmit to host: idle high; in serial mode, connect to host Rx/D; in PS/2 mode, leave floating
<b>External PS/2</b>			
EMCLK	17	I/O (nd)	External mouse clock: PS/2 clock signal from external mouse
EMDAT	14	I/O (nd)	External mouse data: PS/2 data signal from external mouse
<b>Select</b>			
SENSEL1-2	18, 21	I	Sensor select; for HulaPoint™ or analog joystick, leave both floating
<b>Reference</b>			
VREF	5	AI	Reference voltage for built-in A/D: for HulaPoint sensor, connect to SPWR0
<b>Sensor</b>			
SEN00-3 /SWPWR0-3	1-4	I/O	Switched power drivers; connect together
SEN04-5 /SWPWR4-5	29, 30	I/O	Switched power driver; connect to SWPWR0
SEN06/YAD	31	AI	Y-axis analog to digital converter input
SEN07/XAD	32	AI	X-axis analog to digital converter input
SEN08/_XYSWP	12	I	Leave floating for default X, Y axes; connect to ground to swap X and Y axes
SEN09/_XINV	15	I	Leave floating for default X direction; connect to ground for reversed X direction
SEN10/_YINV	16	I	Leave floating for default Y direction; connect to ground for reversed Y direction
SEN11/BCONF	20	I	Button configuration: leave floating for standard 3-button mouse mode, tie to ground for up/down/wheel-mouse mode
SEN12/_DB	22	I/O (nd)	Down button: active low, strobed sampling
SEN13/_LB	23	I/O (nd)	Left button: active low, strobed sampling
SEN14/_MB/_UE	24	I/O (nd)	Middle button: active low, strobed sampling
SEN15/_RB	25	I/O (nd)	Right button: active low, strobed sampling
<b>Reserved</b>			
RSVD	28		Leave floating

## SCHEMATIC FOR THE SH1211 MOUSECODER® WITH ANALOG JOYSTICK SENSOR

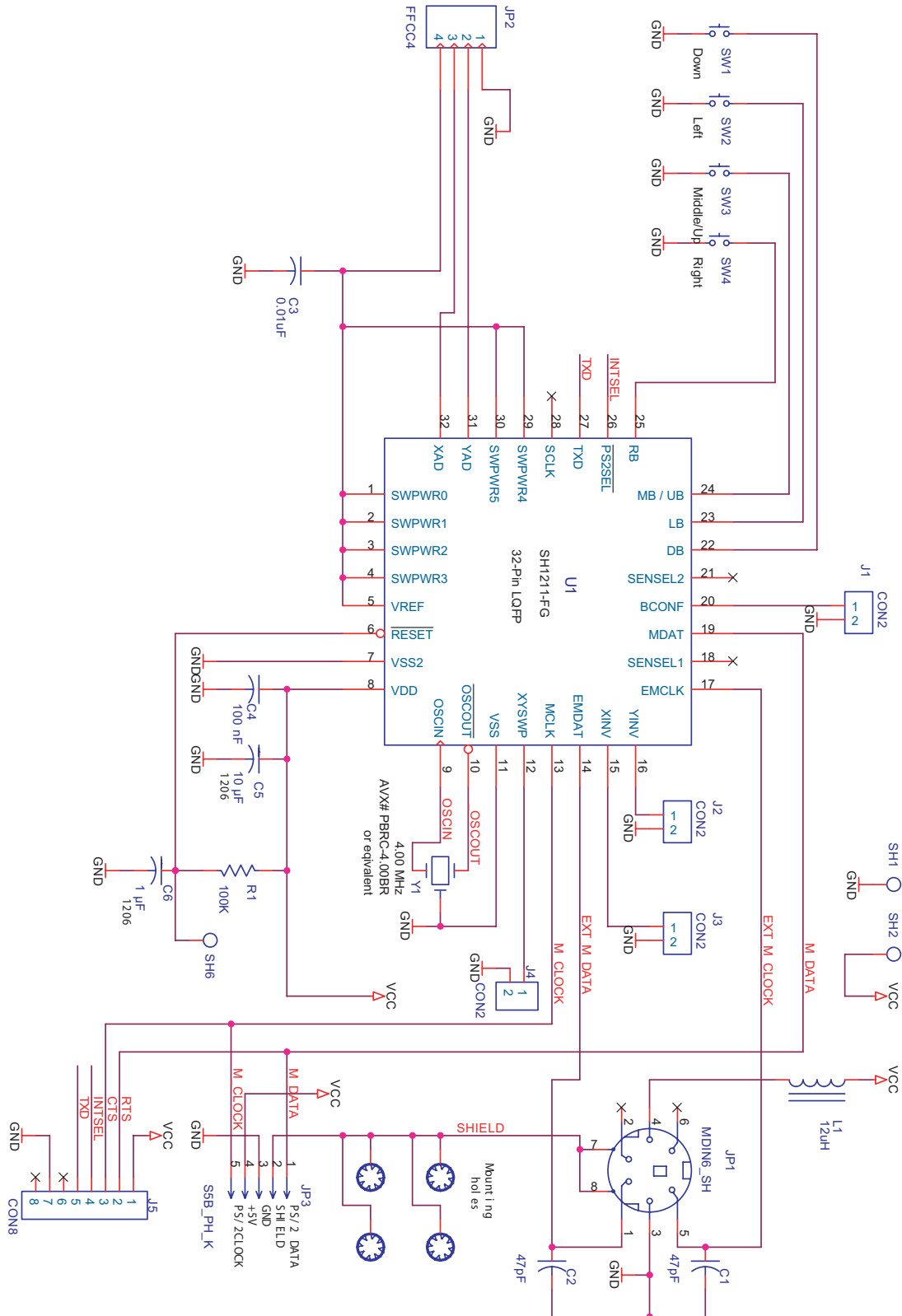



## FSR™ SENSOR

These pin descriptions and the schematic on the next page apply to a circuit with an Interlink Electronics Force Sensing Resistor™ (FSR™) sensor.

With an FSR sensor, the SH1211 supports stop mode and typically consumes less than 1  $\mu$ A in standby.

## PIN DESCRIPTION NOTES

An underscore before a pin mnemonic denotes an active low signal.

### Pin types legend:

P = power

AI = analog input

I = input

O = output

I/O = input or output

I/O (nd) = input or output with  
N-channel open drain driver

The internal oscillator has a built-in feedback resistor. Only one external component is needed for clock generation. Semtech recommends a 4.00 MHz ceramic resonator with built-in load capacitors (AVX PBRC-4.00BR or equivalent).

The button inputs (pins 22-25) have built-in pull-up resistors. No additional components are required. However, if high levels of ESD and EMI are expected, then series protection resistors (47 Ohms to 1K Ohms) are recommended between the switches and the switch inputs on the SH1211.

## PINS FOR FSR™ SENSOR CIRCUITS

### Pin Numbers

Mnemonic	Pin	Type	Name and Function
<b>Power</b>			
V <sub>DD</sub>	8	P	Power supply: +5V
V <sub>SS2</sub> , V <sub>SS</sub>	7, 11	P	Ground
<b>Reset</b>			
<u>RESET</u>	6	I	Reset: apply 0V for orderly start-up
<b>Oscillator</b>			
OSCIN	9	I	Oscillator input: external clock input or one side of the ceramic resonator with built-in load capacitors
<u>OSCOU</u>	10	O	Oscillator output: open for external clock input or one side of the ceramic resonator with built-in load capacitors
<b>Host</b>			
INTSEL	26	I	Host interface select: tie to ground for PS/2 host, tie to power (V <sub>CC</sub> ) for serial host
MCLK	13	I/O (nd)	Host PS/2 clock
MDAT/RTS	19	I/O (nd)	Host PS/2 data / serial ready-to-send
TxD	27	O	Serial transmit to host: idle high; in serial mode, connect to host Rx/D; in PS/2 mode, leave floating
<b>External PS/2</b>			
EMCLK	17	I/O (nd)	External mouse clock: PS/2 clock signal from external mouse
EMDAT	14	I/O (nd)	External mouse data: PS/2 data signal from external mouse
<b>Select</b>			
SENSEL1-2	18, 21	I	Sensor select; for FSR sensor, tie SESEL1 to ground and leave SENSEL2 floating
<b>Reference</b>			
VREF	5	AI	Reference voltage for built-in A/D: for FSR sensor, connect to V <sub>DD</sub>
<b>Sensor</b>			
SEN00/FSR_E	1	I/O	East
SEN01/FSR_N	2	I/O	North
SEN02/FSR_W	3	I/O	West
SEN03/FSR_S	4	I/O	South
SEN04, SEN07-SEN10	29, 32, 12, 15, 16	I/O	Reserved, leave floating
SEN05/TOUCH	30	AI	Touch
SEN06/SENSE	31	AI	Sense
SEN11/BCONF	20	I	Button configuration: leave floating for standard 3-button mouse mode, tie to ground for up/down/wheel-mouse mode
SEN12/_DB	22	I/O (nd)	Down button: active low, strobed sampling
SEN13/_LB	23	I/O (nd)	Left button: active low, strobed sampling
SEN14/_MB/_UE	24	I/O (nd)	Middle button: active low, strobed sampling
SEN15/_RB	25	I/O (nd)	Right button: active low, strobed sampling
<b>Reserved</b>			
RSVD	28		Reserved, leave floating

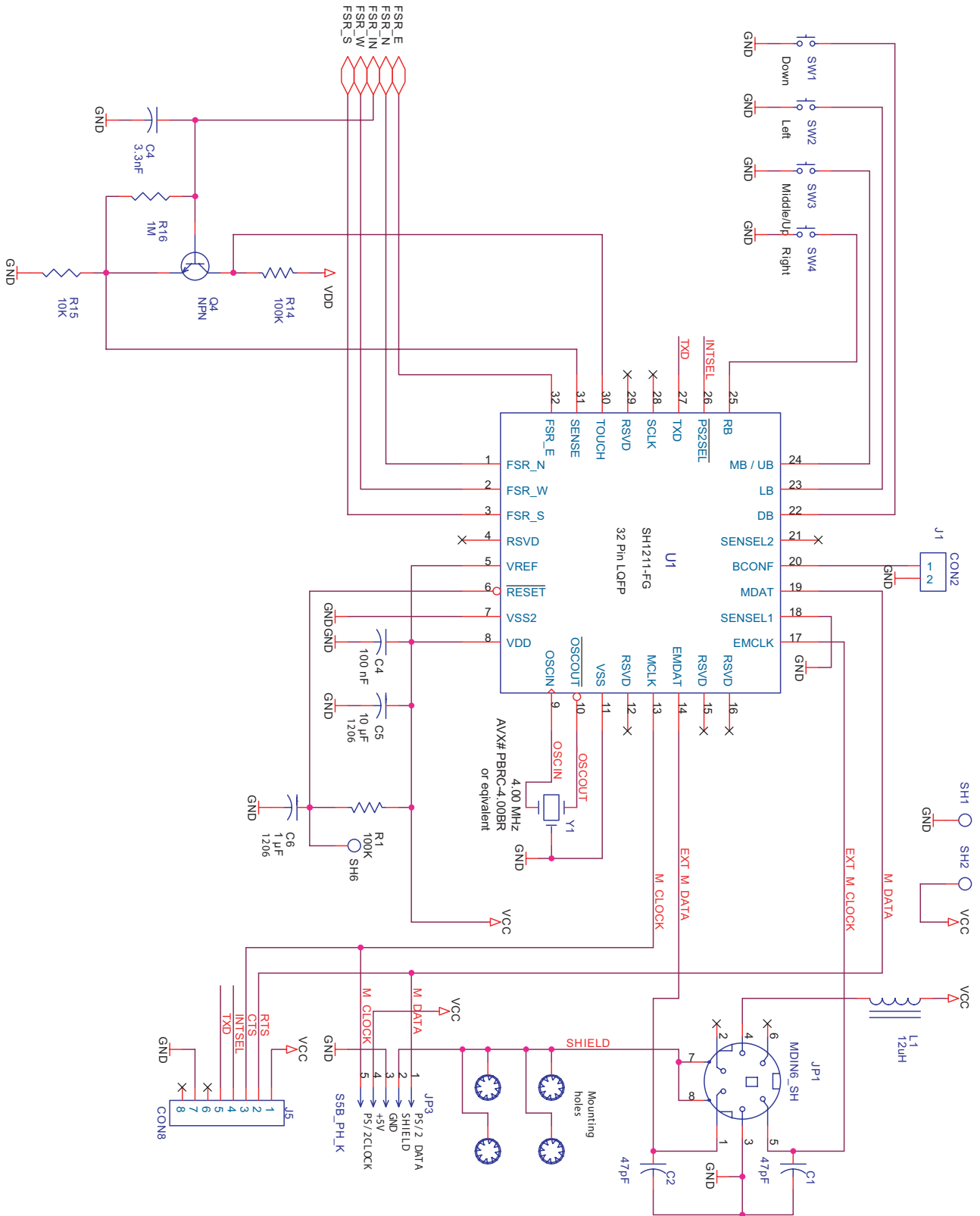
**SCHEMATIC FOR THE SH1211 MOUSECODER® WITH FSR™ SENSOR**



## SWITCH JOYSTICK SENSOR

These pin descriptions and the schematic on the next page apply to a circuit with a switch joystick sensor.

With a switch joystick sensor, the SH1211 supports stop mode and typically consumes less than 1  $\mu$ A in standby.

## PIN DESCRIPTION NOTES

An underscore before a pin mnemonic denotes an active low signal.

### Pin types legend:

P = power

AI = analog input

I = input

O = output

I/O = input or output

I/O (nd) = input or output with  
N-channel open drain driver

The internal oscillator has a built-in feedback resistor. Only one external component is needed for clock generation. Semtech recommends a 4.00 MHz ceramic resonator with built-in load capacitors (AVX PBRC-4.00BR or equivalent).

Direction switched and button switches share the same center contact pad. All sensor lines are connected to the SH1211 with no extra parts.

## PINS FOR SWITCH JOYSTICK SENSOR CIRCUITS

### Pin Numbers

Mnemonic	Pin	Type	Name and Function
<b>Power</b>			
VDD	8	P	Power supply: +5V
VSS2, VSS	7, 11	P	Ground
<b>Reset</b>			
_RESET	6	I	Reset: apply 0V for orderly start-up
<b>Oscillator</b>			
OSCIN	9	I	Oscillator input: external clock input or one side of the ceramic resonator with built-in load capacitors
_OSCOU	10	O	Oscillator output: open for external clock input or one side of the ceramic resonator with built-in load capacitors
<b>Host</b>			
_INTSEL	26	I	Host interface select: tie to ground for PS/2 host, tie to power (Vcc) for serial host
MCLK	13	I/O (nd)	Host PS/2 clock
MDAT/RTS	19	I/O (nd)	Host PS/2 data / serial ready-to-send
TxD	27	O	Serial transmit to host: idle high; in serial mode, connect to host RxD; in PS/2 mode, leave floating
<b>External PS/2</b>			
EMCLK	17	I/O (nd)	External mouse clock: PS/2 clock signal from external mouse
EMDAT	14	I/O (nd)	External mouse data: PS/2 data signal from external mouse
<b>Select</b>			
SENSEL1-2	18, 21	I	Sensor select; for switch sensor, tie both to ground
<b>Reference</b>			
VREF	5	AI	Reference voltage for built-in A/D: for switch sensor, connect to VDD
<b>Sensor</b>			
SEN00/BT_N	1	I/O	Connect to north contact pad
SEN01/BT_NE	2	I/O	Connect to northeast contact pad
SEN02/BT_E	3	I/O	Connect to east contact pad
SEN03/BT_SE	4	I/O	Connect to southeast contact pad
SEN04/BT_S	29	I/O	Connect to south contact pad
SEN05/BT_SW	30	I/O	Connect to southwest contact pad
SEN06/BT_W	31	I/O	Connect to west contact pad
SEN07/BT_NW	32	I/O	Connect to northwest contact pad
SEN08/ BT_CENTER	12	I/O (nd)	Connect to center contact pad, works as tap button
SEN09/BT_L	15	I/O (nd)	Left button
SEN10/BT_R	16	I/O (nd)	Right button
SEN11 /BT_COMMON	20	I	Connect to common contact pad
SEN12-15	22, 23, 24, 25		Reserved, leave floating
<b>Reserved</b>			
RSVD	28		Leave floating



**SCHEMATIC FOR THE SH1211 MOUSECODER® WITH SWITCH JOYSTICK SENSOR**

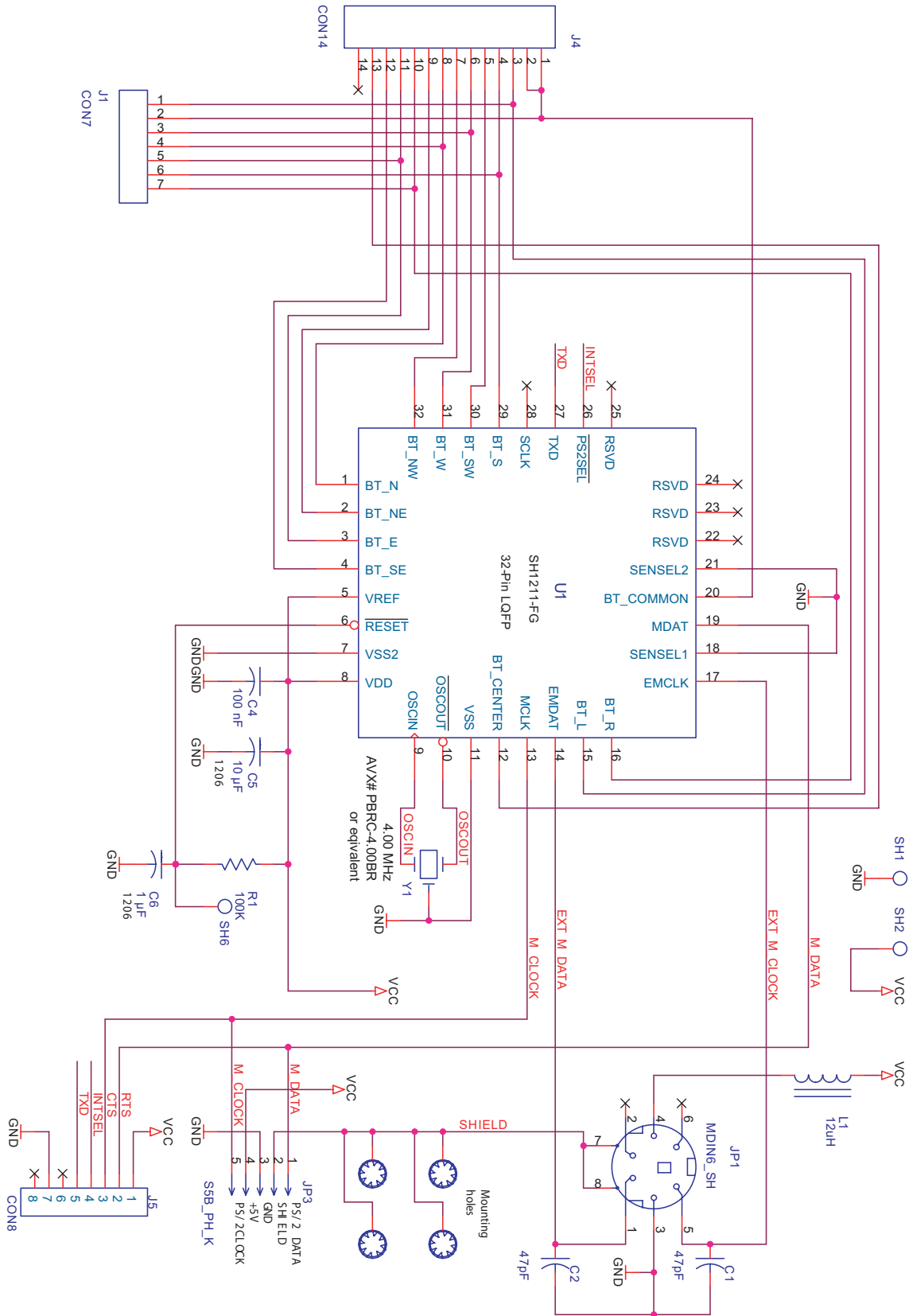



## MICROPOINT™ SENSOR

These pin descriptions and the schematic on the next page apply to a circuit with a Varatouch MicroPoint™ sensor.

With a Varatouch MicroPoint™ sensor, the SH1211 supports stop mode and typically consumes less than 1  $\mu$ A in standby.

## PIN DESCRIPTION NOTES

An underscore before a pin mnemonic denotes an active low signal.

### Pin types legend:

P = power

AI = analog input

I = input

O = output

I/O = input or output

I/O (nd) = input or output with N-channel open drain driver

The internal oscillator has a built-in feedback resistor. Only one external component is needed for clock generation. Semtech recommends a 4.00 MHz ceramic resonator with built-in load capacitors (AVX PBRC-4.00BR or equivalent).

The button inputs (pins 22-25) have built-in pull-up resistors. No additional components are required. However, if high levels of ESD and EMI are expected, then series protection resistors (47 Ohms to 1K Ohms) are recommended between the switches and the switch inputs on the SH1211.

## PINS FOR MICROPOINT™ SENSOR CIRCUITS

### Pin Numbers

Mnemonic	Pin	Type	Name and Function
<b>Power</b>			
V <sub>DD</sub>	8	P	Power supply: +5V
V <sub>SS2</sub> , V <sub>SS</sub>	7, 11	P	Ground
<b>Reset</b>			
_RESET	6	I	Reset: apply 0V for orderly start-up
<b>Oscillator</b>			
OSCIN	9	I	Oscillator input: external clock input or one side of the ceramic resonator with built-in load capacitors
_OSCOU	10	O	Oscillator output: open for external clock input or one side of the ceramic resonator with built-in load capacitors
<b>Host</b>			
_INTSEL	26	I	Host interface select: tie to ground for PS/2 host, tie to power (V <sub>CC</sub> ) for serial host
MCLK	13	I/O (nd)	Host PS/2 clock
MDAT/RTS	19	I/O (nd)	Host PS/2 data / serial ready-to-send
TxD	27	O	Serial transmit to host: idle high; in serial mode, connect to host Rx/D; in PS/2 mode, leave floating
<b>External PS/2</b>			
EMCLK	17	I/O (nd)	External mouse clock: PS/2 clock signal from external mouse
EMDAT	14	I/O (nd)	External mouse data: PS/2 data signal from external mouse
<b>Select</b>			
SENSEL1-2	18, 21	I	Sensor select; for MicroPoint™ sensor, leave SENSEL1 floating and tie SENSEL2 to ground
<b>Reference</b>			
VREF	5	AI	Reference voltage for built-in A/D: for MicroPoint™ sensor, connect to V <sub>DD</sub>
<b>Sensor</b>			
SEN00/SOUTH	1	I/O	West
SEN01/NORTH	2	I/O	South
SEN02/EAST	3	I/O	North
SEN03/RSVD	4		Reserved, leave floating
SEN04/ PUPDRV	29	I/O	Pull-up driver: connect to Touch and Sense through a 500 KOhm resistor
SEN05/TOUCH	30	AI	Touch
SEN06/SENSE	31	AI	Sense
SEN07/WEST	32	I/O	West
SEN08-09	12, 15	I/O	Reserved, leave floating
SEN10/SWITCH	16	I/O	Switch
SEN11/BCONF	20	I	Button configuration: leave floating for standard 3-button mouse mode, tie to ground for up/down/wheel-mouse mode
SEN12/ DB	22	I/O (nd)	Down button: active low, strobed sampling
SEN13/ LB	23	I/O (nd)	Left button: active low, strobed sampling
SEN14/ MB/ UE	24	I/O (nd)	Middle button: active low, strobed sampling
SEN15/ RB	25	I/O (nd)	Right button: active low, strobed sampling
<b>Reserved</b>			
RSVD	28		Reserved, leave floating

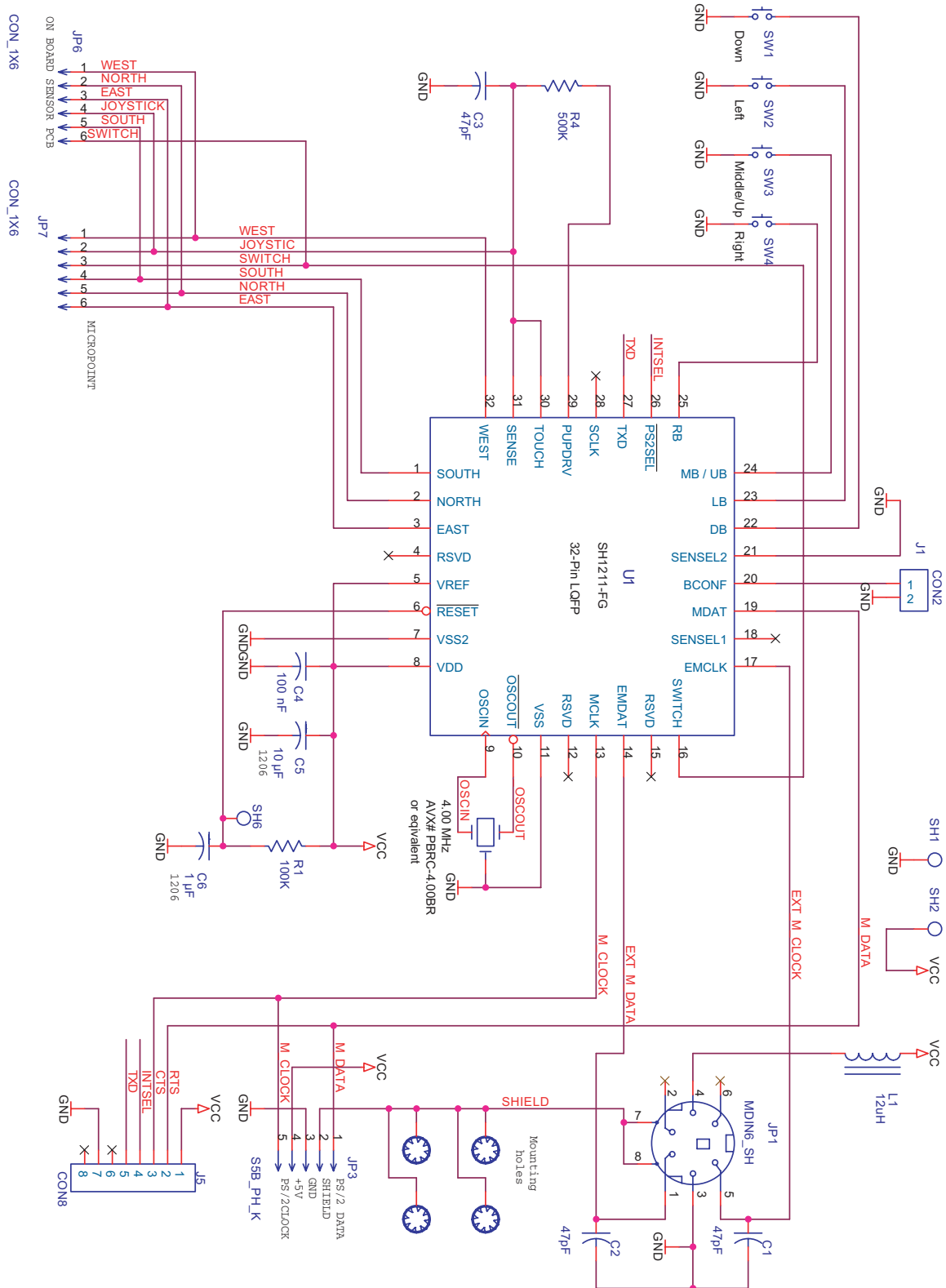
**SCHEMATIC FOR THE SH1211 MOUSECODER® WITH VARATOUGH MICROPPOINT™ SENSOR**



## SERIAL HARDWARE

The TxD and RTS lines are CMOS logic-level signals, suitable for direct connection to the pins of an UART. Interfacing via the RS-232 port requires an addition of an inverting driver and receiver.

## SERIAL COMMUNICATION

Communication through the serial port is uni-directional at a fixed speed of 1200 Baud, 7N1 protocol (7 data bits, 1 stop bit, no parity check).

The host can reset the device at any time by setting the RTS line high. When RTS is set low after a delay of at least 100 ms, the SH1211 responds with two identification characters. The SH1211's response depends on its mode, wheel mode or 3-button mode, as determined by the state of the button configuration pin (BCONF, pin 20).

### Wheel mode

If the SH1211 is in wheel mode, then when RTS is set low after a delay of at least 100 ms, the SH1211 responds with the two identification characters "MZ" (0x4D, 0x5A); they are followed by a zero motion report consisting of the four bytes 0x40, 0x00, 0x00, 0x00, and then by the plug-and-play string:

(vvSTH1211\MOUSE\PNP0F0A\HULAcc)

This plug-and-play string is a sequence of ASCII characters with their codes reduced by 0x20. Note that vv represents a 2-byte version number, and cc is a 2-byte checksum. For further information, please refer to the Microsoft *Plug and Play External COM Device Specification*:

<http://www.microsoft.com/hwdev/resources/specs/pnpcom.asp>

### 3-button mode

If the SH1211 is in 3-button mode, then when RTS is set low after a delay of at least 100 ms, the SH1211 responds with the two identification characters "M3" (0x4D, 0x33); they are followed by a zero motion report consisting of the four bytes 0x40, 0x00, 0x00, 0x00, and then by the plug-and-play string:

(vvSTH1211\MOUSE\PNP0F0A\HULAcc)

This plug-and-play string is a sequence of ASCII characters with their codes reduced by 0x20. Note that vv represents a 2-byte version number, and cc is a 2-byte checksum. For further information, please refer to the Microsoft *Plug and Play External COM Device Specification*:

<http://www.microsoft.com/hwdev/resources/specs/pnpcom.asp>



## SERIAL COMMUNICATION (CONT'D)

In wheel mode, data reports are always four bytes long.

In 3-button mode, data reports are four bytes long only if the middle button is depressed or changing state; otherwise, data reports are three bytes long.

A data report is sent if motion is detected, or if buttons are pressed or released. X and Y motion is reported relative to the last report sent, in a two's complement form with 8-bit resolution. Therefore, motion values range from -128 to +127.

Z3-Z0 is Z-displacement (wheel value), a 4-bit two's complement value ranging from -8 to +7.

## SERIAL DATA REPORT

### Byte 1

b0	X6
b1	X7: MSB of X Data
b2	Y6
b3	Y7: MSB of Y Data
b4	Right button status, 1 = depressed
b5	Left button status, 1 = depressed
b6	Always=1

### Byte 2

b0	X0: LSB of X data
b1	X1
b2	X2
b3	X3
b4	X4
b5	X5
b6	Always=0

### Byte 3

b0	Y0: LSB of Y data
b1	Y1
b2	Y2
b3	Y3
b4	Y4
b5	Y5
b6	Always=0

### Byte 4 (wheel mode)

b0	Z0: LSB of Z data
b1	Z1
b2	Z2
b3	Z3: MSB of Z data
b4	Middle button status; 1=depressed
b5	Always=0
b6	Always=0

### Byte 4 (3-button mode, only when middle button is depressed or changing state)

b0	Always=0
b1	Always=0
b2	Always=0
b3	Always=0
b4	Always=0
b5	Middle button status; 1=depressed
b6	Always=0



## PS/2 COMMUNICATION

At start-up or reset, the SH1211 waits up to 500 milliseconds, then sends 0xAA to the host, followed by a device ID of 0x00. Then the SH1211 sets itself to its default values: incremental stream mode with 1:1 scaling, and a report rate of 100 Hz. The SH1211 then disables itself until a command is received from the host.

## PS/2 REPORTS

The adjacent list shows the PS/2 report formats.

In the data report, each of the two position values (X and Y) is expressed as a 9-bit two's complement integer with the most significant bit (the sign bit) stored separately in byte 1. Z value (wheel or scroll) is expressed as an 8-bit two's complement integer.

If there is an overflow of the accumulator, the maximum positive or negative count is reported and the corresponding overflow bit is set.

## PS/2 ERROR HANDLING

For every correct command or parameter received from the host, the SH1211 sends an acknowledge (0xFA). If an invalid command or parameter is received, the SH1211 issues a resend request (0xFE). If an invalid input is again received, the device transmits an error code (0xFC) to the host. Both error and resend request responses are sent by the device within 25 milliseconds. The host may not issue any new commands until either the SH1211 has responded or 25 milliseconds have elapsed.

## PS/2 DATA REPORT

Byte 1		
b0	Left Button status	1 = depressed
b1	Right Button Status	1 = depressed
b2	Middle Button Status	1 = depressed
b3	Reserved	Always = 1
b4	X8: MSB of X data, sign bit	1 = negative
b5	Y8: MSB of Y data, sign bit	1 = negative
b6	X data overflow	1 = overflow
b7	Y data overflow	1 = overflow
Byte 2		
b0	X0: LSB of X data	
b1	X1	
b2	X2	
b3	X3	
b4	X4	
b5	X5	
b6	X6	
b7	X7	
Byte 3		
b0	Y0: LSB of Y data	
b1	Y1	
b2	Y2	
b3	Y3	
b4	Y4	
b5	Y5	
b6	Y6	
b7	Y7	
Byte 4 (for wheel function; sent only if output of Z data is enabled by the driver)		
b0	Z0: LSB of Z data	
b1	Z1	
b2	Z2	
b3	Z3	
b4	Z4	
b5	Z5	
b6	Z6	
b7	Z7: MSB of Z data, sign bit	

## PS/2 STATUS REPORT

Byte 1		
b0	Right button	1 = depressed
b1	Middle button	1 = depressed
b2	Left button	1 = depressed
b3	Reserved	Always = 0
b4	Scaling - 1:1 (0) / 2:1 (1)	
b5	Disable - (0) / enable (1)	
b6	Stream - (0) / prompt (1) mode	
b7		Always = 0
Byte 2		
b0 - 1	Current resolution setting	
b2 - 7		Always = 0
Byte 3		
b0-7	Current sampling rate	

## COMMANDS FROM PS/2 HOST

The **Set Default Status Command (0xF6)** re-initializes the device to its condition at power-up.

When the **Reset Command (0xFF)** is received, the SH1211 sets the following default parameters: incremental stream mode, 1:1 scaling, report rate of 100 Hz, and disabled. It then sends 0xAA to the host followed by a device ID of 0x00.

The host sends the **Resend Last Data Stream Command (0xFE)** when it detects an error in any SH1211 transmission. The device then resends the last output data packet to the host. This transmission occurs after a SH1211 transmission, and before the host enables the interface allowing the next SH1211 output.

The **Disable Command (0xF5)** stops the device from transmitting all reports. However, the mode does not change; the SH1211 is still able to respond to commands. If the disable command is issued while the device is transmitting a report, the SH1211 immediately stops the transmission and disables itself.

The **Reset Echo Mode Command (0xEC)** returns the device to its previous mode, and is disabled.

The **Set Prompt (Remote) Mode Command (0xF0)** sets the device to Prompt Mode. Data values are then only reported in response to a **Read Report Command (0xEB)**.

If the **Set Echo Mode Command (0xEE)** is received, the SH1211 immediately returns any data bytes except 0xFF or 0xEC.

If the SH1211 is in incremental stream mode, the **Enable Command (0xF4)** allows it to begin data transmission. If the device is in prompt mode, the enable command only updates the internal status of the SH1211.

The SH1211 responds to the **Set Sampling Rate Command (0xF3)** in both stream and prompt modes but only updates its internal status if this command is enacted while the device is in stream mode.

The SH1211 responds to the **Read Device Type Command (0xF2)** with the device ID of 0x00.

The **Read Report Command (0xEB)** prompts the SH1211 for a report. The report occurs even if the device has not moved or if the status of the switches did not change.

The **Set Incremental Stream Mode Command (0xEA)** sets the SH1211 to stream mode and disables the device.

The **Status Request Command (0xE9)** returns a 3-byte status report.

The **Set Resolution Command (0xE8)** controls resolution, the **Set 2:1 Scaling Command (0xE7)** enables a coarse/fine tracking response, and the **Set 1:1 Scaling Command (0xE6)** enables the values of movements to be transmitted to the host without any scaling. Due to Semtech's advanced motion algorithm, set resolution and scaling commands are acknowledged and reported as activated, but their contents are ignored.

**HULAPOINT™ SENSOR ORIENTATION**

The SH1211 has three pins that determine sensor orientation- X-invert (XINV, pin 15), Y-invert (YINV, pin 16), and XY swap (XYSWP, pin 12)- allowing eight orientation schemes. The diagrams below show two of these orientation schemes, using the HulaPoint™ Fujitsu Takamisawa Hall-effect sensor (FID-828).

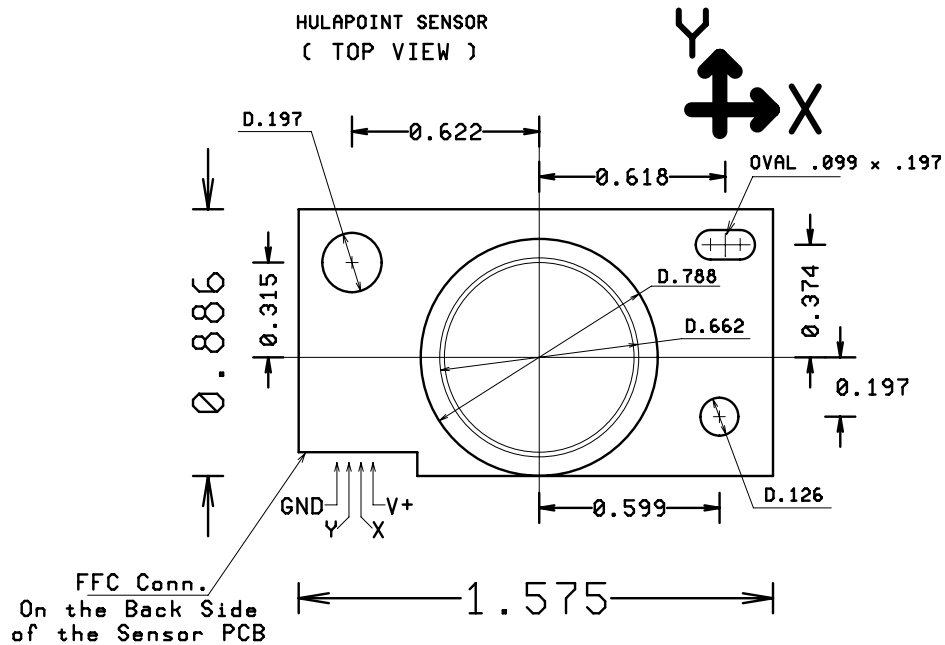
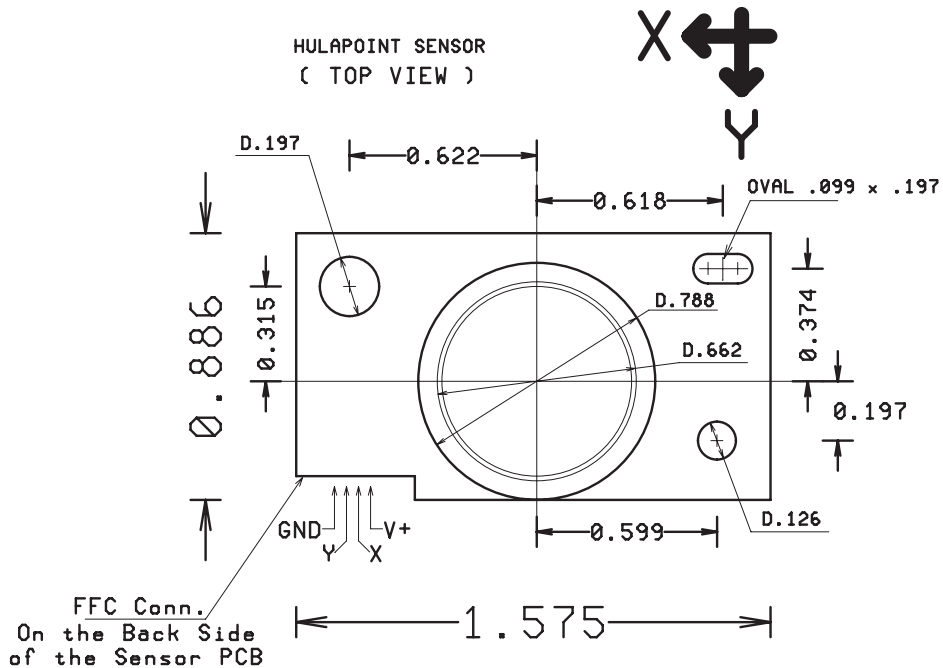
**Default sensor orientation**

**Sensor orientation with both X and Y directions inverted**

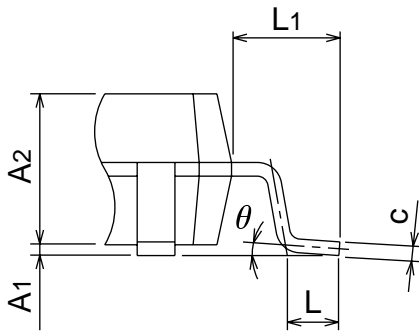
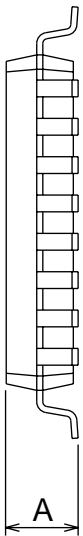
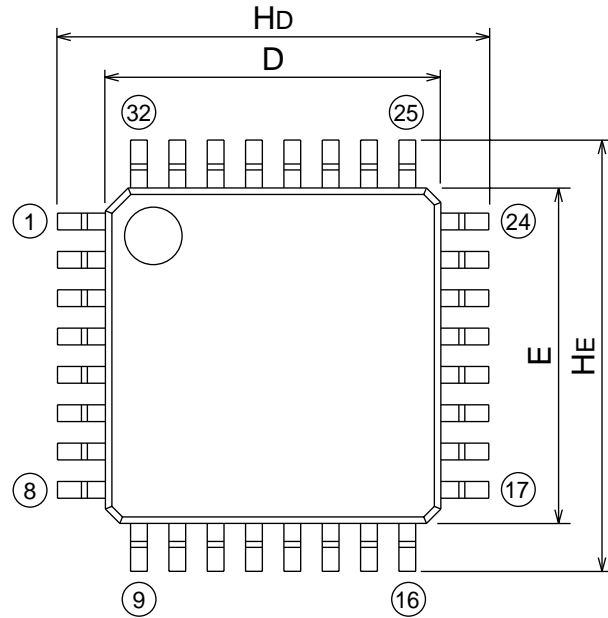
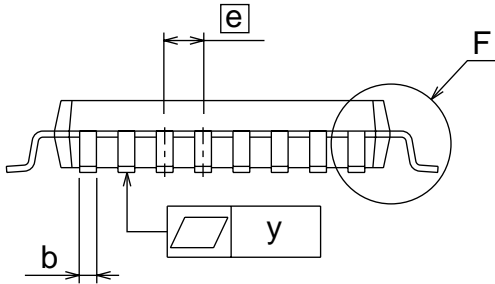

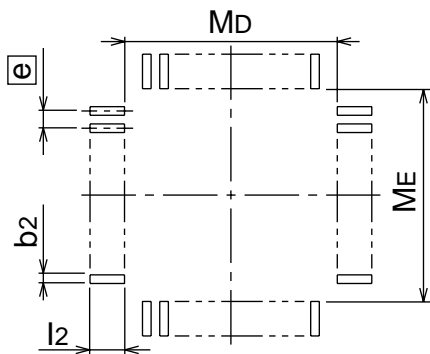

**Detail F**



**Recommended PCB Footprint**

Symbol	Dimension in Millimeters		
	Min	Nom	Max
A	–	–	1.7
A1	0	0.1	0.2
A2	–	1.4	–
b	0.3	0.35	0.45
c	0.105	0.125	0.175
D	6.9	7.0	7.1
E	6.9	7.0	7.1
e	–	0.8	–
Hd	8.8	9.0	9.2
HE	8.8	9.0	9.2
L	0.3	0.5	0.7
L1	–	1.0	–
y	–	–	0.1
$\theta$	0Y	–	10Y
b2	–	0.5	–
l2	1.0	–	–
MD	–	7.4	–
ME	–	7.4	–



**ELECTRICAL SPECIFICATIONS FOR THE SH1211 MOUSECODER®**

**Absolute maximum ratings**

Ratings	Symbol	Value	Unit
Supply voltage	V <sub>DD</sub>	-0.3 to 7.0	V
Input voltage	V <sub>IN</sub>	V <sub>SS</sub> -0.3 to V <sub>DD</sub> +0.3	V
Current drain per pin (not including V <sub>SS</sub> or V <sub>DD</sub> )	I	20	mA
Operating temperature SH1211	T <sub>A</sub>	T <sub>LOW</sub> to T <sub>HIGH</sub> -20 to +85	°C
Storage temperature range	T <sub>STG</sub>	-40 to +125	°C
<b>ESD rating</b> (human body model)	V <sub>ESD</sub>	2.0	kV

**DC electrical characteristics, temperature range = T<sub>LOW</sub> to T<sub>HIGH</sub> unless otherwise noted)**

Characteristic	Symbol	Min	Typ	Max	Unit
Supply voltage		3.3	5.0	5.5	V
Output voltage (10 μA load)	V <sub>OH</sub> V <sub>OL</sub>	V <sub>DD</sub> -0.1		0.1	V
Input high voltage	V <sub>IH</sub>	0.8V <sub>DD</sub>		V <sub>DD</sub>	V
Input low voltage	V <sub>IL</sub>	V <sub>SS</sub>		0.2V <sub>DD</sub>	V
Input current	I <sub>IN</sub>			+/- 1	μA
Supply current (V <sub>DD</sub> =5.0 VDC +/- 10%, V <sub>SS</sub> =0)	I <sub>DD</sub>		3.0	TBD	mA

**Control timing (V<sub>DD</sub> = 5.0 VDC +/- 10%, V<sub>SS</sub> = 0 VDC, temperature range = T<sub>LOW</sub> to T<sub>HIGH</sub> unless otherwise noted)**

Characteristic	Symbol	Min	Typ	Max	Unit
Frequency of operation					
■ Crystal option	f <sub>osc</sub>		4.0		MHz
■ External clock option	f <sub>osc</sub>		4.0		MHz



This Page Left Intentionally Blank



**For sales information  
and product literature,  
contact:**

Semtech Corporation  
Human Interface Device (HID)  
and System Management Division  
200 Flynn Road  
Camarillo, CA 93012-8790  
**sales@semtech.com**  
**<http://www.semtech.com/>**  
(805)498-2111 Telephone  
(805)498-3804 Fax

Copyright ©1995-2003 Semtech Corporation. All rights reserved. Semtech, the Semtech logo, MouseCoder, and HulaPoint are marks of Semtech Corporation. Force Sensing Resistor and FSR are marks of Interlink Electronics, Inc. MicroPoint is a mark of Varatouch Technology, Inc. All other marks belong to their respective owners.

LIMITED LICENSE GRANTED: NO WARRANTIES MADE  
This specification is provided "as is" with no warranties whatsoever including any warranty of merchantability, fitness for any particular purpose, or any warranty otherwise arising out of any proposal, specification or sample. Any suggestions or comments by Semtech concerning use of this product are opinion only, and Semtech makes no warranty as to results to be obtained in any specific application. A license is hereby granted to reproduce and distribute this specification for internal use only. No other license, expressed or implied to any other intellectual property rights is granted or intended hereby. Authors of this specification disclaim any liability, including liability for infringement of proprietary rights, relating to the implementation of information in this specification. Authors of this specification also do not warrant or represent that such implementation(s) will not infringe such rights.