

INTRODUCTION

The S5L1462B01 is used for CD and DVD playback. It receives optical signal from the optical pick-up to produce the data-generating RF signal, the servo error signal for stable servo control, and the monitor signal. This RF IC can be used in the CD 1x, 2x, or the DVD 1x CLV (Constant Linear Velocity) mode. The DVD mode is compatible with the Single/Dual Layer disc. The CD mode is compatible with the CD-ROM, CD-R and CD-RW disc.

FEATURES

- Can be used with CD 1x, 2x, and DVD 1x playback mode.
- Able to input and handle all optical signal of the CD-R's P/U.
- Built-in pre-amp with adjustable gain, compatible with various P/U.
- Built-in AGC (Automatic Gain Control) circuit operated by light detection feedback.
- Built-in RF AMP & Equalizer compatible with CD 1x, 2x, and DVD 1x.
- Built-in Astigmatism Method FE (Focus Error) AMP for CD and DVD use.
- Built-in 3-BEAM TE (Tracking Error) AMP for CD.
- Built-in 1-BEAM DPD (Differential Phase Detector) TE AMP for DVD.
- Built-in RF mirror detection circuit for CD and DVD.
- Built-in RF defect detection circuit for CD and DVD.
- Built-in FOK (Focus O.K.) signal detection circuit for CD and DVD.
- Built-in RF envelope signal generating circuit for CD and DVD.
- Built-in interrupt defect detection circuit.
- Built-in ALPC (Automatic Laser Power Control) circuit for CD and DVD.
- Built-in standard voltage generating circuit for analog circuit use (2.5V, 1.65V).
- Built-in defective waveform detection circuit.
- Power operating range: 4.5 – 5.5 V, 3.0 – 3.6 V.
- 80 PIN, QFP.

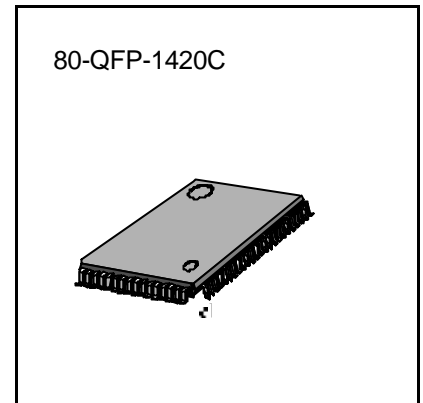

ORDERING INFORMATION

Device	Package	Temperature Range
S5L1462B01-Q0R0	80-QFP-1420C	-25 to +70°C

BLOCK DIAGRAM

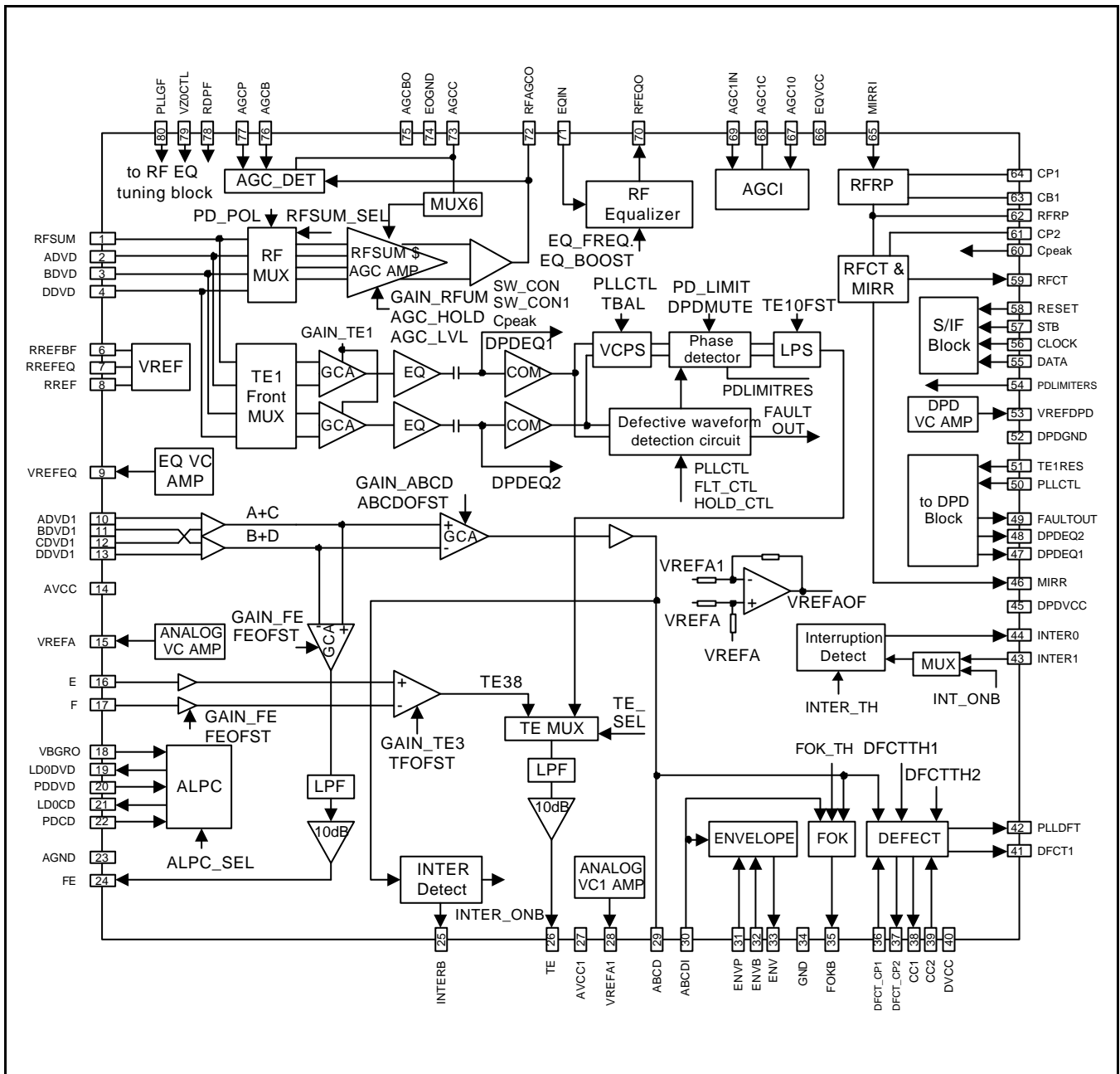

PIN DESCRIPTION

No.	Name	I/O	Description	Related Blocks	Related Parts
1	RFSUM	I	RF optical's main beam RFSUM AC Coupling input pin	PRE AMP	P/U
2	ADVD	I	RF optical's main beam A AC Coupling input pin	PRE AMP	P/U
3	BDVD	I	RF optical's main beam B AC Coupling input pin	PRE AMP	P/U
4	CDVD	I	RF optical's main beam C AC Coupling input pin	PRE AMP	P/U
5	DDVD	I	RF optical's main beam D AC Coupling input pin	PRE AMP	P/U
6	RREFBF	-	RF AMP I/O Buffer Bias resistance connection pin	RF AMP	-
7	RREFEQ	-	RF EQ Bias resistance connection pin	RF EQ	-
8	RREF	-	ANALOG Block Bias resistance connection pin	ANALOG	-
9	VREFEQ	O	RF EQ Center voltage CAP connection pin	EQ VC AMP	-
10	ADVD1	I	SERVO optical's main beam A input pin	SERVO AMP	P/U
11	BDVD1	I	SERVO optical's main beam B input pin	SERVO AMP	P/U
12	CDVD1	I	SERVO optical's main beam C input pin	SERVO AMP	P/U
13	DDVD1	I	SERVO optical's main beam D input pin	SERVO AMP	P/U
14	AVCC	P	ANALOG Part power voltage (5 V) input pin	ANALOG	-
15	VREFA	-/O	ANALOG Part Center voltage CAP connection pin. Uses another block.	ANA VC AMP	SERVO
16	E	I	SERVO CD optical's sub beam E input pin	TE 3B	P/U
17	F	I	SERVO CD optical's sub beam F input pin	TE 3B	P/U
18	VBGRO	I/O	ALPC Bandgap voltage input and bandgap output pin	ALPC	-
19	LDODVD	O	DVD optical's Laser Diode operating voltage output pin	ALPC	P/U
20	PDDVD	I	DVD optical's Laser Monitor Diode voltage input pin	ALPC	P/U
21	LDOCD	O	CD optical Laser Diode operating voltage output pin	ALPC	P/U
22	PDCD	I	CD optical Laser Monitor Diode voltage input pin	ALPC	P/U
23	AGND	P	ANALOG Part power GND pin	ANALOG	-
24	FE	O	FE AMP output pin	FE AMP	DSSP
25	INTERB	O	Interruption button detection time constant cap. connection	INTERRUPTION	SERVO
26	TE	O	TE AMP output pin	TE AMP	DSSP
27	AVCC1	P	ANALOG Part power voltage (3.3 V) input pin	ANALOG	-
28	VREFA1	-/O	ANALOG Part Center voltage1 (1.65 V) CAP connection pin	ANA VC1 AMP	-
29	ABCD	O	ABCD AMP output pin	ABCD AMP	-
30	ABCDI	I	SERVO MONITOR ABCD AC Coupling input pin	SERVO MONIT	-

PIN DESCRIPTION (Continued)

No.	Name	I/O	Description	Related Blocks	Related Parts
31	ENVP	-	RF ENVELOPE detecting Peak Hold time constant selection RC connection pin	RF ENV	-
32	ENVB	-	RF ENVELOPE detecting Bottom Hold time constant selection RC connection pin	RF ENV	-
33	ENV	O	RF ENVELOPE Detect output pin	RF ENV	DSSP
34	DGND	P	DIGITAL Circuit power GND input pin	DIGITAL	-
35	FOKB	O	FOCUS OK Comparator output pin (L: FOCUS OK)	FOKB	DSSP
36	DFCT_CP1	-	SERVO DEFECT maximum time selection Peak Hold time constant connection pin	DFCT	-
37	DFCT_CP2	-	PLL DEFECT minimum time selection Peak Hold time constant connection pin	DFCT	-
38	CC1	O	DEFECT peak detector circuit output pin	DFCT	-
39	CC2	I	DEFECT AC Coupling input pin	DFCT	-
40	DVCC	P	DIGITAL circuit power voltage (5 V) input pin	DIGITAL	-
41	DFCT1	O	SERVO DEFECT output pin	DEFECT	DSSP
42	PLLDFT	O	PLL DEFECT output pin	DEFECT	PLL
43	INTERO	O	INTERRUPT Defect Detection output pin	INTERRUPT	-
44	INTERI	I	INTERRUPT Defect Detection input pin	INTERRUPT	-
45	DPDVCC	P	DPD TE power voltage (5V) input pin	DPD	-
46	MIRR	O	MIRROR output pin	MIRR	DSSP
47	DPDEQ1	O	DPD EQ (A+C) output pin	DPD	-
48	DPDEQ2	O	DPD EQ (B+D) output pin	DPD	-
49	FAULTOUT	O	DPD abnormal waveform output pin (MONITOR)	DPD	-
50	PLLCTL	I	DPD TE PLL variable input pin	DPD	SERVO
51	TE1RES	I	DPD TE PLL variable bias resistance	DPD	-
52	DPDGND	P	DPD TE power GND input pin	DPD	-
53	VREFDPD	O	DPD TE CENTER voltage CAP connection pin	DPD VC AMP	-
54	PDLIMITRES	-	PDLIMITK BIAS resistance connection pin	DPD	-
55	DATA	I	DATA input pin	Serial Interface	MICOM
56	CLOCK	I	CLOCK input pin	Serial Interface	MICOM
57	STB	I	DATA ENABLE input pin	Serial Interface	MICOM
58	RESET	I	Serial Register Reset pin	Serial Interface	MICOM
59	RFCT	O	MIRROR RF RIPPLE CENTER voltage output pin	MIRROR	DSSP
60	Cpeak	-	AGC/AGC1 peaking protection SW control voltage input pin	AGC/AGC1	-

PIN DESCRIPTION (Continued)

No.	Name	I/O	Description	Related Blocks	Related Parts
61	CP2	-	RFCT generating PEAK HOLD time constant RC connection pin	MIRROR	-
62	RFRP	O	MIRROR RF RIPPLE AMP output pin	MIRROR	DSSP
63	CB1	-	RFRP generating BOTTOM HOLD time constant RC connection pin	MIRROR	-
64	CP1	-	RFRP generating PEAK HOLD time constant RC connection pin	MIRROR	-
65	MIRRI	I	MIRR signal generating input pin	MIRROR	-
66	EQVCC	P	RF EQ power voltage input pin	RF EQ	-
67	AGC1O	O	RF AGC1 AMP output pin	RF AGC1	-
68	AGC1C	-	AGC1 time constant CAP connection pin	RF AGC1	-
69	AGC1IN	I	RF AGC1 AMP input pin	RF AGC1	-
70	RFEQ0	O	RF EQ output pin	RF EQ	PLL
71	EQIN	I	RF EQ RFAGCO input pin	RFEQ RFENV	DSSP
72	RFAGCO	O	RF AGC AMP output pin	RF AGC	-
73	AGCC	-	AGC time constant CAP connection pin	RF AGC	-
74	EQGND	P	RF EQ power GND input pin	RF EQ	-
75	AGCBO	-	RF EQ BIAS resistance connection pin	RF EQ	-
76	AGCB	-	RF AGC RF BOTTOM HOLD time constant RC connection pin	RF AGC	-
77	AGCP	-	RF AGC RF PEAK HOLD time constant RC connection pin	RF AGC	-
78	RDPF	-	RF EQ FREQUENCY selection BIAS resistance connection pin	RF EQ	-
79	VZOCTL	I	RF EQ zero control voltage	RF EQ	DSSP
80	PLLGF	I	Wide range PLL RF EQ BOOST, PEAK FREQUENCY GAIN control pin (internally designed PLLG, PLLF resistance)	RF EQ	DSSP

ABSOLUTE MAXIMUM RATINGS ($T_a = 25^\circ\text{C}$)

Item	Symbol	Standard Value	Unit	Notes
Power Voltage	V_s	6	V	
Operating Temperature	Temp	-25 to +70	$^\circ\text{C}$	
Power Expenditure	P_D	1100	mW	
Storage Temperature	Tstg	-40 to +125	$^\circ\text{C}$	

Item	Symbol	Standard Value			Unit	Notes
		MIN	TYP	MAX		
Power Voltage	V_o	4.75	5	5.25	V	
Operating Current	I_c	-	120	160	mA	

ELECTRICAL CHARACTERISTICS

($V_{CC} = 5V$, $V_{CC1} = 3.3V$, $GND = 0V$, $V_c = 2.5V$, $V_{c1} = 1.65V$ $T_a = 25^\circ C$, V_C is center of standard output voltage.)

No	Item	Symbol	Input	Measuring point	Output			Unit			
					Min.	Typ.	Max.				
CIRCUIT CURRENT											
1	Supply current	IccL	vdd=4.5V,TE1 BLOCK operation		80	100	120	mA			
2	Supply current	IccT	vdd=5V,TE1 BLOCK operation		100	120	140	mA			
3	Supply current	IccH	vdd=5.5V,TE1 BLOCK operation		120	140	160	mA			
RF SUM & AGC AMP											
4	RF Sum Amp Voltage Gain	Vrfsum1	RFSUM=1MHz, 1.5Vpp, RFSUM_SEL=0 GAIN_RFSUM=0dB, DVD Mode	RFAGCO (AGC_LVL=0 1H,)	0.8	1	1.2	Vpp			
5		Vrfsum2	RFSUM=1MHz, 1Vpp,RFSUM_SEL=0 GAIN_RFSUM=0dB, DVD Mode								
6		Vrfsum3	RFSUM=1MHz, 0.1Vpp, RFSUM_SEL=0 GAIN_RFSUM=20dB, CD Mode								
7		Vrfsum4	(A-D)DVD=1MHz, 0.25Vpp, RFSUM_SEL=1 GAIN_RFSUM=0dB, DVD Mode								
8	RF Sum Amp Unit Gain Bandwidth	Frfsun1	RFSUM=Freq. Sweep, 1.0Vpp, RFSUM_SEL=0, GAIN_RFSUM=0dB,DVD Mode		10	-	-	MHz			
9		Frfsun2	RFSUM=Freq. Sweep, 0.1Vpp, RFSUM_SEL=0, GAIN_RFSUM=20dB,CD Mode		5	-	-				
10	AGC Voltage Gain	Gagc1	RFSUM=1MHz, 2Vpp, RFSUM_SEL=0 GAIN_RFSUM=0dB, DVD Mode		0.8	1.0	1.2	Vpp			
11		Gagc2	RFSUM=1MHz, 0.5Vpp, RFSUM_SEL=0 GAIN_RFSUM=0dB, DVD Mode								
12	AGC AMP Out. LEVEL Adjust RANGE	Vagc1	RFSUM=1MHz, 1Vpp, RFSUM_SEL=0 GAIN_RFSUM=0dB, AGC_LVL=00H, DVD Mode	RFAGCO (AGCHOLD=L)	0.3	0.5	0.7	Vpp			
13		Vagc2	RFSUM=1MHz, 1Vpp, RFSUM_SEL=0 GAIN_RFSUM=0dB, AGC_LVL=10H, DVD Mode						0.55	0.75	0.95
14		Vagc3	RFSUM=1MHz, 1Vpp, RFSUM_SEL=0 GAIN_RFSUM=0dB, AGC_LVL=11H, DVD Mode						1.00	1.25	1.50

ELECTRICAL CHARACTERISTICS (Continued)

No	Item	Symbol	Input	Measuring point	Output			Unit
					Min.	Typ.	Max.	
AGC1								
15	AGC1 Out. Level	Vagc1	AGC1IN:sin 0.5Vpp 5MHz dc 2.5V AGC1_HOLD: 1, AGC1_LVL:01, AGC1_ON:0	AGC10	0.8	1	1.2	Vpp
16	AGC1 Out. Level 1	Vagc11	AGC1IN:sin 0.5Vpp 5MHz dc 2.5V AGC1_HOLD:1, AGC1_LVL:00, AGC1_ON:0	AGC10	0.6	0.75	0.9	Vpp
17	AGC1 Out. Level 2	Vagc12	AGC1IN:sin 0.5Vpp 5MHz dc 2.5V AGC1_HOLD: 1, AGC1_LVL:11, AGC1_ON:0	AGC10	1.15	1.45	1.75	Vpp
18	Band Width (-3dB)	Fagc12	AGC1IN:sin 0.5Vpp 5MHz dc 2.5V AGC1_HOLD: 1, AGC1_LVL:01, AGC1_ON:0	AGC10	6	-	-	MHz
19	AGC1 Normal Gain	Aagc1	AGC1IN:sin 0.5Vpp 5MHz dc 2.5V AGC1_HOLD: 1, AGC1_LVL:11, AGC1_ON:0	AGC10		20		dB
20	AGC1 Out. DC	Vdcagc1	AGC1IN: dc 2.5V AGC1_HOLD: 1, AGC1_LVL:11, AGC1_ON:0	AGC10		2.5		V
ABCD SUM AMP								
21	ABCD SUM AMP voltage gain	Vsum1	(A-D)DVD1=0.5MHz, 250mVpp+Vc, DVD Mode GAIN_ABCD:6dB	ABCD	1.8	2.0	2.2	Vpp
22		Vsum2	(A-D)DVD1=200kHz, 20mVpp+Vc, CD Mode GAIN_ABCD:30dB					
23	RF SUM AMP -3dB Gain Bandwidth	Fsum1	(A-D)DVD1=Freq. Sweep,250mVpp+Vc, DVD Mode, GAIN_ABCD:6dB	ABCD	500	-	-	kHz
24		Fsum2	(A-D)DVD1= Freq. Sweep,125mVpp+Vc, CD Mode, GAIN_ABCD:12dB					

Electrical Characteristics (Continued)

No	Item	Symbol	Input	Measuring point	Output			Unit
					Min.	Typ.	Max.	
RF EQUALIZER								
25	EQ Standard Output	Vrfeqdvd	EQIN=100kHz, 1Vpp,	RFEQO	1.5	2.0	2.3	Vpp
26	EQ Peak Frequency	Fpeakdvd	EQIN= Freq. Sweep, 250mVpp	EQF=80H EQG=83H		6.4		MHz
27	EQ Out DC	Veq_dc	EQIN=DC 2.5V	RFEQO EQF=80H EQG=83H	2	2.5	3	V
28	EQ Peak Frequency DVD	F1dvd	EQIN =0.4MHz, 250mVpp	RFEQO EQ_BOOST =0dB	-2	0	2	dB
29		F2dvd	EQIN =3.54MHz, 250mVpp	EQG_CEN =9dB	4.0	6.0	8.0	
30		F3dvd	EQIN =6.4MHz, 250mVpp	EQ_FREQ =0%	7.0	9.0	11.0	
31		F4dvd	EQIN=12.8MHz,250mVpp		-30	-10	0	
32	Boost Gain Range DVD	Gbg1dvd	EQIN=Freq. Sweep 250mVpp EQG=80H	RFEQO EQF=80H	2	4	6	dB
33		Gbg2dvd	EQIN=Freq. Sweep 250mVpp EQG=81H		4	6	8	
34		Gbg3dvd	EQIN=Freq. Sweep 250mVpp EQG=82H		6	8	10	
35		Gbg4dvd	EQIN=Freq. Sweep 250mVpp EQG=83H		9	11	13	
36	EQ peak frequency CD	F1cd	RFSUM=0.1MHz, 250mVpp	RFEQO EQ_BOOST =0dB	-1	0	+1	dB
37		F1cd	RFSUM=0.5MHz, 250mVpp	EQG_CEN =9dB	1.5	3.5	5.5	
38		F1cd	RFSUM=0.72MHz, 250mVpp	EQ_FREQ =0%	7.0	9.0	11.0	
39		F1cd	RFSUM=1.4MHz, 250mVpp		-30	-10	0	
40	Boost Gain Range cd	Gbg1cd	EQIN=Freq Sweep 250mVpp EQG=80H	RFEQO EQF=80H	3	4	5	dB
41		Gbg2cd	EQIN=Freq Sweep 250mVpp EQG=81H		4	6	8	
42		Gbg3cd	EQIN=Freq Sweep 250mVpp EQG=82H		6	8	10	
43		Gbg4cd	EQIN=Freq Sweep 250mVpp EQG=83H		9	11	13	

ELECTRICAL CHARACTERISTICS (Continued)

No	Item	Symbol	Input	Measuring point	Output			Unit
					Min.	Typ.	Max.	
FOCUS ERROR AMP								
44	Voltage Gain	Vfedvd1	(A,C)DVD1=1kHz Sine, 630mVpp+Vc (B,D)DVD1=1kHz Sine(I) 630mVpp+Vc GAIN_FE=-2dB, DVD Mode	FE	1.8	2.0	2.2	Vpp
45		Vfedvd2	(A,C)DVD1=1kHz Sine 63mVpp+Vc (B,D)DVD1=1kHz Sine(I) 63mVpp+Vc GAIN_FE=18dB, DVD Mode					
46		Vfecd1	(A,C)DVD1=1kHz Sine 200mVpp+Vc (B,D)DVD1=1kHz Sine(I) 200mVpp+Vc GAIN_FE=8dB, CD Mode					
47		Vfecd2	(A,C)DVD1=1kHz Sine 40mVpp+Vc (B,D)DVD1=1kHz Sine(I) 40mVpp+Vc GAIN_FE=22dB, CD Mode					
48	Output Voltage H	Vfehvd	(B,D)DVD1=Vc+0.7V, (A,C)DVD1=Vc, GAIN_FE=-2dB, DVD	FE	2.8	2.9		V
49	Output Voltage L	Vfeldvd	(B,D)DVD1=Vc-0.7V, (A,C)DVD1=Vc, GAIN_FE=-2dB, DVD					
50	Output Voltage H	Vfehcd	(B,D)DVD1=Vc+0.7V, (A,C)DVD1=Vc, GAIN_FE=0dB, CD	FE	2.8	2.9		V
51	Output Voltage L	Vfelcd	(B,D)DVD1=Vc-0.7V, (A,C)DVD1=Vc, GAIN_FE=0dB, CD					
52	Bandwidth (-3dB Freq.)	Ffedvd	(A,C)DVD1=Sine 63mVpp+Vc (B,D)DVD1=Sine(I) 63mVpp+Vc GAIN_FE=18dB, Freq. Sweep, DVD Mode	FE	25K	35K	45K	Hz
53		Ffecd	(A,C)DVD1=Sine 63mVpp+Vc (B,D)DVD1=Sine(I) 63mVpp+Vc GAIN_FE=18dB, Freq. Sweep, CD Mode					
54	Offset Voltage	Vosfe	(A-D)DVD1=Vc, GAIN_FE=18dB, FEOFST=80H	FE	-300	0	300	mV

ELECTRICAL CHARACTERISTICS (Continued)

No	Item	Symbol	Input	Measuring point	Output			Unit
					Min.	Typ.	Max.	
TRACKING ERROR AMP (1-BEAM)								
55	DPD EQ Standard Gain	Vdpdeq1	(A-D)DVD= 500mVpp 200kHz Sine+Vc, GAIN_TE1 = 0dB	DPDEQ1 DPDEQ2	1.8	2.0	2.2	Vpp
56		Vdpdeq2	(A-D)DVD= 45mVpp 200kHz Sine+Vc, GAIN_TE1 = 27dB					
57	DPD EQ Gain Characteristics Variable range	Gdpdeqr	(A-D)DVD: 251mVpp Freq. Sweep Sine+Vc, GAIN_TE1 = 12dB	(INT_ONB=1 FLT_CNT=1)	4	8	11	dB
58	Output Voltage Correspond to Phase Difference	Vph0	(A-D)DVD: 251mVpp 5MHz Sine+Vc (A,C)DVD, (B,D) DVD's phase difference 0° GAIN_TE1 = 12dB	TE (INT_ONB=1 FLT_CNT=1)	1.2	1.65	2.1	V
59		Vph1	(A-D)DVD: 251mVpp 5MHz Sine+Vc When (A,C)DVD's phase difference is 45° ahead of (B,D)DVD, GAIN_TE1 = 12dB		0.05	0.65	1.05	V
60		Vph2	(A-D)DVD: 251mVpp 5MHz Sine+Vc When (A,C)DVD's phase difference is 45° behind (B,D)DVD GAIN_TE1 = 12dB		2.25	2.65	3.25	V
61	Tracking Balance Adjustment Range	Vbal1	(A,C)DVD=251mVpp 2.616MHz Sine + Vc (B,D)DVD=251mVpp 2.616MHz Sine + Vc TBAL=00H, GAIN_TE1=12dB	TE (INT_ONB=1 FLT_CNT=1)		0.33		V
62		Vbal2	(A,C) DVD=251mVpp 2.616MHz Sine + vc (B,D) DVD=251mVpp 2.616MHz Sine + vc TBAL=FFH, Gain TE1=12dB			2.97		
63	Phase Comparator Limit	Vphlim1	(A,C)DVD=2MHz, 300mVpp, duty 50% Pulse (B,D)DVD signal with a phase 90° late PD_LIMIT=90ns	TE (INT_ONB=1 FLT_CNT=1)	2.55		3.25	V
64		Vphlim2	(B,D)DVD=2MHz, 300mVpp, duty 50% Pulse (A,C)DVD signal with a phase 90° late PD_LIMIT=90ns		0.05		0.75	
65	Abnormal Waveform Detection Circuit	Tflt	(A,C)DVD=251mVpp,100kHz (B,D)DVD=251mVpp,2.616MHz Time measurement from Falling Edge with only (B,D)DVD, to when FAULTO becomes H	(B,D)DVD FAULTO	450		900	ns
66	Offset Voltage	Voste1	(A,,B)DVD. (B,D) DVD =VC Gain_TE1=27dB TEOFST=80H	TE (INT_ONB=1 FLT_CNT=1)	-300	0	300	mV

ELECTRICAL CHARACTERISTICS (Continued)

No	Item	Symbol	Input	Measuring point	Output			Unit
					Min.	Typ.	Max.	
TRACKING ERROR AMP (3-BEARN)								
67	TE3 Voltage Gain	Vte31	E=1kHz Sine 316mVpp+Vc F=1kHz Sine(I) 316mVpp+Vc TBAL=80, GAIN_TE3=10dB, TEOFST=80H	TE	1.8	2.0	2.2	Vpp
68		Vte32	E=1kHz Sine 30mVpp+Vc, F=1kHz Sine(I) 30mVpp+Vc, TBAL=80, GAIN_TE3=30dB, TEOFST=80H	TE				
69	Out. Voltage H	Vte3h	E=Vc-0.7V,F= Vc,GAIN_FE=10dB	TE	2.8	2.9		V
70	Out. Voltage L	Vte3l	E=Vc+0.7V,F=Vc,GAIN_FE=10dB	TE		0.4	0.5	
71	Bandwidth (-3dB Freq.)	Fte3	E=Sine 316mVpp+Vc, Freq. Sweep F=Sine(I) 316mVpp+Vc, Freq. Sweep TBAL=80H, GAIN_TE3=10dB, TEOFST=80H	TE	45K	60K	75K	Hz
72	Tracking Balance Range	Gte31	E=1kHz Sine 316mVpp+Vc F=1kHz Sine(I) 316mVpp+Vc TBAL=00H, GAIN_TE3=18dB, TEOFST=80H	TE	3	-	-	dB
73		Gte32	E=1kHz Sine 316mVpp+Vc F=1kHz Sine(I) 316mVpp+Vc TBAL=FFH, GAIN_TE3=18dB, TEOFST=80H		-	-	-3	dB
74	Offset Voltage	Voste3	E,F=Vc,TBAL=80, GAIN_TE3=26dB, TE3OFST=80H	TE	-300	0	300	mV
75	Tracking Offset Range	Voste31	E,F=Vc, TBAL=80, Gain=TE3=26dB TEOFST=00H	TE	0		0.5	V
76		Voste32	E,F=Vc, TBAL=80, Gain=TE3=26dB TEOFST=FFH	TE	0.3		3.3	V

ELECTRICAL CHARACTERISTICS (Continued)

No	Item	Symbol	Input	Measuring point	Output			Unit
					Min.	Typ.	Max.	
MIRROR CIRCUIT								
77	Output Voltage H	Vmirh	MIRRI=1Vpp 1kHz sine 30% AM fc = 5MHz	MIRR	4.5	-	-	V
78	Output Voltage L	VmirL	dc=2.5V RFRPOFST=30 RFRP_FRQ=30kHz Gain_RFRP=14dB		-	-	0.4	
79	Mirr Hold Frequency	Fhold1 (DVD)	Measure the Freq. of No 65	MIRR	990	1000	1010	Hz
80		Fhold2 (CD)	Mirri=1Vpp 1kHz sine 30% AM fc=5MHz dc=2.5V, RFRPOFST=30 RFRP_FRQ=320kHz Gain_RFRP=14dB		99	100	101	kHz
81	RFRP Output Level 1	Vfrfp1 (DVD)	Mirri=1Vpp 1kHz sine 30% AM fc=5MHz dc=2.5V RFRP_OFST=30 RFRP_FRQ=30kHz Gain_RFRP=12dB	RFRP	1.0	1.15	1.30	Vpp
82		Vfrfp2 (CD)	Mirri=1Vpp 1kHz sine 30% AM fc=500kHz dc=2.5V RFRP_OFST=30 RFRP_FRQ=30kHz Gain_RFRP=12dB					
83	RFRP Output Level 2	Vfrfp3 (DVD)	Mirri=1Vpp 20kHz sine 30% AM fc=5MHz dc=2.5V RFRP_OFST=30 RFRP_FRQ=30kHz Gain_RFRP=12dB	RFRP	700	850	1000	mVpp
84		Vfrfp4 (CD)	Mirri=1Vpp 300kHz sine 30% AM fc=5MHz dc=2.5V RFRP_OFST=30 RFRP_FRQ=320kHz Gain_RFRP=12dB					
85	RFRP Output Variable Range	Avorfrp1	Mirri=1Vpp 1kHz sine 30% AM fc=5MHz dc=2.5V RFRP_OFST=30 RFRP_FRQ=30kHz Gain_RFRP=12dB	RFRP	4.5	6	7.5	dB
86		Avorfrp2	Mirri=1Vpp 1kHz sine 30% AM fc=500kHz dc=2.5V RFRP_OFST=30 RFRP_FRQ=320kHz Gain_RFRP=14dB					

ELECTRICAL CHARACTERISTICS (Continued)

No	Item	Symbol	Input	Measuring point	Output			Unit
					Min.	Typ.	Max.	
MIRROR CIRCUIT								
87	RFRP Bandwidth (-3dB)	Ffrp1	Mirri=1Vpp 60kHz sine 30% AM fc=5MHz dc=2.5V RFRP_OFST=30 RFRP_FRQ=30kHz Gain_RFRP=12dB	RFRP		60		kHz
88		Ffrp2	Mirri=1Vpp 120kHz sine 30% AM fc=5MHz dc=2.5V RFRP_OFST=30 RFRP_FRQ=30kHz Gain_RFRP=12dB			120		

ELECTRICAL CHARACTERISTICS (Continued)

No	Item	Symbol	Input	Measuring point	Output			Unit
					Min.	Typ.	Max.	
DEFECT DETECT CIRCUIT								
89	Output Voltage H	Vdefh	(A-D)DVD1=1kHz 250mVpp+Vc Gain_ABCD=0dB ABCDOFST=80	DFCT DFTP_TH =300mV DFT_TH =100mV	4.5			V
90	Output Voltage L	Vdefl	(A-D)DVD1=1kHz 250mVpp+Vc Gain_ABCD=0dB ABCDOFST=80				0.4	
91	Min Operation Frequency	Fdef1	(A-D)DVD1=1kHz 250mVpp+Vc Gain_ABCD=0dB ABCDOFST=80				1.0	kHz
92	Max Operation Frequency	Fdef2	(A-D)DVD1=5kHz 250mVpp+Vc Gain_ABCD=0dB ABCDOFST=80		5.0			
93	Minimum Input Operation Voltage	Vdefin1	(A-D)DVD1=5kHz 150mVpp+Vc Gain_ABCD=0dB ABCDOFST=80				0.5	Vpp
94	Maximum Input Operation Voltage	Vdefin2	(A-D)DVD1=5kHz 600mVpp+Vc Gain_ABCD=0dB ABCDOFST=80		1.8			
95	High Speed Peak Hold Time Constant Range	Tphr1	(A-D)DVD1: 250mVpp+Vc Square 5kHz Gain_ABCD=0dB DFCT_CNST=5.6us/V			5.7		us/V
96		Tphr2	(A-D)DVD1: 250mVpp+Vc Square 5kHz Gain_ABCD=0dB DFCT_CNST=60us/V			60		
FOK DETECT CIRCUIT								
97	Output Voltage H	Vfokh	(A-D)DVD1=250mVpp 1kHz Sine wave, GAIN_ABCD=0dB FOK_TH=80	FOKB	4.5			V
98	Output Voltage L	Vfokl					0.4	
99	Maximum Operation Frequency	Ffok	(A-D)DVD1=250mVpp 45kHz GAIN_ABCD=0dB, FOK_TH=80	FOKB	45K			Hz
RF ENVELOPE AMP								
100	Output Voltage	Venv	ABCDI : 2Vpp,Sine 1MHz	ENV	1.66	1.86	2.06	V
ALPC CIRCUIT								
101	Output Voltage H	Valpch1	PDdvd: +600V LDONB=1	(LDO) dvd	4.5			V
102	Output Voltage L	Valpcl1	PDdvd: +0V LDONB=1	(LDO) dvd			0.5	
103	Output Voltage H	Valpch2	PDcd: +600mV LDONB=1	(LDO) cd	4.5			V
104	Output Voltage L	Valpcl3	PDcd: +0mV LDONB=1	(LDO) cd			0.5	
105	Input PD Voltage	Vinpd	PDdvd: DC Sweep LDONB=1 PD Value When LDdvd: 3.5V	LDO dvd	158	178	198	mV

ELECTRICAL CHARACTERISTICS (Continued)

No	Item	Symbol	Input	Measuring point	Output			Unit
					Min.	Typ.	Max.	
INTERRUPT DETECT CIRCUIT								
106	Output Voltage1 H	Vinth1	INTERI=1Vpp 1kHz INTER_TH=80 Gain_INT=3.5dB INT_SEL=1,	INTERO	4.5			V
107	Output Voltage1 L	Vintl1	INT_ONB=0					
108	Output Voltage2 H	Vinth2	(A-D)DVD1=1kHz, 250mVpp+Vc, DVD mode Gain_ABCD:6dB INTER_TH=80	INTERO	4.5			V
109	Output Voltage2 L	Vintl2	Gain_INT=3.5dB, INT_SEL=0, INT_ONB=0					
110	Minimum Operation Frequency 1	Fint11	INTERI=1Vpp, 1kHz INTER_TH=80 Gain_INT=3.5dB INT_SEL=1, INT_ONB=0	INTERO			1.0	kHz
111	Maximum Operation Frequency 1	Fint21	INTERI=1Vpp, 5kHz INTER_TH=80 Gain_INT=3.5dB INT_SEL=1, INT_ONB=0					
112	Minimum Operation Frequency 2	Fint12	(A-D)DVD1=1kHz, 250mVpp+Vc, DVD mode INTER_TH=80, Gain_INT=3.5dB INT_SEL=0, INT_ONB=0	INTERO			1.0	kHz
113	Maximum Operation Frequency 2	Fint22	(A-D)DVD1=5kHz, 250mVpp+Vc, DVD mode INTER_TH=80, Gain_INT=3.5dB INT_SEL=0, INT_ONB=0					
114	Minimum Input Operation Frequency	Vintin1	INTERI=0.5Vpp, 5kHz Pulse Symmrtry=90%, INTER_TH=80 Gain_INT=9.5dB, INT_SEL=1, INT_ONB=0	INTERO			0.5	Vpp
115	Maximum Input Operation Frequency	Vintin2	INTERI=1.8Vpp, 5kHz Pulse Symmrtry=90%, INTER_TH=80 Gain_INT=3.5dB, INT_SEL=1, INT_ONB=0					

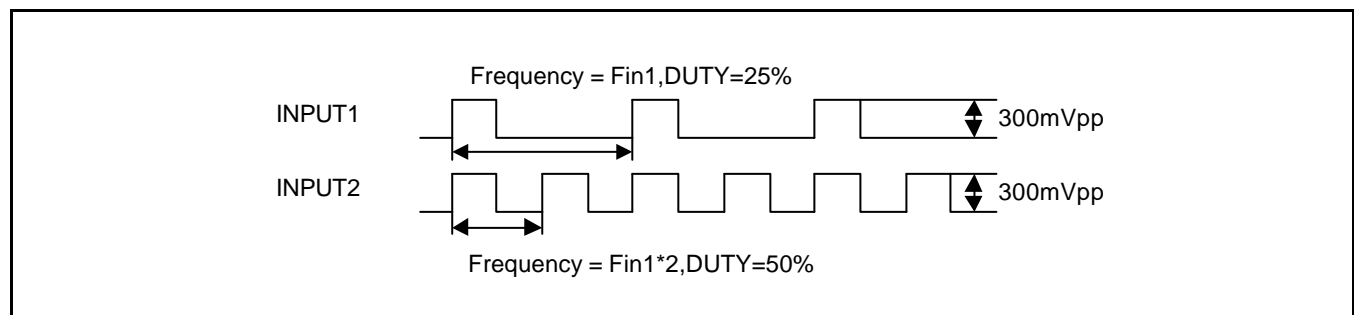

· **Address 01H : TRACKING BALANCE Adjustment**

DATA	D7	D6	D5	D4	D3	D2	D1	D0
Function	TBAL							
Initial Value	1	0	0	0	0	0	0	0

· **3 BEAM TE: F's relative change in gain compared to E, following the value change of TBAL.**

TBAL	F GAIN
00	+4dB
80	0dB
FF	-4dB

· **DPD TE: The change in the TE output voltage following the change in the TBAL value.**

TBAL	TE Output Voltage
00	-1.2V
80	0V
FF	+1.2V

· **Address 02H : GAIN_RFSUM, GAIN_TE3 GAIN selection**

DATA	D7	D6	D5	D4	D3	D2	D1	D0
Function	GAIN_RFSUM				GAIN_TE3			
Initial Value	0	0	0	1	0	0	1	0

· **GAIN_RFSUM (D4 - D7) : RF SUM input pin GAIN selection**

D7	D6	D5	D4	MODE (Value of RFAGCO compared to the input voltage)
0	0	0	0	-6dB
0	0	0	1	-4dB
0	0	1	0	-2dB
0	0	1	1	0dB
0	1	0	0	2dB
0	1	0	1	4dB
0	1	1	0	-
0	1	1	1	-
1	0	0	0	6dB
1	0	0	1	8dB
1	0	1	0	10dB
1	0	1	1	12dB
1	1	0	0	14dB
1	1	0	1	16dB
1	1	1	0	-
1	1	1	1	-

· **GAIN_TE3 (D0 - D3) : TE3 GAIN selection**

D3	D2	D1	D0	GAIN
0	0	0	0	6dB
0	0	0	1	8dB
0	0	1	0	10dB
0	0	1	1	12dB
0	1	0	0	14dB
0	1	0	1	16dB
0	1	1	0	18dB
0	1	1	1	20dB
1	0	0	0	-
1	0	0	1	-
1	0	1	0	-
1	0	1	1	-
1	1	0	0	-
1	1	0	1	-
1	1	1	0	-
1	1	1	1	-

· **Address 03H : GAIN_FE, GAIN_ABCD GAIN selection**

DATA	D7	D6	D5	D4	D3	D2	D1	D0
Function	GAIN_ABCD				GAIN_FE			
Initial Value	0	0	1	0	0	0	1	1

· **GAIN_ABCD (D4 - D7) : ABCD GAIN selection**

D7	D6	D5	D4	GAIN
0	0	0	0	0dB
0	0	0	1	2dB
0	0	1	0	4dB
0	0	1	1	6dB
0	1	0	0	8dB
0	1	0	1	10dB
0	1	1	0	12dB
0	1	1	1	14dB
1	0	0	0	16dB
1	0	0	1	18dB
1	0	1	0	20dB
1	0	1	1	22dB
1	1	0	0	24dB
1	1	0	1	26dB
1	1	1	0	28dB
1	1	1	1	30dB

· **GAIN_FE (D0 - D3) : FE GAIN selection**

D3	D2	D1	D0	GAIN
0	0	0	0	-2dB
0	0	0	1	0dB
0	0	1	0	2dB
0	0	1	1	4dB
0	1	0	0	6dB
0	1	0	1	8dB
0	1	1	0	10dB
0	1	1	1	12dB
1	0	0	0	14dB
1	0	0	1	16dB
1	0	1	0	18dB
1	0	1	1	20dB
1	1	0	0	22dB
1	1	0	1	24dB
1	1	1	0	26dB
1	1	1	1	28dB

· **Address 04H - 06H : Various offset adjustment data**

ADDRESS	Data	Initial Value
04H	TE(1,3) Offset	80H
05H	FE Offset	80H
06H	ABCD Sum Offset	80H

The output OFFSET is at its minimum at 00H, maximum at FFH, and 2.5 V at 80H.

· **Address 07H: DPD PD LIMIT GAIN_TE1 HOLD_CTL selection**

DATA	D7	D6	D5	D4	D3	D2	D1	D0
Function	DPD_MUTE	GAIN_TE1			PD_LIMIT			
Initial Value	0	0	1	0	0	0	0	0

DPD_MUTE (D7): DPD TE input pin GAIN selection

0: DPD MUTE OFF

1: DPD MUTE ON

GAIN_TE1 (D4 - D6): DPD TE input pin GAIN selection

D6	D5	D4	MODE (Relative value of DPDEQ1, 2 compared to the voltage)
0	0	0	6dB
0	0	1	9dB
0	1	0	12dB
0	1	1	15dB
1	0	0	18dB
1	0	1	21dB
1	1	0	24dB
1	1	1	27dB

PDLIMIT (D0 - D3): DPD PHASE DETECTOR's limit of output width

D3	D2	D1	D0	Limit of Width
0	0	0	0	160ns
≈				≈
1	1	1	1	10ns

· **Address 08H: Offset Adjustment**

ADDRESS	Data	Initial Value
08H	RFRP Offset	80H

The output OFFSET is at its minimum at 00H, maximum at FFH, and 2.5V at 80H.

· **Address 0AH:**

DATA	D7	D6	D5	D4	D3	D2	D1	D0
Function	EQ_FREQ							
Initial Value	1	0	0	0	0	0	0	0

EQ_FREQ (D0 - D7): EQ frequency characteristic's minute adjustment selection

EQ_FREQ	Amount of PEAK frequency change
22	+60%
≈	≈
80	0%
≈	≈
DB	-60%

Address 0BH :

DATA	D7	D6	D5	D4	D3	D2	D1	D0
Function	EQ_BOOST				ga-Mux-TE		EQG_CEN	
Initial Value	1	0	0	0	0	0	1	0

EQ_BOOST(D4 – D7) : GAIN minute adjustment selection from the EQ_BOOST GAIN chosen by EQG_CEN

D7	D6	D5	D4	CENTER GAIN change in width
0	0	1	0	-4dB
-				-
0	1	1	1	-0.5dB
1	0	0	0	0dB
1	0	0	1	+0.5dB
-				-
1	1	0	0	4dB

ga-Mux-TE(D2 - D3) : TE output gain control

D3	D2	CENTER_BOOST GAIN
0	0	10dB
0	1	12dB
1	0	14dB
1	1	16dB

EQG_CEN(D0 - D1) : EQ_BOOST GAIN's CENTER GAIN minute adjustment selection

D1	D0	CENTER_BOOST GAIN
0	0	3dB
0	1	5dB
1	0	7dB
1	1	9dB

Address 0CH :

DATA	D7	D6	D5	D4	D3	D2	D1	D0
Function	RFRP_FRQ		GAIN_RFRP		RFRP-LPF		SW-CON	SW_CON1
Initial Value	0	0	0	0	0	0	0	0

RFRP_FRQ (D6 - D7) : RFRP's PEAK-BOTTOM HOLD circuit output frequency, LPF frequency selection

D7	D6	RFRP FREQ.	RFRP LPF fc
0	0	30 kHz	60 kHz
0	1	80 kHz	160 kHz
1	0	160 kHz	320 kHz
1	1	320 kHz	640 kHz

GAIN_RFRP (D4 - D5) : RFRP's output GAIN selection

D5	D4	GAIN_RFRP
0	0	6dB
0	1	9.5dB
1	0	12dB
1	1	14dB

RFRP_LPF (D3 - D2): RFRP's output gain selection

D3	D2	RFRP_LPF
0	0	60kHz
0	1	80kHz
1	0	100kHz
1	1	120kHz

SW_CON (D1): Defect signal selection when RF AGC/AGC1 peaking protection selection

0: Un use

1: use

SW_CON1 (D0): Cpeak signal selection when RF AGC/AGC1 peaking protection selection

0: unuse

1: use

· **Address 0DH**

DATA	D7	D6	D5	D4	D3	D2	D1	D0
Function	AGC_LVL		DFTP_TH			DFT_TH		
Initial Value	0	1	0	0	0	0	0	0

AGC_LVL(D6 - D7) : RFAGC LEVEL selection

D7	D6	AGC LEVEL	Output Vpp
0	0	3.25V	0.50Vpp
0	1	3.5V	0.75Vpp
1	0	3.75V	1.00Vpp
1	1	4.0V	1.25Vpp

DFTP_TH(D3 - D5) : PLL DEFECT SLICE LEVEL selection

D5	D4	D3	SLICE LEVEL
0	0	0	300mV
0	0	1	400mV
0	1	0	500mV
0	1	1	600mV
1	0	0	700mV
1	0	1	800mV
1	1	0	900mV

1	1	1	1000mV
---	---	---	--------

DFT_TH(D0 - D2) : DEFECT SLICE LEVEL selection

D2	D1	D0	SLICE LEVEL
0	0	0	100mV
0	0	1	200mV
0	1	0	300mV
0	1	1	400mV
1	0	0	500mV
1	0	1	600mV
1	1	0	700mV
1	1	1	800mV

· **Address 0EH: Interrupt Threshold Level selection**

DATA	D7	D6	D5	D4	D3	D2	D1	D0
Function	INTER_TH							
Initial Value	1	0	0	0	0	0	0	0

Interrupt Level selection by the 8-Bit DAC

· **Address 0FH :FOK Threshold LEVEL selection**

DATA	D7	D6	D5	D4	D3	D2	D1	D0
Function	FOK_TH							
Initial Value	1	0	0	0	0	0	0	0

FOKB Level selection by the 8-Bit DAC

Address 10H

DATA	D7	D6	D5	D4	D3	D2	D1	D0
Function	INT_ONB	FLT_CTL	DFCT_CNST		LD_SEL	INT_SEL	AGC1_LVL	
Initial Value	0	0	0	0	0	0	0	0

AGC1_LVL(D0 - D1) : AGC1 output LEVEL adjustment selection

D1	D0	AGC1_LVL	Output LEVEL
0	0	2.9V	0.7V
0	1	3.0V	1.0V
1	0	3.1V	1.4V
1	1	-	-

INT_SEL (D2): Interruption input selection

- 0: Internal input
- 1: External input

LD_SEL(D3) : LD output selection

- 0 : Select LDDVD
- 1 : Select LDCD

DFCT_CNST(D4 - D5) : PEAK HOLD time constant selection for deciding the DEFECT circuit's DEFECT minimum detection width

D5	D4	DEFECT
0	0	60us/V
0	1	25us/V
1	0	12.5us/V
1	1	5.6us/V

FLT_CTL(D6) : Fault out output selection.

- 0: Fault out output ON
- 1: Fault out output OFF

INT_ONB(D7) : Interruption on/off selection.

- 0 : Interrupt Detect ON
- 1 : Interrupt Detect OFF

Address 11H

DATA	D7	D6	D5	D4	D3	D2	D1	D0
Function	RVSN	Vdc25_sel	VBGO_SEL	DVCTL_SEL	Vdc125_sel	AGC1_ON	GAIN_INT	
Initial Value	0	0	0	0	0	0	0	0

GAIN_INT(D0 - D1) : Interruption GAIN adjustment selection

D1	D0	GAIN	Drainage
0	0	3.5dB	X1.5
0	1	6dB	X2
1	0	9.5dB	X3
1	1	12dB	X4

AGC1_ON (D2) : AGC1 BLOCK ON/OFF adjustment selection

- 0 : AGC1 ON
- 1 : AGC1 OFF

Vdc125_sel (D3): 1.25V reference voltage selection

- 0: Bandgap voltage use
- 1: Reference voltage use

DVCTL_SEL (D4): TE1 input selection

- 0: (A+B), (B+D)
- 1: (A+D), (C+D)

VBGO_SEL (D5): ALPC reference voltage input selection

- 0: Internal bandgap reference voltage
- 1: External voltage

vdc25_sel (D6): 2.5V reference voltage selection

- 0: Bandgap voltage
- 1: Reference voltage

BLOCK DESCRIPTION

RF MULTIPLEXER

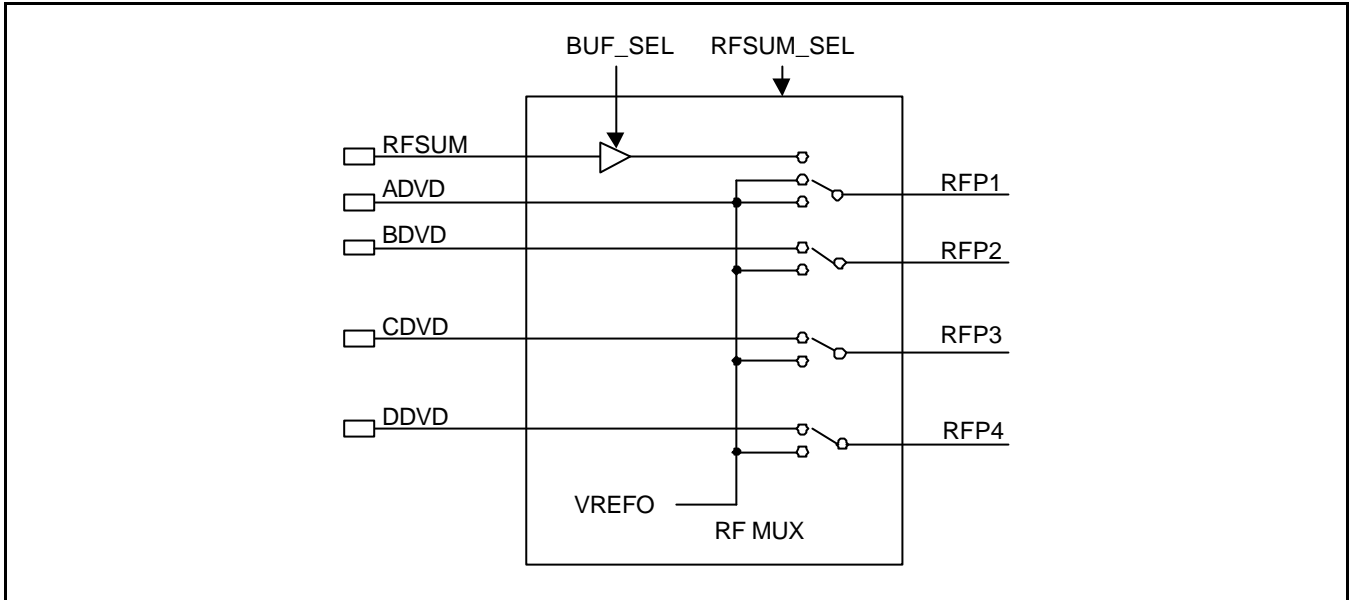

- The RF Multiplexer is a block that inputs into the RF SUM AMP the I/V signals which are output differently according to each pickup, in order to get the RF AUM signal. The RFSUM generates RF signals by compensating according to the I/V polarity using the ADDRESS 00H's BUF_SEL. The RF MUX's operation is selected by ADDRESS 00H's RFSUM_SEL REGISTER, and the RF MUX output value for each RFSUM_SEL are as follows.
- RFSUM_SEL (D3): Inputs and selects RFSUUM AMP's operation mode by Address 00H's (D5). (ABCD MUX & RFSUM)

D3	RFP1	RFP2	RFP3	RFP4
0	RFSUM	VREFO	VREFO	VREFO
1	ADVD	BDVD	CDVD	DDVD

RF SUM & AGC AMP BLOCK

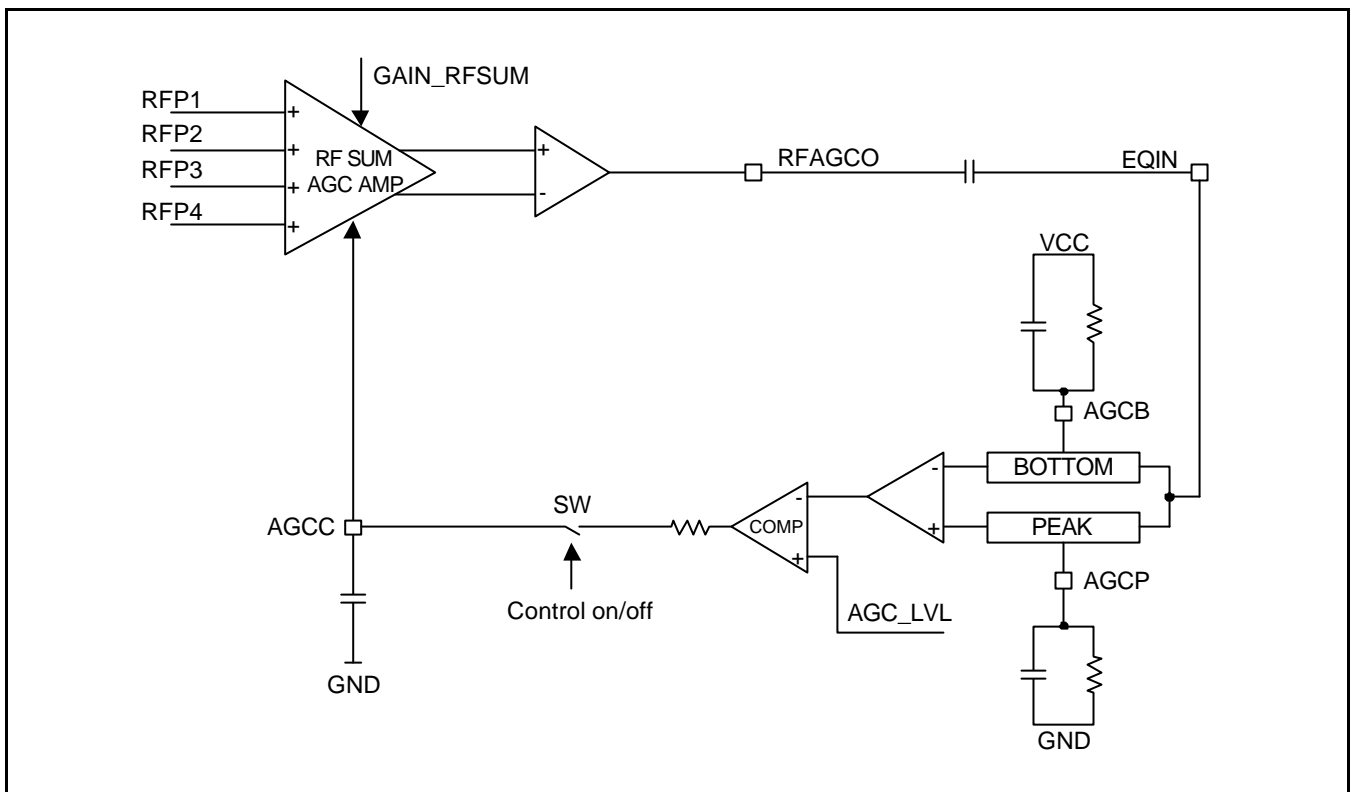

- The RF SUM AMP either adds or subtracts the input signal selected in the RF Multiplexer by the RFSUM_SEL and compensates according to the I/V polarity using ADDRESS 00H's BUF_SEL, to produce the RF signal. Also, the RF SUM AMP is able to adjust the LEVEL by the gain selected by GAIN_RFSUM (-6 – -16dB).
- The RF AGC circuit makes the signal whose gain was adjusted by the RFSUM AMP into a regular size. The AGC circuit's output size is selected according to the value of AGC_LVL (3.2V – 3.75V), between 0.5Vpp -- 1.25Vpp in increments of 0.25Vpp STEP. The AGC's response time constant is decided by the resistance capacity of the Capacitor connected to the external connection PIN (AGCP, AGCB, AGCC).
- SW is prohibited the peaking by hold the AGC voltage when meet the defect or interruption

RF EQUALIZER

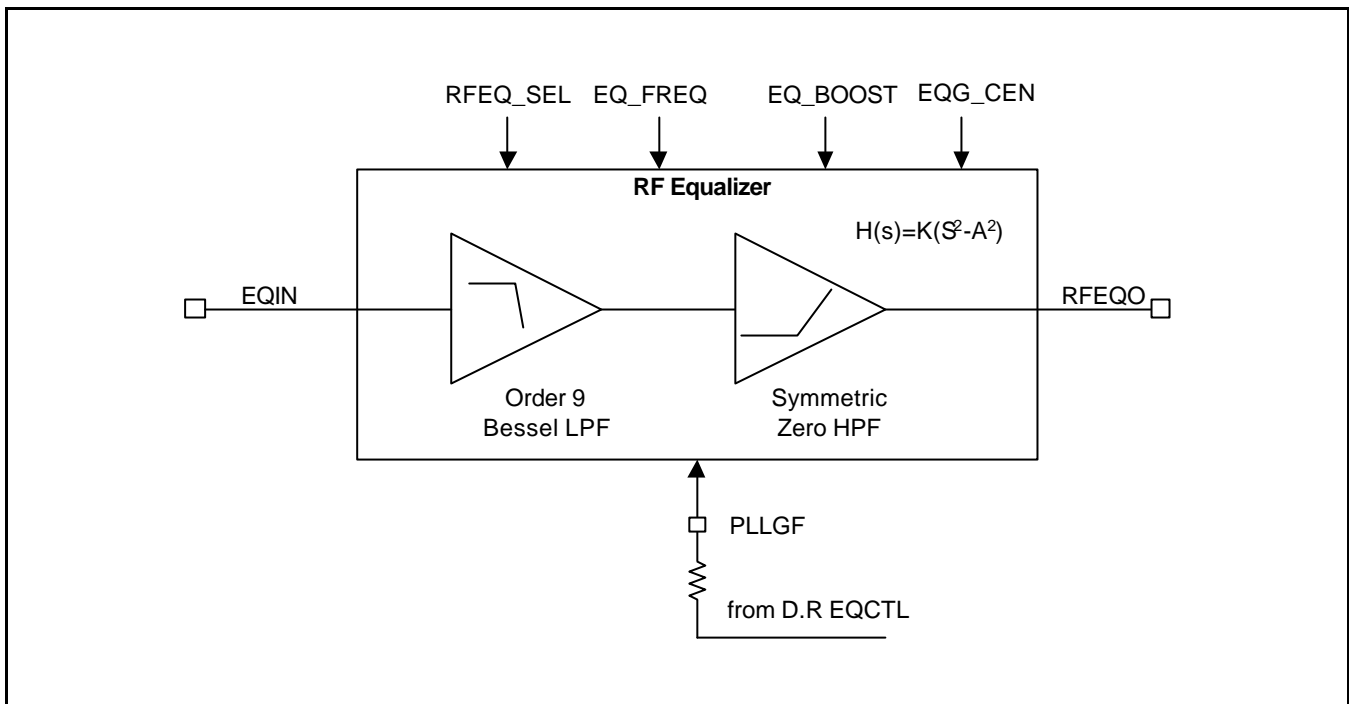

- The RF Equalizer receives the RF AGC AMP's output signal and corrects the gain and frequency characteristics according to disc type and speed. Our RF is used in common with the RF EQ that has similar frequency characteristics. The RF EQ has 3 independent EQ characteristics, namely that of DVD 1X, CD 1X, and CD 2X.
- The RF Equalizer is composed of the SYMMETRIC ZERO HPF and the 9th degree BESSEL LPF. The SYMMETRIC ZERO HPF's transmission function is:

$$H(s) = K(S^2 - A^2)$$
 and is combined with BESSEL LPF to make RF EQ characteristics.
- The RF EQ has predetermined frequency characteristics according to disc type and speed mode. The minute adjustments of frequency and BOOST gain are carried out by Add 0CH's EQ_FREQ and Add 0BH's EQ_BOOST and EQG_CEN. The gain adjustment of the Peaking frequency is carried out by the combination of GAIN (3-9dB, 2dB/STEP) selected by EQG_CEN, and GAIN (-4.0-+4.0dB, 0.5dB/STEP) selected by EQ_BOOST. The selection of the Peaking frequency is made by the EQ_FREQ.
- Of the RF EQ characteristics from SPEED_SEL selection, the characteristics when EQ_FREQ=0%, EQG_CEN=5dB, and EQ_BOOST=+1dB have been shown below.

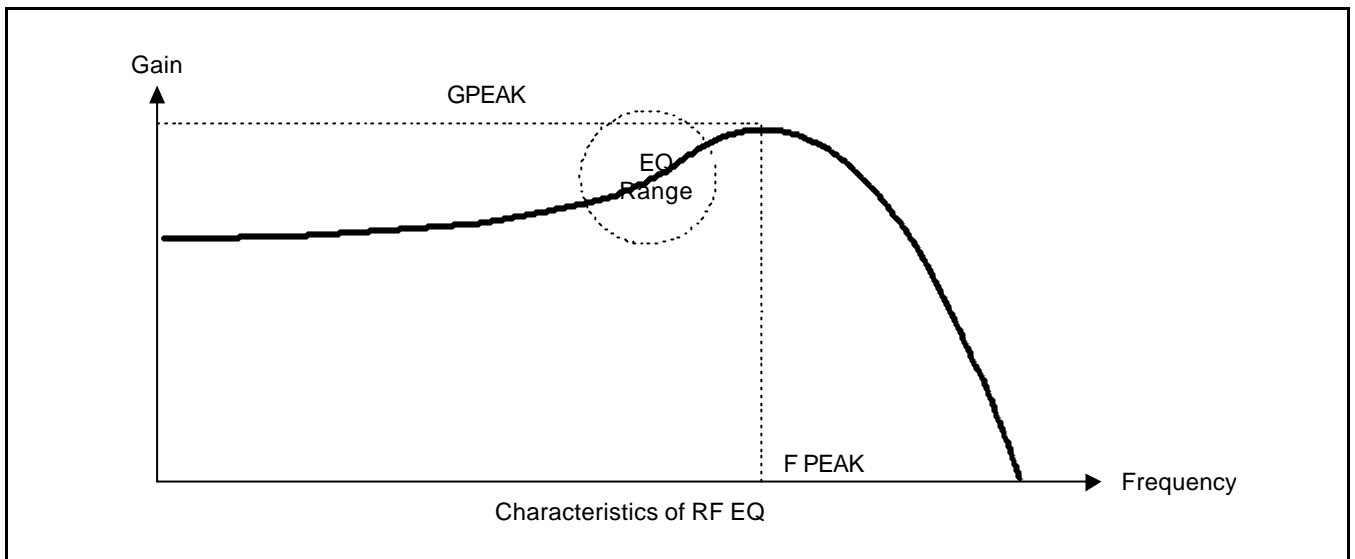

EQ_FREQ=0%, EQG_CEN=7dB, EQ_BOOST=0dB

SPPED_SEL	RF EQ	FPEAK	GPEAK
00	RF EQ1	6.4MHz	+7dB
10	RF EQ2	1.3MHz	+7dB
11	RF EQ3	2.6MHz	+7dB

The RF EQ's PEAK frequency is the same as shown in the above RF EQ characteristics. It is therefore able to adjust to the optimal EQ characteristics demanded by the SYSTEM by EQ_FREQ's minute tuning.

DPD TRACKING ERROR AMP

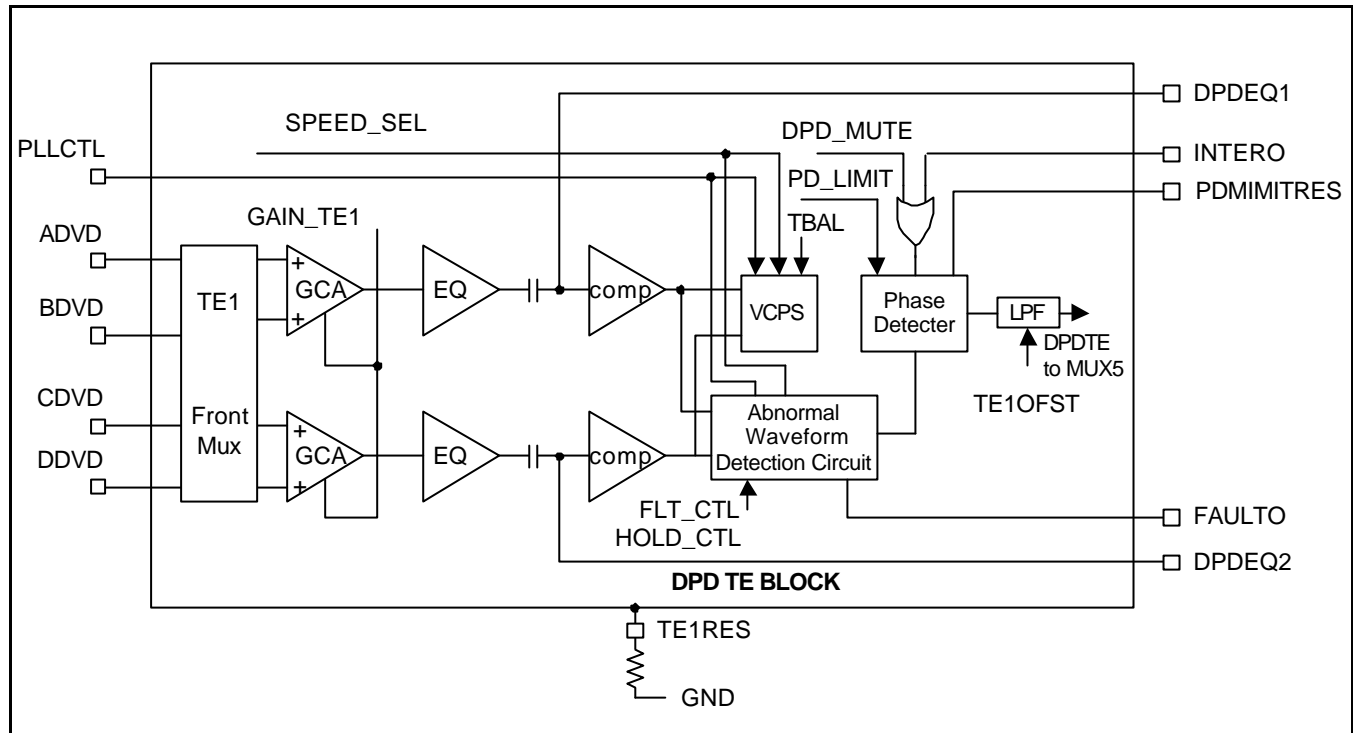

- The (A-D)DVD signal's gain is adjusted in the DPD input GAIN adjustment block by the gain selected by Address 07H's GAIN_TE1 register. The signal is then compensated in the DPD EQUALIZER and input into the COMPARATOR.
- The signal by passing through the COMPARATOR circuit is then adjusted for tracking balance by the VCPS (Voltage Controlled Phase Shift) circuit, whose Delay Time is adjusted by Address 01H's register TBAL.
- The signal, after passing through the VCPS circuit, detects the phase difference between two signals through the phase detector. The maximum width of the phase detector's output is limited by the output width limit set by Add 07H's PD_LIMIT register.
- The abnormal waveform detection circuit compensates for a small or unstable input signal. It executes mute when an abnormal waveform is detected, and turns the detection/compensation On or Off. The following are qualified as abnormal waveforms:
 - When the A+C COMPARATOR output is maintained for longer than 16T.
 - When the - B+D COMPARATOR output is maintained for longer than 16T
 - When the output of the abnormal waveform detection circuit goes "H".
 - When the output of the abnormal waveform detection circuit goes 'H', then goes back to "L" at the next RISING or FALLING EDGE.
- The output of the phase detector is output through the low pass filter. It is input into the MUX5 then output to the TE block.
- The DPD TE OFFSET is a function to correct the circuit OFFSET after phase comparison. It eliminates any OFFSET existing within the LPF block.
- The DPD MUTE mutes the DPD TE while correcting the DPD Offset. Mute is carried out when Add 07H's DPD_MUTE register is "H", the external DPDMUTE block's input voltage is "H", and the INTERRUPT output is "H".
- When TE_SEL is not in DPD MODE, the DPD BLOCK's power is turned off.

3B TE AMP AND TE OUTPUT SELECTION

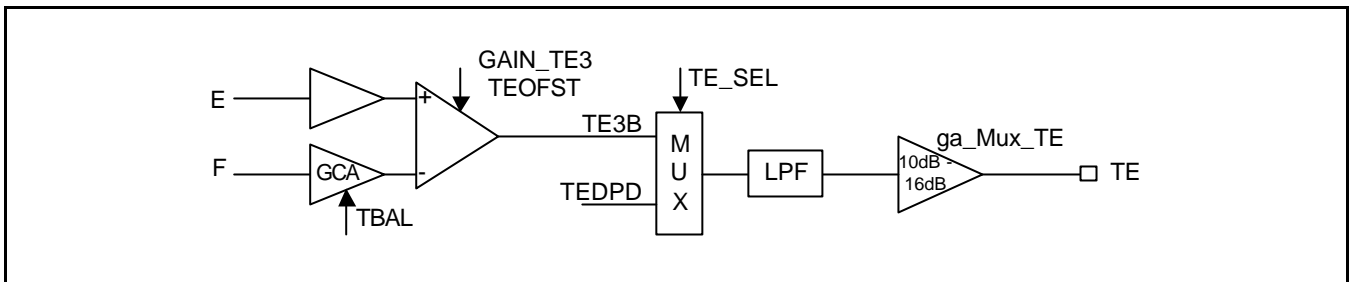

- Tracking Balance is carried out in the following manner. The GAIN of the F signaling AMP is adjusted by the T_BAL (Tracking Balance) so that the AC level of the E, F signal input becomes the same.
- After the BALANCE has been adjusted, the E,F signal is operated on in the 3-Beam Tracking Error Amp by $TE = k(E-F)$. Then the GAIN is compensated by Address 02H's GAIN_TE3 from 6dB - 20dB to compensate for the difference in disc reflectivity according to disc type. The OFFSET is compensated by TEOFST, and the signal is output as a TE3B signal.
- The TE3B signal is output when the TE_SEL selects either the DPD TE or the 3B TE output.
- The MUX TE output signal is output through the LPF ($f_c=20.4\text{kHz}$) and the 10dB Amp.
- The Servo Control voltage output is compatible with the 3.3V Supply.

FOCUS ERROR AMP

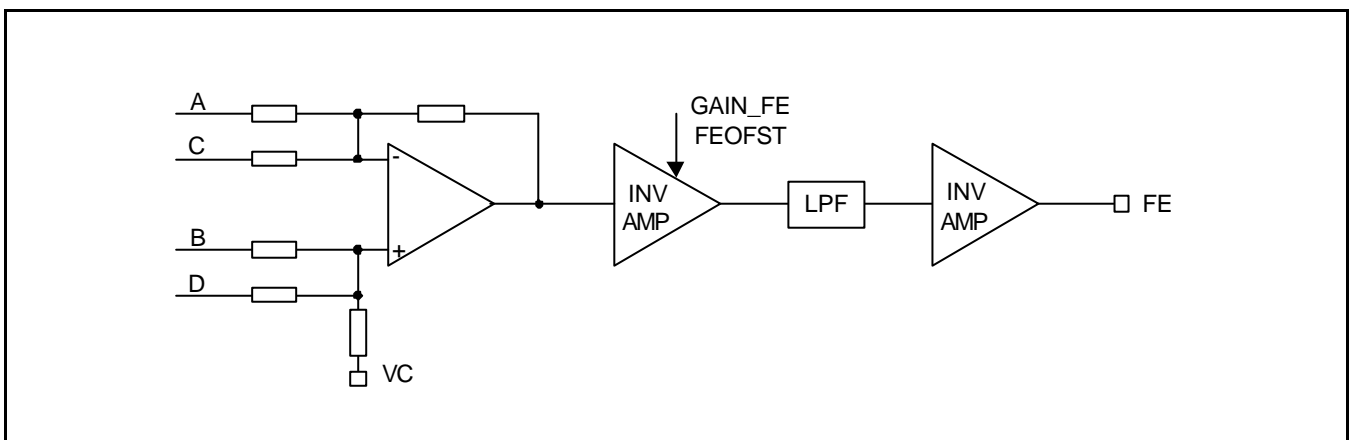

- The $(A+C)$, $(B+D)$ input signal is operated on in the FOCUS Error Amp by $FE = -k((A+C)-(B+D))$. The gain is compensated by Address 03H's FE_GAIN from -2dB - +28dB to account for the difference in disc reflectivity according to disc type. When the OFFSET is adjusted by FEOFST, the signal is output as an FE signal after passing through the LPF ($f_c=34.7\text{kHz}$) and the Inversion AMP.
- The output is a Servo Control voltage and is compatible with the 3.3V Supply.

ABCD SUM AMP

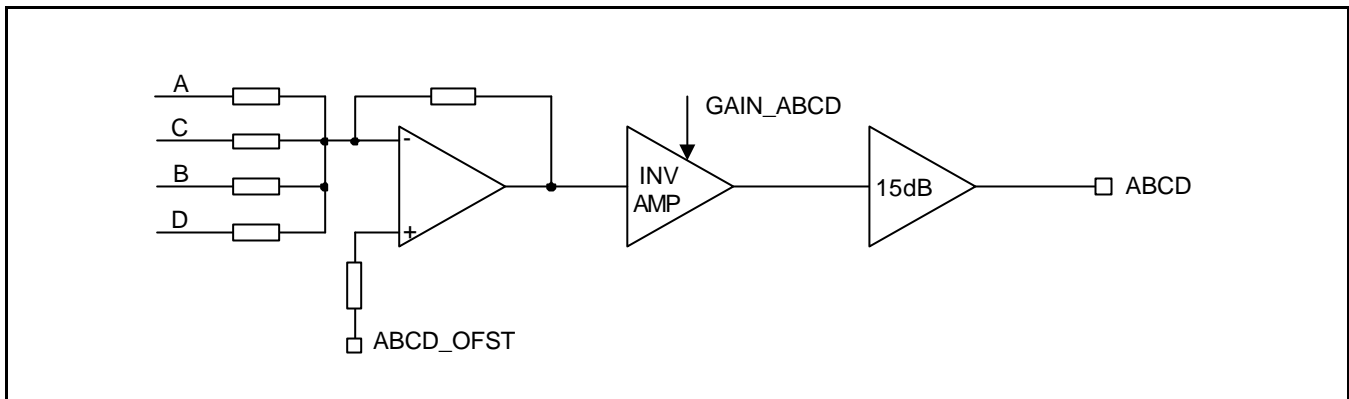

- The input signals A, B, C, D are operated as $ABCD = A+B+C+D$ in the ABCD SUM Amp. The gain is compensated by Address 03H's GAIN_ABCD from 0dB - +30dB to account for the difference in disc reflectivity according to disc type. The OFFSET is adjusted by the BACDOFST, then the signal is output as ABCD.
- The frequency characteristics of the output AMP are $f_c = 4\text{MHz}$ when in CD 2x mode, and $f_c=10\text{MHz}$ in DVD mode.

FOK DETECT CIRCUIT

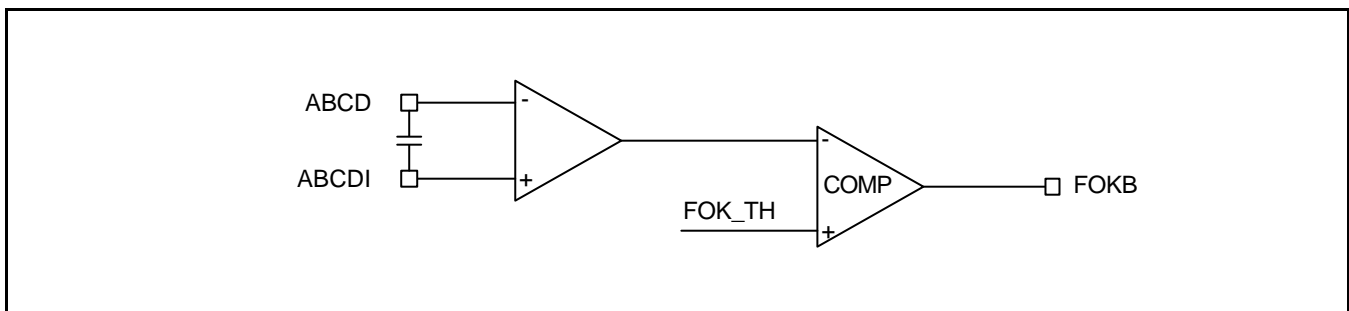

- This circuit generates the FOCUS OK signal for the SERVO. It consists of a circuit that detects the PEAK of the ABCD SUM signal, and the circuit that outputs the FOKB signal.
- It compares and outputs the ABCD SUM signal's output signal and the comparison LEVEL(FOK_TH).

MIRROR CIRCUIT

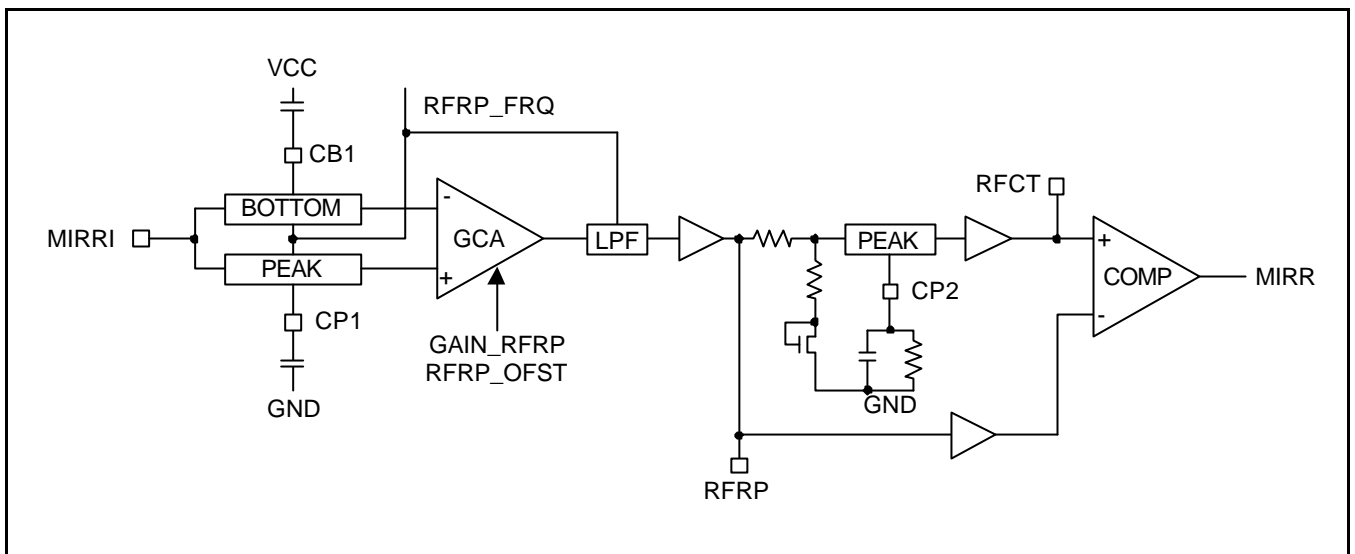

- The RFRP circuit is a block that detects signals crossing the TRACK.
- The circuit receives AC-COUPLED RFRAGCO signals and calculates the difference between two signals through the PEAK HOLD and BOTTOM HOLD. The response time constant of the PEAK HOLD and BOTTOM HOLD is set by Add 0CH's RFRP_FRQ, and the standard CAPACITOR value is set by the CP1 block and CAPACITOR connected to the CB1 block. (Standard value: 100pF)
- The AMP that produces the RFRP signal by calculating the PEAK HOLD output and the BOTTOM HOLD output receives the RFRP_OFST, and corrects the difference in DC value in the PEAK HOLD output and BOTTOM HOLD output to guarantee a DYNAMIC RANGE and adjust the gain by GAIN_RFRP from 0dB-12dB.
- The RFRP signal is output through the R, C 1st LPF, and the LPF's BW is decided by Address 0CH's RFRP_FRQ value.
- The CENTER voltage of the two signals that passed through the PEAK HOLD and BOTTOM HOLD is output to the RFCT block. The response time constant of the PEAK HOLD and BOTTOM HOLD is decided by the CAPACITOR value and resistance connected to CP2 and CB2.
- The MIRR signal is found by comparing the RFCT and RFRP signal, and the polarity is HIGH in the MIRROR while LOW in the PIT. Also, the amount of HYSTERISIS can be adjusted by inserting resistance between the RFCT and MIRR.

RF ENVELOPE CIRCUIT

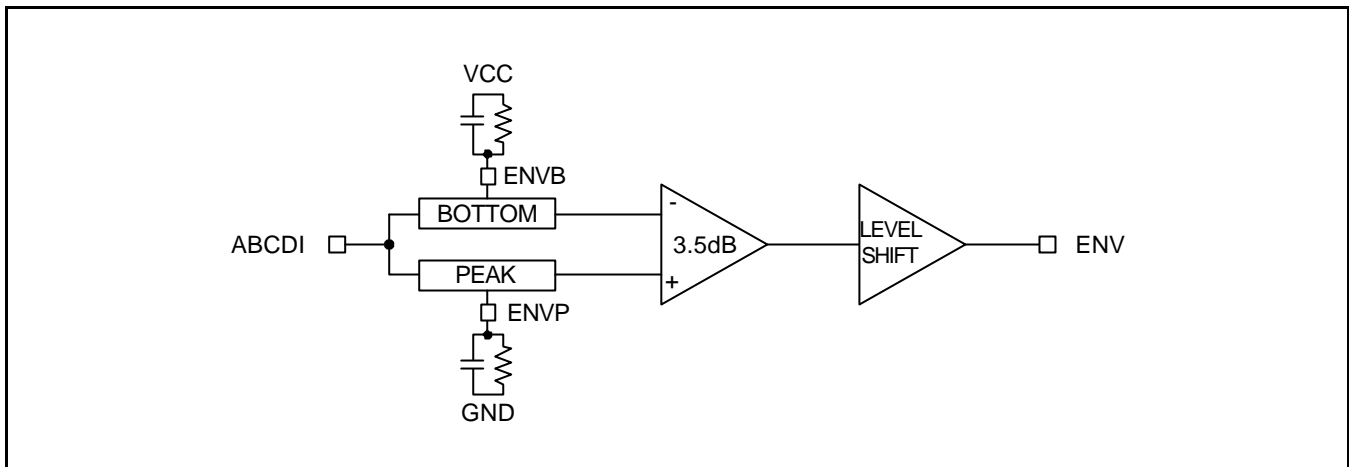

- This circuit detects the RF ENVELOPE RF signal's ENVELOPE. It has the ENVELOPE detection output for adjusting the SERVO's FOCUS BIAS.
- The PEAK HOLD and BOTTOM HOLD's response time constant is decided by the CAPACITOR value connected to the external block ENVP, ENVB, and the standard response frequency is 10 kHz (when $C = 0.01\mu\text{F}$).
- The LEVEL SHIFT circuit is to make sure ENVOUT starts near 0Volts instead of at V_c LEVEL when there is no RF signal.
- During Focus Un-locking, the circuit outputs to the ENV output block after 3.5dB GAIN UP.
- The ENV signal is output to the ENV output block during Focus Un-locking after 3.5dB GAIN UP.

DEFECT DETECT CIRCUIT

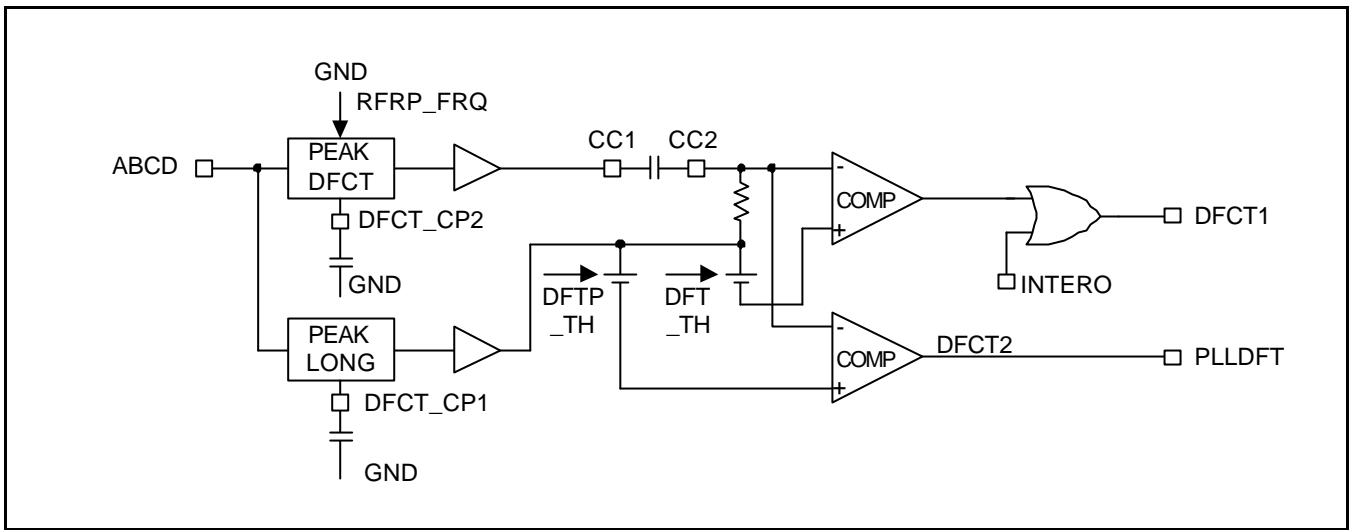

- The DEFECT circuit detects the signal defects from damage to the reflective surface. The defects are detected in ABCD through high speed PEAK HOLD and low speed PEAK HOLD. DC is added to the high speed PEAK HOLD output, then compared with the low speed PEAK HOLD output.
- The high speed PEAK HOLD's response time constant is set to Add 0CH's RFRP_FRQ when a DEFECT is detected. The low speed PEAK HOLD time constant is set by the CAPACITOR connected to the RFRP_FRQ and CB_DFT block. The rate of change is same for high and low speed PEAK HOLD.
- The DEFECT detecting level for SERVO is set by Add 0DH's DFT_TH, and the DEFECT detecting level for PLL is set by DFTP_TH. The output of the SERVO's DEFECT is ORING with the INTERRUPT output.

INTERRUPT DEFECT CIRCUIT

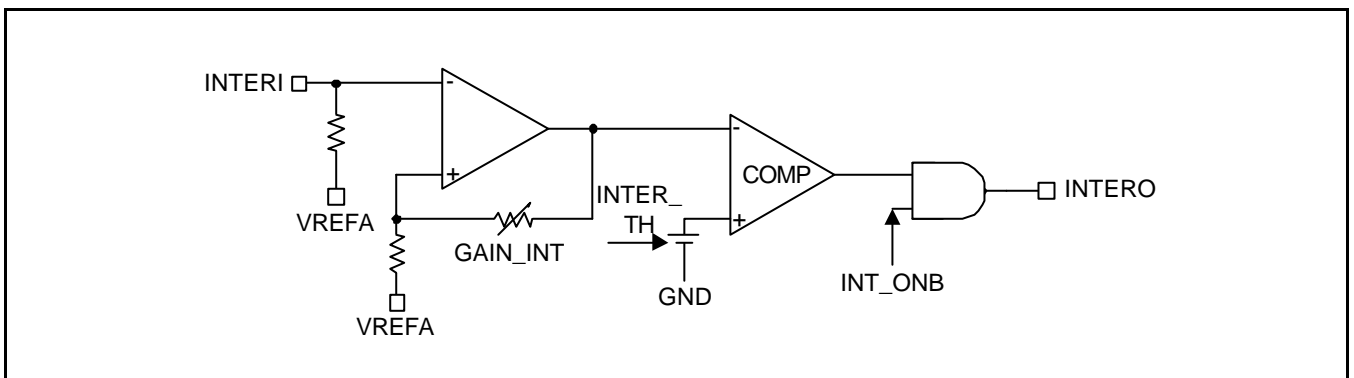

- The Interrupt DEFECT circuit detects signal defects from insulation layer damage during CD/DVD Mode operation. The ABCDSUM output passes through the external LPF, is amplified by the AMP, then comparatively output with the Comparator's standard voltage (INTER_TH). The AMP's GAIN is adjusted by the GAIN_INT, and this interrupt signal's use is determined by INT_ONB.

ALPC CIRCUIT

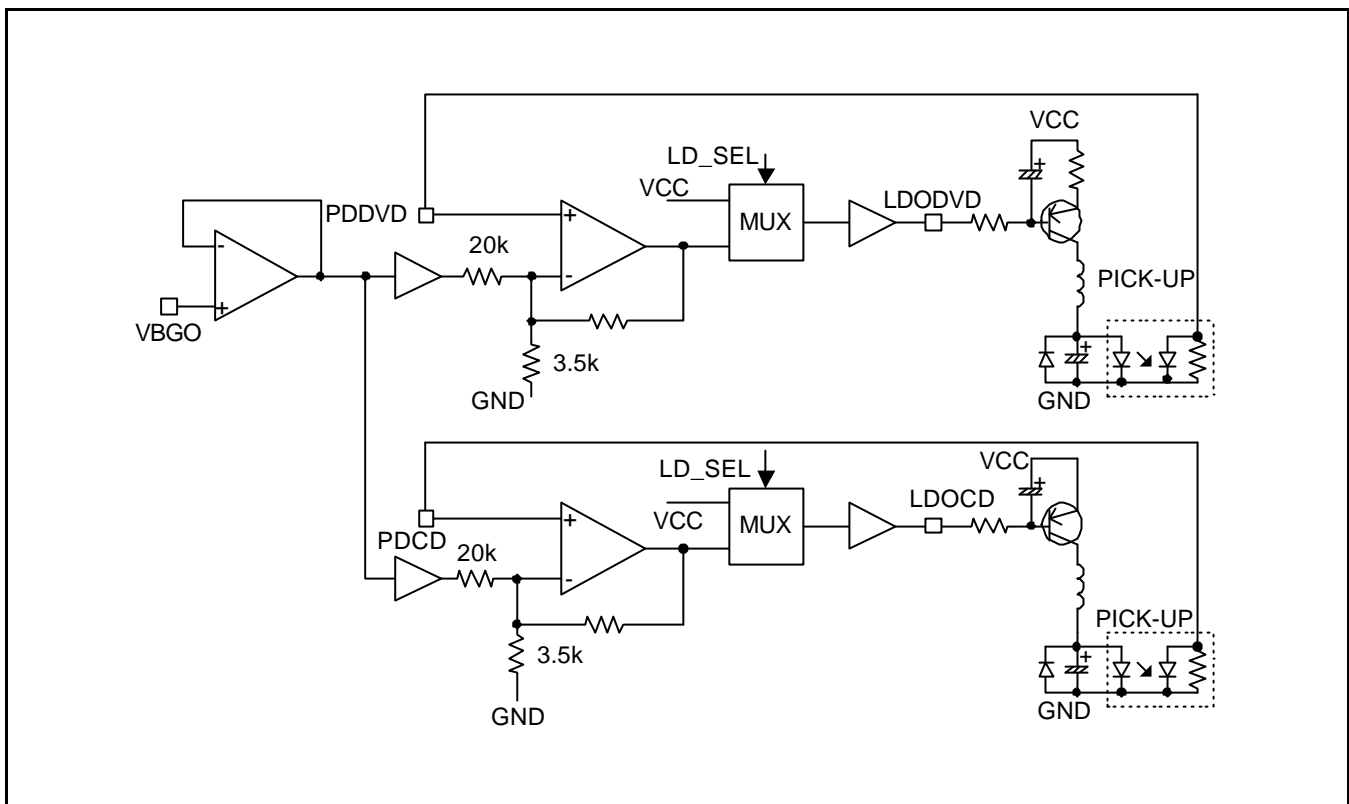

- This circuit is for controlling the Laser Diode's amount of light. It sets the amount of light that is output during playback, and stabilizes it by detecting the fluctuation in Laser Power for voltage or temperature change using the Monitor Photo Diode's output current change.
- ALPC for CD and DVD are separate. ALPC circuit selection and On/Off are controlled by Add 00H's LDONB. The unselected ALPC maintains Off status.
- The ALPC reacts to the P-SUB LASER DIODE. Its standard voltage can be changed by the value of the external ZENER DIODE connected to the VREFLP_BGI block.
- PD's standard input voltage range is 100mV -- 0.5V.

TEST CIRCUIT

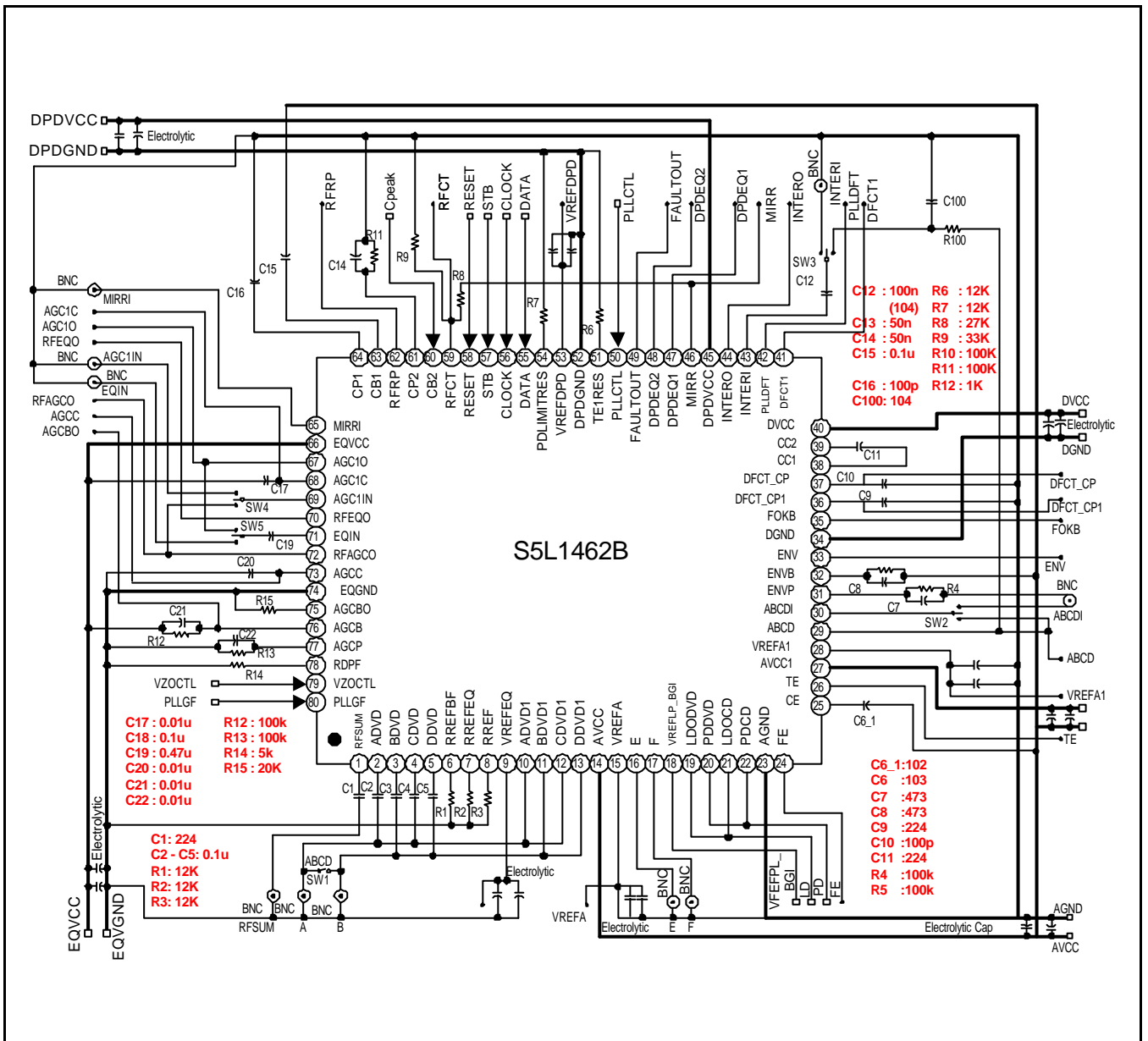

PACKAGE DIMENSION

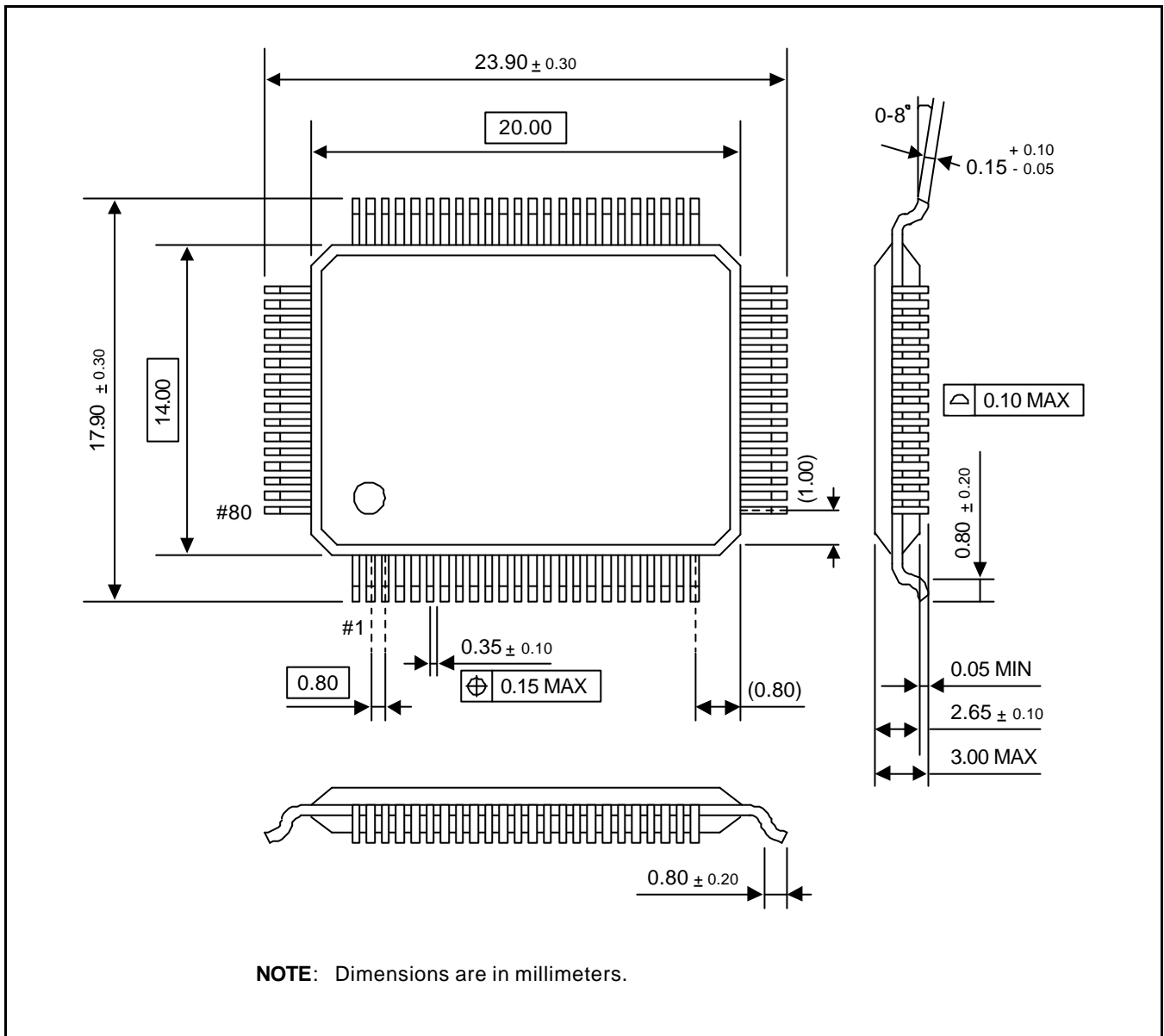

NOTES