

INTRODUCTION

The S1T8503 is a low voltage speech network which includes Mic amp, transmit amp, side-tone amp, and receive amp. It handles the voice signal performing the 2/4 wire interface and changing the gain on both sending and receiving amplifiers to compensate for line attenuation by sensing the line length through the line current.

Application dependent parameters such as amplitude of each amp, sidetone level, line balance and frequency response are controlled by external components. Each gain can be controlled by external component exchange. The receiver output driving capability is adjustable.

18-DIP-300A

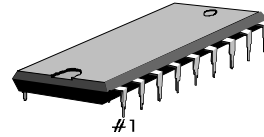

FEATURES

- Adjust Sending and Receiving Attenuation Length
- Mute Function
- Side Tone Balance Network Constitution
- Low Voltage Operating
- AC Impedance Matching
- Uses Inexpensive Components
- Uses a minimum of external components (5 Capacitors & 10 Resistors)

ORDERING INFORMATION

Device	Package	Operating Temperature
S1T8503X01-D0B0	18-DIP-300A	- 40°C to + 70°C

BLOCK DIAGRAM

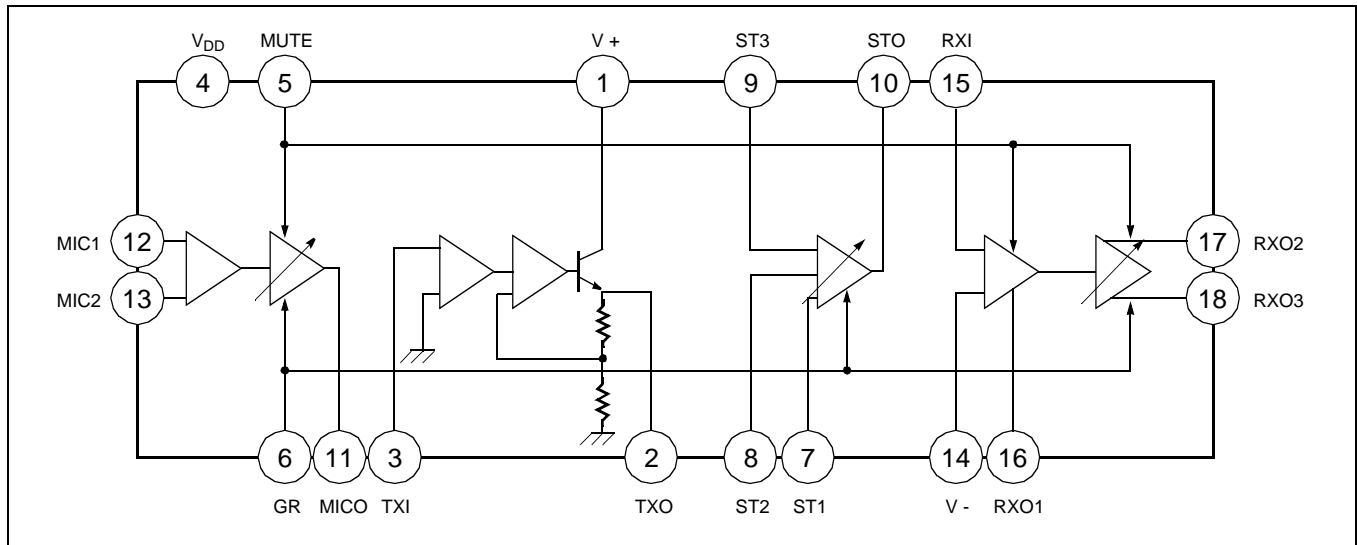

PIN CONFIGURATION

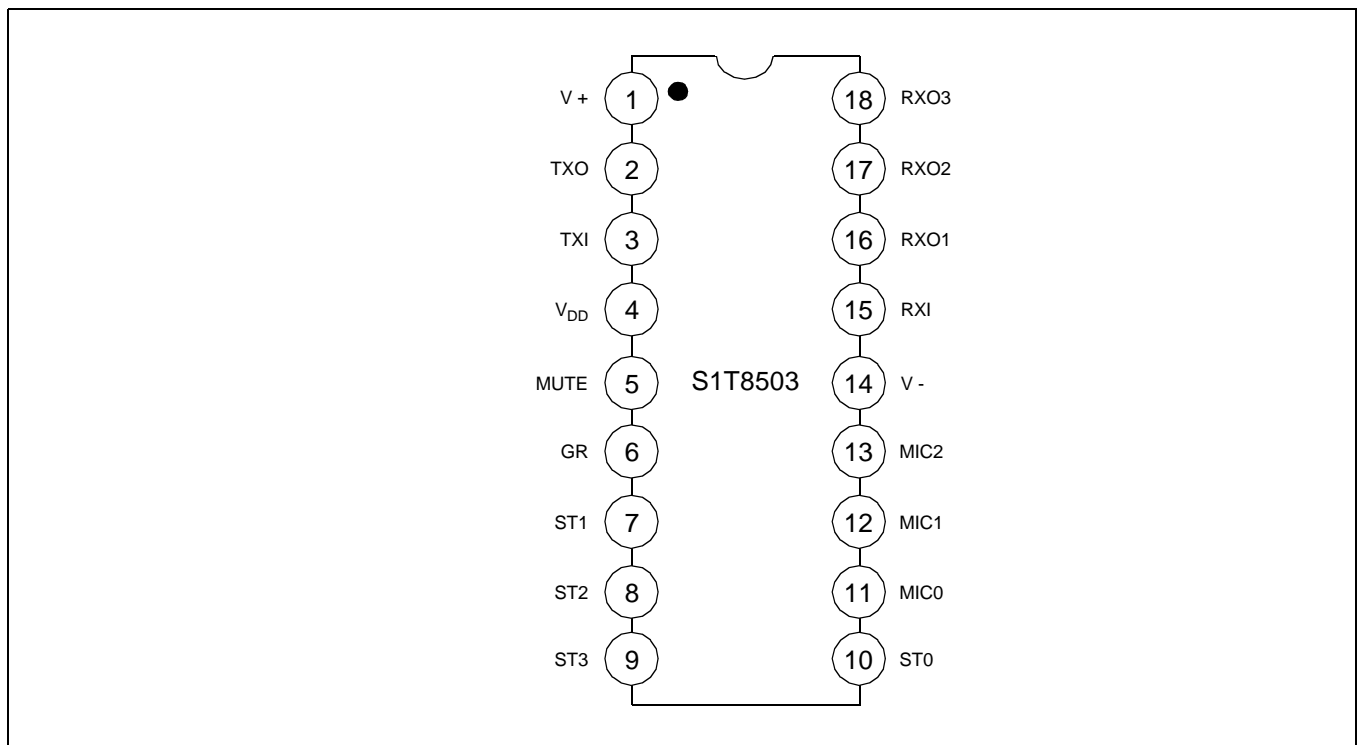

PIN DESCRIPTION

Pin No	Symbol	Description
1	V +	Positive power line and transmit amplifier output.
2	TXO	Transmit amplifier output. The resistor which is connected this pin to V – sets the DC resistance of circuit. The value of resistor is suitable for 47 to 100Ω.
3	TXI	Transmit amplifier input. Input impedance is 17kΩ ± 20%
4	V _{DD}	DC power supply pin. This pin will be connected to a decoupling capacitor 47μF - 100 μF.
5	MUTE	Mute input : Active high .
6	GR	Gain regulation control input. Input impedance is 5.5kΩ ± 20%.
7, 8, 9	ST1, ST2, ST3	Separate amplifier control inputs.
10	STO	Separate amplifier output.
11	MIC0	Microphone amplifier output.
12, 13	MIC1, MIC2	Microphone amplifier inputs. Input impedance is 1.7kΩ ± 20%
14	V –	Negative power line.
15	RXI	Receive amplifier input.
16	RXO1	Receive amplifier output.
17, 18	RXO2, ROX3	Receive amplifier output. Output impedance is 3Ω(Typ)

ABSOLUTE MAXIMUM RATINGS

Characteristic	Symbol	Value	Unit
Line Voltage (3ms max)	V _L	22	V
Forward Line Current	I _{LF}	150	mA
Reverse Line Current	I _{LR}	-150	mA
Power Dissipation (Ta = 70°C)	P _D	1	W
Operating Temperature	T _{OPR}	-40 to + 70	°C
Storage Temperature	T _{STG}	-55 to + 125	°C

ELECTRICAL CHARACTERISTICS

(Refer to the test circuits, $I_L = 15$ to 100mA , $f = 200$ to 3.4kHz , $T_a = 25^\circ\text{C}$, unless otherwise specified)

Characteristic	Symbol	Test Conditions		Test Fig	Min.	Typ.	Max.	Unit
Line Voltage	V_L	$I_L = 15\text{mA}$	$I_L = 15\text{mA}$		3.3	3.7	4.1	V
		$I_L = 100\text{mA}$	$I_L = 100\text{mA}$		11	13	15	
T_X Gain	$G_{V(TX)}$	$V_{MI} = 5\text{V}$ $f = 1\text{kHz}$	$I_L = 20\text{mA}$	1	46	48	50	dB
			$I_L = 38.5\text{mA}$		43.5	45.5	47.5	
			$I_L = 55\text{mA}$		41	43	45	
TX Range of Regulation	ΔG_{TX}	$\Delta G_{TX} = G_{TX1} - G_{TX3}$			3	5	7	dB
TX Frequency Response	$\Delta G_{TX(RES)}$	$V_{MI} = 5\text{mV}$ $I_L = 20\text{mA}$	$f = 200\text{Hz}$	1	-	-	± 1	dB
			$f = 3.4\text{kHz}$		-	-	± 1	
		$V_{MI} = 5\text{mV}$ $I_L = 80\text{mA}$	$f = 200\text{Hz}$	1	-	-	± 1	
			$f = 3.4\text{kHz}$		-	-	± 1	
TX Dynamic Output Voltage	$V_{O(TX)}$	$I_L = 20\text{mA}$, $f = 200\text{Hz}$ to 3.4kHz		1	-	1.5	-	Vp-p
		$I_L = 100\text{mA}$, $f = 200\text{Hz}$ to 3.4kHz			-	1.5	-	
TX Max Output Voltage	$V_{OTX(MAX)}$	$I_L = 20\text{mA}$, $f = 200\text{Hz}$ to 3.4kHz		1	-	1.5	-	Vp-p
		$I_L = 100\text{mA}$, $f = 200\text{Hz}$ to 3.4kHz			-	1.5	-	
TX Input Impedance	$Z_I(TX)$	$I_L = 20\text{mA}$, $f = 200\text{Hz}$ to 3.4kHz			-	1.7	-	$k\Omega$
Mute Input Current	$I_I(MUTE)$	$I_L = 20\text{mA}$	$I_M = 0.1\text{mA}$		0.1	-	-	mA
RX Gain	$G_{V(RX)}$	$V_{RI} = 0.5\text{V}$ $f = 1\text{kHz}$	$I_L = 20\text{mA}$	2	-13.5	-11.5	-9.5	dB
			$I_L = 38.5\text{mA}$		-16	-14	-12	
			$I_L = 55\text{mA}$		-18.5	-16.5	-14.5	
RX Range of Regulation	ΔG_{RX}	$\Delta G_{RX} = G_{RX1} - G_{RX3}$			3	5	7	dB
RX Frequency Response	$\Delta G_{RX(RES)}$	$V_{RI} = 0.5\text{V}$ $I_L = 20\text{mA}$	$f = 200\text{Hz}$	2	-	-	± 1	dB
			$f = 3.4\text{kHz}$		-	-	± 1	
		$V_{RI} = 0.5\text{V}$ $I_L = 80\text{mA}$	$f = 200\text{Hz}$	2	-	-	± 1	
			$f = 3.4\text{kHz}$		-	-	± 1	
RX Dynamic Output Voltage	$V_{O(RX)}$	$I_L = 20\text{mA}$	$f = 200\text{Hz}$	2	0.3	0.5	-	Vp-p
			$f = 3.4\text{kHz}$		0.3	0.5	-	
		$I_L = 100\text{mA}$	$f = 200\text{Hz}$		0.3	0.5	-	
			$f = 3.4\text{kHz}$		0.3	0.5	-	
RX Max Output Voltage	$V_{ORX(MAX)}$	$I_L = 20\text{mA}$ $V_{RI} = 10\text{V}$	$f = 200\text{Hz}$	2	-	0.9	-	Vp-p
			$f = 3.4\text{kHz}$		-	0.9	-	

TEST CIRCUIT

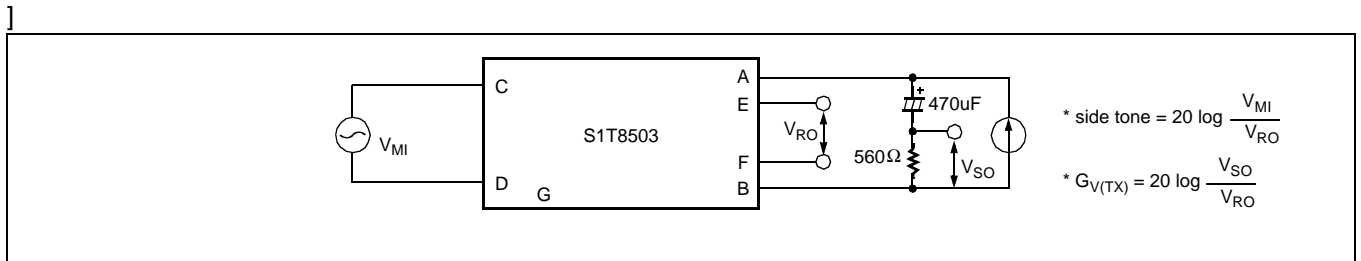
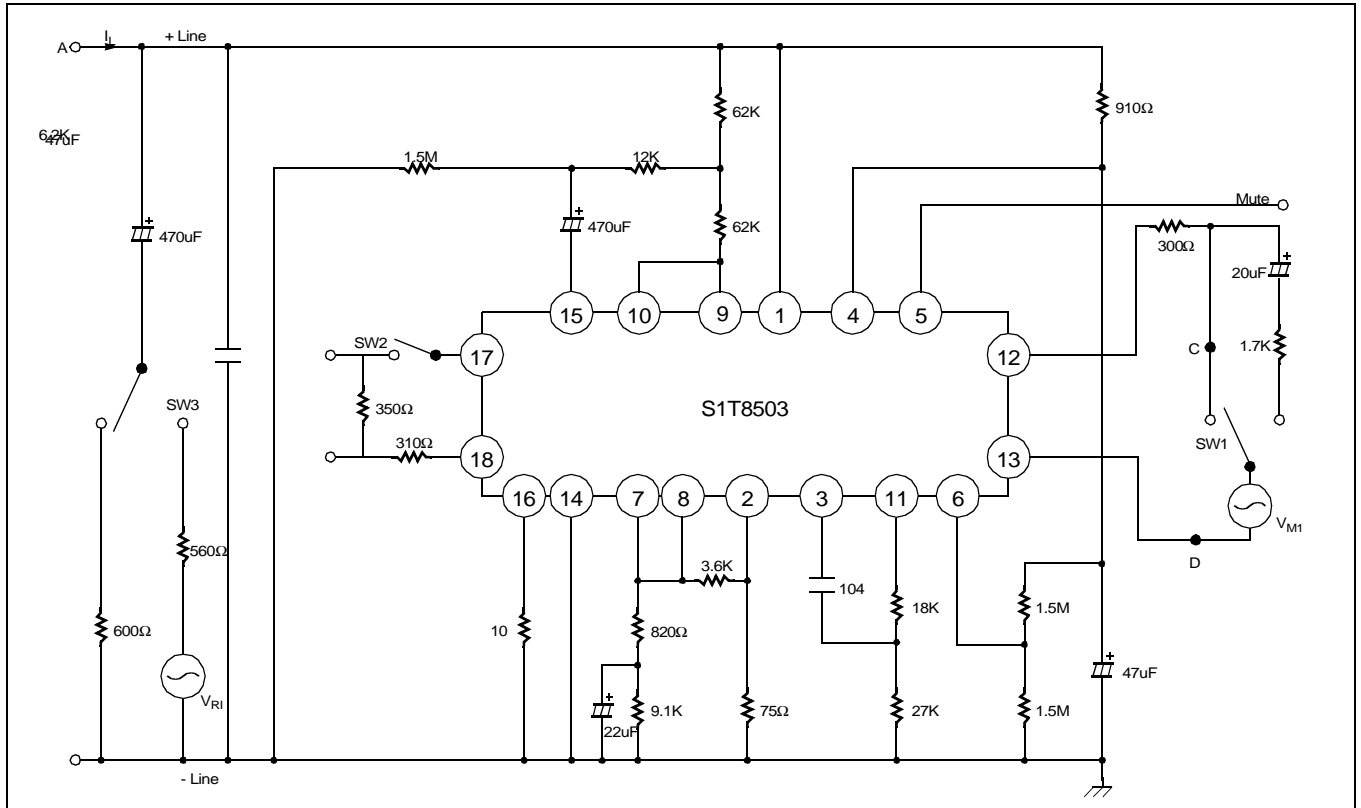

Figure 1.

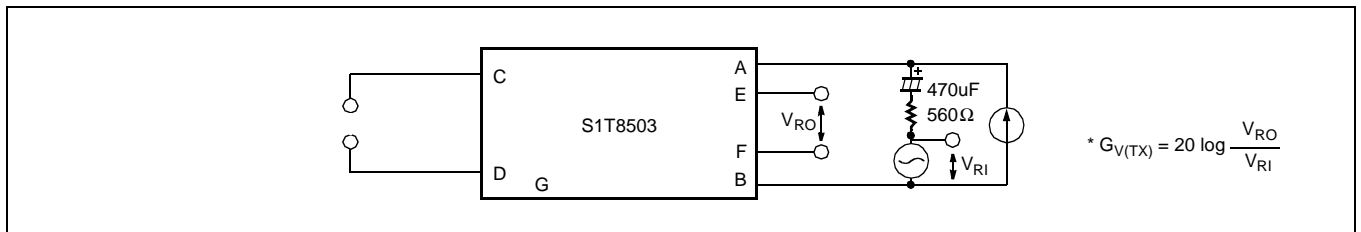

Figure 2.

NOTES