

INTRODUCTION

The S1T8501 is a speech network integrated circuit which includes the following components: transmit amp, receive amp, DTMF amp, voltage regulator, line equalizer, and voltage comparator. It handles the voice signal, performing the 2/4 wires interface and changing the gain on both sending and receiving amplifiers to compensate the line current. The S1T8501 can work in fixed gain mode.

FEATURES

- Adjusts sending and receiving attenuation length
- Regulated voltage output for external dialer
- Linear interface for DTMF
- Suitable for ceramic transducers
- Mute function

ORDERING INFORMATION

Device	Package	Operating Temperature
S1T8501X01-D0B0	16-DIP-300A	-45°C — +70°C

16-DIP-300A

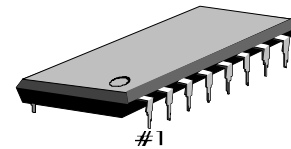

PIN CONFIGURATION

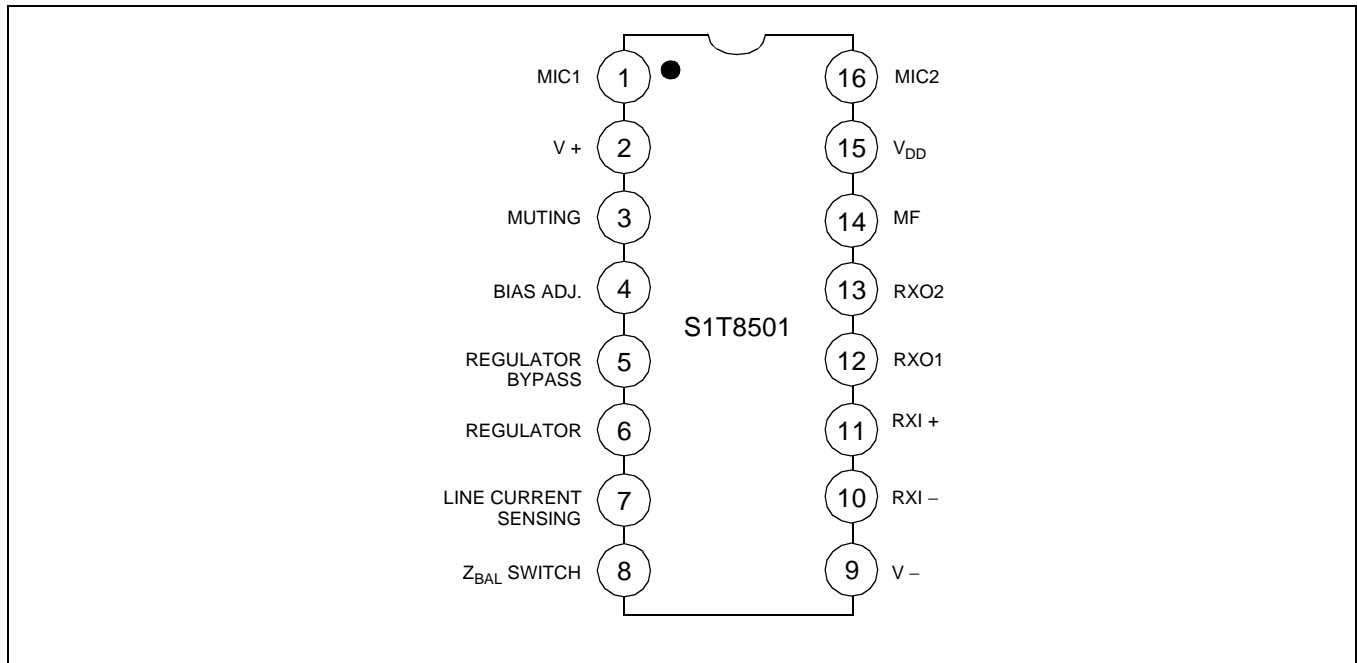

ABSOLUTE MAXIMUM RATINGS

Characteristic	Symbol	Value	Unit
Line Voltage (3msec max)	V_L	22	V
Forward Line Current	I_{LF}	150	mA
Reverse Line Current	I_{LR}	-150	mA
Power Dissipation ($T_a = 70^\circ\text{C}$)	P_D	1	W
Operating Temperature	T_{OPR}	- 45 — + 70	$^\circ\text{C}$
Storage Temperature	T_{STG}	- 65 — + 150	$^\circ\text{C}$

ELECTRICAL CHARACTERISTICS (TA = 25°C)

Characteristic	Symbol	Test Conditions		Min.	Typ.	Max.	Unit	
Line Voltage	V_L	Ta = 25°C	$I_L = 12\text{mA}$	3.9	–	4.7	V	
			$I_L = 20\text{mA}$	–	–	5.5		
			$I_L = 80\text{mA}$	–	–	12.2		
Common Mode Rejection Ratio	CMRR	f = 1kHz, $I_L = 12$ to 80mA		50	–	–	dB	
Line Matching Impedance	Z_L	$V_{RI} = 0.3\text{V}$, $I_L = 12$ to 80mA f = 1kHz		500	600	700	Ω	
TX Gain	$G_{V(TX)}$	Ta = 25°C f = 1kHz VMI = 2mV	$I_L = 25\text{mA}$	48	49	50	dB	
			$I_L = 52\text{mA}$	44	45	46		
			$I_L = 25$ to 52mA	48	49	50		
TX Gain Flatness	$\Delta G_{V(TX)}$	$V_{MI} = 2\text{mV}$, $f_{ref} = 1\text{kHz}$, $I_L = 12$ to 80mA		–	–	± 1	dB	
TX Distortion	THD _{TX}	f = 1kHz $I_L = 16$ to 80mA	$V_{SO} = 1\text{V}$	–	–	2	%	
			$V_{SO} = 1.3\text{V}$	–	–	10		
TX Noise	$V_{NO(TX)}$	$V_{MI} = 0\text{V}$, $I_L = 40\text{mA}$		–	–	–70	dBm	
Side Tone	$G_{V(ST)}$	Ta = 25°C, f = 1kHz, $I_L = 25$ to 52mA		–	–	36	dB	
MIC Input Impedance	$Z_I(MIC)$	$V_{MI} = 2\text{mV}$, $I_L = 12$ to 80mA		40	–	–	k Ω	
Tx Loss in MF Operation	$G_{V(LOSS)}$	$V_{MI} = 2\text{mV}$	$I_L = 25\text{mA}$	–30	–	–	dB	
			$I_L = 52\text{mA}$	–30	–	–		
RX Gain	$G_{V(RX)}$	Ta = 25°C $V_{RI} = 0.3\text{V}$ f = 1kHz	$I_L = 25\text{mA}$	7	8	9	dB	
			$I_L = 52\text{mA}$	2.5	3.5	4.5		
			$I_L = 25$ to 52mA	7	8	9		
RX Gain Flatness	$\Delta G_{V(RX)}$	$V_{RI} = 0.3\text{V}$, $f_{ref} = 1\text{kHz}$, $I_L = 12$ to 80mA		–	–	± 1	dB	
RX Distortion	THDRX	f = 1kHz	$I_L = 12\text{mA}$	$V_{RO} = 1.6\text{V}$	–	–	2	%
				$V_{RO} = 1.9\text{V}$	–	–	10	
			$I_L = 50\text{mA}$	$V_{RO} = 1.8\text{V}$	–	–	2	
				$V_{RO} = 2.1\text{V}$	–	–	10	
RX Noise	$V_{NO(RX)}$	$V_{RI} = 0\text{V}$, $I_L = 12$ to 80mA		–	–	100	μV	
RX Output Impedance	$R_{O(RX)}$	$V_{RO} = 50\text{mV}$, $I_L = 40\text{mA}$		–	–	100	Ω	
MF Supply Voltage	$V_{DD(MF)}$	$I_L = 12$ to 80mA		2.4	2.5	–	V	
MF Supply Current	Standby	$I_{SB(MF)}$	$I_L = 12$ to 80mA	0.5	–	–	mA	
	Operation	$I_{DD(MF)}$		2	–	–		
MF Amplifier Gain	$G_{V(MF)}$	$I_L = 12$ to 80mA $f_{MF} = 1\text{kHz}$, $V_{MF} = 80\text{mV}$		15	–	17	dB	
DC Input Voltage Level (pin 14)	$V_I(MF)$	$V_{MF} = 80\text{mV}$		–	$0.3V_{DD}$	–	V	
Input Impedance (pin 14)	$Z_I(MF)$	$V_{MF} = 80\text{mV}$		40	–	–	k Ω	
Distortion	THD _{MF}	$V_{MF} = 110\text{mV}$, $I_L = 12$ to 80mA		–	–	2	%	

ELECTRICAL CHARACTERISTICS (TA = 25°C) (Continued)

Characteristic		Symbol	Test Conditions	Min.	Typ.	Max.	Unit
Starting Delay Time		$t_{D(ST)}$	$I_L = 12$ to 80mA	–	–	5	mS
Muting Threshold Voltage (pin 3)		$V_{TH(MUTE)}$		–	–	1	V
				1.6	–	–	
Muting Current	Standby	$I_{SB(MUTE)}$	$I_L = 12$ to 80mA	–	–	– 10	μA
	Operation	$I_{DD(MUTE)}$	$I_L = 12$ to 80mA	–	–	+ 10	

NOTES