

INTRODUCTION

The S1A2402C01 is a Controller for speed control, or a general-purpose low-voltage compact DC motor for micro-cassette tape recorders, radio cassettes and their equivalents.

FEATURES

- Operating supply voltage range:
 $V_{CC}=1.8V - 8V$
- Compact applicable set due to a minimum of external parts
- Easy speed adjustments
- Built-in stable low voltage reference:
 $V_{REF} = 0.2 V$

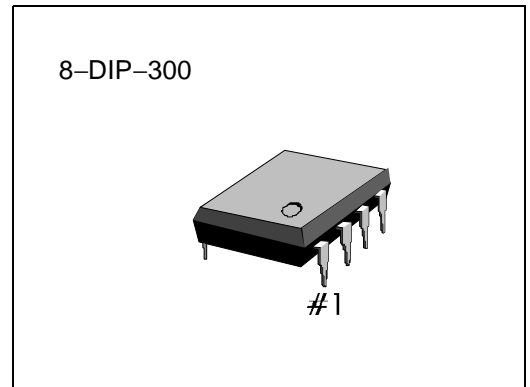

ORDERING INFORMATION

Device	Package	Operating Temperature
S1A2402C01-D0B0	8-DIP-300	-20°C - + 80°C

BLOCK DIAGRAM

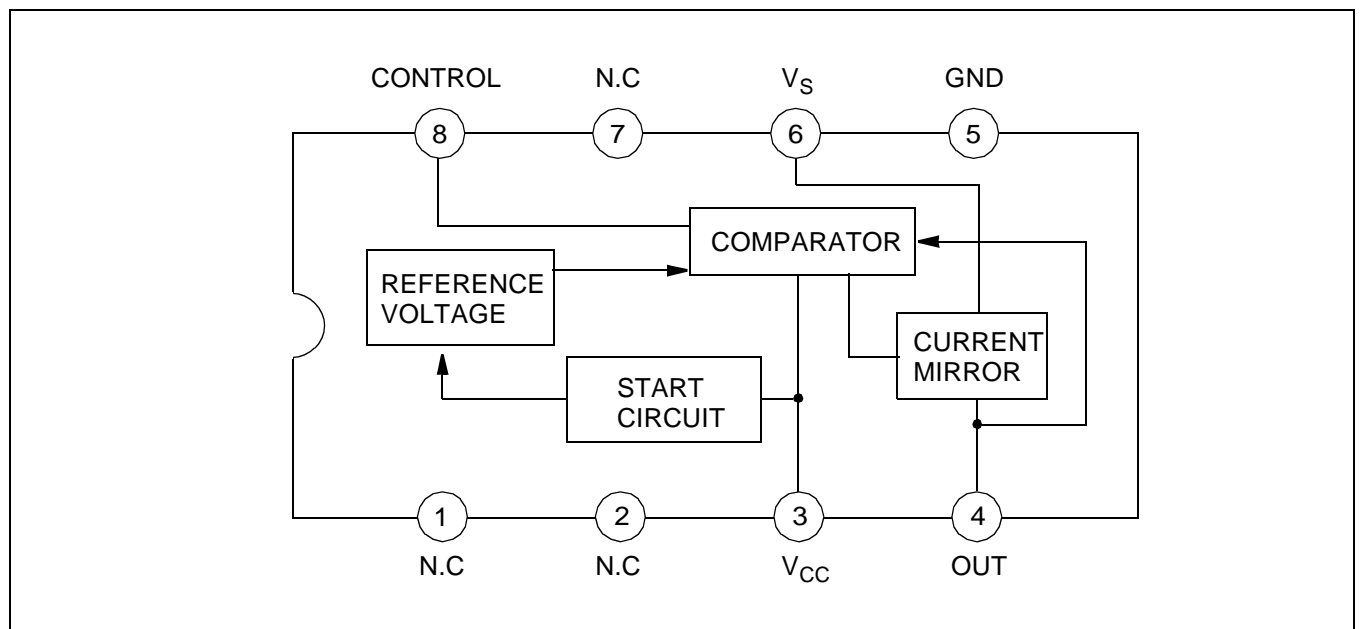

ABSOLUTE MAXIMUM RATINGS (Ta = 25°C)

Characteristic	Symbol	Value	Unit
Maximum Supply Voltage	V_{CC}	10	V
Maximum Motor Current	$I_{M(MAX)}$	700	mA
Power Dissipation	P_D	600	mW
Operating Temperature	T_{OPR}	-20 – + 80	°C
Storage Temperature	T_{STG}	-40 – + 125	°C

RECOMMENDED OPERATING CONDITIONS (Ta = 25°C)

Characteristic	Symbol	Value	Unit
Supply Voltage	V_{CC}	1.8 – 8	V
Recommended Operating Temperature	T_{OPR}	-20 – 60	°C

ELECTRICAL CHARACTERISTICS (Ta = 25°C)

Characteristic	Symbol	Test Conditions	Min.	Typ.	Max.	Unit
Reference Voltage	V_{REF}	$V_{CC} = 3V, I_M = 100mA$	0.18	0.2	0.22	V
Circuit Current	I_{CC}	$V_{CC} = 3V, I_M = 100mA$	–	2.4	6.0	mA
Current Coefficient	K	$V_{CC} = 3V, I_M = 50mA$ $I_M = 100mA$	45	50	55	–
Saturation Voltage	$V_{(SAT)}$	$V_{CC} = 3V, I_M = 100mA$	–	0.13	0.3	V
Voltage Characteristic of Reference Voltage	$\frac{\Delta V_{REF}}{V_{REF}} / \Delta V_{VCC}$	$I_M = 100mA,$ $V_{CC} = 1.8 – 8V (S1A2402C)$ $1.8 – 4.5V (S1A2402D)$	–	0.1	–	%/V
Voltage Characteristic of Current Coefficient	$\frac{\Delta K}{K} / \Delta V_{CC}$	$I_M = 50, 150mA$ $V_{CC} = 1.8 – 8V (S1A2402C)$ $1.8 – 4.5V (S1A2402D)$	–	0.3	–	%/V
Voltage Characteristic of Reference Voltage	$\frac{\Delta V_{REF}}{V_{REF}} / \Delta I_M$	$I_M = 3V$ $I_M = 20 – 200mA$	–	0.005	–	%/mA
Current Characteristic of Current Coefficient	$\frac{\Delta K}{K} / \Delta I_M$	$V_{CC} = 3V, I_M = 20, 50mA$ $– 170, 200mA$	–	-0.07	–	%/mA
Temperature Characteristic of Reference Voltage	$\frac{\Delta V_{REF}}{V_{REF}} / \Delta T_A$	$V_{CC} = 3V, I_M = 100mA$ $T_a = -20 – + 80°C$	–	-0.008	–	%/°C
Temperature Characteristic of Current Coefficient	$\frac{\Delta K}{K} / \Delta T_A$	$V_{CC} = 3V, I_M = 50 m, 150mA$ $T_a = -20 – + 80°C$	–	0.02	–	%/°C

TEST CIRCUIT

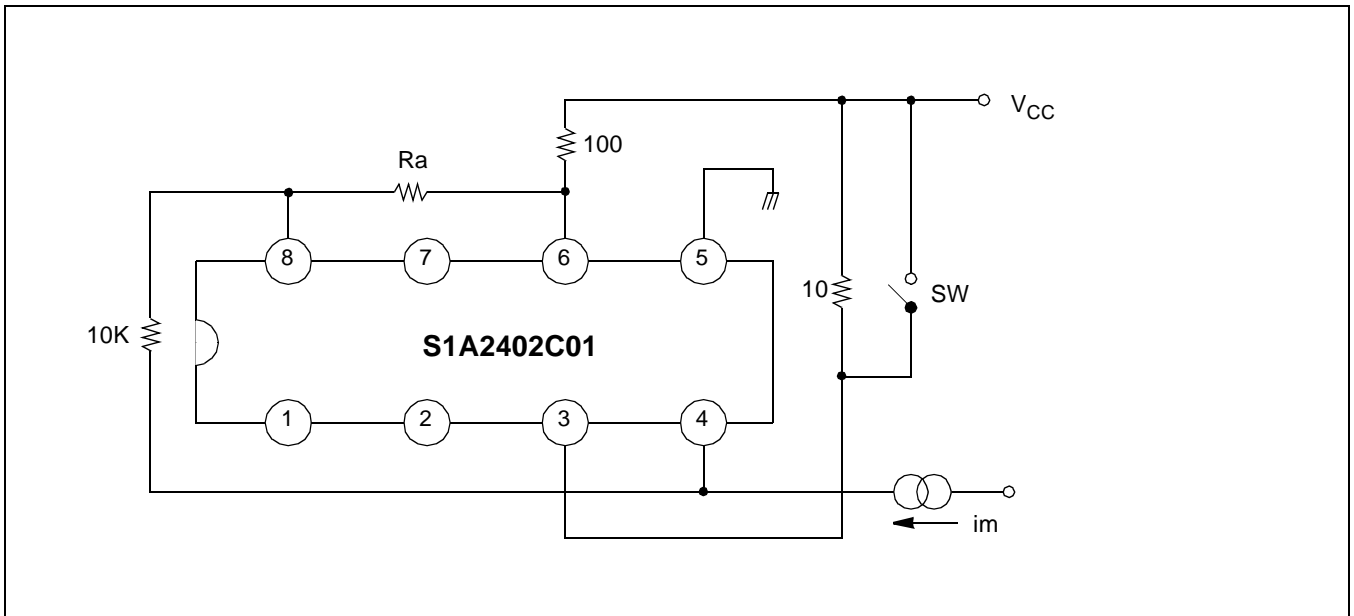

APPLICATION CIRCUIT

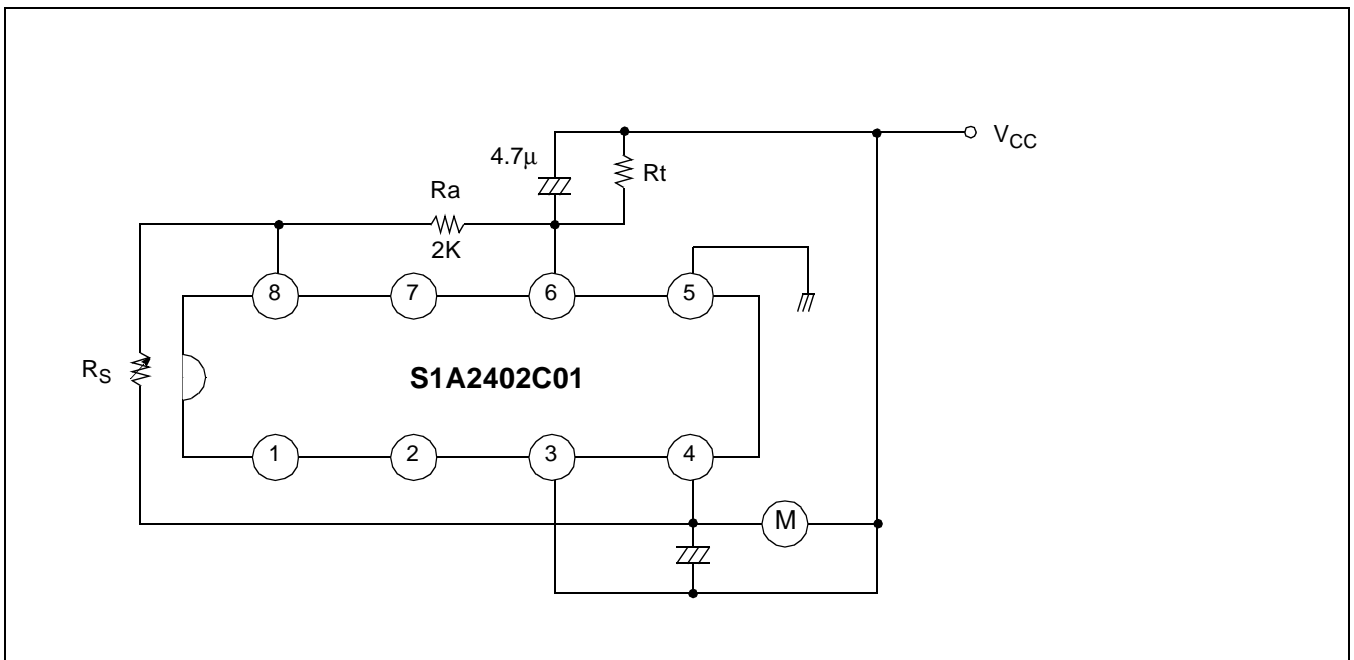

NOTES