

**INTRODUCTION**

The S1A0136A01 is a monolithic intergrated circuit designed for use in low voltage and low power applications. It has functions including dual audio pre-power amplifier, electronic volume controller and DC motor speed controller in a single chip. It is suitable for portable tape recorders headphone cassette tape recorders or radios that are battery-operated.

**FEATURES**

- Low current consumption in an operating voltage range
- Operating supply voltage range:  $V_{cc} = 2.1V - 5V$
- Only a few components in composing a headphone cassette tape recorder
- Dual audio pre-power amplifier, electronic volume controller and DC motor speed controller in a single chip
- Reduced input and output coupling capacitors because of 1/2  $V_{cc}$  AMP adoption on chip as AC GND

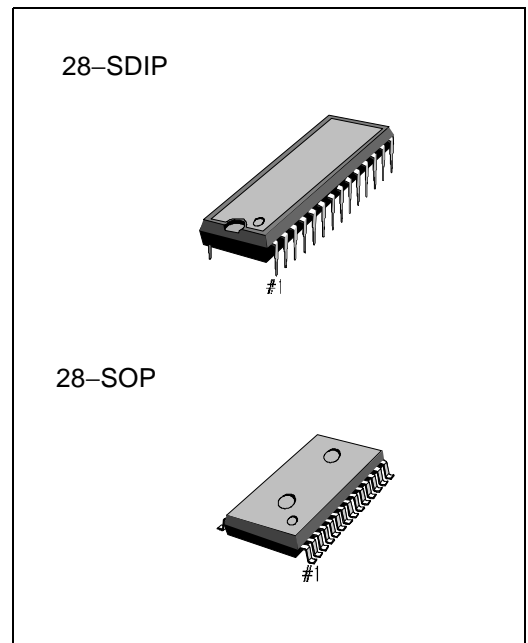

**ORDERING INFORMATION**

Device	Package	Operating Temperature
S1A0136A01-A0B0	28-SDIP	-20°C — + 65°C
S1A0136A01-S0B0	28-SOP	

**BLOCK DIAGRAM**

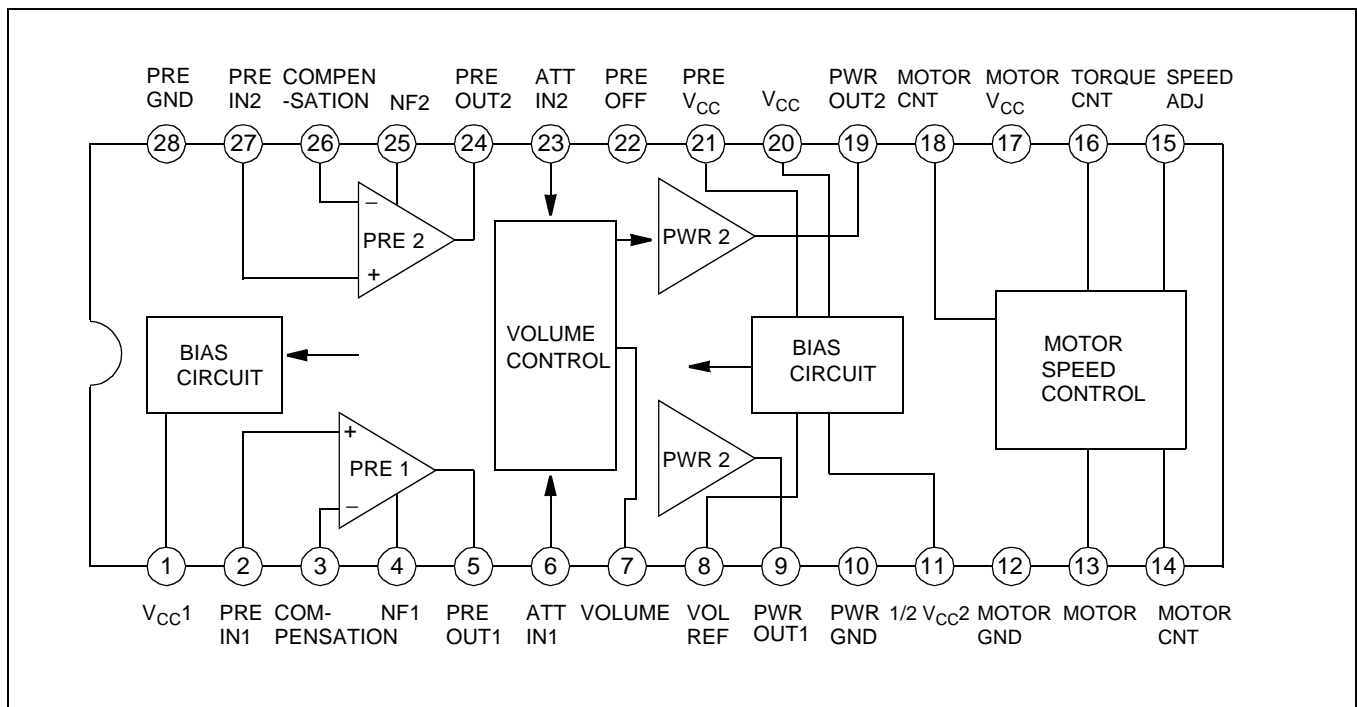

**ABSOLUTE MAXIMUM RATINGS (Ta = 25°C)**

Characteristic	Symbol	Value	Unit
Supply Voltage	V <sub>CC</sub>	7.5	V
Power Dissipation	P <sub>O</sub>	450	mW
Operating Temperature	T <sub>OPR</sub>	-20 — +70	°C
Storage Temperature	T <sub>STG</sub>	-40 — +125	°C

**ELECTRICAL CHARACTERISTICS**(Ta = 25°C, V<sub>CC</sub> = 3V, unless otherwise specified)

Characteristic	Symbol	Test Conditions	Min.	Typ.	Max.	Unit
Quiescent Circuit Current	I <sub>CCQ</sub>	V <sub>CC</sub> = 3V, V <sub>I</sub> = 0, I <sub>M</sub> = 0	–	18	25	mA

**PRE AMPLIFIER SECTION**(V<sub>CC</sub> = 3V, f = 1kHz, R<sub>L1</sub> = 10kΩ, unless otherwise specified)

Characteristic	Symbol	Test Conditions	Min.	Typ.	Max.	Unit
Open Loop Voltage Gain	G <sub>VO</sub>	V <sub>O</sub> = -10dBm, R <sub>L</sub> = ∞	–	70	–	dB
Closed Loop Voltage Gain	G <sub>VC1</sub>	V <sub>O</sub> = -10dBm	40	42	44	dB
Output Voltage	V <sub>O</sub>	THD = 1%	0.45	0.6	–	V
Total Harmonic Distortion	THD	V <sub>O</sub> = 0.2V	–	0.05	0.5	%
Output Noise Voltage	V <sub>NO1</sub>	V <sub>i</sub> = 0, R <sub>g</sub> = 2.2kΩ, BPF(30 – 20kHz)	–	150	300	μV
Input Resistance	R <sub>I</sub>	V <sub>O</sub> = 10dBm	18	22	–	kΩ
Cross Talk	CT <sub>1</sub>	R <sub>G</sub> = 2.2kΩ, V <sub>O</sub> = -10dBm	30	–	–	dB
Output Voltage In Pre OFF	V <sub>O(OFF)</sub>	V <sub>I</sub> = 100mV Pre OFF (pin 22) = V <sub>CC</sub>	–	–	-50	dB

**POWER AMPLIFIER SECTION**(Ta = 25°C, V<sub>CC</sub> = 3V, unless otherwise specified)

Characteristic	Symbol	Test Conditions	Min.	Typ.	Max.	Unit
Closed Loop Voltage Gain	G <sub>VC2</sub>	P <sub>O</sub> = 5mW	26	28	30	dB
Voltage Gain Difference	ΔG <sub>V</sub>	V <sub>CONT</sub> = Max	–	0	3	dB
Output Power 1	P <sub>O1</sub>	THD = 10%, R <sub>L</sub> = 32Ω	20	28	–	mW
Output Power 2	P <sub>O2</sub>	THD = 10%, R <sub>L</sub> = 16Ω	30	–	–	mW
Total Harmonic Distortion	THD <sub>2</sub>	P <sub>O</sub> = 5mW	–	0.2	2.0	%
Pre+ Power Output Noise Voltage	V <sub>NO2I</sub>	V <sub>I</sub> = 0, R <sub>G</sub> = 2.2kΩ, V <sub>CONT</sub> = Max	–	6	10	mV
Output Noise Voltage	V <sub>NO3I</sub>	R <sub>G</sub> = 2.2 kΩ, V <sub>CONT</sub> = Min	–	0.25	1.0	mV
Cross Talk	CT <sub>2</sub>	R <sub>O</sub> = 5mW	20	30	–	dB
Ripple Rejection Ratio	RR	V <sub>CC</sub> = 3V, 100Hz, 100mVp-p	34	40	–	dB

## ATTENUATOR SECTION

( $T_a = 25^\circ\text{C}$ ,  $V_{CC} = 3\text{V}$ ,  $f = 1\text{kHz}$ , unless otherwise specified)

Characteristic	Symbol	Test Conditions	Min.	Typ.	Max.	Unit
Maximum Input Voltage	$V_{I(\text{MAX})}$	–	0.2	–	–	V
Maximum Attenuation	$V_{\text{ATT}(\text{MAX})}$	$V_{\text{CONT}} = \text{Min}$	66	–	–	dB
Attenuation Error	$V_{\text{ATT}(\text{ERR})}$	$V_{\text{CONT}} = \text{Max}$	–	0	–	dB
Input Impedance	$Z_I$	–	15	20	–	$\text{K}\Omega$

## MOTOR SPEED CONTROLLER

( $T_a = 25^\circ\text{C}$ ,  $V_{CC} = 3\text{V}$ ,  $I_M = 100\text{mA}$ , unless otherwise specified)

Characteristic	Symbol	Test Conditions	Min.	Typ.	Max.	Unit
Circuit Current	$I_{MC}$	–	–	3.0	5.0	mA
Starting Current	$I_{MS}$	–	500	–	–	mA
Reference Voltage	$V_{\text{REF}}$	V(pin 15, 16)	0.72	0.80	0.87	V
Reference Voltage Regulation 1	$\Delta V_{\text{REF}1}$	$V_{CC} = 2.1 - 5.0\text{V}$	–	0.05	–	%/V
Reference Voltage Regulation 2	$\Delta V_{\text{REF}2}$	$I_M = 25 - 250\text{mA}$	–	0.01	–	%/mA
Reference Voltage Regulation 3	$\Delta V_{\text{REF}3}$	$T_a = -10 \sim 50^\circ\text{C}$	–	0.01	–	%/°C
Current Coefficient	K	–	32	38	43	–
Current Coefficient Regulation 1	$\Delta K1$	$V_{CC} = 2.1 - 5.0\text{V}$	–	0.50	–	%/V
Current Coefficient Regulation 2	$\Delta K2$	$I_M = 25 - 250\text{mA}$	–	0.05	–	%/mA
Current Coefficient Regulation 3	$\Delta K3$	$T_a = -10 - 50^\circ\text{C}$	–	0.02	–	%/°C
Saturation Voltage	$V_{\text{SAT}}$	$I_M = 200\text{mA}$ , Pin14 = $V_{CC}$	–	–	0.6	V
Leakage Current	$I_{\text{LKG}}$	Pin 18 = $V_{CC}$	–	50	200	$\mu\text{V}$

\* Voltage across Pin 13, 17

TEST CIRCUIT

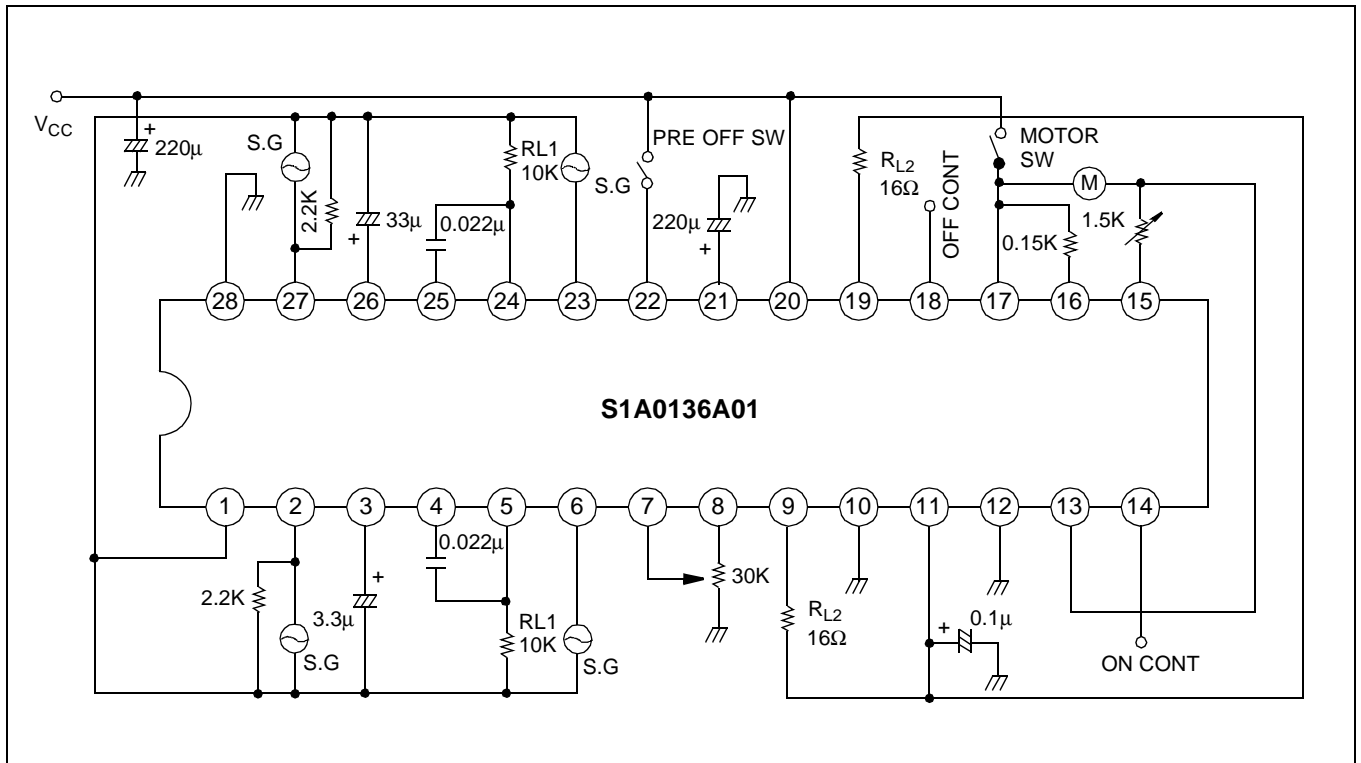

APPLICATION CIRCUIT

