

## 32M-Bit (4Mx8 /2Mx16) CMOS MASK ROM

### FEATURES

- Switchable organization  
4,194,304x8(byte mode)  
2,097,152x16(word mode)
- Fast access time  
3.3V Operation : 100ns(Max.)@CL=50pF,  
120ns(Max.)@CL=100pF  
3.0V Operation : 120ns(Max.)@CL=100pF
- Supply voltage : single +3.0V/ single +3.3V
- Current consumption  
Operating : 40mA(Max.)  
Standby : 30μA(Max.)
- Fully static operation
- All inputs and outputs TTL compatible
- Three state outputs
- Package  
-. K3N6V(U)1000E-GC : 44-SOP-600

### GENERAL DESCRIPTION

The K3N6V(U)1000E-GC is a fully static mask programmable ROM fabricated using silicon gate CMOS process technology, and is organized either as 4,194,304 x 8 bit(byte mode) or as 2,097,152 x 16 bit(word mode) depending on BHE voltage level.(See mode selection table)

This device operates with 3.0V or 3.3V power supply, and all inputs and outputs are TTL compatible.

Because of its asynchronous operation, it requires no external clock assuring extremely easy operation.

It is suitable for use in program memory of microprocessor, and data memory, character generator.

The K3N6V(U)1000E-GC is packaged in a 44-SOP.

### FUNCTIONAL BLOCK DIAGRAM

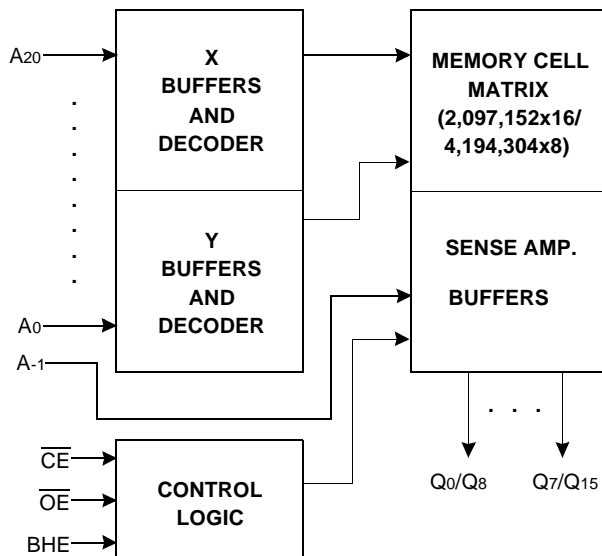

Pin Name	Pin Function
A <sub>0</sub> - A <sub>20</sub>	Address Inputs
Q <sub>0</sub> - Q <sub>14</sub>	Data Outputs
Q <sub>15</sub> /A <sub>-1</sub>	Output 15(Word mode)/ LSB Address(Byte mode)
BHE	Word/Byte selection
$\overline{\text{CE}}$	Chip Enable
$\overline{\text{OE}}$	Output Enable
V <sub>cc</sub>	Power
V <sub>ss</sub>	Ground
N.C	No Connection

### PIN CONFIGURATION

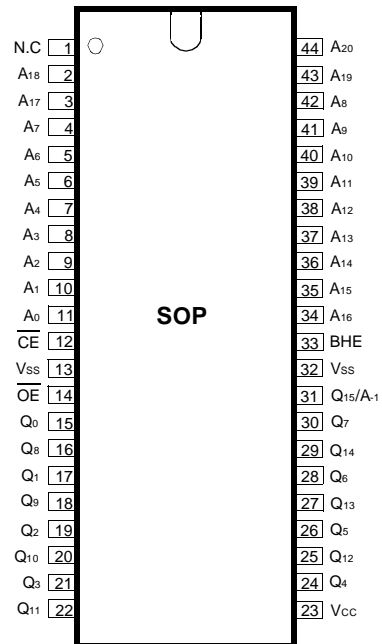

K3N6V(U)1000E-GC

## ABSOLUTE MAXIMUM RATINGS

Item	Symbol	Rating	Unit
Voltage on Any Pin Relative to V <sub>SS</sub>	V <sub>IN</sub>	-0.3 to +4.5	V
Temperature Under Bias	T <sub>BIAS</sub>	-10 to +85	°C
Storage Temperature	T <sub>Stg</sub>	-55 to +150	°C

**NOTE :** Permanent device damage may occur if "ABSOLUTE MAXIMUM RATINGS" are exceeded. Functional operation should be restricted to the conditions as detailed in the operational sections of this data sheet. Exposure to absolute maximum rating conditions for extended periods may affect device reliability.

RECOMMENDED OPERATING CONDITIONS(Voltage reference to V<sub>SS</sub>, T<sub>A</sub>=0 to 70°C)

Item	Symbol	Min	Typ	Max	Unit
Supply Voltage	V <sub>CC</sub>	2.7/3.0	3.0/3.3	3.3/3.6	V
Supply Voltage	V <sub>SS</sub>	0	0	0	V

## DC CHARACTERISTICS

Parameter	Symbol	Test Conditions	Min	Max	Unit	
Operating Current	I <sub>CC</sub>	Cycle=5MHz, all outputs open, $\overline{CE}=\overline{OE}=V_{IL}$ , V <sub>IN</sub> =0.45V to 2.4V (AC Test Condition)	V <sub>CC</sub> =3.3V±0.3V	-	40	mA
			V <sub>CC</sub> =3.0V±0.3V		35	mA
Standby Current(TTL)	I <sub>SB1</sub>	$\overline{CE}=V_{IH}$ , all outputs open		500	μA	
Standby Current(CMOS)	I <sub>SB2</sub>	$\overline{CE}=V_{CC}$ , all outputs open		30	μA	
Input Leakage Current	I <sub>LI</sub>	V <sub>IN</sub> =0 to V <sub>CC</sub>	-	10	μA	
Output Leakage Current	I <sub>LO</sub>	V <sub>OUT</sub> =0 to V <sub>CC</sub>	-	10	μA	
Input High Voltage, All Inputs	V <sub>IH</sub>		2.0	V <sub>CC</sub> +0.3	V	
Input Low Voltage, All Inputs	V <sub>IL</sub>		-0.3	0.6	V	
Output High Voltage Level	V <sub>OH</sub>	I <sub>OH</sub> =-400μA	2.4	-	V	
Output Low Voltage Level	V <sub>OL</sub>	I <sub>OL</sub> =2.1mA	-	0.4	V	

**NOTE :** Minimum DC Voltage(V<sub>IL</sub>) is -0.3V on input pins. During transitions, this level may undershoot to -2.0V for periods <20ns.  
Maximum DC voltage on input pins(V<sub>IH</sub>) is V<sub>CC</sub>+0.3V which, during transitions, may overshoot to V<sub>CC</sub>+2.0V for periods <20ns.

## MODE SELECTION

CE	OE	BHE	Q15/A-1	Mode	Data	Power
H	X	X	X	Standby	High-Z	Standby
L	H	X	X	Operating	High-Z	Active
L	L	H	Output	Operating	Q <sub>0</sub> -Q <sub>15</sub> : Dout	Active
		L	Input	Operating	Q <sub>0</sub> -Q <sub>7</sub> : Dout Q <sub>8</sub> -Q <sub>14</sub> : Hi-Z	Active

CAPACITANCE(T<sub>A</sub>=25°C, f=1.0MHz)

Item	Symbol	Test Conditions	Min	Max	Unit
Output Capacitance	C <sub>OUT</sub>	V <sub>OUT</sub> =0V	-	12	pF
Input Capacitance	C <sub>IN</sub>	V <sub>IN</sub> =0V	-	12	pF

**NOTE :** Capacitance is periodically sampled and not 100% tested.

## AC CHARACTERISTICS (TA=0°C to +70°C, VCC=3.3V/3.0V±0.3V, unless otherwise noted.)

### TEST CONDITIONS

Item	Value
Input Pulse Levels	0.45V to 2.4V
Input Rise and Fall Times	10ns
Input and Output timing Levels	1.5V
Output Loads	1 TTL Gate and CL=50pF or 100pF

### READ CYCLE

Item	Symbol	K3N6V1000E-GC10 (CL=50pF)		K3N6V1000E-GC12 (CL=100pF)		K3N6U1000E-GC12 (CL=100pF)		Unit
		Min	Max	Min	Max	Min	Max	
Read Cycle Time	tRC	100		120		120		ns
Chip Enable Access Time	tACE		100		120		120	ns
Address Access Time	tAA		100		120		120	ns
Output Enable Access Time	tOE		50		60		60	ns
Output or Chip Disable to Output High-Z	tDF		20		20		20	ns
Output Hold from Address Change	tOH	0		0		0		ns

### TIMING DIAGRAM

#### READ

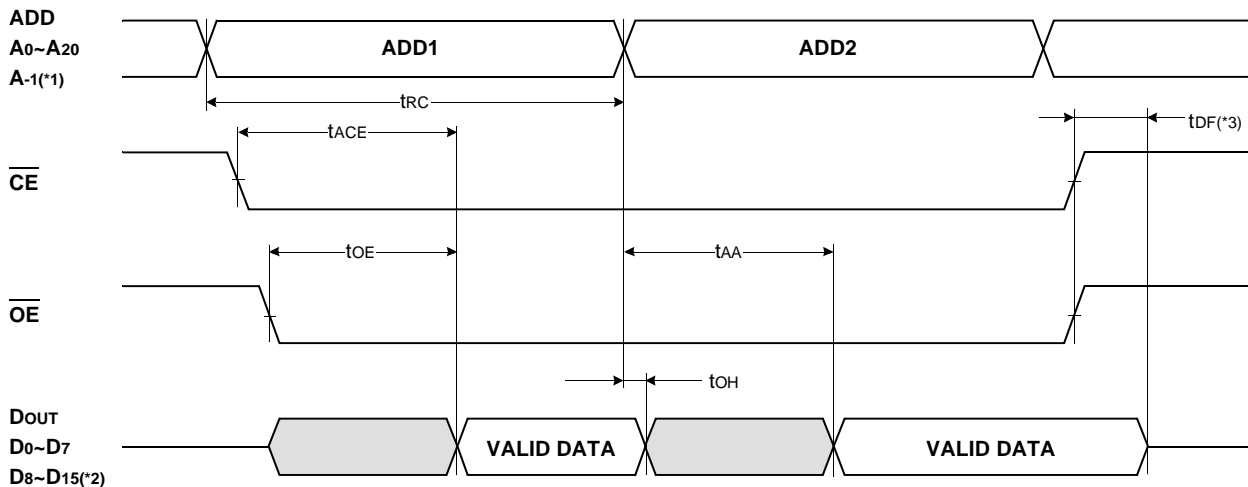

#### NOTES :

\*1. Byte Mode only. A-1 is Least Significant Bit Address. (BHE = VIL)

\*2. Word Mode only. (BHE = VIH)

\*3. tDF is defined as the time at which the outputs achieve the open circuit condition and is not referenced to VOH or VOL level.