



6 CHANNELS VOLUME CONTROLLER

GENERAL DESCRIPTION

The SM7347A is 6 channels electronic volume controlled by 3-wire serial data. The IC is suitable for use in DVD systems and AV.

APPLICATIONS

- \* DVD Receivers
- \* Home Audio equipment
- \* AV

FEATURES

- \* Built-in microcomputer interface circuit controlled by 16-bit serial data.
- \* Electronic volume  
Volume level.....0dB~95dB, -∞dB(1dB/step)

PIN ASSIGNMENTS

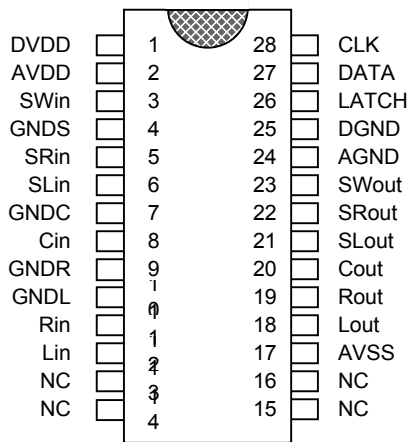

SOP 28PIN

BLOCK DIAGRAM

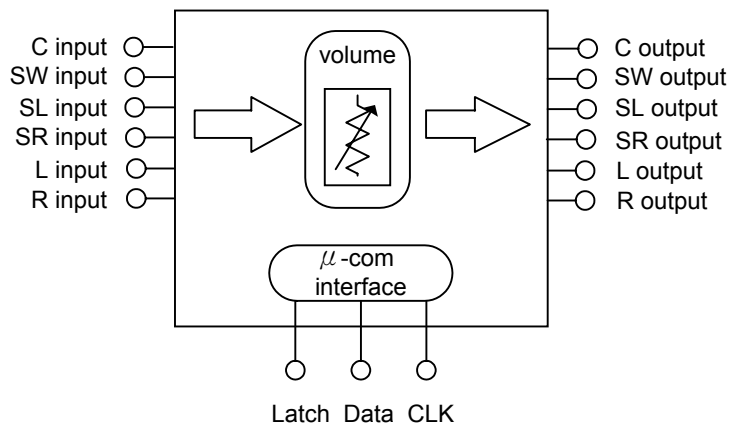



**6 CHANNELS VOLUME CONTROLLER**

**PIN DESCRIPTION**

Pin No.	Symbol	Function	Circuit
1	DVDD	Digital Power supply	+5V
2	AVDD	Analog positive Power supply	+7V
3	SWin	Volume INPUT	
5	SRin		
6	SLin		
8	Cin		
11	Rin		
12	Lin		
23	SWout	Volume OUTPUT	
22	SRout		
21	SLout		
20	Cout		
19	Rout		
18	Lout		
17	AVSS	Analog negative Power supply	-7V
24	AGND	Analog GND	<p>INPUT:schmitt trigger type</p>
25	DGND	Digital GND	
26	LATCH	Latch INPUT	
27	DATA	Data INPUT	
28	CLK	Clock INPUT Forward data	
4	GNDS	GND	Connect to analog GND
7	GNDC		
9	GNDR		
10	GNDL		



**6 CHANNELS VOLUME CONTROLLER**

**PIN CONFIGURATION AND IC INTERNAL BLOCK DIAGRAM**

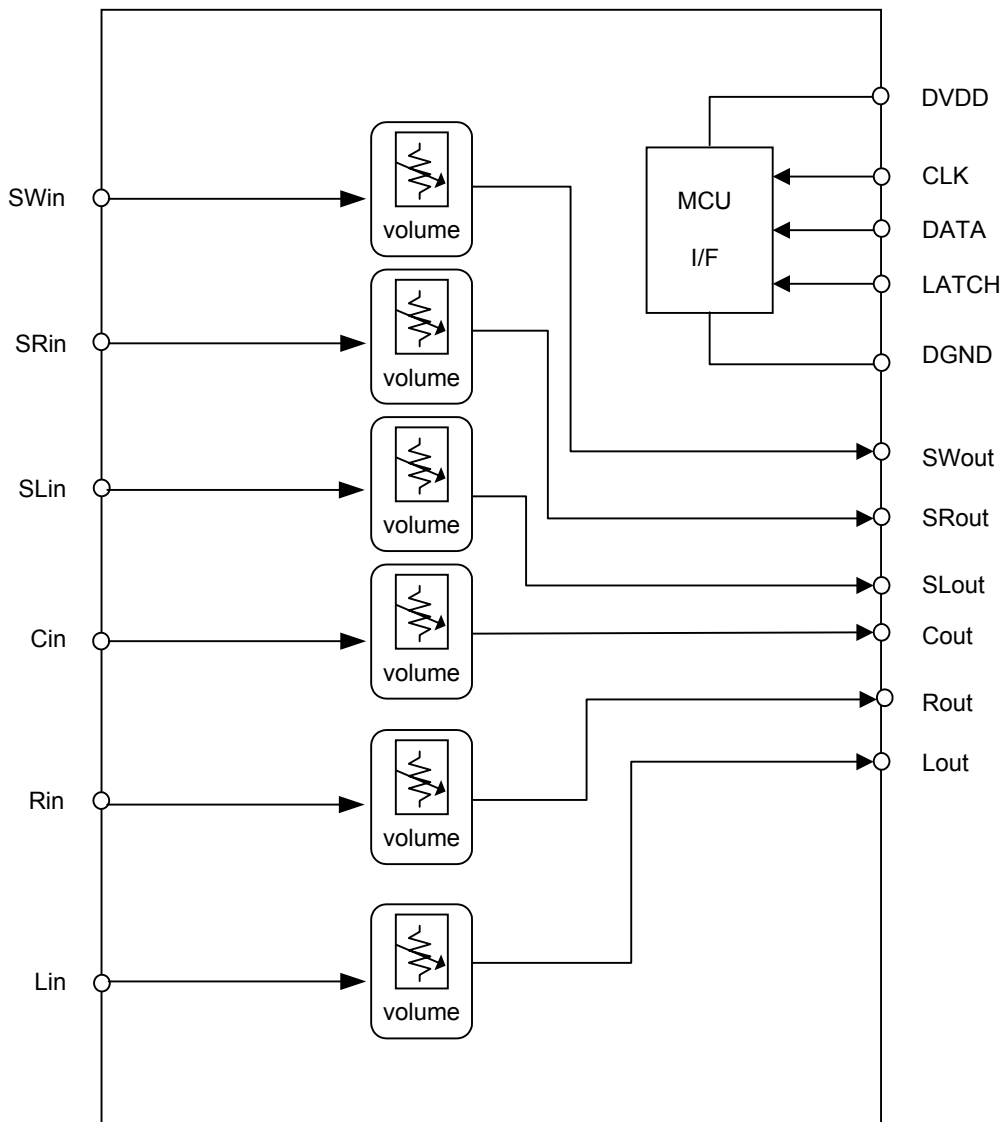



6 CHANNELS VOLUME CONTROLLER

ABSOLUTE MAXIMUM RATINGS

Symbol	Parameter	Conditions	Ratings	Unit
Vsupply	Supply Voltage	AVDD-AVSS	16.0	V
Pd	Power dissipation	Ta≤25°C	1000	mW
K <sub>θ</sub>	Thermal derating	Ta>25°C *standard board	10	mW / °C
Topr	Operating temperature		-20~+75	°C
Tstg	Storage temperature		-40~+125	°C

THERMAL DERATING (MAXIMUM RATING)  
Standard board

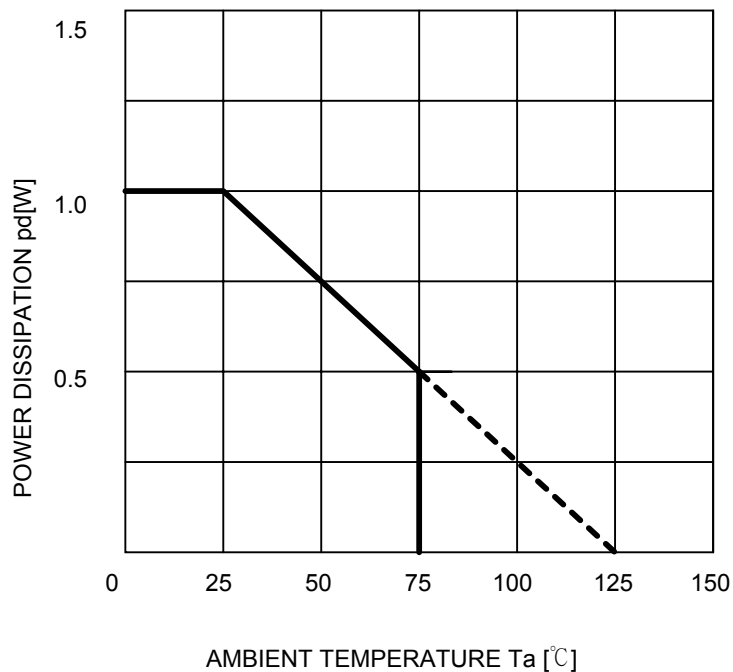



6 CHANNELS VOLUME CONTROLLER

RECOMMENDED OPERATING CONDITION

Parameter	Symbol	Condition	Min.	Typ.	Max.	Unit
Analog positive Supply Voltage	AVDD		6.0	7.0	8.0	V
Analog negative Supply Voltage	AVSS		- 8.0	- 7.0	- 6.0	V
Digital Supply Voltage	DVDD		4.5	5.0	5.5	V
High-level Input Voltage	VIH		DVDDX0.7	—	DVDD	V
Low-level Input Voltage	VIL		DGND	—	DVDDX0.3	V

Note1 :  $AVSS \leq DGND < DVDD \leq AVDD$  or  $AVSS \leq DGND < AVDD \leq DVDD$

Note2 :  $AGND = (AVSS + AVDD) / 2$

DATA TIMING(Recommended conditions)

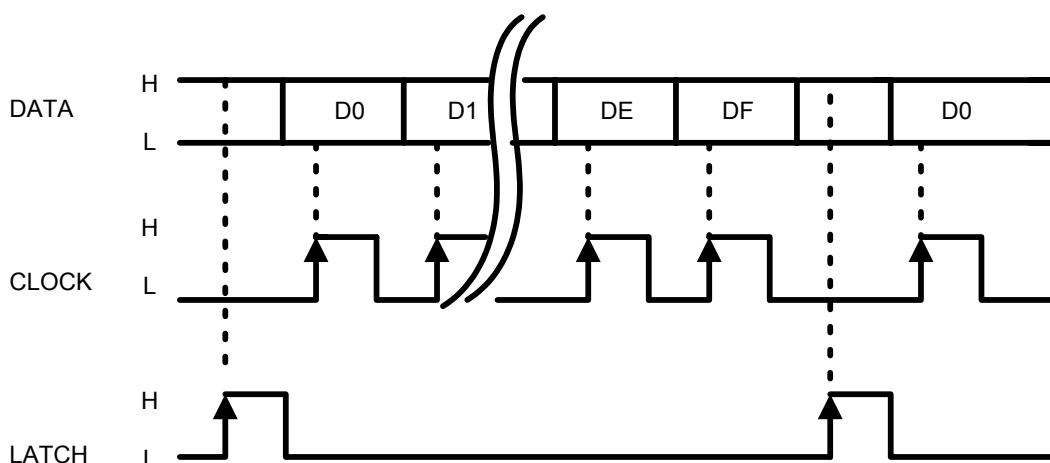

Note: CLOCK and LATCH function at raising edges of pulse.



6 CHANNELS VOLUME CONTROLLER

CLOCK, DATA, LATCH TIMING

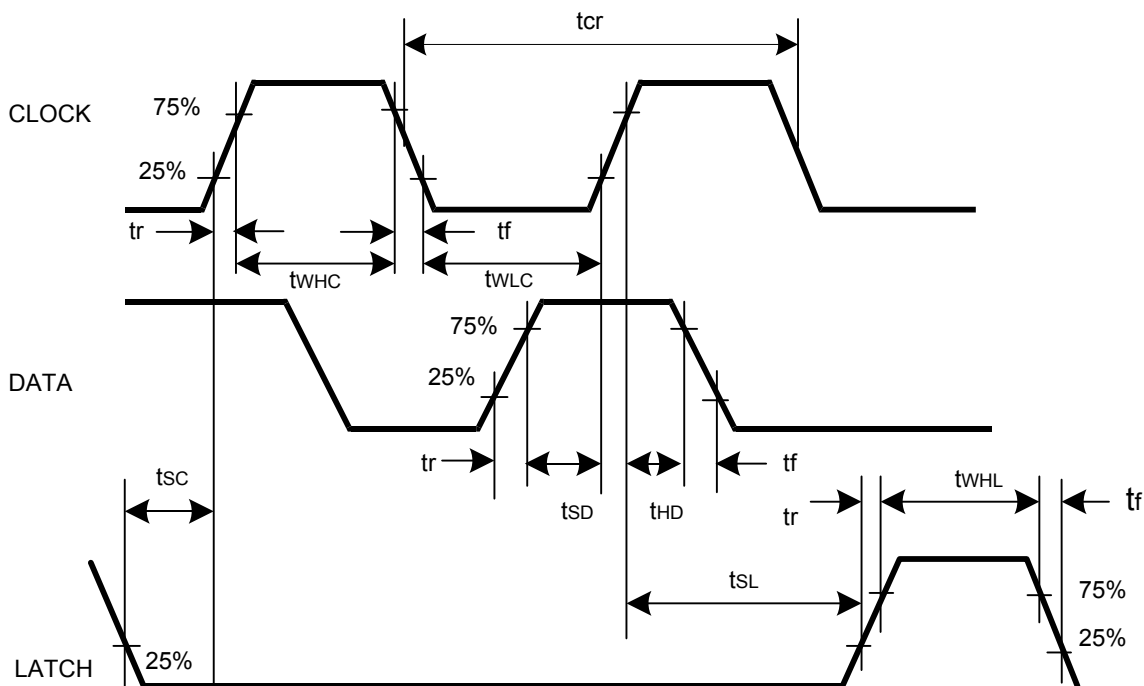

DIGITAL BLOCK TIMING REGULATION

Symbol	Parameter	Limits			Unit
		Min	Typ	Max	
$t_{cr}$	CLOCK cycle time	8	—	—	$\mu$ sec
$t_{wHC}$	CLOCK pulse width("H"level)	3.2	—	—	
$t_{wLC}$	CLOCK pulse width("L"level)	3.2	—	—	
$t_r$	CLOCK,DATA,LATCH rise time	—	—	0.8	
$t_f$	CLOCK,DATA,LATCH fall time	—	—	0.8	
$t_{SD}$	DATA setup time	1.6	—	—	
$t_{HD}$	DATA hold time	1.6	—	—	
$t_{SL}$	LATCH setup time	2	—	—	
$t_{wHL}$	LATCH pulse width	3.2	—	—	
$t_{sc}$	CLOCK start time after LATCH	3.2	—	—	



**6 CHANNELS VOLUME CONTROLLER**

**DIGITAL CONTROL SPECIFICATION**

Four kinds of input format options are available by changing slot settings of DE and DF.

( 1 )

D01	D11	D21	D31	D41	D51	D61	D71	D81	D91	DA1	DB1	DC1	DD1	DE	DF
0	0	0	0	0	0	0	0	0	0	0	0	0	1	0	0

( 2 )

D02	D12	D22	D32	D42	D52	D62	D72	D82	D92	DA2	DB2	DC2	DD2	DE	DF
VOLUME Lch							VOLUME Rch							0	1

( 3 )

D03	D32	D23	D33	D43	D53	D63	D73	D83	D93	DA3	DB3	DC3	DD3	DE	DF
VOLUME Cch							VOLUME SWch							1	0

( 4 )

D04	D14	D24	D34	D44	D54	D64	D74	D84	D94	DA4	DB4	DC4	DD4	DE	DF
VOLUME SLch							VOLUME SRch							1	1

Note:When the IC is powered up, the internal setting of channel output are fixed to - ∞.



**6 CHANNELS VOLUME CONTROLLER**

(2)-1 Volume ( 0~-39dB )

Note: Do not input other data than the above.

A T T	Volume		D0X	D1X	D2X	D3X	D4X	D5X	D6X
			D7X	D8X	D9X	DAX	DBX	DCX	DDX
-	0	dB	0	0	0	0	0	0	0
-	1	dB	0	0	0	0	0	0	1
-	2	dB	0	0	0	0	0	1	0
-	3	dB	0	0	0	0	0	1	1
-	4	dB	0	0	0	0	1	0	0
-	5	dB	0	0	0	0	1	0	1
-	6	dB	0	0	0	0	1	1	0
-	7	dB	0	0	0	0	1	1	1
-	8	dB	0	0	0	1	0	0	0
-	9	dB	0	0	0	1	0	0	1
-	10	dB	0	0	0	1	0	1	0
-	11	dB	0	0	0	1	0	1	1
-	12	dB	0	0	0	1	1	0	0
-	13	dB	0	0	0	1	1	0	1
-	14	dB	0	0	0	1	1	1	0
-	15	dB	0	0	0	1	1	1	1
-	16	dB	0	0	1	0	0	0	0
-	17	dB	0	0	1	0	0	0	1
-	18	dB	0	0	1	0	0	1	0
-	19	dB	0	0	1	0	0	1	1
-	20	dB	0	0	1	0	1	0	0
-	21	dB	0	0	1	0	1	0	1
-	22	dB	0	0	1	0	1	1	0
-	23	dB	0	0	1	0	1	1	1
-	24	dB	0	0	1	1	0	0	0
-	25	dB	0	0	1	1	0	0	1
-	26	dB	0	0	1	1	0	1	0
-	27	dB	0	0	1	1	0	1	1
-	28	dB	0	0	1	1	1	0	0
-	29	dB	0	0	1	1	1	0	1
-	30	dB	0	0	1	1	1	1	0
-	31	dB	0	0	1	1	1	1	1
-	32	dB	0	1	0	0	0	0	0
-	33	dB	0	1	0	0	0	0	1
-	34	dB	0	1	0	0	0	1	0
-	35	dB	0	1	0	0	0	1	1
-	36	dB	0	1	0	0	1	0	0
-	37	dB	0	1	0	0	1	0	1
-	38	dB	0	1	0	0	1	1	0
-	39	dB	0	1	0	0	1	1	1





6 CHANNELS VOLUME CONTROLLER

(2)-2 VOLUME ( -40 ~ - ∞ dB )

Note: Do not input other data than the above.

A T T	Volume	D0X	D1X	D2X	D3X	D4X	D5X	D6X
		D7X	D8X	D9X	DAX	DBX	DCX	DDX
-	40 dB	0	1	0	1	0	0	0
-	41 dB	0	1	0	1	0	0	1
-	42 dB	0	1	0	1	0	1	0
-	43 dB	0	1	0	1	0	1	1
-	44 dB	0	1	0	1	1	0	0
-	45 dB	0	1	0	1	1	0	1
-	46 dB	0	1	0	1	1	1	0
-	47 dB	0	1	0	1	1	1	1
-	48 dB	0	1	1	0	0	0	0
-	49 dB	0	1	1	0	0	0	1
-	50 dB	0	1	1	0	0	1	0
-	51 dB	0	1	1	0	0	1	1
-	52 dB	0	1	1	0	1	0	0
-	53 dB	0	1	1	0	1	0	1
-	54 dB	0	1	1	0	1	1	0
-	55 dB	0	1	1	0	1	1	1
-	56 dB	0	1	1	1	0	0	0
-	57 dB	0	1	1	1	0	0	1
-	58 dB	0	1	1	1	0	1	0
-	59 dB	0	1	1	1	0	1	1
-	60 dB	0	1	1	1	1	0	0
-	61 dB	0	1	1	1	1	0	1
-	62 dB	0	1	1	1	1	1	0
-	63 dB	0	1	1	1	1	1	1
-	64 dB	1	0	0	0	0	0	0
-	65 dB	1	0	0	0	0	0	1
-	66 dB	1	0	0	0	0	1	0
-	67 dB	1	0	0	0	0	1	1
-	68 dB	1	0	0	0	1	0	0
-	69 dB	1	0	0	0	1	0	1
-	70 dB	1	0	0	0	1	1	0
-	71 dB	1	0	0	0	1	1	1
-	72 dB	1	0	0	1	0	0	0
-	73 dB	1	0	0	1	0	0	1
-	74 dB	1	0	0	1	0	1	0
-	75 dB	1	0	0	1	0	1	1
-	76 dB	1	0	0	1	1	0	0
-	77 dB	1	0	0	1	1	0	1
-	78 dB	1	0	0	1	1	1	0
-	79 dB	1	0	0	1	1	1	1
-	∞ dB	1	0	1	0	0	0	0



**6 CHANNELS VOLUME CONTROLLER****ELECTRICAL CHARACTERISTICS**

( Ta=25°C, AVDD=7.0V, AVSS=-7.0V, DVDD=5.0V, f=1kHz, unless otherwise noted. Rg=1KΩ, RI=10KΩ, VOLUME are set to 0dB/FLAT )

**(1)Power Supply Characteristics**

Parameter	Symbol	Test condition	Limits			Unit
			Min	typ	Max	
Analog positive circuit current	Aldd	Current at pin 2 No signal input	–	24	35	mA
Analog negative circuit current	Alss	Current at pin 17 No signal input	–	24	35	mA
Digital circuit current	Didd	Current at pin 1 No signal input	–	1.0	2.0	mA

**(2)Input/Output Characteristics**

Parameter	Symbol	Test condition	Limits			Unit
			Min	typ	Max	
Input resistance	Rin	3,5,6,8,11,12pin	35	70	150	KΩ
Maximum output voltage	VOM	3,5,6,8,11,12pin INPUT 18~23pin OUTPUT, THD=1%	3.0	4.2	–	Vrms
Pass gain	Gv	Vi=0.2Vrms,FLAT 3,5,6,8,11,12pin INPUT 18~23pin OUTPUT	-2.0	0	2.0	dB
Distortion	THD	BW=400~30kHz Vi=0.2Vrms,RL=10KΩ	–	0.004	0.09	%
Output noise voltage	Vn(VOL)	18~23pin JIS-A, VOL=0dB	–	4	6	μVrms
Signal to noise ratio	S/N	all gains=0dB; Vo=1Vrms	–	98	105	dB
Maximum attenuation	ATTmax	18~23 pin JIS-A, VOL=-∞dB	–	-100	-95	dB
Volume gain between channels	Dvol		-1.5	0	1.5	dB
Crosstalk between channels	CT	Vo=0.5Vrms,RL=10KΩ, JIS-A, Rg=1KΩ	–	-100	-75	dB
Port output current	IL	RL=22KΩ	0.2	–	–	mA



6 CHANNELS VOLUME CONTROLLER

RECOMMENDED OPERATING CONDITIONS

	Analog	Digital
Supply voltage range	$\pm 6.0 \sim \pm 8.0V$	4.5 ~ 5.5V
Rated supply voltage	$\pm 7.0V$	5.0V

SIGNAL PROCESSING DIAGRAM

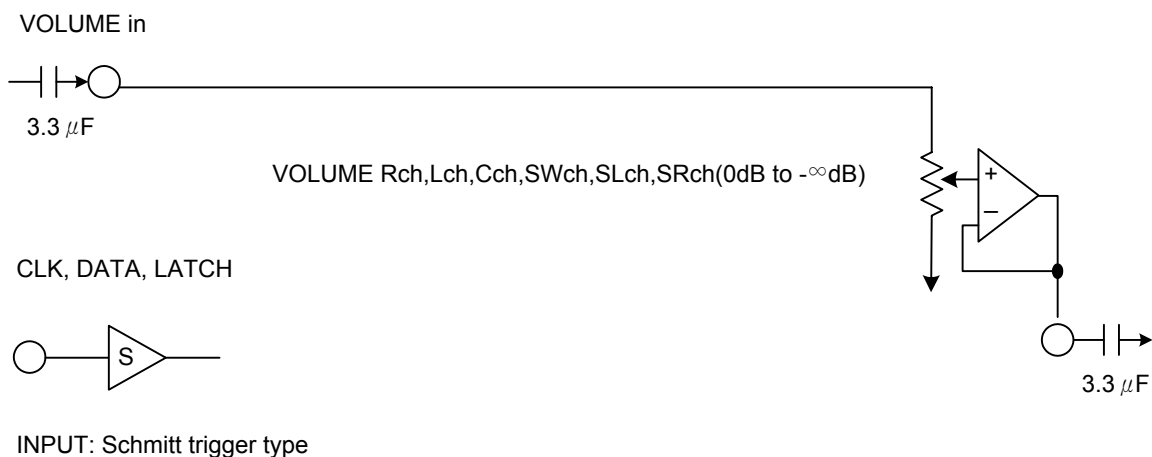

Note:

- (1) The resistance value of Volume change about 18 to 22K $\Omega$  by attenuated condition.
- (2) No built in a zero cross circuit.



6 CHANNELS VOLUME CONTROLLER

APPLICATION EXAMPLE

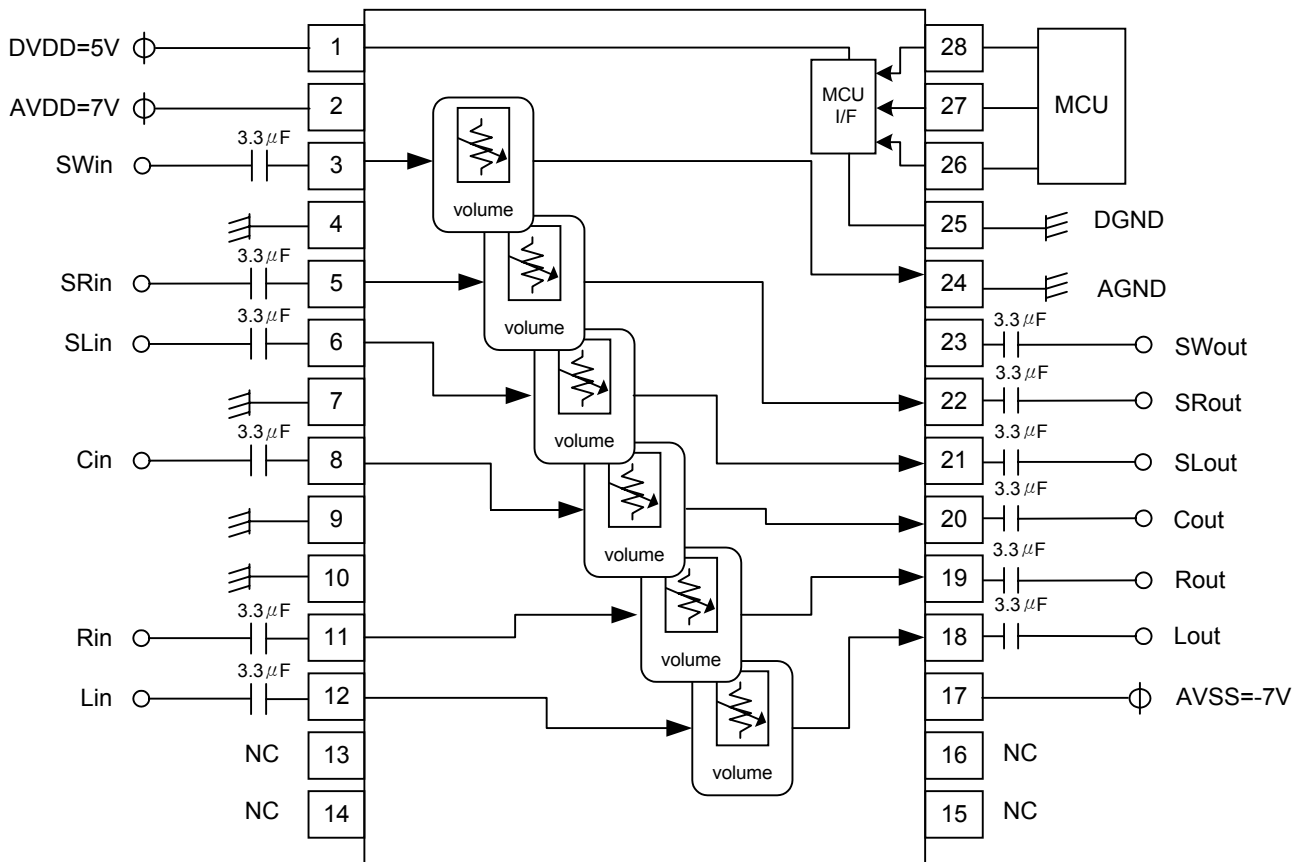

Units Resistance:  $\Omega$  / Capacitance: F



6 CHANNELS VOLUME CONTROLLER

Figure1 : Crosstalk vs. R/L ch

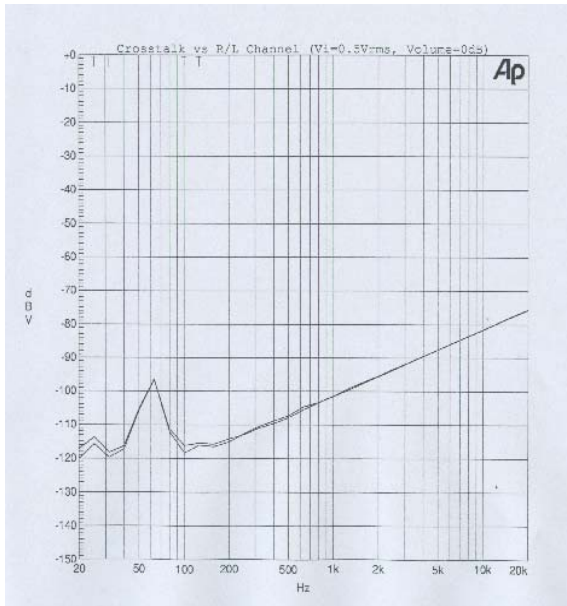
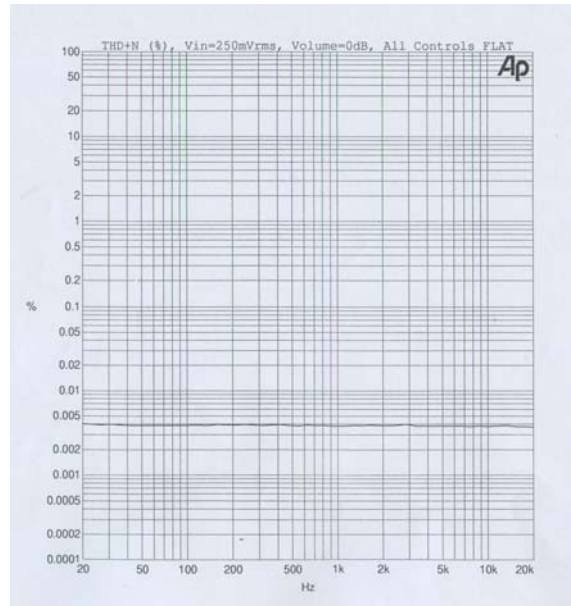

Figure2 : Distortion and Noise vs. Frequency  
(Vin=250mV,AV=0dB,ALL CONTROLS FLAT, VOLUME=0dB,-20dB)





6 CHANNELS VOLUME CONTROLLER

PACKAGE OUTLINE ( SOP28 )

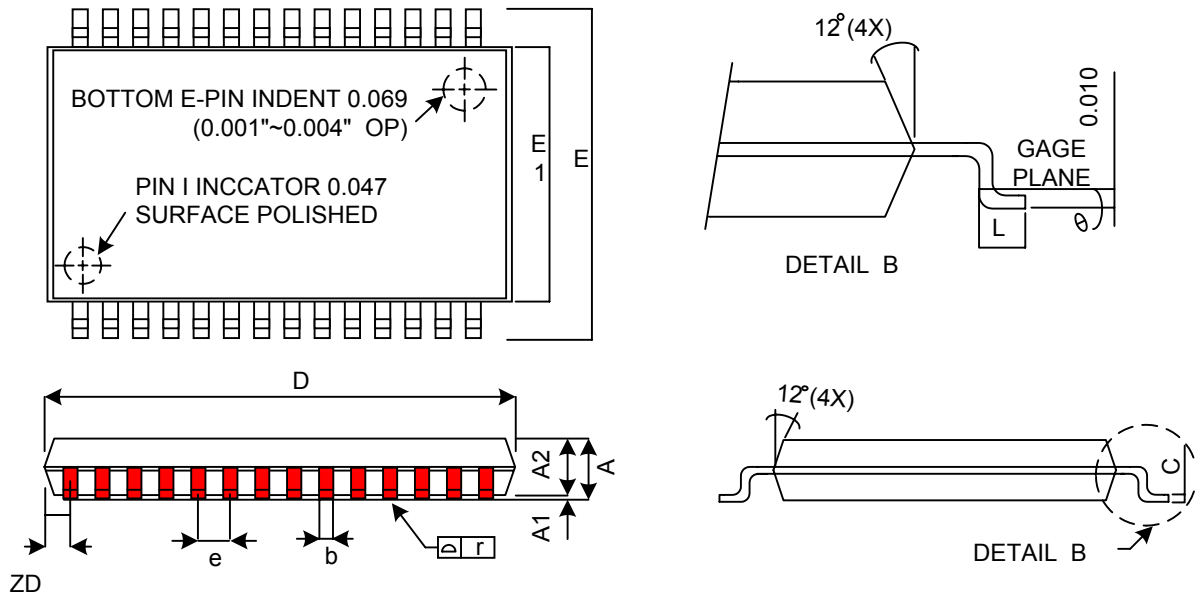

SYMBOLS	DIMENSIONS IN MILLIMETERS			DIMENSIONS IN INCHES		
	MIN	NOM	MAX	MIN	NOM	MAX
A	1.00	—	1.20	0.039	—	0.047
A1	0.05	—	0.15	0.002	—	0.006
A2	0.95	1.00	1.05	0.037	0.039	0.041
b	0.30	0.35	0.45	0.012	0.014	0.018
C	0.12	—	0.21	0.0047	—	0.0083
D	18.313	18.415	18.517	0.721	0.725	0.729
E	11.684	11.836	11.938	0.460	0.466	0.47
E1	10.058	10.160	10.262	0.396	0.400	0.404
e	—	0.800	—	—	0.315	—
L	0.40	0.50	0.60	0.0157	0.020	0.0236
ZD	—	0.805	—	—	0.0317	—
$\theta$	0°	—	8°	0°	—	8°
y	0.00	—	0.076	0.000	—	0.003