

---

## UNIVERSAL PABX TONE GENERATOR

---

### FEATURES

- Generates PBX supervisory tones in PCM format
- Each of these tone streams selectable from 16 tone blocks
- Integrated time slot allocation circuitry
- Separate Intrude Tone for each program
- No noticeable level changes in tones
- Choice of clock frequencies
- Frame synch. signal source (internal/external) selectable
- Watchdog facility
- Eight tone programs
- Low power CMOS technology
- Eight independent PCM tone streams within each program

### PROGRAMMABLE FEATURES

- Tone samples
- Intrude tone frequency
- Tone Cadence timing
- Intrude tone cadence
- Tone to time-slot mapping
- "silence sample" value
- Size of tone blocks

### DESCRIPTION

The SA9401 operates in conjunction with a standard EPROM to generate the system tone plans for the PABX systems of most major countries.

The high level of programmability allows the SA9401 to satisfy a wide variety of tone plans. Furthermore by providing three inputs to select between one of eight tone programs during initialisation, the device effectively facilitates the design of a universally programmable "PABX Processor Card". Because the tone program inputs are latched at the start of each PCM frame the SA9401 minimises the possibility of glitches.

The SA9401 can also generate the PCM Frame synchronising reference signal if required.

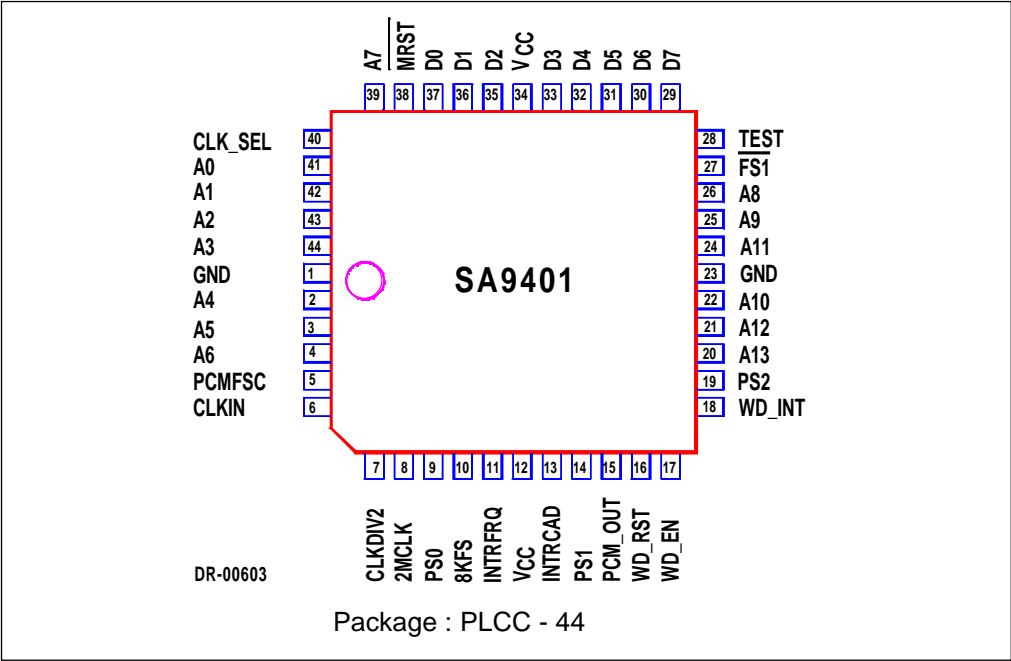

## PIN DESCRIPTION

Pin No	I/O	Designation	Description
1, 23	I	GND	Supply Ground
12, 34	I	VCC	+5V Power Supply
27	I	FS1	Frame Synchronisation (active low)
6	I	CLKIN	Master clock input (either 8192kHz or 2048 KHz dependent on logic level of "CLK_SEL")
8	O	2MCLK	2048 kHz clock derived internally from CLKIN
10	O	8KFS	8 kHz Frame Synchronisation output.
5	O	PCMFSC	8 kHz Auxilliary Frame Synchronisation Output
11	O	INTRFRQ	Square Wave Intrude Tone
13	O	INTRCAD	Intrude Tone Cadence Signal
15	O	PCM_OUT	Tri-state PCM Highway tone output
41, 42, 43, 44, 2, 3, 4, 39, 26, 25, 22, 24, 21, 20	O	A0..A13	EPROM Address Lines

**PIN DESCRIPTION (Continued)**

Pin No	I/O	Designation	Description
37, 36, 35, 33, 32, 31, 30, 29	I	D0..D7	EPROM Data Lines
9, 14, 19	I	PS0, PS1, PS2	Program Select Inputs for Selecting between 1 of 8 tone plans
7	O	CLKDIV2	CLKIN divided by 2 output (i.e. 4096 kHz or 1024 kHz depending on CLK_SEL input)
40	I	CLK_SEL	Selects between CKLIN of 8192 or 2048 kHz and Synchronisation source. 0 = 8192kHz/Internal 1 = 2048kHz/External
28	I	TEST	Used for IC testing purpose. Tied Low during normal operation.
38	I	MRST	Asynchronous Reset Pin. Resets all Internal Flip Flops (active low)
16	I	WD_RST	Watchdog reset input (Rising-edge triggered) Tied high if unused
17	I	WD_EN	Watchdog enable input (active low) Tied high if unused
18	O	WD_INT	Watchdog output (active low, tri-state)

**BLOCK DIAGRAM**

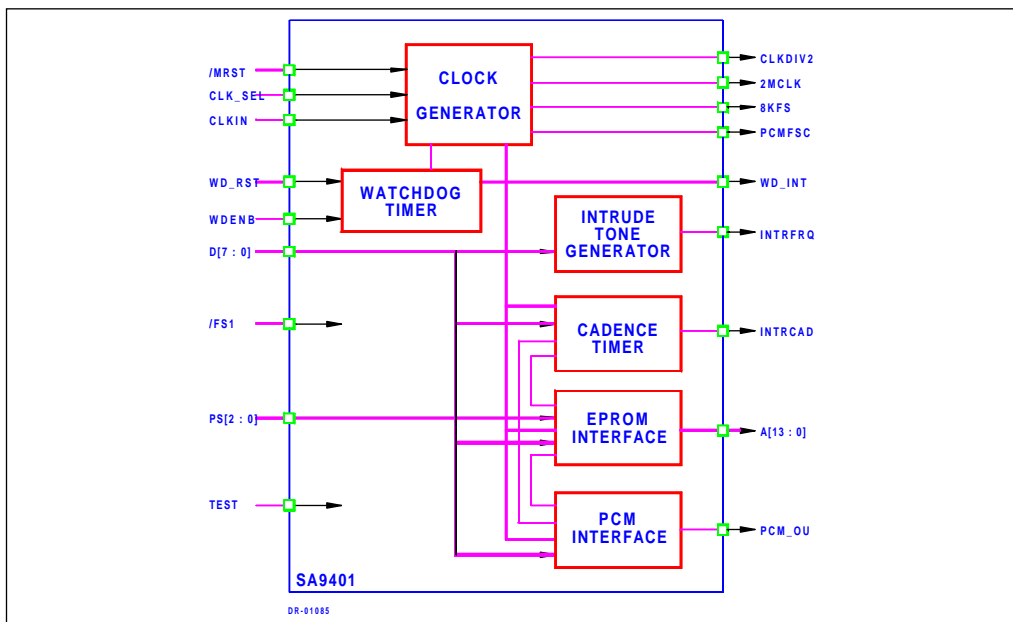

## FUNCTIONAL DESCRIPTION

The design of the SA9401 has been based on the assumption that any supervisory tone used in a PABX (e.g. Dial tone or Busy Tone etc) can be described by a small set of simple parameters and that the tones will be injected into a standard PCM 30 (2048kHz) backplane in either A-law or  $\mu$ -law format.

In the SA9401 a tone is created by repeating a fundamental waveform (or one of two waveforms) which would typically be one cycle of a sinewave or alternatively may be several cycles of a higher frequency signal (say 400 to 1000Hz) modulated by a lower frequency signal. This Tone may then be interrupted (“Cadenced”) so that the tone is effectively switched on and off.

The waveform shape, number of samples per cycle and the cadence can all be set by the system designer in accordance with the related National Standards.

Once a set of tones have been described they may then be injected into the PCM backplane. The time slot associated with each tone can be set by the system designer.

The SA9401 accommodates up to 9 different Tones to form a Tone Plan making ample allowance for Ring, Dial, Busy, Intrude and other Tones. The set of data describing one Tone Plan (waveforms, cadence timings, timeslots etc) is referred to as a Program and is stored in an external EPROM which is addressed directly by the SA9401.

Up to eight Tone Plans may be stored and selected at will to accommodate products for multi-national markets.

## ARCHITECTURE

The architecture of the SA9401 consists of 6 functional blocks each of which is described in detail in the following sections. Refer also to the block diagram.

### Clock Generator

The clock generator circuit derives all the timing for the ic from either a 2048kHz or a 8192kHz clock. The desired Clock is selected by the state of the CLK\_SEL pin (1 for 2048kHz and 0 for 8192kHz).

The CLK\_SEL pin also determines the function of the Frame Sync pin. If CLK\_SEL is low then Internal synchronisation is assumed and FS1 should be tied high. If CLK\_SEL is high then an external Frame Synchronisation source must be connected to /FS1.

The Clock Generator comprises 5 functional blocks.

A **divide-by-4 counter** is enabled only if a 8192kHz clock is selected so that all internal timing is based on 2048kHz. The **Time Slot Counter** keeps track of the Time Slots (0 to 31) in the PCM Frame while the bit position (0 to 7) in each time-slot is tracked by the **Bit Position Counter**. PCM frame synchronisation signals are controlled by the **Frame Generator**. Long cadence intervals are accommodated by the **Five-ms-Timebase** which delivers a 200Hz signal which clocks the Cadence Timers.

## Intrude Tone Generator

This module generates a square wave output based on the master clock of 2048kHz. The Intrude Tone frequency is determined by the contents of the 16-bit **Intrude Tone Register (INTR\_LO and INTR\_HI)** according to the formula:-

$$f_{\text{int}} = 2048\text{kHz}/(2^{*(n+1)})$$

where n is the content of the INTR register.

The range of values in the register (from 0 to 65535) give Intrude tones in the range 15.625Hz to 1024kHz.

## Cadence Timer

In any given Tone Plan the SA9401 assumes that any or all of the 9 (8 PCM tone streams and one squarewave Intrude Tone) tones are required to have their own independently defined cadence. A typical cadence is illustrated in FIGURE 1 above. Each tone is assumed to comprise up to 4 cadence periods which repeat cyclically. The duration of each period is controlled by the **Cadence Timers** which in turn comprise **10-bit Counters**. These timers are clocked by the five\_ms\_timebase generated by the Clock Generator so that intervals of up to 5.12 seconds can be defined with a resolution of 5ms. (10 bits => 1023: 1023\*5ms = 5115ms)

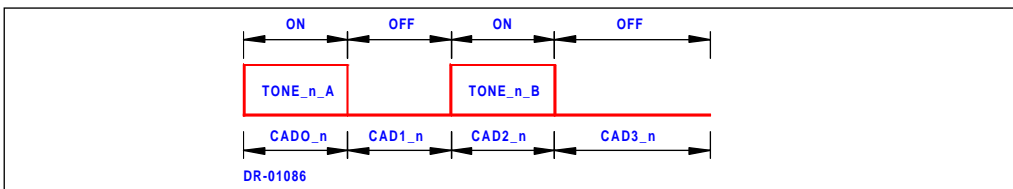

**FIGURE 1: TONE CADENCING**

The **Cadence Controller** controls the loading of the 10-bit counter and the sequencing of the Cadence Position Counter. The duration of each period of the tone is denoted by the parameter:-

$CADm\_n\_LO$  = Period m, Tone stream n low-order 8 bits and

$CADm\_n\_HI$  = Period m, Tone stream n high-order 2 bits

where  $0 \leq m \leq 3$  and  $0 \leq n \leq 8$  (8 = Intrude Tone)

The **Cadence Position Counter** keeps track of the period being generated and during period 0 the SA9401 generates a tone based on one Tone Block (A) while during the period 2 (if used) the samples from another Block (B) are used. During periods 1 and 3 the silence sample is transmitted. This feature allows the sound of the tone to be altered along with the cadence.

A continuous tone is created by loading values of 1(or any non-zero value),0,0,0 into the registers  $CAD0\_n$  to  $CAD3\_n$  respectively. The zero value is interpreted by the SA9401 as an instruction to ignore the period and to process the next one. With the register contents shown the Cadence Controller continuously processes the first (ON) period.



## EPROM Interface

The EPROM Interface controls all aspects of the transfer of program and tone data to the SA9401. This module comprises seven distinct functions.

The **Program Select Register** reflects the settings on pins PS2 - PS0 which are latched into the register at the start of every frame. The mapping of the pin settings to the selected program is by a simple binary code (PS2 = msb).

The **Cycle Register** is loaded with a 9-bit value (**CYCLE**) indicating the number of samples in a Tone Block (or basic waveform). It is assumed that all basic waveforms in a single Tone Plan will have a common size.

Successive samples in a Tone Block are addressed by the 9-bit **Sample Counter** which cycles through from zero to Cycle-1. The current value of this register and the contents of the Cycle Register are fed to a **Comparator** which resets the counter after it reaches the terminal value of Cycle-1.

The required Tone Block (or waveform) is addressed by the **Tone Block Register**. The content of the register is a function of the Program Select and Cadence Controller.

As previously described, Tone Plans are defined in terms of a basic waveform (Tone Block) and a Program of descriptive parameters which together are stored in an external EPROM. Consequently a Data Fetch from the EPROM may retrieve either a Program Instruction or a Tone Sample. In either case the **Address Multiplexer** constructs the address according to the following table.

ADDRESS LINE	Program Instruction Fetch	Tone Sample Fetch
A13	1	0
A12	0	TONE_BLOCK.3
A11	0	TONE_BLOCK.2
A10	0	TONE_BLOCK.1
A9	PSEL2	TONE_BLOCK.0
A8	PSEL1	SAMPLE_COUNT.8
A7	PSEL0	SAMPLE_COUNT.7
A6	PC6	SAMPLE_COUNT.6
A5	PC5	SAMPLE_COUNT.5
A4	PC4	SAMPLE_COUNT.4
A3	PC3	SAMPLE_COUNT.3
A2	PC2	SAMPLE_COUNT.2
A1	PC1	SAMPLE_COUNT.1
A0	PC0	SAMPLE_COUNT.0

The details of the Address mapping will be described later in the **External Data Storage** section



## PCM Interface

The PCM Interface controls all aspects of the transfer of PCM signals onto the PCM highway.

Eight-bit **Tone Registers** store the PCM tone samples and are updated once per PCM frame. Before a PCM word is transmitted to the PCM highway the **Tone Selector** determines whether or not the Cadence controller requires an OFF period. If so then a specific PCM word for Silence (held in the **Silence Register**) is substituted for the tone sample.

The actual transfer of the tone (or silence) samples to the PCM highway is the function of the **Injection Controller**. **Time Slot Registers** indicate to which PCM time-slot the sample is to be injected. These registers (one for each tone stream) comprise 5 address bits and one (high-order) enabling bit. A **Comparator** checks if the Time Slot Register contents match the current PCM time-slot and if so feeds the Tone Sample (or Silence Sample) into the **Parallel In Serial Out** module and the required sample is clocked out via the PCM\_OUT pin. The PCM\_OUT pin is enabled only when samples are being clocked out (ie when the 5 least significant bits of the Time Slot Register matches the current PCM Time Slot and the Time Slot Register MSB is Low) and is held in a tri-state condition at all other times.

## Watchdog Timer

The watchdog timer performs a function completely independently of the Universal Tone Generator. Its operation is described below.

The watchdog timer comprises three I/O pins, viz;

- WD\_EN - an active low input which enables/disables the watchdog.
- WD\_RST - a rising edge triggered input which resets the watchdog timer and prevents the output from resetting the microprocessor.
- WD\_INT - an active low tri-state output which when active, resets a microprocessor.

The watchdog timer operates as follows:

- For the watchdog timer to operate, the WD\_EN pin must be held low (i.e. active). With the WD\_EN pin held high, the WD\_INT output remains tri-stated.  
The delay between WD\_EN going active and a WD\_INT output is 2 seconds.
- The timer is reset every time a rising edge is detected on the WD\_RST pin. The minimum pulse width of the WD\_RST input is two CLKIN periods.
- The WD\_INT output comprises an active low pulse of 5 milliseconds followed by a tri-state period of 1995 milliseconds (assuming no valid WD\_RST pulse is detected within 2 seconds of the previous WD\_RST pulse).

The timing diagram for the Watchdog Timer is given in Figure 2. Note that although the timebase for the Watchdog Timer is always 2048kHz, the WD-EN and WD-RST inputs are strobed at the external clock rate.



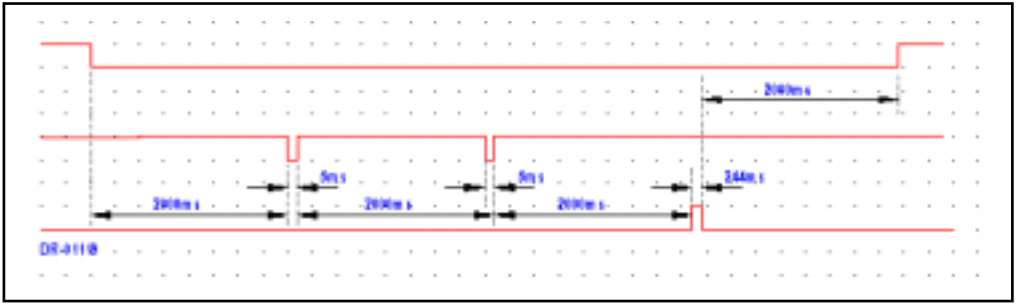
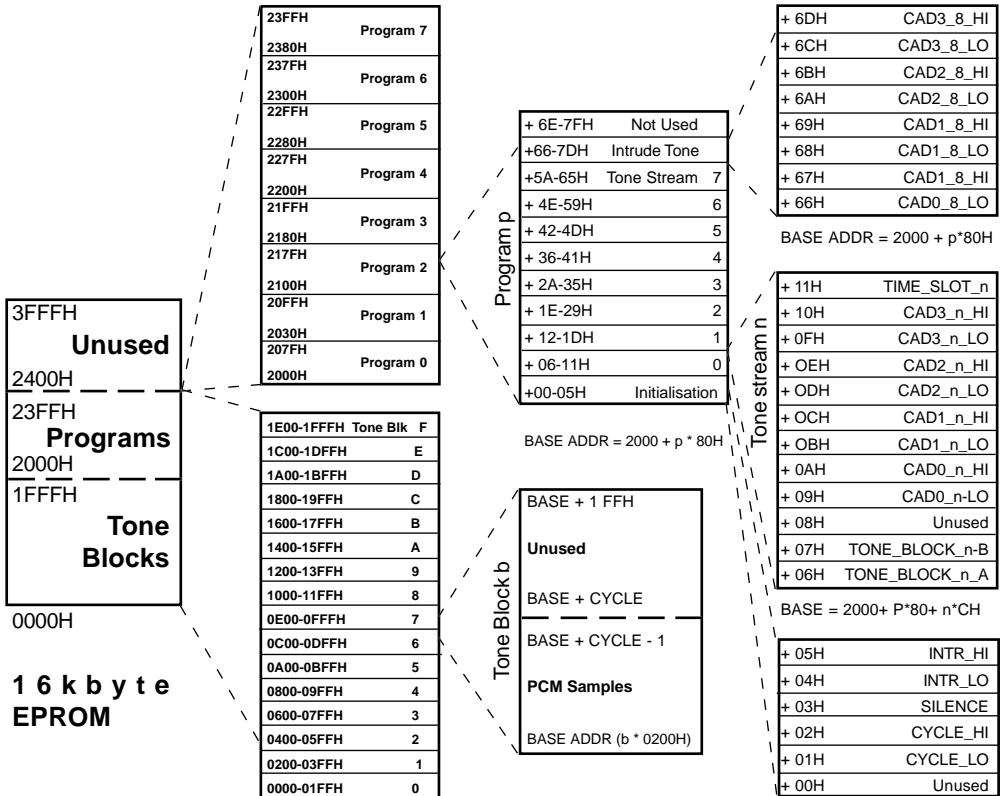

FIGURE 2

EXTERNAL DATA STORAGE

This section describes in detail the names and definition of the parameters which define the Tone Plan for a PABX. Values for these parameters are selected by the system designer in accordance with the relevant standards and are saved in an external EPROM to be addressed by the SA9401.

Reference can be made to the diagram of fig. 3 which defines the memory map of the EPROM.





The EPROM contents can be divided into two distinct sections. The smaller section contains eight Programs, each of which would typically describe all the tones required by a PABX used in a single country. Thus a single EPROM can be programmed to cover up to eight different countries requirements.

The larger part of the EPROM is occupied by the sets of PCM samples which make up the basic waveforms to be used by the SA9401 in creating the familiar supervisory tones. Each of 16 waveforms can contain up to 511 samples of A or  $\mu$  law samples.

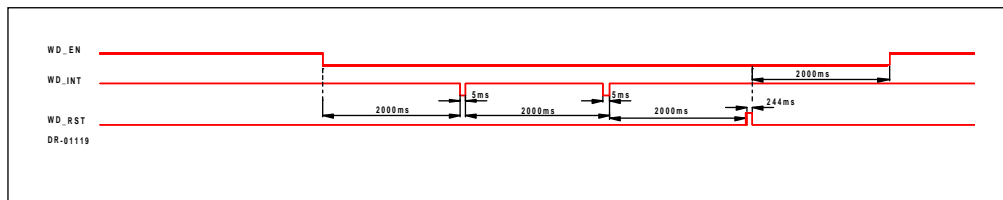

### Program

A single Program comprises one set of **Initialisation** Data, 8 **PCM Tone Streams** with the associated Cadence, Timeslot and Waveform and one **Intrude Tone** with its associated Cadence. Each individual variable is described below.

#### Initialisation

The Initialisation data describes parameters common to all the tones in a given plan.

Variable	bits	Composition	Description
CYCLE	9	CYCLE_HI CYCLE_LO	Identifies the number of samples in the Tone Block. (from 1 to 511)
SILENCE	8		The Silence sample to be used during cadence period 1 and 3.
INTR	16	INTR_HI INTR_LO	The divisor used to generate the Intrude Tone Frequency.

#### PCM Tone Stream

The Tone Stream Data describes the characteristics of a specific PCM Tone. Note that the length of the Cadence periods are defined in multiples of 5ms.

## SA9401

Variable	Bits	Composition	Description
CAD0_8	10	CAD0_8_HI CAD0_8_LO	Length of the first (ON) cadence period.
CAD1_8	10	CAD1_8_HI CAD1_8_LO	Length of the second (OFF) cadence period.
CAD2_8	10	CAD2_8_HI CAD2_8_LO	Length of the third (ON) cadence period.
CAD3_8	10	CAD3_8_HI CAD3_8_LO	Length of the Fourth (OFF) cadence period.

### Intrude Tone

This data describes the characteristics of the Intrude Tone Cadence output on pin INTRCAD of the SA9401.

Variable	Bits	Composition	Description
TONE_BLOCK _n_A	4		Number of the Tone Block to be used in the first Cadence period.
TONE_BLOCK _n_B	4		Number of the Tone Block to be used in the third Cadence period.
CAD0_n	10	CAD0_n_HI CAD0_n_LO	Length of the first (ON) cadence period.
CAD1_n	10	CAD1_n_HI CAD1_n_LO	Length of the second (OFF) cadence period.
CAD2_n	10	CAD2_n_HI CAD2_n_LO	Length of the third (ON) cadence period.
CAD3_n	10	CAD3_n_HI CAD3_n_LO	Length of the Fourth (OFF) cadence period.
TIME_SLOT_ n	6		The number of the Time Slot into which the tone is to be injected. Valid only if MSB is Low.



## Tone Waveform

The frequency content of any desired tone is defined by taking one cycle of the tone (which may be a simple or complex waveform) and calculating the series of PCM samples which would result if that tone were passed through a CODEC. The definition of a waveform is perhaps best illustrated by way of an example.

Consider the case of a PTT dial tone which is a signal of 400Hz modulated at 33.33Hz as illustrated in fig. 4 below. The first step is to identify the lowest frequency in the composite signal, in this case 33.33Hz. Next the designer should confirm that one cycle of the lower frequency component of the signal will contain an integer number of cycles of the higher frequency component. In the example there are exactly 12 cycles of the 400Hz signal contained within the one cycle of the modulating signal. If this is not the case then the tone sample should be designed to contain two or more cycles of the lower frequency tone, subject to the maximum of 512 samples. It is also typical to take a block of the signal which starts and ends at two similar zero crossing points. Although any arbitrary point in the waveform may be used a careless choice may lead to the introduction of undesirable harmonics.

Having chosen a suitable tone sample it is possible to determine the value for CYCLE as the size of the tone block is simply the number of samples (at 8k samples per second) which fall into the waveform chosen. In the example  $CYCLE = 240 \text{ samples} = FOH$ .

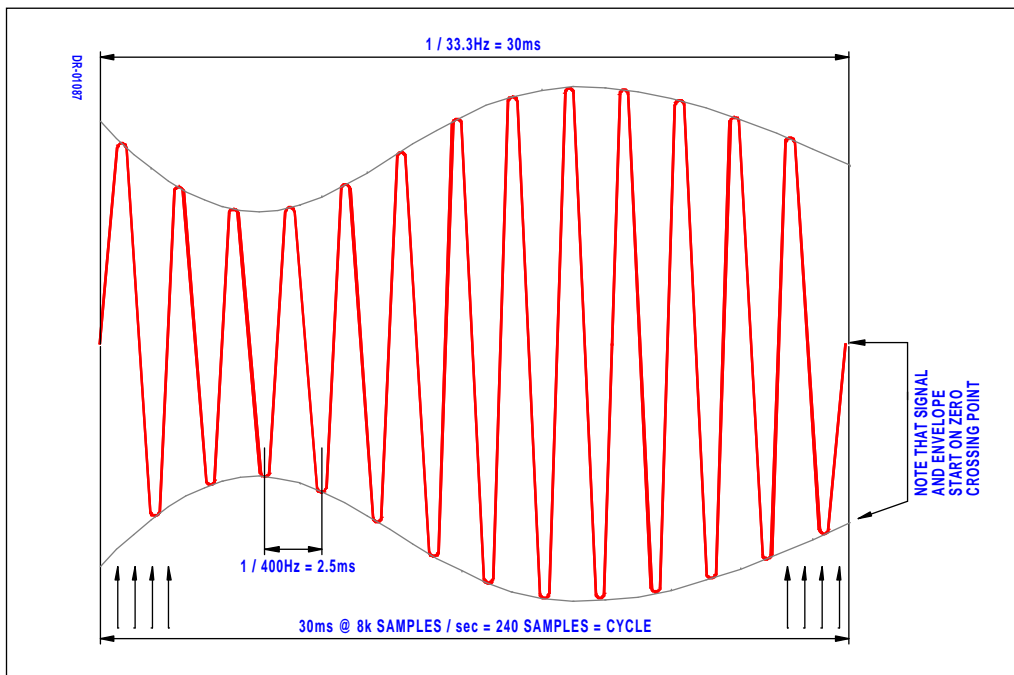

FIGURE 4

400Hz Tone modulated at 33.33Hz.



Finally the system designer should calculate the PCM sample value for each of the 240 samples in the block. The PCM values used may of course be calculated according to either A or  $\mu$ -law and adjusted to suit the required amplitude.

Up to 16 Tone Blocks may be defined each with a maximum of 511 samples. Tone Blocks are stored in the EPROM starting at address  $b * 0200H$  where b is the number of the block from 0 to 15 (decimal).

## APPLICATION INFORMATION

To simplify the translation of Tone Plan requirements to EPROM data SAMES offer a Support Software pack. This elegant package will guide the designer through the definition of Tone Plans and translate the requirements into a hex source file ready for most commonly used PROM programmers. For more details contact your nearest SAMES representative.

## AC PARAMETERS

$T_A = 0^\circ C$  to  $+70^\circ C$ ,  $V_{CC} = 5V \pm 5\%$ . Load Cap  $\leq 50pF$

AC PARAMETERS	SYM	MIN	TYP	MAX	UNITS
Propagation delay of outputs synchronous to CLKIN (i.e. 2MCLK, CLKDIV2, and WD_INT) relative to CLKIN rising clock edge	$Pd_{8M}$	0	20	40	ns
Propagation delay of outputs synchronous to 2MCLK (i.e. INTRFRQ, 8KFS, PCMFSC, INTRCAD, PCM_OUT, A0..A13)	$Pd_{2M}$	0	20	40	ns
Delay to float of PCM_OUT AFTER LAST BIT OF TIME-SLOT OUTPUT	$Pf_{po}$	0	30	60	ns
Delay to float of WD_INT after going inactive	$Pf_{wd}$	0	30	60	ns
D0..D7 setup to 2MCLK rising edge	$Sd_D$	100			ns
D0..D7 hold after 2MCLK rising edge	$Hd_D$	0			ns

## Absolute Maximum Ratings\*

Parameters	Symbol	Min	Max	Unit
Supply Voltage	$V_{DD}$	-0.3	7.0	V
Voltage on any I/O pin	$V_I/V_O$	-0.3	$V_{DD} + 0.3$	V
Current on any I/O pin	$I_I/I_O$	-10	+10	mA
Storage Temperature	$T_{SIG}$	-55	+125	$^\circ C$
Package Power Dissipation	$P_D$		1000	mW

\* Stress above those listed under "Absolute Maximum Ratings" may cause permanent damage to the device. This a stress rating only. Functional operation of the device at these or any other condition above those indicated in the operational sections of this specification, is not implied. Exposure to Absolute Maximum Ratings for extended periods may effect device reliability.



**DC Characteristics**
 $T_A = 0 \text{ to } 70^\circ\text{C}; V_{DD} = 5\text{V} \pm 5\%; V_{SS} = 0\text{V}$ 

Parameter	Symbol	Limit Values		Unit	Test Conditions
		Min.	Max.		
L-input voltage	$V_{IL}$		1.0	V	$V_{DD} = 5\text{V}$
H-input voltage	$V_{IH}$	4.0	$V_{DD} + 0.3$	V	$V_{DD} = 5\text{V}$
L-input voltage	$V_{OL}$		0.5	V	$I_{OL} = 0.1\text{mA}$
H-output voltage	$V_{OH}$	4.5		V	$I_{OH} = 0.1\text{mA}$
Operating Frequency			2.273	MHz	$V_{DD} = 5\text{V}$
Input leakage current	$I_{LI}$	-10	10	$\mu\text{A}$	$0\text{V} < V_{IN} < V_{DD}$
Output leakage current	$I_{LO}$	-10	10	$\mu\text{A}$	$0\text{V} < V_{OUT} < V_{DD}$

**Characteristics**
 $T_A = 25^\circ\text{C}; V_{DD} = 5\text{V} \pm 5\%; V_{SS} = 0\text{V}$ 

Parameter	Symbol	Limit Values		Unit
		Min.	Max.	
Input capacitance	$C_{IN}$		10	pF
Output capacitance	$C_{OUT}$		15	pF
I/O	$C_{IO}$		20	pF

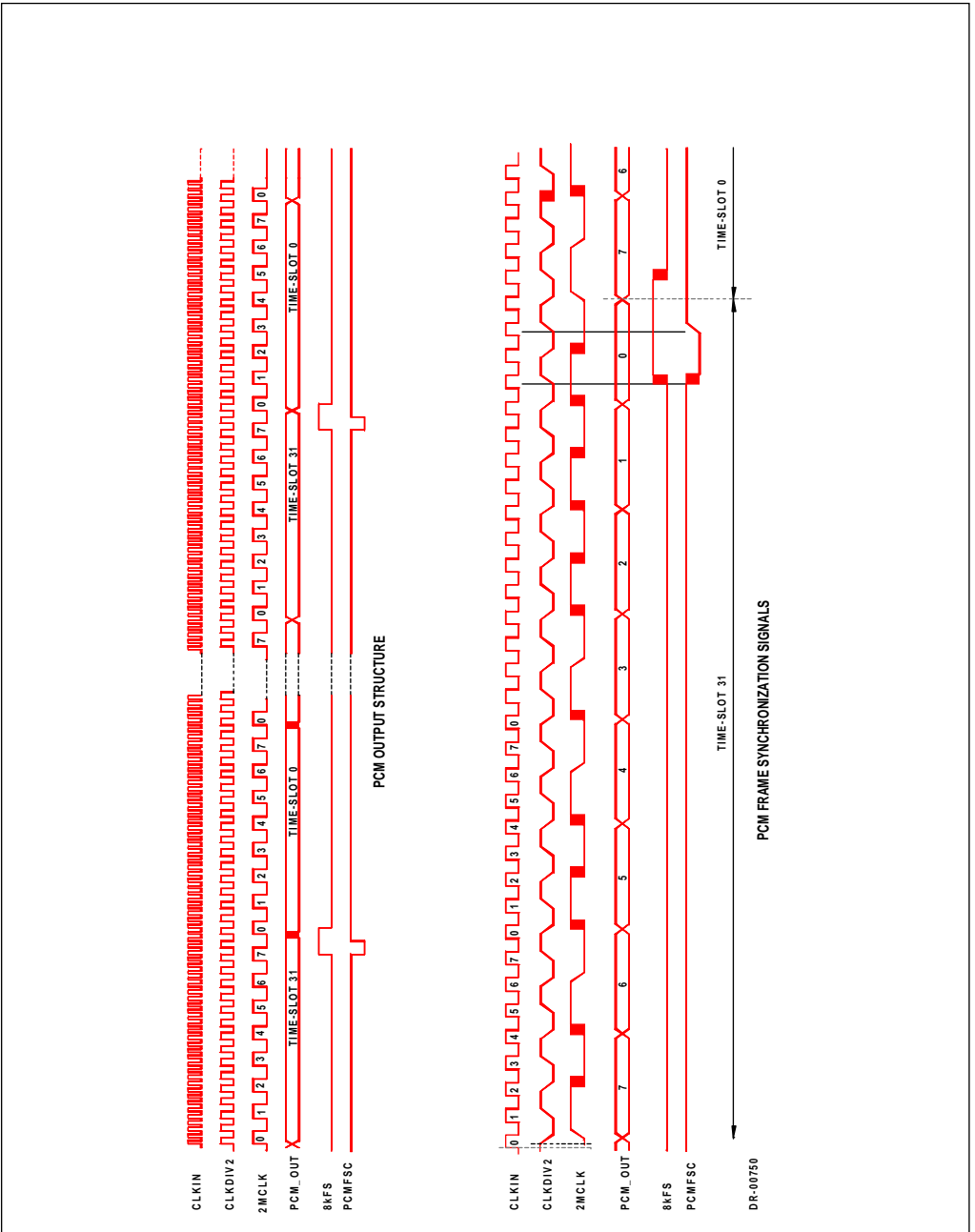

Figure 5 - Timing Diagram (CLK\_SEL=0, CLKIN=8MHz, Internal Sync.)

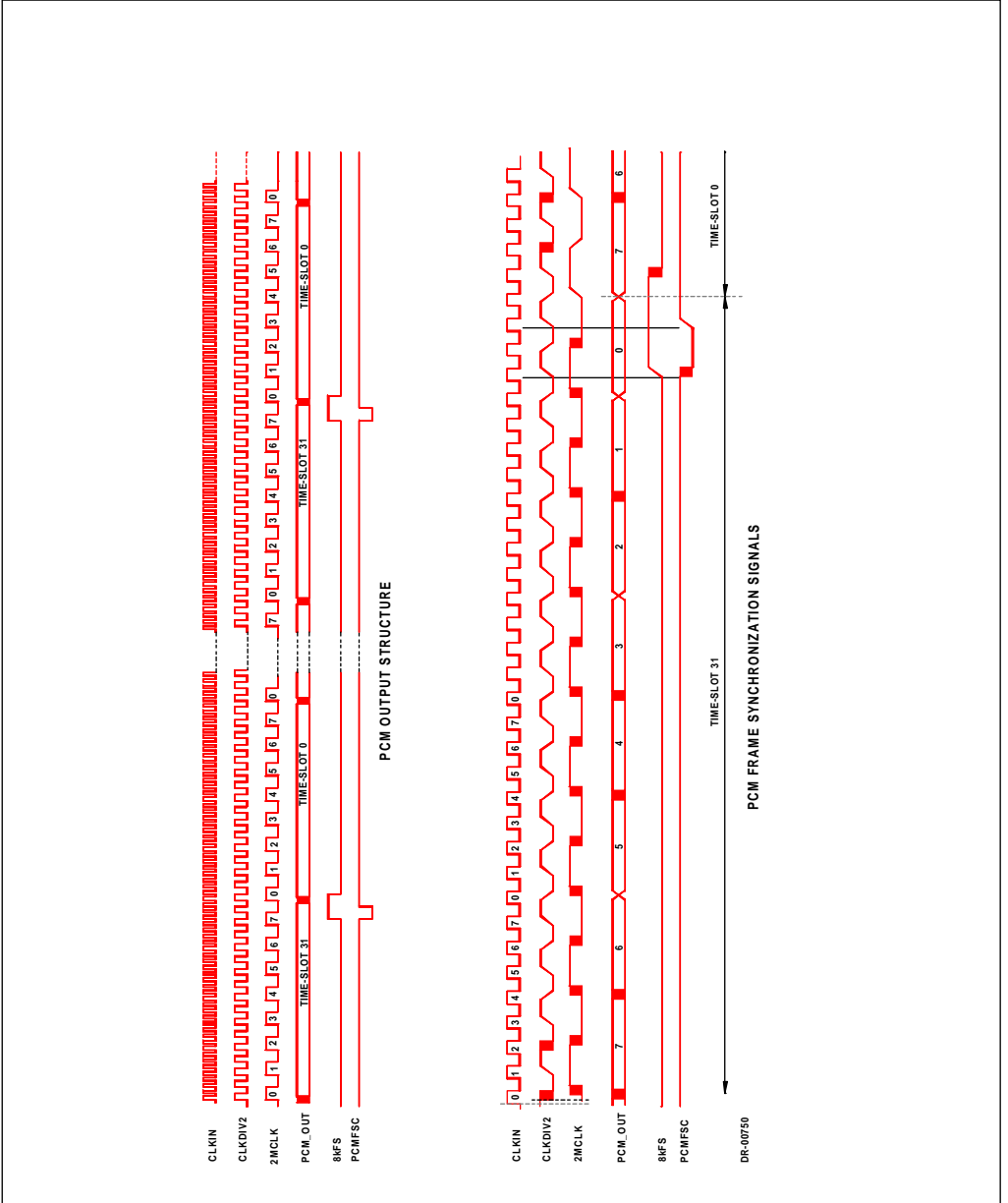

Figure 6 - TIMING DIAGRAMS (CLK\_SEL = 1, CLKIN = 2MHz, EXTERNAL SYNC.)

**Disclaimer:** The information contained in this document is confidential and proprietary to South African Micro-Electronic Systems (Pty) Ltd ("SAMES") and may not be copied or disclosed to a third party, in whole or in part, without the express written consent of SAMES. The information contained herein is current as of the date of publication; however, delivery of this document shall not under any circumstances create any implication that the information contained herein is correct as of any time subsequent to such date. SAMES does not undertake to inform any recipient of this document of any changes in the information contained herein, and SAMES expressly reserves the right to make changes in such information, without notification, even if such changes would render information contained herein inaccurate or incomplete. SAMES makes no representation or warranty that any circuit designed by reference to the information contained herein, will function without errors and as intended by the designer.

Any sales or technical questions may be posted to our e-mail address below:  
[energy@sames.co.za](mailto:energy@sames.co.za)

For the latest updates on datasheets, please visit our web site:  
<http://www.sames.co.za>

**South African Micro-Electronic Systems (Pty) Ltd**

P O Box 15888,  
Lynn East,  
0039  
Republic of South Africa,

33 Eland Street,  
Koedoespoort Industrial Area,  
Pretoria,  
Republic of South Africa

Tel: 012 333-6021  
Fax: 012 333-8071

Tel: Int +27 12 333-6021  
Fax: Int +27 12 333-8071