

Typical Applications

- Automotive Navigation
- Asset Tracking
- Fleet Management
- Telematics
- Marine Navigation

Product Description

The RFMD Global Positioning System (GPS) Receiver is a plug-n-play module designed for OEM use. The 12-parallel-channel GPS receiver works in a wide variety of end products including: marine navigation, telematics, automotive navigation, and asset tracking. The GPS receiver processes signals from all the visible GPS satellites broadcasting RF navigation information. "All-in-view" satellite tracking produces highly accurate, smoothed navigation data. The data is relatively immune to the position jumps that occur when fewer satellites are monitored. Designed to withstand harsh industrial environments, the GPS receiver performs robustly in situations where extreme vehicle movement or high signal blockage are concerns (such as dense urban areas).



Optimum Technology Matching® Applied

- | | | |
|-------------------------------------|-----------------------------------|--|
| <input type="checkbox"/> Si BJT | <input type="checkbox"/> GaAs HBT | <input type="checkbox"/> GaAs MESFET |
| <input type="checkbox"/> Si Bi-CMOS | <input type="checkbox"/> SiGe HBT | <input checked="" type="checkbox"/> Si CMOS |
| <input type="checkbox"/> InGaP/HBT | <input type="checkbox"/> GaN HEMT | <input checked="" type="checkbox"/> SiGe Bi-CMOS |

Package Style: 38mmx38mm

Features

- Fast satellite time-to-first-fix (TTFF) with a Rapid Acquisition Module
- Small footprint: 38mmx38mm
- Supports 3D and 2D navigation modes
- Automatic cold start acquisition process

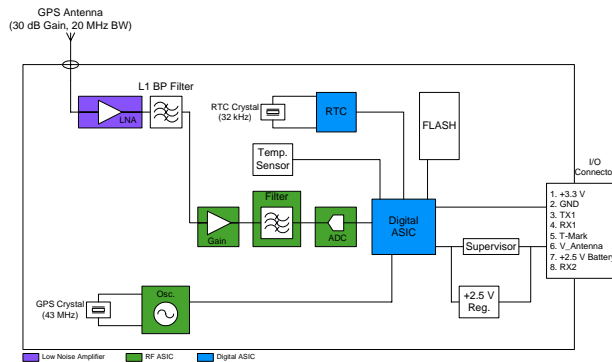

Functional Block Diagram

Ordering Information

RF8000	Global Positioning System Receiver (with straight I/O connector and straight MCX RF connector)
RF8001	GPS Receiver (with straight I/O connector and right angle MCX RF connector)
DK8000	Global Positioning System Receiver Evaluation Kit

RF Micro Devices, Inc. Tel (336) 664 1233
 7628 Thorndike Road Fax (336) 664 0454
 Greensboro, NC 27409, USA <http://www.rfmd.com>

RF8000

Absolute Maximum Ratings

Parameter	Rating	Unit
Supply Current	210	mA
RF Input Level	-20	dBm
Operating Ambient Temperature	-40 to +85	°C
Storage Temperature	-40 to +85	°C



Caution! ESD sensitive device.

RF Micro Devices believes the furnished information is correct and accurate at the time of this printing. However, RF Micro Devices reserves the right to make changes to its products without notice. RF Micro Devices does not assume responsibility for the use of the described product(s).

Parameter	Specification			Unit	Condition
	Min.	Typ.	Max.		
External Power Requirements¹					
Voltage	3.17	3.3	3.43	V _{DC}	Operate mode
	1.65	2.5	2.7	V _{DC}	Battery backup mode
Power Consumption		400		mW	1 second updates
		135		mW	1 minute updates ²
		30		mW	5 minute updates ²
		6		μA	Battery backup mode
Ripple Peak-to-Peak			100	mV	Operate mode
			N/A		Battery backup mode
Signal Acquisition Performance					
Accuracy					
Horizontal		5.8		m	2d RMS
Vertical		9.7		m	2d RMS
Velocity		0.06		m/s	1 Sigma
DGPS		<1		m	2d RMS
Solution Update Rate		1		sec	
Time Mark		1		sec	1 s ± 100 ns (1 Sigma)
Serial Data Output Protocol					Binary, NMEA-0183
Serial Ports					
Primary Port		19,200		bps	Binary, no parity, 8 data bits, 1 stop bit
Auxiliary Port		9600		bps	RTCM SC-104, no parity, 8 data bits, 1 stop bit
Antenna Requirements					
Frequency		1575		MHz	
Antenna Gain		3		dBic	At 90° elevation
Amplifier Gain	30			dB	Including cable loss
Amplifier Filter Noise Bandwidth	20			MHz	At the 3dB points
Noise Figure			2.5	dB	
Connector Type					MCX
Amplifier Voltage, 3V _{DC} to 5V _{DC}			50	mA	Supplied by OEM
RF Signal Environment					
RF Input Frequency		1575.42		MHz	L1 frequency band
RF Input Power	31			dB-Hz	
Sensitivity		-113		dBm	Costas threshold

¹Power must be within the specified limits within 40ms after power turn-on.

²Results with Power Management software using external hardware control.

This datasheet is for Software version 4.7.0 or later.

Parameter	Specification			Unit	Condition
	Min.	Typ.	Max.		
Environmental Requirements					
Cooling (Operating/Storage) Temperature (Operating/Storage)	-40	Free air convection	+85	°C	Relative humidity up to 95% non-condensing or a wet-bulb temperature of +35°C, which- ever is less.
Humidity			95	%	
Altitude	-1000		+60,000	ft	Acquisition and navigation (meters per second)
Maximum Vehicle Dynamic			515	m/s	
Jerk		5		m/s ³	
Acceleration		4		G	

RF8000

Package Style Module - 38mmx38mm RF8000 (straight MCX RF connector configuration)

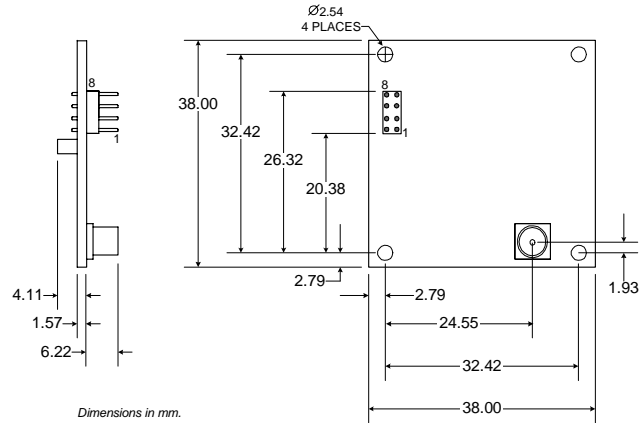

RF8001 (right angle MCX RF connector configuration)

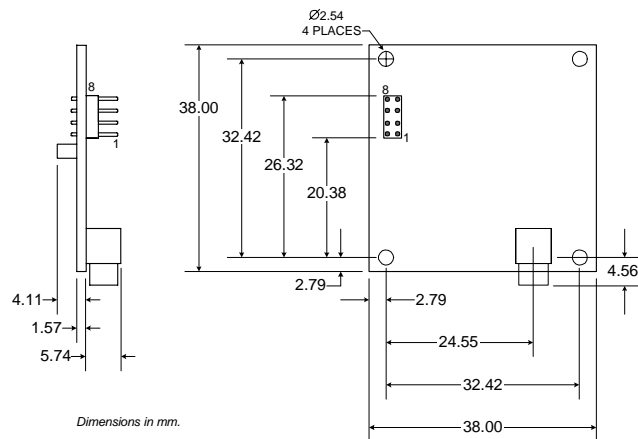

I/O Connector Detail (Samtec part number: TMMH-104-01-F-D)

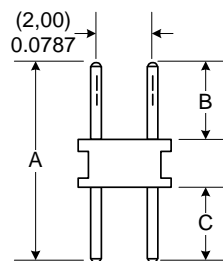

LEAD STYLE	A	B	C
-01	(7,67) 0.302	(3,20) 0.126	(2,46) 0.097

Theory of Operation

The RFMD GPS receiver is a single-board, 12 parallel-channel engine designed for OEM use. The GPS receiver processes signals from the visible GPS satellites broadcasting RF navigation information. “All-in-view” satellite tracking produces highly accurate, smoothed navigation data. The data is relatively immune to the position jumps that occur when fewer satellites are monitored. Designed to withstand harsh industrial environments, the GPS receiver performs robustly in situation (such as dense urban areas) where extreme vehicle movement or high signal blockage are concerns.

When fewer than four satellites are available or when operating conditions require, the GPS receiver supports 2D navigation. To calculate a fix while in 2D navigation mode, the receiver uses either the last altitude determined while in 3D navigation mode, or data supplied by the user.

Satellite acquisition can be obtained under most initialization situations, as long as the receiver can “see” the satellites. Rapid time to first fix (TTFF) is a feature of the Rapid Search Engine. The flexible satellite acquisition system takes advantage of all available information to provide rapid TTFF, even without user initialization. To minimize TTFF when primary power is removed from the receiver, a DC supply voltage maintains the real time clock (RTC). This allows the GPS receiver to use the prior position data and satellite information stored in the GPS receiver’s flash memory.

The receiver has two independent, asynchronous serial input/output ports. The receiver’s primary serial port outputs navigation data and accepts commands in the NMEA-0183 or binary message formats. The receiver’s secondary serial port accepts differential GPS (DGPS) corrections in RTCM SC-104 format. See the “Message Definitions” section for more information.

Receiver Architecture

The GPS receiver chipset includes all the radio frequency (RF) direct sampling and amplification circuitry. These circuits present both the sign and magnitude of sampled data to the digital ASIC. The digital ASIC contains an integral microprocessor (PowerPC^R 401), the GPS signal processing, SRAM, and the RTC. Memory and other supporting components are needed to make a complete navigation system.

Receiver Operation

The receiver requires 3.3V DC primary input power.

The receiver’s antenna must have visibility of the sky in order to acquire enough satellites to produce a navigation solution. While this is usually not a problem outdoors, operation indoors or in a vehicle may require that the antenna be located with an unobstructed view of the sky. If the satellites are blocked from the receiver’s antenna, the receiver will take longer to acquire a position. If fewer than four satellites are available, the receiver may be able to determine a valid 2D position solution by using altitude aiding.

Signal Acquisition Modes

The GPS receiver supports the following four signal acquisition modes, depending on the availability of critical data.

Cold Start	In this mode, the receiver has valid almanac and frequency standard parameters available in memory. The receiver enters this mode on start-up when battery back-up power is not maintained.
Warm Start	In this mode, the receiver has the following valid data either available in memory or provided by the user at initialization: position, time, almanac, and frequency standard parameters. The receiver enters this mode following a long power-off cycle (greater than a few hours) when battery back-up power is maintained.
Hot Start	In this mode, the receiver has the following valid data available in memory: position, velocity, time, ephemeris, almanac, and frequency standard parameters. The receiver enters this mode following a software reset or on short power-off cycles (less than a few hours) when battery back-up power is maintained.
Reacquisition	In this mode, the receiver has experienced a signal blockage for a short period of time (less than 10seconds) that was preceded by a period of continuous navigation.

RF8000

Table 1 (below) indicates the time to first fix (TTFF) when operating in each of the signal acquisition modes.

Table 1. Signal Acquisition Mode Performance

Acquisition Mode	TTFF ^{1,2} (seconds)	Initial Position Tolerance (3 Sigma)			Maximum Almanac Age (weeks)	Maximum Ephemeris Age (hours)
		Position (km)	Velocity (m/sec.)	Time (minutes)		
Cold Start	44	N/A ³	N/A ³	N/A ³	1	N/A ³
Warm Start	40	100	75	5	1	N/A ³
Hot Start	10	100	75	5	1	4
Reacquisition	1	100	75	5	1	4

¹Typical values.

²Times given are valid at 25°C with no signal blockage.

³Not available in real time to the receiver.

Navigation Modes

The GPS receiver supports three navigation modes: three-dimensional (3D), two-dimensional (2D) and Differential GPS (DGPS).

When four or more satellites are available with good geometry, the receiver enters the 3D navigation mode.

When fewer than four GPS satellites are available, or when a fixed altitude can be used to produce an acceptable result, the GPS receiver enters the 2D navigation mode. To calculate a fix in 2D navigation mode, the receiver uses either the last altitude determined in 3D navigation mode or data supplied by the user. In 2D navigation, navigational accuracy is primarily determined by the relationship of the fixed value of altitude to the true altitude of the antenna.

When four or more satellites are available with differential corrections, the receiver enters the DGPS navigation mode.

Accuracy is a function of the entire GPS system, including the geometry of the satellites at the time of measurement. Individual GPS receivers have very little influence over position accuracy. Navigational accuracies are provided in Table 2.

Table 2. Navigational Accuracy

Position (2drms, 95% All-in-View)		Velocity	DGPS	Time
Horizontal	Vertical			
5.8m	9.7m	0.06 m/s	<1 m	100ns

Power Modes

The GPS receiver has the following three power modes.

Off Mode The receiver is completely de-energized at all DC supplies, input signals and control signals.

Operate Mode The receiver operates normally when an external DC supply is connected to the receiver's primary input terminal, V3_3P.

Battery Back-up Mode The receiver enters battery back-up mode when the primary input power voltage is removed, provided an external DC supply is connected to the RTC terminal, V2_5BU. If the receiver is powered up in this mode, it uses the current time from the RTC and critical satellite data stored in flash memory to achieve rapid TTFF.

Electrical Requirements

The host system supplies power as specified in the parameter table.

Antenna Power

The GPS receiver passes the voltage applied to the V_ANT pin on the I/O connector to the center conductor of the RF connector. The voltage to V_ANT can be either positive or negative and can range up to 15V_{DC}.

NOTE: No form of current limiting is provided, and damage to the board may result if the RF center conductor is shorted to ground. Antenna preamp, pass-through current must be limited outside the receiver.

Antenna Sense Circuit (Optional Feature)

The optional antenna sense feature is useful for verifying the proper connection to the GPS antenna. With this feature implemented, the GPS receiver is capable of detecting antenna undercurrent and overcurrent conditions. The antenna sense status can be requested using the IBIT message and the results will be reported in the OBIT message.

NOTE: If the optional antenna sense circuit is used, the voltage to the V_ANT pin on the GPS receiver connector may either be +3.3V or 5V_{DC}, depending on the specific antenna requirements. DC current is limited on the board to approximately 100mA.

Input/Output Signals

Signals are listed by pin number and described in Table 3. All digital I/O signals are 2.5V_{DC} CMOS buffered signal levels, tolerant of 3.3V_{DC}.

Table 3. Input/Output Connections

Pin Number	Signal Name	Description
1	V3_3P	Main power input to the receiver. Input power requirements are defined in Table 3.
2	GND	DC ground to the receiver.
3	TX1	Primary asynchronous full-duplex serial data port transmit (TX) line. Binary and NMEA message protocols are supported. The default settings are: Message format Binary Baud 19200bps Parity None Data Bits 8 Stop Bit 1 For additional information, see the GPS receiver evaluation kit user manual.
4	RX1	Primary asynchronous full-duplex serial data port receive (RX) line. Binary and NMEA message protocols are supported. The default settings are: Message format Binary Baud 19200bps Parity None Data Bits 8 Stop Bit 1 For additional information, see the GPS receiver evaluation kit user manual.
5	TMARK	UTC time-mark pulse, one pulse per second. The Binary message OTMP contains the UTC time associated with the time-mark pulse.
6	V_ANT	Provides a power connection to the center conductor of the RF connector.
7	V2_5BU	Provides a back-up power connection for the receiver's real time clock (RTC). Input power requirements are defined in Table 3.
8	RX2	Auxiliary asynchronous full-duplex serial data port receive (RX) line. DGPS RTCM SC-104 message protocol is supported. The default settings are: Message format RTCM SC-104 Baud 9600 Parity None Data Bits 8 Stop Bit 1 For additional information, see the GPS receiver evaluation kit user manual.

Message Definitions

The following Binary and NMEA message definitions are provided in the RFMD GPS Receiver User Manual (available with purchase of the GPS Receiver Evaluation Kit). Contact RFMD customer service for more information.

Table 4. Binary Output Messages

Binary Message	Description	Default On
ONVD	Navigation Solution Data	Yes
OSAT	Visible Satellites	On update
OCHS	Channel Status	Yes
ODGS	DGPS Status	No
ODGC	DGPS Configuration	No
ONOC	Navigation Operational Configuration	Once at Power-Up/Reset
ONVC	Navigation Validity Configuration	Once at Power-Up/Reset
ONPC	Navigation Platform Configuration	No
OCSC	Cold Start Configuration	Once at Power-Up/Reset
OEMA	Elevation Mask Angle Configuration	Once at Power-Up/Reset
ODTM	Map Datum Select	Once at Power-Up/Reset
ODTU	User Datum Definition	No
OTMP	UTC Time Mark Pulse	Yes
OALD	Download Almanac Data	No
OEPD	Download Ephemeris Data	No
OUTD	Download UTC/IONO Data	No
OSHM	Satellite Health Masking Configuration	No
OSID	Receiver Software ID	Once at Power-Up/Reset
OBIT	Built-in-Test Results (ACK)	No
OFSH	Command Flash Upload (ACK)	No

Table 5. Binary Input Messages

Binary Message	Description
INIT	Navigation Initialization
IDGC	DGPS Configuration
INOC	Navigation Operational Configuration
INVC	Navigation Validity Configuration
INPC	Navigation Platform Configuration
ICSC	Cold Start Configuration
IEMA	Elevation Mask Angle Configuration
IDTM	Map Datum Select
IDTU	User Datum Definition
IALD	Command Almanac Upload
IEPD	Command Ephemeris Upload
IUTD	Command UTC/IONO upload
ISHM	Satellite Heal Masking Configuration
IRST	Command Reset
IFSH	Command Flash Upload
ILOG	Message Log Control
IIOC	Input/Output Port Configuration
IMPC	Message Protocol Configuration
IBIT	Command Built-in-Test

Table 6. NMEA Output Messages

NMEA Message	Description	Default On
SID	Software Version	Once at Power-Up/Reset
GGA	GPS Fix Data	Yes
GLL	Geographic Position: Latitude/Longitude	No
GSA	GPS DOP and Active Satellites	Yes
GSV	GPS Satellites in View	On Update
RMC	Recommended Minimum Specific GPS/Transit Data	Yes
VTG	Track Made Good and Ground Speed	No
BTO	Built-in-Test Results (ACK)	No
CHS	Channel Status Data	Yes

Table 7. NMEA Input Messages

NMEA Message	Description
INT	Receiver Initialization
LOG	Message Log Control
IOC	Input/Output Port Configuration
MPC	Message Protocol Configuration
RST	Command Reset
BTI	Command Built-in-Test Required

Table 8. RTCM SC-104 Messages

RTCM Message	Description
Type 1	Differential GPS Corrections
Type 2	Delta Differential GPS Corrections
Type 9	Partial Satellite Set Differential Corrections

RF8000