

MDLM111-X REV 0B0

 Original Creation Date: 01/10/01
 Last Update Date: 04/20/01
 Last Major Revision Date:

VOLTAGE COMPARATOR
General Description

The LM111, is a voltage comparator that has input currents nearly a thousand times lower than devices such as the LM106 and LM710. It is also designed to operate over a wider range of supply voltages: from standard $\pm 15V$ op amp supplies down to the single 5V supply used for IC logic. Its output is compatible with RTL, DTL and TTL as well as MOS circuits. Further, it can drive lamps or relays, switching voltages up to 50V at currents as high as 50mA.

Both the inputs and the outputs of the LM111, can be isolated from system ground, and the output can drive loads referred to ground, the positive supply or the negative supply. Offset balancing and strobe capability are provided and outputs can be wire OR'ed. Although slower than the LM106 and LM710 (200 ns response time vs 40ns) the devices are also much less prone to spurious oscillations. The LM111 has the same pin configuration as the LM106 and LM710.

Industry Part Number

LM111

NS Part Numbers

 LM111E-SMD
 LM111H-SMD
 LM111J-8-SMD
 LM111WG-SMD

Prime Die

LM111

Controlling Document

SEE FEATURES SECTION

Processing

MIL-STD-883, Method 5004

Quality Conformance Inspection

MIL-STD-883, Method 5005

Subgrp	Description	Temp (°C)
1	Static tests at	+25
2	Static tests at	+125
3	Static tests at	-55
4	Dynamic tests at	+25
5	Dynamic tests at	+125
6	Dynamic tests at	-55
7	Functional tests at	+25
8A	Functional tests at	+125
8B	Functional tests at	-55
9	Switching tests at	+25
10	Switching tests at	+125
11	Switching tests at	-55

Features

- Low Input Bias Current.
- Low Input Offset Current.
- Wide Differential Input Voltage.
- Power Supply Voltage, Single 5V to ± 15 V.
- Offset Voltage Null Capability.
- Strobe Capability.

CONTROLLING DOCUMENTS:

LM111E-SMD	5962-8687701Q2A
LM111H-SMD	5962-8687701QGA
LM111J-8-SMD	5962-8687701QPA
LM111WG-SMD	5962-8687701QZA

(Absolute Maximum Ratings)

(Note 1)

Positive Supply Voltage		+30.0V
Negative Supply Voltage		-30.0V
Total Supply Voltage		36V
Output to Negative Supply Voltage		50V
GND to Negative Supply Voltage		30V
Differential Input Voltage		±30V
Sink Current		50mA
Input Voltage (Note 2)		±15V
Power Dissipation (Note 3)		500mW
Output Short Circuit Duration		10 sec.
Maximum Strobe Current		10mA
Operating Temperature Range		-55 C ≤ Ta ≤ 125 C
Thermal Resistance		
ThetaJA		
8 Ld DIP	(Still Air @ 0.5W)	134 C/W
	(500LF/Min Air flow @ 0.5W)	76 C/W
8 Ld Metal Can Pkg	(Still Air @ 0.5W)	162 C/W
	(500LF/Min Air flow @ 0.5W)	92 C/W
10 CERAMIC SOIC	(Still Air @ 0.5W)	231 C/W
	(500LF/Min Air flow @ 0.5W)	153 C/W
20 Ld LCC	(Still Air @ 0.5W)	90 C/W
	(500LF/Min Air flow @ 0.5W)	65 C/W
ThetaJC		
8 Ld DIP		21 C/W
8 Ld Metal Can Pkg		50 C/W
10 CERAMIC SOIC		24 C/W
20 Ld LCC		21 C/W
Storage Temperature Range		-65 C ≤ Ta ≤ 150 C
Maximum Junction Temperature		175 C
Lead Temperature (Soldering, 60 seconds)		300 C
Voltage at Strobe Pin		V+ -5V
Package Weight (Typical)		
8 Ld Metal Can		965mg
8 Ld Dip		1100mg
10 Ld CERAMIC SOIC		220mg
20 Ld LCC		TBD
ESD Rating (Note 4)		

(Absolute Maximum Ratings)(Continued)

(Note 1)

ESD Rating
(Note 4)

300V

- Note 1: Absolute Maximum Ratings indicate limits beyond which damage to the device may occur. Operating Ratings indicate conditions for which the device is functional, but do not guarantee specific performance limits. For guaranteed specifications and test conditions, see the Electrical Characteristics. The guaranteed specifications apply only for the test conditions listed. Some performance characteristics may degrade when the device is not operated under the listed test conditions.
- Note 2: This rating applies for $\pm 15V$ supplies. The positive input voltage limits is 30V above the negative supply. The negative input voltage limits is equal to the negative supply voltage or 30V below the positive supply, whichever is less.
- Note 3: The maximum power dissipation must be derated at elevated temperatures and is dictated by T_{jmax} (maximum junction temperature), θ_{JA} (package junction to ambient thermal resistance), and T_A (ambient temperature). The maximum allowable power dissipation at any temperature is $P_{dmax} = (T_{jmax} - T_A)/\theta_{JA}$ or the number given in the Absolute Maximum Ratings, whichever is lower.
- Note 4: Human body model, 1.5k Ohms in series with 100pF.

Recommended Operating Conditions

Supply Voltage

 $V_{CC} = \pm 15V_{dc}$

Operating Temperature Range

 $-55\text{ C} \leq T_a \leq +125\text{ C}$

Electrical Characteristics

DC PARAMETERS

(The following conditions apply to all the following parameters, unless otherwise specified.)
DC: $\pm V_{cc} = \pm 15V$, $V_{cm} = 0V$

SYMBOL	PARAMETER	CONDITIONS	NOTES	PIN-NAME	MIN	MAX	UNIT	SUB-GROUPS
Vio	Input Offset Voltage	Vin = 0V, Rs = 50 Ohms			-3	+3	mV	1
					-4	+4	mV	2, 3
		+Vcc = 29.5V, -Vcc = -0.5V, Vin = 0V, Vcm = -14.5V, Rs = 50 Ohms			-3	+3	mV	1
					-4	+4	mV	2, 3
		+Vcc = 2V, -Vcc = -28V, Vin = 0V, Vcm = +13V, Rs = 50 Ohms			-3	+3	mV	1
					-4	+4	mV	2, 3
Vio(R)	Raised Input Offset Voltage	Vin = 0V, Rs = 50 Ohms			-3	+3	mV	1
					-4.5	+4.5	mV	2, 3
		+Vcc = 29.5V, -Vcc = -0.5V, Vin = 0V, Vcm = -14.5V, Rs = 50 Ohms			-3	+3	mV	1
					-4.5	+4.5	mV	2, 3
		+Vcc = 2V, -Vcc = -28V, Vin = 0V, Vcm = +13V, Rs = 50 Ohms			-3	+3	mV	1
					-4.5	+4.5	mV	2, 3
Iio	Input Offset Current	Vin = 0V, Rs = 50K Ohms			-10	+10	nA	1, 2
					-20	+20	nA	3
		+Vcc = 29.5V, -Vcc = -0.5V, Vin = 0V, Vcm = -14.5V, Rs = 50K Ohms			-10	+10	nA	1, 2
					-20	+20	nA	3
		+Vcc = 2V, -Vcc = -28V, Vin = 0V, Vcm = +13V, Rs = 50K Ohms			-10	+10	nA	1, 2
					-20	+20	nA	3
Iio(R)	Raised Input Offset Current	Vin = 0V, Rs = 50K Ohms			-25	+25	nA	1, 2
					-50	+50	nA	3
Iib+	Input Bias Current	Vin = 0V, Rs = 50K Ohms			-100	0.1	nA	1, 2
					-150	0.1	nA	3
		+Vcc = 29.5V, -Vcc = -0.5V, Vin = 0V, Vcm = -14.5V, Rs = 50K Ohms			-150	0.1	nA	1, 2
					-200	0.1	nA	3
		+Vcc = 2V, -Vcc = -28V, Vin = 0V, Vcm = +13V, Rs = 50K Ohms			-150	0.1	nA	1, 2
					-200	0.1	nA	3

Electrical Characteristics

DC PARAMETERS (Continued)

(The following conditions apply to all the following parameters, unless otherwise specified.)
DC: $\pm V_{cc} = \pm 15V$, $V_{cm} = 0V$

SYMBOL	PARAMETER	CONDITIONS	NOTES	PIN-NAME	MIN	MAX	UNIT	SUB-GROUPS	
Iib-	Input Bias Current	Vin = 0V, Rs = 50K Ohms			-100	0.1	nA	1, 2	
					-150	0.1	nA	3	
		+Vcc = 29.5V, -Vcc = -0.5V, Vin = 0V, Vcm = -14.5V, Rs = 50K Ohms			-150	0.1	nA	1, 2	
					-200	0.1	nA	3	
		+Vcc = 2V, -Vcc = -28V, Vin = 0V, Vcm = +13V, Rs = 50K Ohms			-150	0.1	nA	1, 2	
					-200	0.1	nA	3	
Vo(STB)	Collector Output Voltage (ST)	Vin+ = Gnd, Vin- = 15V, Istb = -3mA, Rs = 50 Ohms	1		14		V	1, 2, 3	
CMR	Common Mode Rejection	-28V ≤ -Vcc ≤ -0.5V, Rs=50 Ohms, 2V ≤ +Vcc ≤ 29.5V, Rs=50 Ohms, -14.5V ≤ Vcm ≤ 13V, Rs=50 Ohms			80		dB	1, 2, 3	
Vol	Low Level Output Voltage	+Vcc = 4.5V, -Vcc = Gnd, Iout = 8mA, ±Vin = 0.71V, Vid = -6mV				0.4	V	1, 2, 3	
		+Vcc = 4.5V, -Vcc = Gnd, Iout = 8mA, ±Vin = -1.75V, Vid = -6mV				0.4	V	1, 2, 3	
		Iout = 50mA, ±Vin = 13V, Vid = -5mV				1.5		V	1, 2, 3
		Iout = 50mA, ±Vin = -14V, Vid = -5mV				1.5		V	1, 2, 3
Icex	Output Leakage Current	+Vcc = 18V, -Vcc = -18V, Vout = 32V			-1	10	nA	1	
					-1	500	nA	2	
Ii	Input Leakage Current	+Vcc = 18V, -Vcc = -18V, +Vin = +12V, -Vin = -17V	7		-5	500	nA	1, 2, 3	
		+Vcc = 18V, -Vcc = -18V, +Vin = -17V, -Vin = +12V	7		-5	500	nA	1, 2, 3	
Icc+	Power Supply Current					6	mA	1, 2	
						7	mA	3	
Icc-	Power Supply Current				-5		mA	1, 2	
					-6		mA	3	
Delta Vio/Delta T	Temperature Coefficient Input Offset Voltage	25 C ≤ T ≤ 125 C	8		-25	25	uV/	C 2	
		-55 C ≤ T ≤ 25 C	8		-25	25	uV/	C 3	
Delta Iio/Delta T	Temperature Coefficient Input Offset Current	25 C ≤ T ≤ 125 C	8		-100	100	pA/	C 2	
		-55 C ≤ T ≤ 25 C	8		-200	200	pA/	C 3	

Electrical Characteristics

DC PARAMETERS (Continued)

(The following conditions apply to all the following parameters, unless otherwise specified.)
DC: $\pm V_{CC} = \pm 15V$, $V_{cm} = 0V$

SYMBOL	PARAMETER	CONDITIONS	NOTES	PIN-NAME	MIN	MAX	UNIT	SUB-GROUPS
Ios	Short Circuit Current	Vout = 5V, t ≤ 10mS, Vin- = 0.1V, Vin+ = 0V	3, 5			200	mA	1
			3, 5			150	mA	2
			3, 5			250	mA	3
Vio(adj)+	Input Offset Voltage (Adjustment)	Vout = 0V, Vin = 0V, Rs = 50 Ohms	3		5		mV	1
Vio(adj)-	Input Offset Voltage (Adjustment)	Vout = 0V, Vin = 0V, Rs = 50 Ohms	3			-5	mV	1
Ave+	Voltage Gain (Emitter)	Rl = 600 Ohms	3, 6		10		V/mV	4
			3, 6		8		V/mV	5, 6
Ave-	Voltage Gain (Emitter)	Rl = 600 Ohms	3, 6		10		V/mV	4
			3, 6		8		V/mV	5, 6

AC PARAMETERS

(The following conditions apply to all the following parameters, unless otherwise specified.)
AC: $\pm V_{CC} = \pm 15V$, $V_{cm} = 0$

trLHC	Response Time (Collector Output)	Vod(Overdrive) = -5mV, Cl = 50pF, Vin = -100mV	4, 8			300	nS	7, 8B
			4, 8			640	nS	8A
trHLC	Response Time (Collector Output)	Vod(Overdrive) = 5mV, Cl = 50pF, Vin = 100mV	4, 8			300	nS	7, 8B
			4, 8			500	nS	8A

Note 1: Istb = -2mA at -55 C.

Note 2: Calculated parameter.

Note 3: Use DC tape for Ios and Vio(adj), Ave+ and Ave- as indicated in TAPE NAME section of this JRETS.

Note 4: Uses AC tape and hardware.

Note 5: Actual min. limit used is 5mA due to test setup.

Note 6: Datalog reading in K = V/mV.

Note 7: Vid is voltage difference between inputs.

Note 8: Group A sample ONLY

Graphics and Diagrams

GRAPHICS#	DESCRIPTION
05172HRB2	METAL CAN (H), TO-99, 8LD .200 DIA P.C. (B/I CKT)
05174HRC2	CERPACK (W), 10 LEAD (B/I CKT)
05284HRC2	METAL CAN (H), TO-99, 3LD .200 DIA P.C. (B/I CKT)
05445HRC1	CERDIP (J), 8 LEAD (B/I CKT)
05652HRA2	CERDIP (J), 8 LEAD (B/I CKT)
05815HRA3	LCC (E), TYPE C, 20 TERMINAL (B/I CKT)
09569HRC2	CERPACK (W), 10 LEAD (B/I CKT)
E20ARE	LCC (E), TYPE C, 20 TERMINAL(P/P DWG)
H08CRF	METAL CAN (H), TO-99, 8LD, .200 DIA P.C. (P/P DWG)
J08ARL	CERDIP (J), 8 LEAD (P/P DWG)
P000264A	METAL CAN (H), 8 LEAD (PINOUT)
P000265A	CERDIP (J), 8 LEAD (PINOUT)
P000314B	LCC (E), 20 LEAD (PINOUT)
P000373A	CERAMIC SOIC (WG), 10 LEAD (PINOUT)
WG10ARC	CERAMIC SOIC (WG), 10 LEAD (P/P DWG)

See attached graphics following this page.

REVISIONS			
LTR	DESCRIPTION	E.C.N.	DATE
E	REVISE AND REDRAW	10005	02/10/94 DEG/

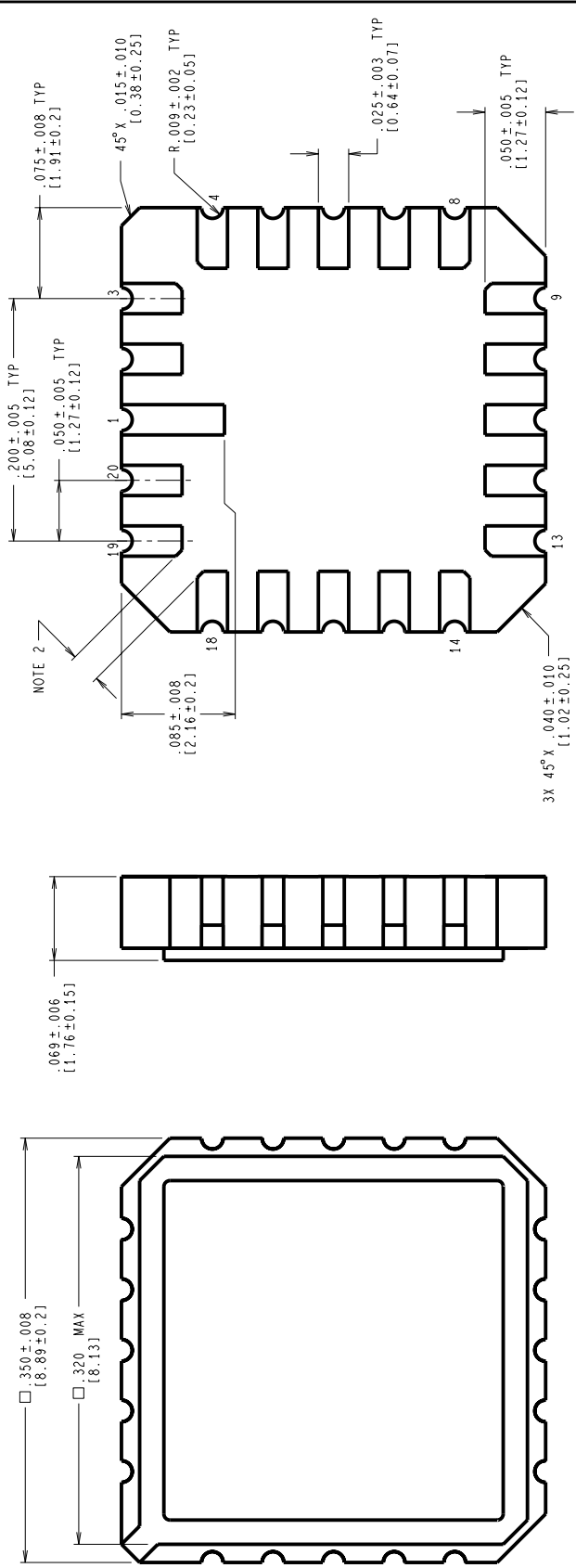

- NOTES: UNLESS OTHERWISE SPECIFIED.
- LEAD FINISH TO BE ONE OF THE FOLLOWING:
 - 50 MICRONS/12.7 MICROMETERS MINIMUM GOLD PLATING OVER 50-350 MICRONS/1.27-8.89 MICROMETERS NICKEL.
 - SOLDER DIP. SOLDER THICKNESS PER LATEST REVISION OF MIL-STD-1835.
 - CORNER PADS MAY HAVE A 45° X 0.20 IN/ 0.51 mm MAXIMUM CHAMFER TO ACCOMPLISH THE 0.15 IN/ 0.38 mm DIMENSION.
 - REFERENCE JEDEC REGISTRATION MS-004, VARIATION CB, DATED 7/90.

CONTROLLING DIMENSION IS INCH
VALUES IN [] ARE MILLIMETERS

MIL/AERO
CONFIGURATION CONTROL

APPROVALS		DATE
DRN: <i>Deane Gedy</i>		02/10/94
DFTG: CHK.		
ENGR: CHK.		
APPROVAL		

NATIONAL SEMICONDUCTOR CORPORATION 2300 Semiconductor Drive, Santa Clara, Ca. 95052-8090	
LEADLESS CHIP CARRIER, TYPE C, 20 TERMINAL	
SCALE	SIZE
N/A	C
DRAWING NUMBER	
MKT-E20A	
REV	E

PROJECTION	DO NOT SCALE DRAWING
	SHEET 1 of 1

REVISIONS

LTR	DESCRIPTION	E.C. N.	DATE	BY/APP'D
F	REVISE & REDRAW PER CURRENT STANDARD; UPDATE MIL/AERO STAMP & TITLE.	11002	06/22/95	MS/

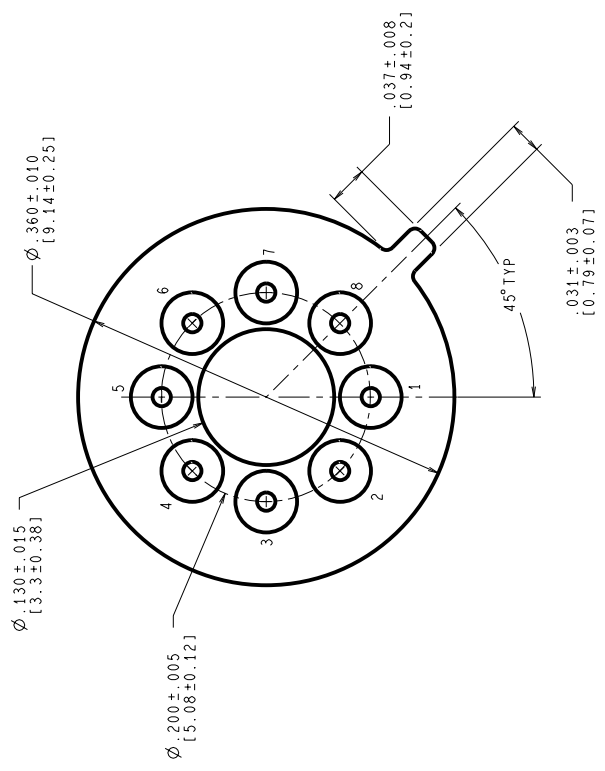
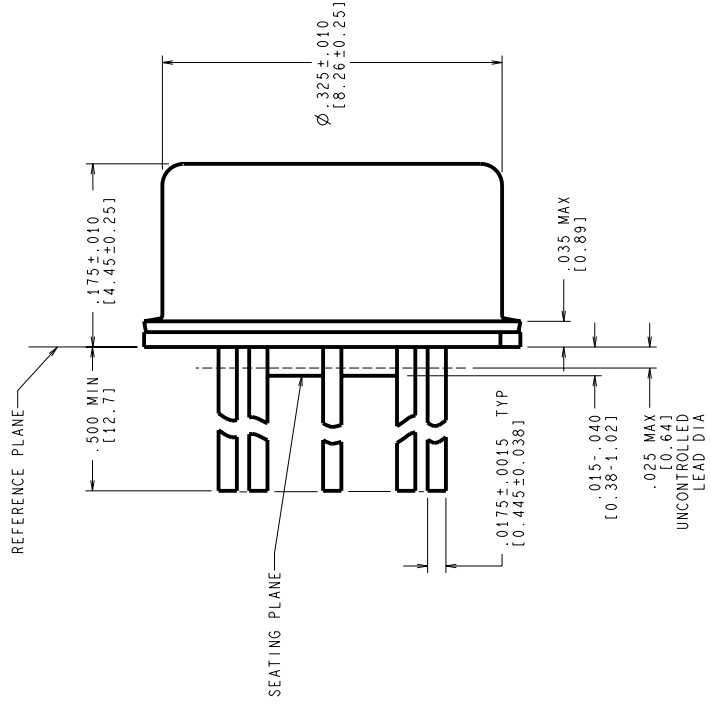

CONTROLLING DIMENSION IS INCH
VALUES IN [] ARE MILLIMETERS

MIL-I-38535
CONFIGURATION CONTROL

NOTES: UNLESS OTHERWISE SPECIFIED

- LEADS TO BE LOCATED WITHIN .007 IN/ 0.18 mm OF THEIR TRUE POSITIONS RELATIVE TO A MAXIMUM WIDTH TAB.
- STANDARD METAL CAN TYPE: SOLID BASE WITH CERAMIC STANDOFF.
- APPLIES TO MIL-AERO AND LINEAR PRODUCTS.
- REFERENCE JEDEC REGISTRATION TO-99, JEDEC PUBLICATION No. 95.

APPROVALS	DATE
DRN: MARTA SUCHY	06/22/95
DWG. CHK.	
ENGR. CHK.	

National Semiconductor 2800 Semiconductor Dr., Santa Clara, CA 95052-8090	
METAL CAN, TO-99, 8 LEAD, .200 DIA P.C.	
SCALE	N/A
SIZE	C
DRAWING NUMBER	MKT-H08C
REV	F

PROJECTION	
DO NOT SCALE DRAWING	
SHEET 1 of 1	

REV I S I O N S

LTR	DESCRIPTION	E.C.N.	DATE	BY/APP'D
L	REVISE PER CURRENT STD; REDRAW	10002	09/21/93	TL/

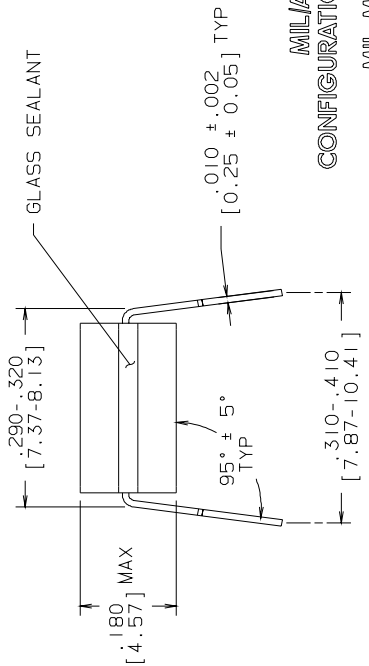
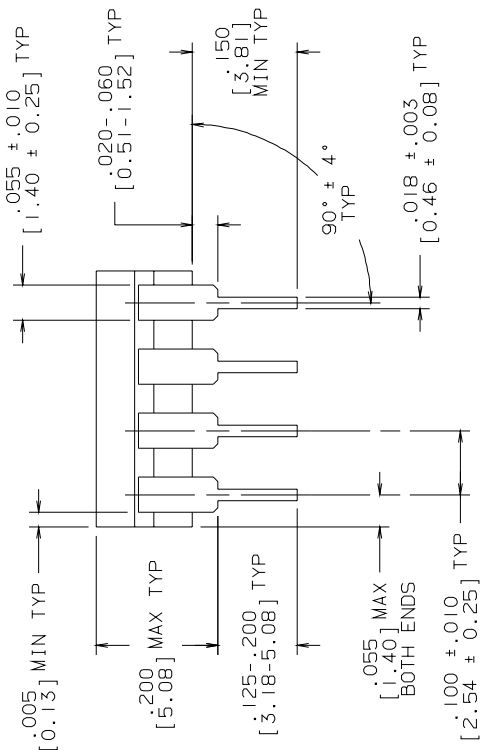
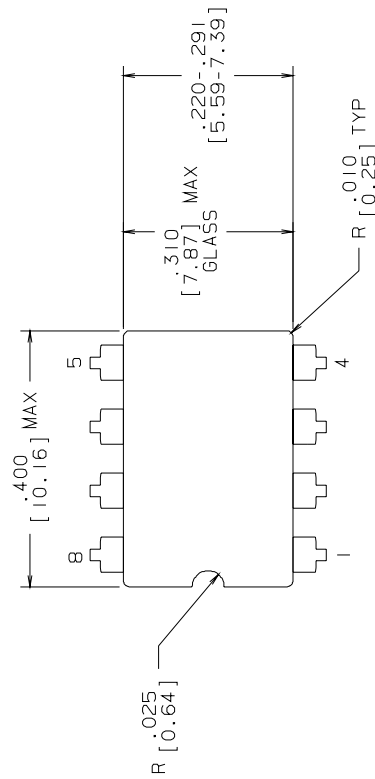

MILAERO
CONFIGURATION CONTROL
MIL-M-38510
CONFIGURATION CONTROL

CONTROLLING DIMENSION: INCH			
APPROVALS	DATE		
DRAWN <i>T. LEQUANG</i>	09/21/93		
DFTG. CHK.			
ENGR. CHK.			
APPROVAL			
SCALE	SIZE	DRAWING NUMBER	REV
N/A	B	MKT-J08A	L
DO NOT SCALE DRAWING		SHEET	OF
		1	1

NATIONAL SEMICONDUCTOR CORPORATION
2900 Semiconductor Drive, Santa Clara, CA 95052-8090

CERDIP (J),
8 LEAD

NOTES: UNLESS OTHERWISE SPECIFIED

- LEAD FINISH TO BE 200 MICROMETERS / 5.08 MICROMETERS MINIMUM SOLDER MEASURED AT THE CREST OF THE MAJOR FLATS.
- JEDEC REGISTRATION MO-036, VARIATION AA, DATED 04/1981.

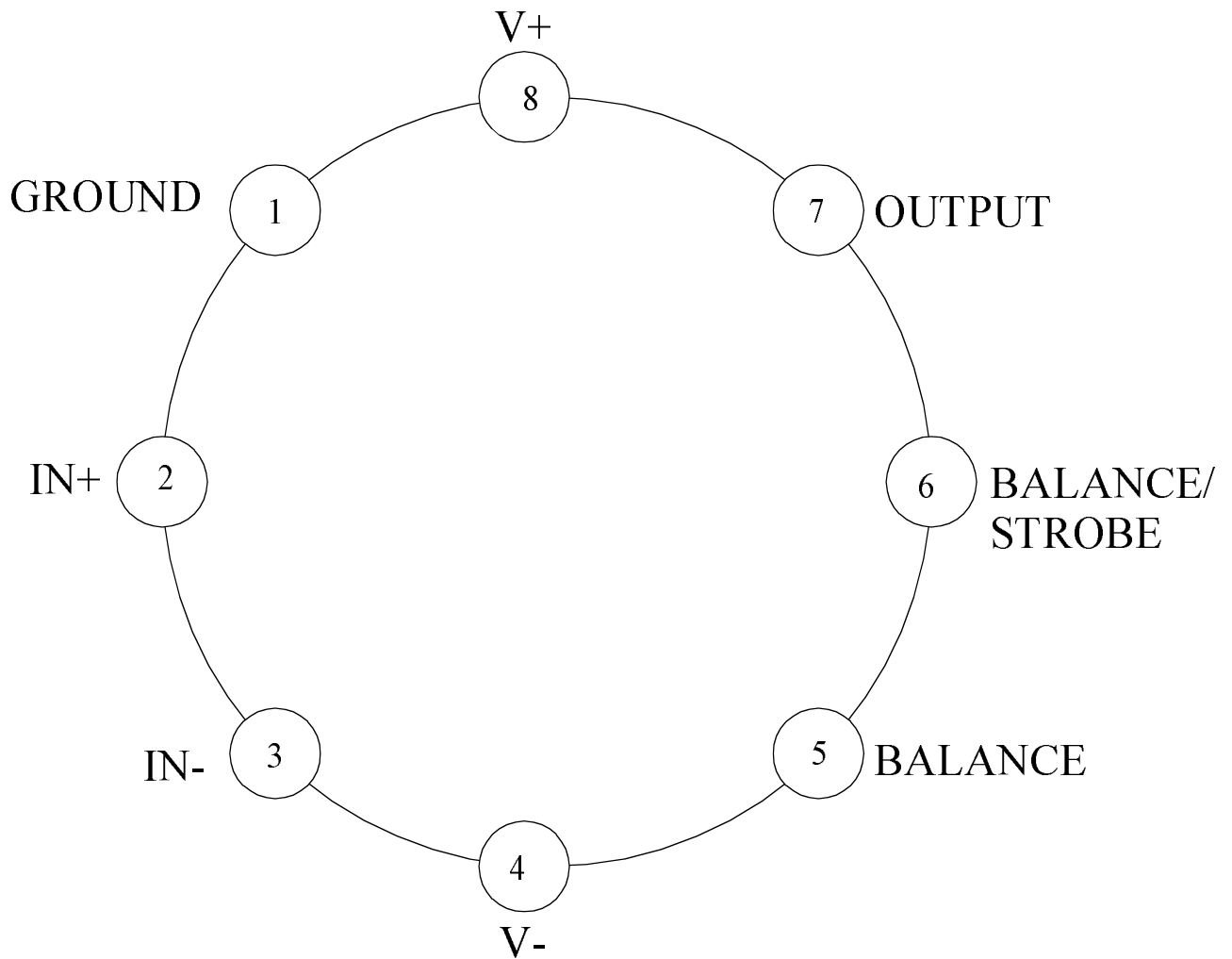

LM111H
8 - PIN METAL CAN
CONNECTION DIAGRAM
TOP VIEW
P000264A



National Semiconductor™
MIL/AEROSPACE OPERATIONS
2900 SEMICONDUCTOR DRIVE
SANTA CLARA, CA 95050

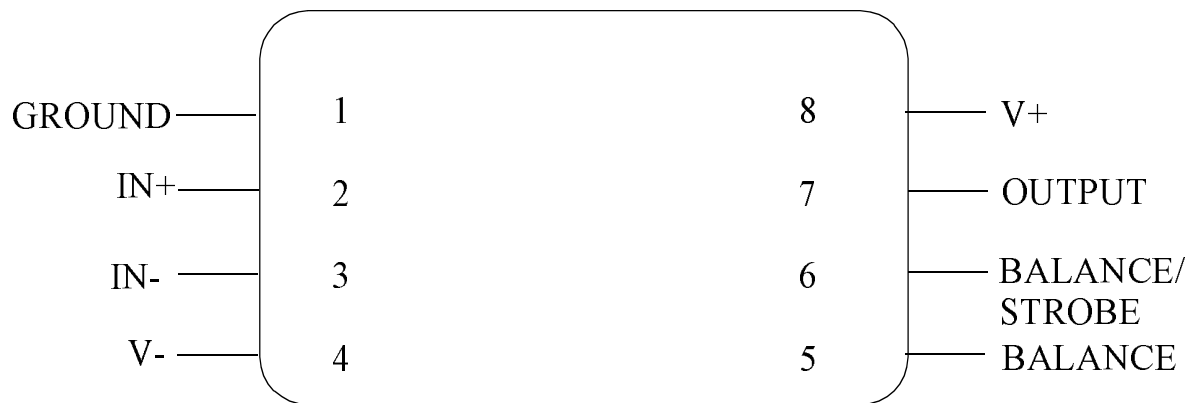

LM111J-8
8 - LEAD DIP
CONNECTION DIAGRAM
TOP VIEW
P000265A



National Semiconductor™
MIL/AEROSPACE OPERATIONS
2900 SEMICONDUCTOR DRIVE
SANTA CLARA, CA 95050

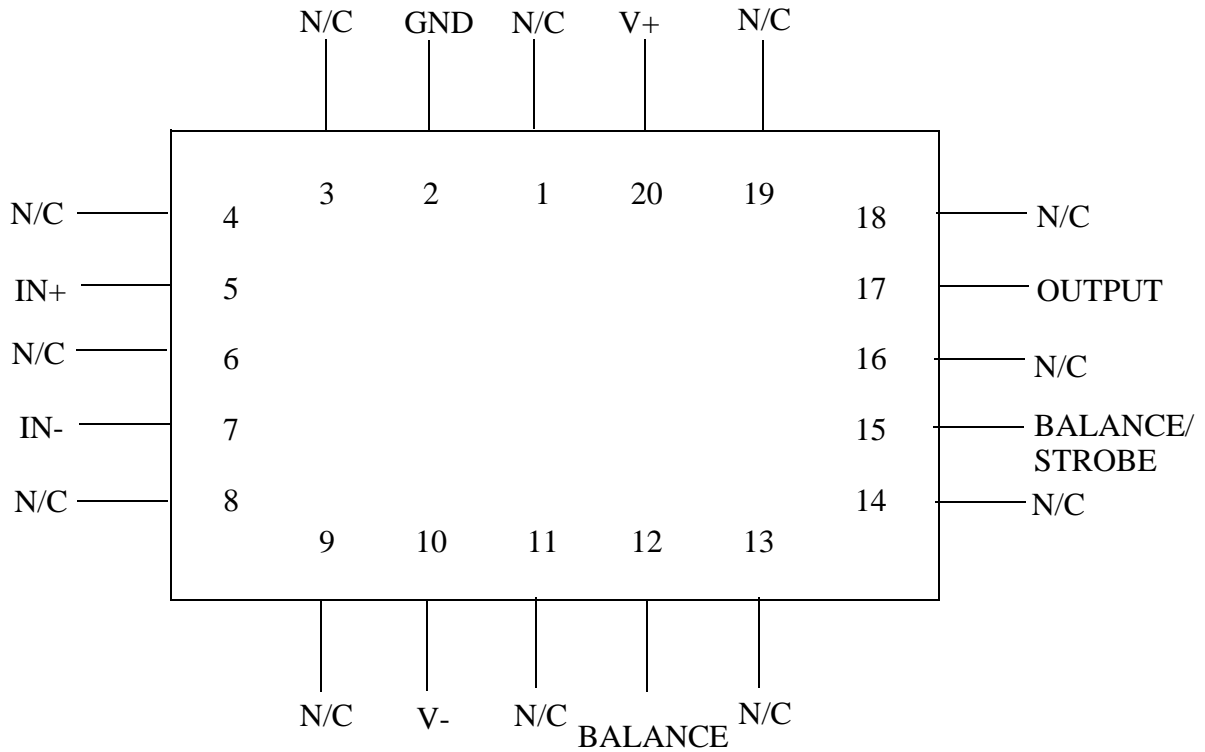

LM111E
20 - LEAD LCC
CONNECTION DIAGRAM
TOP VIEW
P000314B

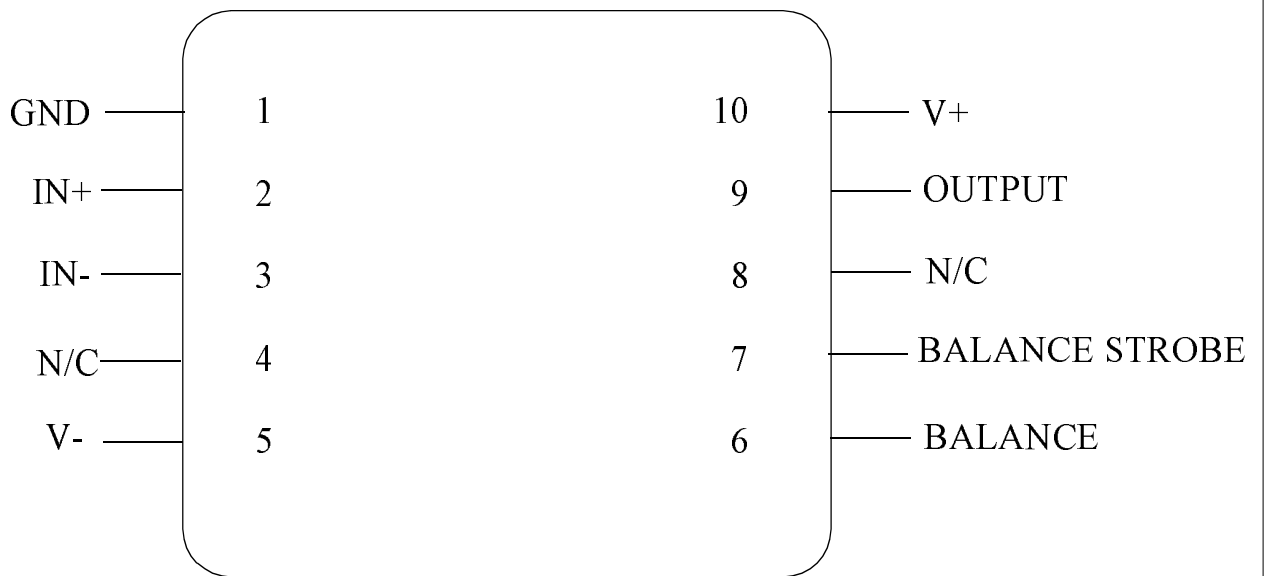

LM111WG
10 - LEAD CERAMIC SOIC
CONNECTION DIAGRAM
TOP VIEW
P000373A



National Semiconductor™

MIL/AEROSPACE OPERATIONS
2900 SEMICONDUCTOR DRIVE
SANTA CLARA, CA 95050

REVISIONS

LTR	DESCRIPTION	E.C.N.	DATE	BY/APP'D
A	RELEASE TO DOCUMENT CONTROL	11374	02/29/1996	MS/KH
B	LD PITCH TOL WAS ±.005; CHANGE LD RADIUS TO REF DIM; REMOVE THE OTHER R.006±.002 DIM. .040±.003 WAS .037±.003	11441	04/19/1996	MS/KH
C	R .015(0.38) WAS R .006(0.15)	11838	10/08/1997	TL/

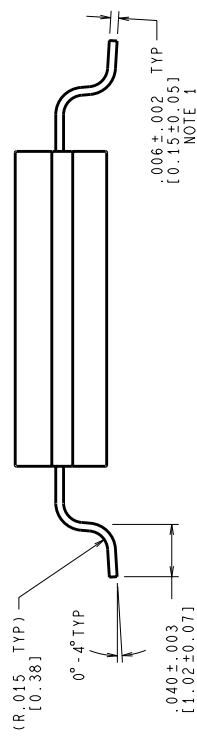
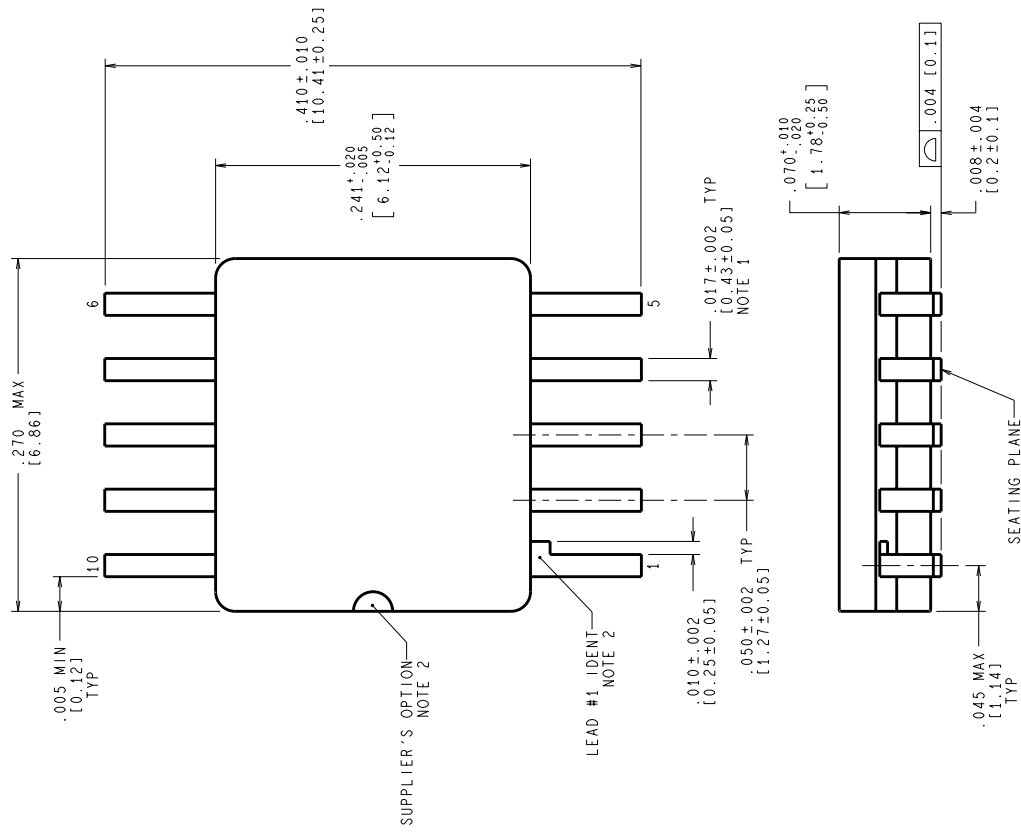

CONTROLLING DIMENSION IS INCH
VALUES IN | ARE MILLIMETERS

MIL-PRF-38535
CONFIGURATION CONTROL

NOTES: UNLESS OTHERWISE SPECIFIED

- LEAD FINISH: SOLDER DIPPED WITH Sn60 OR Sn63 SOLDER CONFORMING TO MIL-PRF-38535 TO A MINIMUM THICKNESS OF 200 MICRONS/ 5.08 MICROMETERS. SOLDER MAY BE APPLIED OVER LEAD BASIS METAL OR Sn PLATE. MAXIMUM LIMIT MAY BE INCREASED BY .003 IN/ 0.08mm AFTER LEAD FINISH APPLIED.
- LEAD 1 IDENTIFICATION SHALL BE:
 - A NOTCH OR OTHER MARK WITHIN THIS AREA
 - A TAB ON LEAD 1, EITHER SIDE
- NO JEDEC REGISTRATION AS OF FEBRUARY 1996.

APPROVALS	DATE	SCALE	SIZE	DRAWING NUMBER	REV
DRN: <i>MARYA SUCHY</i>	02/29/96	N/A	C	(SC)MKT-WG10A	C
DATE: 02/29/96					
ENGR. CHK.					
National Semiconductor 2800 Semiconductor Dr., Santa Clara, CA 95052-8090					
CERPACK, 10 LEAD, GULL WING					
DO NOT SCALE DRAWING SHEET 1 of 1					

Revision History

Rev	ECN #	Rel Date	Originator	Changes
0A0	M0003786	04/20/01	Rose Malone	Initial MDS Release: MDLM111-X, Rev. 0A0
0B0	M0003794	04/20/01	Rose Malone	Update MDS: MDLM111-X, Rev. 0A0 to MDLM111-X, Rev. 0B0. Added Note 8 to DC and AC Electrical Sections for the following parameters Delta Vio/Delta T, Delta Iio/Delta T, trLHC and trHLC