



CATV OUT-OF-BAND TUNER

UPC3220GR

FEATURES

- **LOW DISTORTION:** IIP3 = +1 dBm TYP.
- **WIDE AGC DYNAMIC RANGE:** GCR_{total} = 46 dB TYP.
- **LOW NOISE FIGURE:** 7 dB TYP
- **HIGH GAIN:** 71 dB TYP
- **ON CHIP VIDEO AMPLIFIER**
- **SINGLE SUPPLY VOLTAGE :** 5 V
- **PACKAGED IN 16-PIN SSOP SUITABLE FOR HIGH-DENSITY SURFACE MOUNTING**

DESCRIPTION

The μ PC3220GR is silicon monolithic IC designed for use as the out-of-band tuner for digital CATV applications. This IC consists of AGC amplifier, low distortion mixer, and video amplifier. The package is 16-pin SSOP (Shrink Small Outline Package) suitable for surface mount. This IC is manufactured using our 10 GHz fT NESAT II AL silicon bipolar process. This process uses silicon nitride passivation film. This material can protect chip surface from external pollution and prevent corrosion/migration. Thus, this IC has excellent performance, uniformity and reliability. NEC's stringent quality assurance and test procedures ensure the highest reliability and performance.

INTERNAL BLOCK DIAGRAM

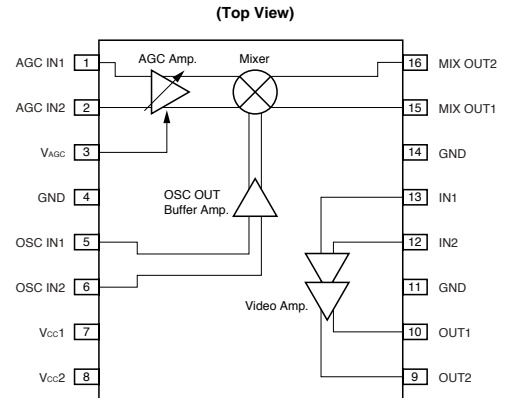

APPLICATION

- **DIGITAL CABLE SETTOP BOXES**
- **HDTV RECEIVERS**

ELECTRICAL CHARACTERISTICS (T_A = 25°C, V_{CC} = 5 V, unless otherwise specified)

PART NUMBER			UPC3220GR		
SYMBOL	PARAMETERS AND CONDITIONS	UNIT	MIN.	TYP.	MAX.
I _{CCTOTAL}	Total Circuit Current ¹ , No input signal, V _{CC1} = V _{CC2} = 5 V	mA	33	42	53.5
I _{CC1}	AGC/Mixer Circuit Current ¹¹ , No input signal, V _{CC1} = 5 V	mA	15	20	25.5
I _{CC2}	Video Amplifier Circuit Current ²¹ , No input signal, V _{CC2} = 5 V	mA	18.0	22.0	28
V _{AGC} (H)	AGC Voltage High Level ¹ , at Maximum gain	V	3.0	–	V _{CC}
V _{AGC} (L)	AGC Voltage Low Level ¹ , at Minimum gain	V	0	–	0.5
RF Characteristics: AGC Amplifier Block (f _{RF} = 100 MHz, f _{LO} = 136 MHz, P _{LO} = -15 dBm, f _{IF} = 36 MHz, Z _S = 50 Ω, Z _L = 1 kΩ)					
f _{RF}	RF Input Frequency Range ¹	MHz	30	–	250
f _{IF}	IF Output Frequency Range ¹	MHz	0.1	–	150
GCR _{AGC}	AGC Dynamic Range ¹ , V _{AGC} = 0.5 to 3.0 V	dB	–	46	–
RF Characteristics: Video Amplifier Block (f = 36 MHz, Z _S = 50 Ω, Z _L = 1 kΩ)					
V _{OMAX} ²	Maximum Output Voltage ² , Pin = -25 dBm	Vp-p	2.95	3.90	–
RF Characteristics: Total Block (f _{RF} = 100 MHz, f _{LO} = 136 MHz, P _{LO} = -15 dBm, f _{IF} = 36 MHz, Z _S = 50 Ω, Z _L = 1 kΩ)					
CG _{MAX}	Maximum Conversion Gain ³ , V _{AGC} = 3.0 V, Pin = -70 dBm	dB	65.5	71	73.5
CG _{MIN}	Minimum Conversion Gain ³ , V _{AGC} = 0.5 V, Pin = -40 dBm	dB	18	25	31.5
GCR _{total}	Total Dynamic Range ³ , V _{AGC} = 0.5 to 3.0 V	dB	34	46	–
V _{OMAX}	Maximum Output Voltage ³ , V _{AGC} = 3.0 V, Pin = -45 dBm	Vp-p	2.95	3.90	–
NF _{total}	Noise Figure ⁴ , DSB, V _{AGC} = 3.0 V (at Maximum gain)	dB	–	7.0	8.5

Notes:

1. By Measurement Circuit 1
2. By Measurement Circuit 4
3. By Measurement Circuit 6
4. By Measurement Circuit 7

STANDARD CHARACTERISTICS ($T_A = +25^\circ\text{C}$, $V_{CC1} = 5\text{ V}$, $Z_S = 50\ \Omega$)

SYMBOL	PARAMETERS AND CONDITIONS	UNIT	REFERENCE VALUE
AGC Amplifier+Mixer Block ($f_{RF} = 84\text{ MHz}$, $f_{LO} = 120\text{ MHz}$, $P_{LO} = -15\text{ dBm}$, $f_{IF} = 36\text{ MHz}$, $Z_S = 50\ \Omega$, $Z_L = 1\text{ k}\Omega$)			
CG _{MAX}	Maximum Conversion Gain, $V_{AGC} = 3.0\text{ V}$, $P_{in} = -45\text{ dBm}^1$	dB	34.0
CG _{MIN}	Minimum Conversion Gain, $V_{AGC} = 0.5\text{ V}$, $P_{in} = -45\text{ dBm}^1$	dB	-12.0
NF	Noise Figure, DSB, $V_{AGC} = 3.0\text{ V}$ (at Maximum gain) ²	dB	7.0
IIP ₃	Input 3rd Order Distortion Intercept Point, $V_{AGC} = 0.5\text{ V}$ (at Minimum gain) ¹	dBm	+1.0
V _{oclip}	Maximum Output Voltage, $V_{AGC} = 3.0\text{ V}$, $P_{in} = -20\text{ dBm}^1$	V _{p-p}	0.68
Z _{RF}	RF Input Impedance, $V_{AGC} = 3.0\text{ V}$, $f = 84\text{ MHz}^3$	k Ω	560 - j1050
Z _{LO}	LO Input Impedance, $V_{AGC} = 3.0\text{ V}$, $f = 120\text{ MHz}^3$	k Ω	307 - j837
Z _{IF}	IF Output Impedance, $V_{AGC} = 3.0\text{ V}$, $f = 36\text{ MHz}^3$	Ω	40.7 + j1.5
Video Amplifier Block ($f = 36\text{ MHz}$, $Z_S = 50\ \Omega$, $Z_L = 1\text{ k}\Omega$)			
f _{BW}	Frequency Range, $P_{in} = -55\text{ dBm}$, -1 dB down ⁴	MHz	53
G _{diff}	Differential Gain, $P_{in} = -55\text{ dBm}^4$	dB	51
Z _{in}	Input Impedance, $f = 36\text{ MHz}^5$	k Ω	620 - j808
Z _{out}	Output Impedance, $f = 36\text{ MHz}^5$	Ω	18 + j12
Total Block ($f_{LO} = 120\text{ MHz}$, $P_{LO} = -15\text{ dBm}$, $f_{IF} = 36\text{ MHz}$, $Z_S = 50\ \Omega$, $Z_L = 1\text{ k}\Omega$)			
IIP _{3total}	Input 3rd Order Distortion Intercept Point, $V_{AGC} = 0.5\text{ V}$ (at Minimum gain) ⁶	dBm	+1.0
IM _{3total}	3rd Order Intermodulation Distortion, $V_{out} = 0.7\text{ V}_{p-p} \times 2\text{ tone}$, $P_{in} -50\text{ dBm/tone}^6$	dBc	53

Notes:

1. By measurement circuit 1
2. By measurement circuit 2
3. By measurement circuit 3
4. By measurement circuit 4
5. By measurement circuit 5
6. By measurement circuit 6

ABSOLUTE MAXIMUM RATINGS¹ ($T_A = 25^\circ\text{C}$)

SYMBOL	PARAMETERS	UNIT	RATINGS
V _{CC}	Supply Voltage, $T_A = +25^\circ\text{C}$	V	6.0
P _D	Power Dissipation, $T_A = +85^\circ\text{C}$	mW	433
T _A	Operating Ambient Temperature	$^\circ\text{C}$	-40 to +85
T _{stg}	Storage Temperature	$^\circ\text{C}$	-55 to +150

RECOMMENDED OPERATING CONDITIONS

SYMBOL	PARAMETERS	UNIT	MIN.	TYP.	MAX.
V _{CC}	Supply Voltage	V	4.5	5.0	5.5
T _A	Operating Ambient Temperature, $V_{CC} = 4.5\text{ to }5.5\text{ V}$	$^\circ\text{C}$	-40	+25	+85
V _{AGC}	Input Power	V	0	-	V _{CC}

PIN FUNCTIONS

Pin No.	Symbol	Pin Voltage	Function and Application	Internal Equivalent Circuit
1	RF IN1	1.46	Input Signal of IF signal. 1 pin is the same phase and 2 pin is opposite phase at balance input. In case of single input, 1pin or 2pin should be grounded through capacitor (ex. 10 nF).	
2	RF IN2	1.46		
3	VAGC	0 to 3.5	Automatic gain control pin. This pin's bias governs the AGC output level. Minimum gain at VAGC = 0V Maximum gain at VAGC = 3.5 V	
4	GND	0.0	Ground pin. Must be connected to the system ground with minimum inductance. Ground pattern on the board should be formed as wide as possible.	
5	OSC IN1	2.6	Input pin of Oscillator signal. 5pin is same phase and 6pin is opposite phase as balance input. In case of single input, 5pin or 6 pin should be grounded through capacitor (ex. 10 nF).	
6	OSC IN2	2.6		
7	VCC1	5.0	Power supply pin of IF down converter block. Must be connected bypass capacitor to minimize ground impedance.	
8	VCC2	5.0	Power supply pin of video amplifier Must be connected bypass capacitor to minimize ground impedance.	

PIN FUNCTIONS

Pin No.	Symbol	Pin Voltage	Function and Application	Internal Equivalent Circuit
9	AMP OUT2	2.5	Output pin of video amplifier. OUT1 and IN1 are same phase. OUT2 and IN2 are same phase.	
10	AMP OUT1	2.5		
11	GND	0.0	Ground pin. Must be connected to the system ground with minimum inductance. Ground pattern on the board should be formed as wide as possible.	
12	AMP IN2	1.45	Signal input pin of video amplifier. This pin is high impedance.	
13	AMP IN1	1.45		
14	GND	0.0	Ground pin. Must be connected to the system ground with minimum inductance. Ground pattern on the board should be formed as wide as possible.	
15	MIX OUT1	3.7	Output pin of mixer. This output pin features low-impedance because of its emitter-follower output port.	
16	MIXOUT2	3.7		

INTERNAL BLOCK DIAGRAM AND PIN LAYOUT

(Top View)

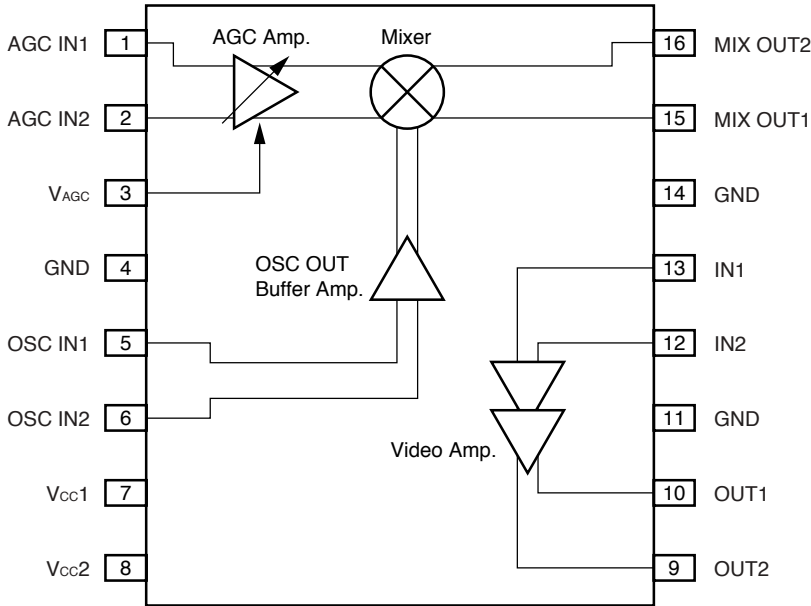

MEASUREMENT CIRCUIT 1

IM3 MEASUREMENT CIRCUIT ON THE AGC/DOWNCONVERTER

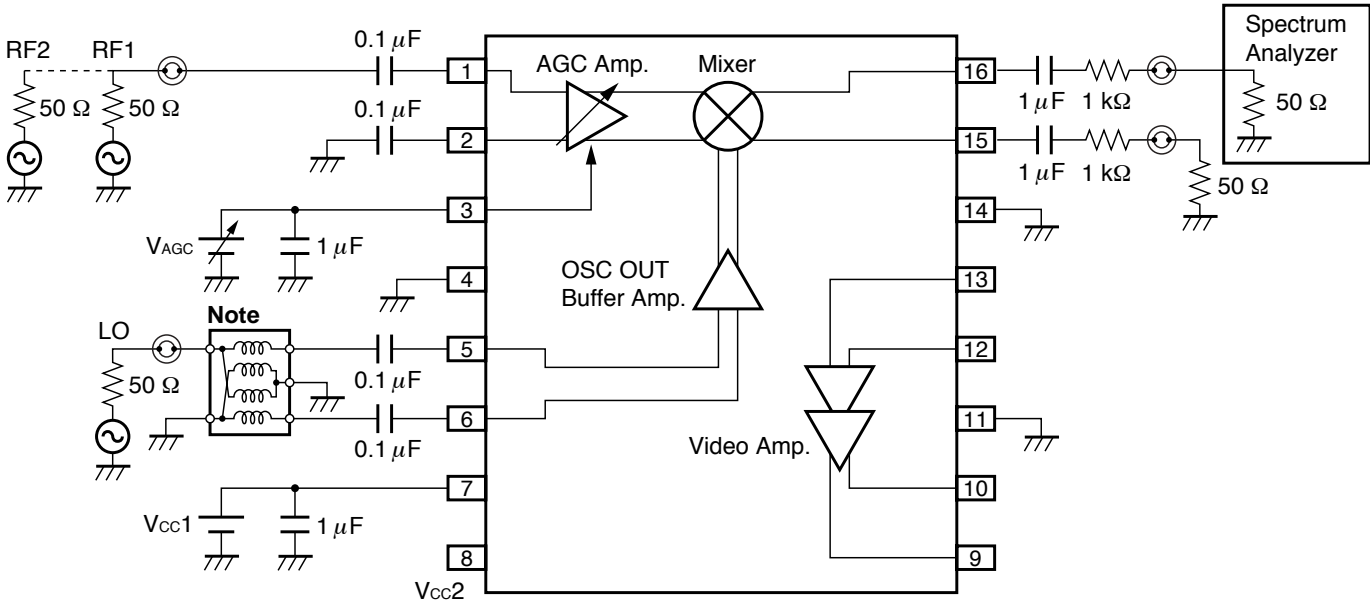

Note: Balun Transformer : TOKO 617DB-1010 B4F (Double balanced type)

MEASUREMENT CIRCUIT 2

NOISE FIGURE MEASUREMENT ON DOWNCONVERTER

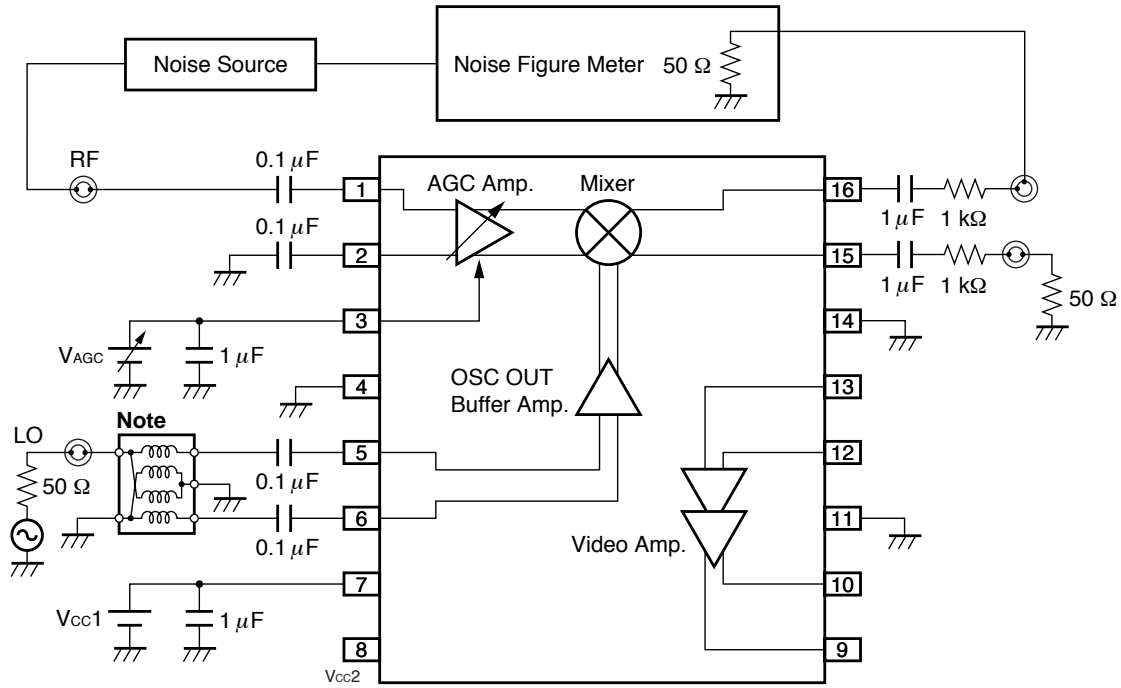

Note: Balun Transformer : TOKO 617DB-1010 B4F (Double balanced type)

MEASUREMENT CIRCUIT 3

S-PARAMETER CHARACTERIZATION OF THE DOWNCONVERTER

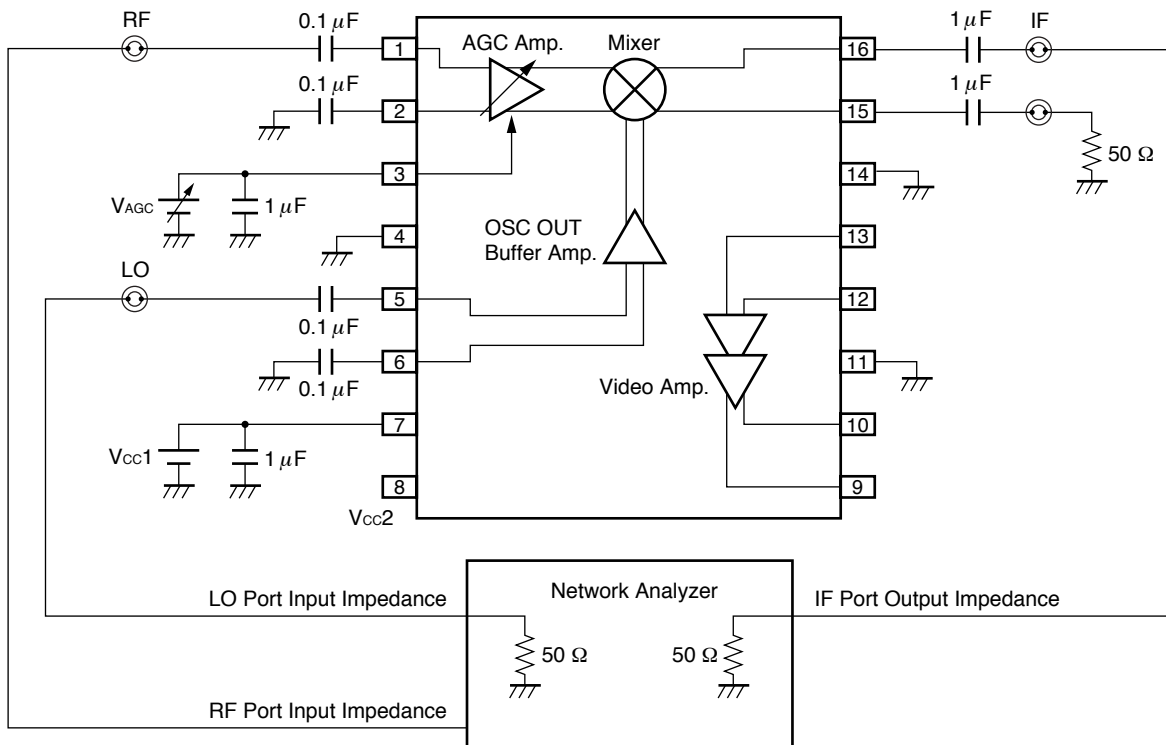

MEASUREMENT CIRCUIT 4
CHARACTERIZATION OF THE VIDEO AMPLIFIER

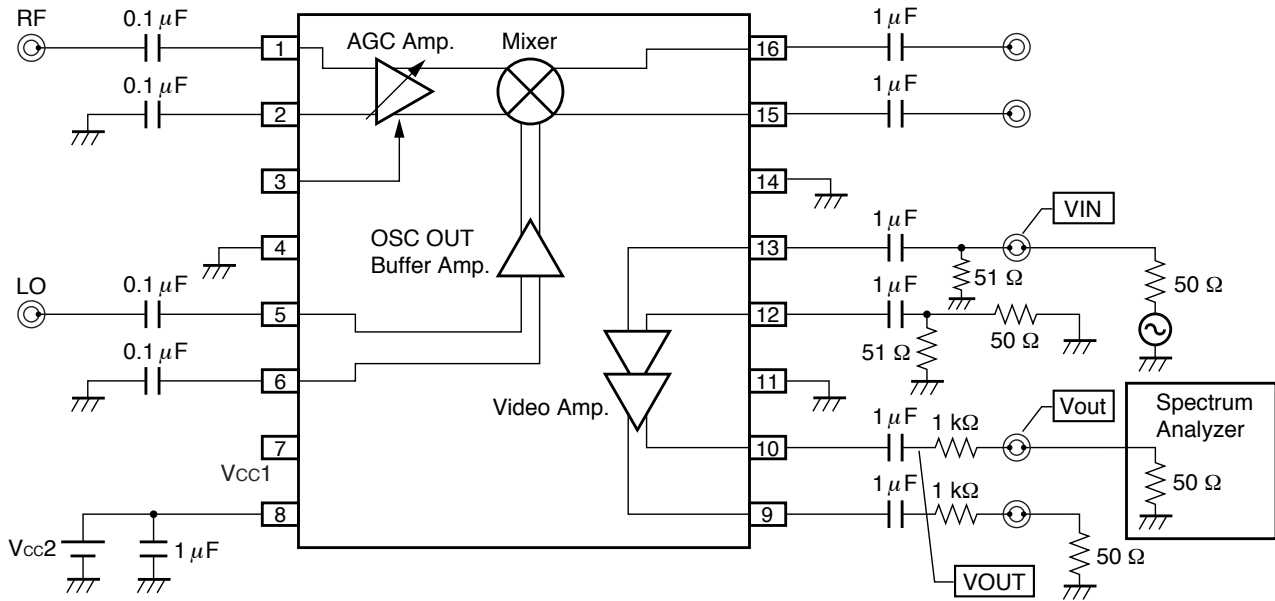

Voltage Gain(Single Ended) = $20\text{Log}(V_{OUT}/V_{IN})$ (dB)
 Differential Gain(Differential-out) = $20\text{Log}(2 \cdot V_{OUT}/V_{IN})$ (dB)

$V_{OUT} = V_{out}(\text{Measured Value}) \times (1050/50)$

MEASUREMENT CIRCUIT 5
S-PARAMETERS CHARACTERIZATION OF THE VIDEO AMPLIFIER

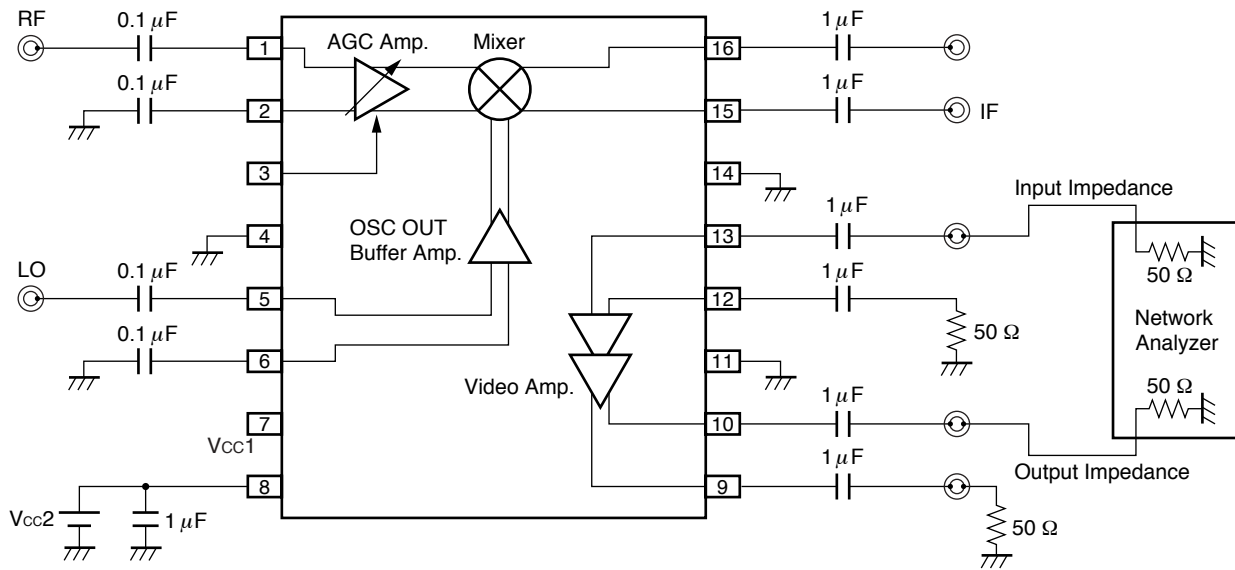

MEASUREMENT CIRCUIT 6 COMPLETE OUT-OF-BAND TUNER CHARACTERIZATION

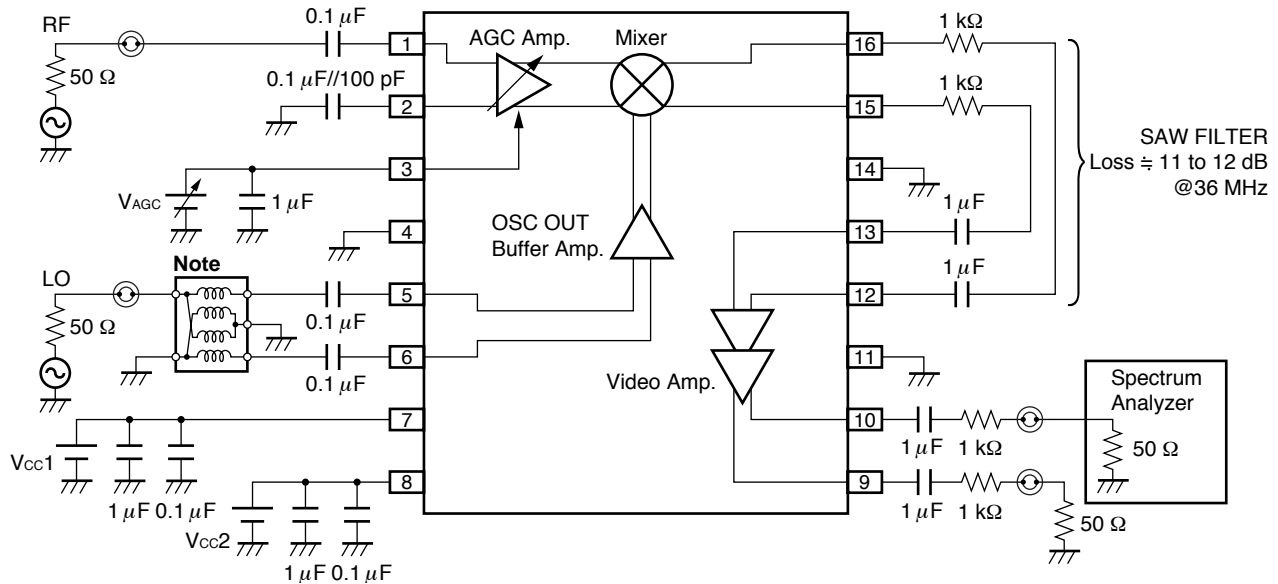

Note: Balun Transformer : TOKO 617DB-1010 B4F (Double balanced type)

MEASUREMENT CIRCUIT 7 NOISE FIGURE MEASUREMENT ON TOTAL OUT-OF-BAND TUNER

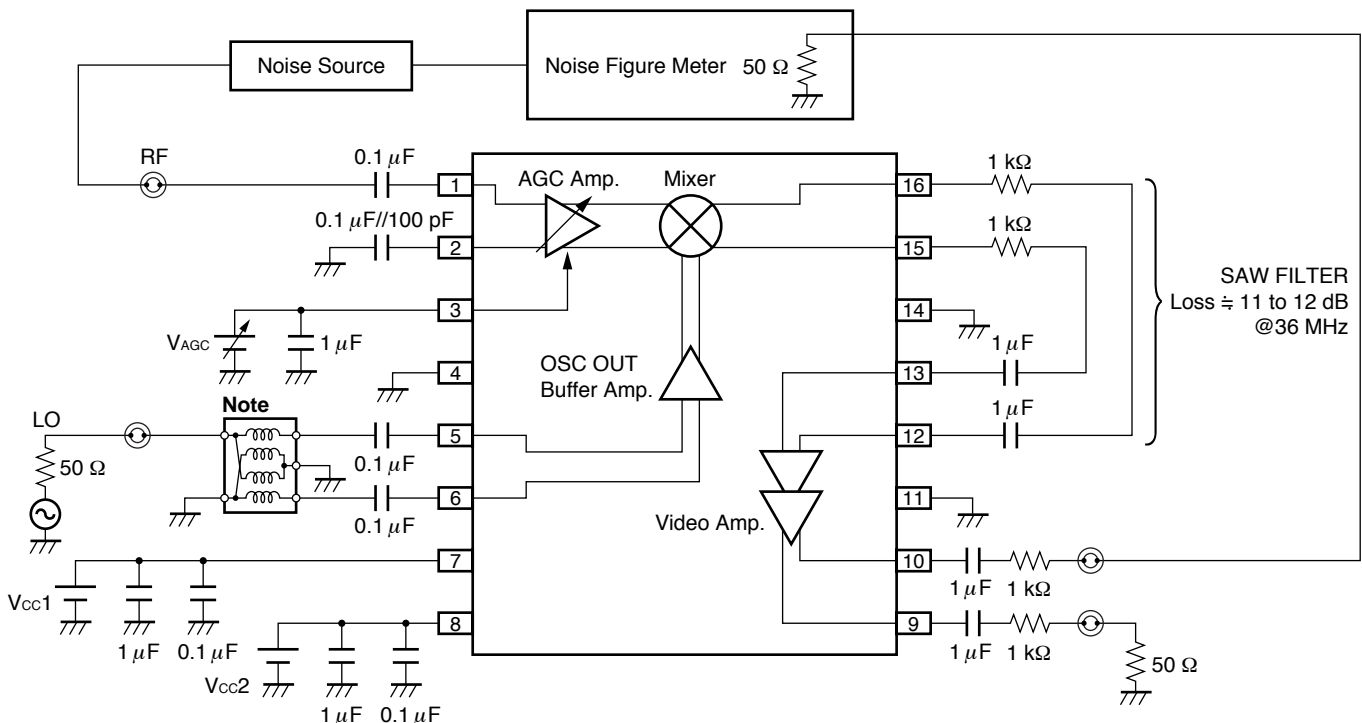

Note: Balun Transformer : TOKO 617DB-1010 B4F (Double balanced type)

PACKAGE DIMENSIONS (Units in mm)

PACKAGE OUTLINE S16

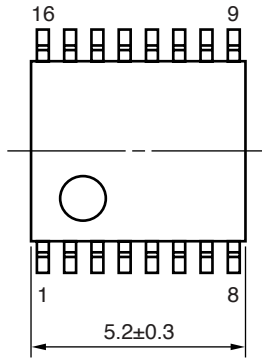

detail of lead end

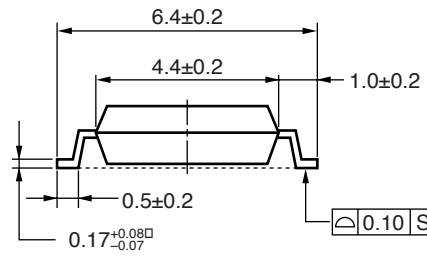
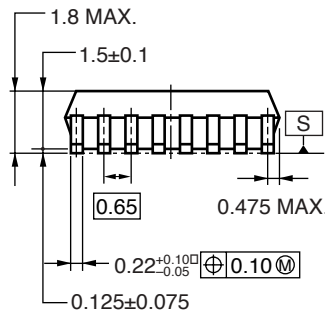
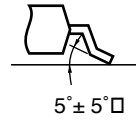

Note:

1. All dimensions are typical unless otherwise specified.

ORDERING INFORMATION

PART NUMBER	QUANTITY
UPC3220GR-E1	2.5 k/Reel

Notes:

Embossed tape, 12 mm wide. Pin 1 indicates pull-out direction of tape.

Life Support Applications

These NEC products are not intended for use in life support devices, appliances, or systems where the malfunction of these products can reasonably be expected to result in personal injury. The customers of CEL using or selling these products for use in such applications do so at their own risk and agree to fully indemnify CEL for all damages resulting from such improper use or sale.

CEL California Eastern Laboratories, Your source for NEC RF, Microwave, Optoelectronic, and Fiber Optic Semiconductor Devices.

4590 Patrick Henry Drive • Santa Clara, CA 95054-1817 • (408) 988-3500 • FAX (408) 988-0279 • www.cel.com

DATA SUBJECT TO CHANGE WITHOUT NOTICE

01/09/2003