

BIPOLAR ANALOG INTEGRATED CIRCUIT
μPC29S00 Series

LOW DROPOUT VOLTAGE REGULATOR WITH ON/OFF FUNCTION

The μPC29S00 series is a low dropout regulator which has 100 mA capable for the output current. This series features ON/OFF function to control output voltage.

The μPC29S00 series is suitable for NEC's single chip microcontroller which have on-chip flash memory. The μPC29S00 series is use of erasing and writing data on its flash memory.

FEATURES

- ON/OFF control function (Active high)
 - Output current excess of 100 mA
 - Surface mount device package
 - High accuracy output voltage : ±2% (7.8 V output)
 -2% to +1% (10 V output)
 - On-chip all kinds of protection circuit
- ★ : 4-pin plastic SIP (TO-126 Gullwing) (7.8 V output)
 8-pin plastic SOP (225mil) (7.8 V output, 10 V output)

ORDERING INFORMATION

Part Number	Package	Output Voltage
μPC29S78H	4-pin plastic SIP (TO-126)	7.8 V
μPC29S78TA	4-pin plastic SIP (TO-126 Gullwing)	7.8 V
★ μPC29S78GR	8-pin plastic SOP (225 mil)	7.8 V
μPC29S10GR	8-pin plastic SOP (225 mil)	10 V

PIN CONFIGURATIONS (Marking Side)

TO-126

- μPC29S78H

TO-126 Gullwing

- μPC29S78TA

8-pin plastic SOP (225mil)

- ★ • μPC29S78GR
- μPC29S10GR

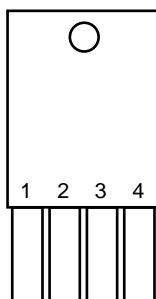

1: INPUT
 2: ON/OFF
 3: GND
 4: OUTPUT

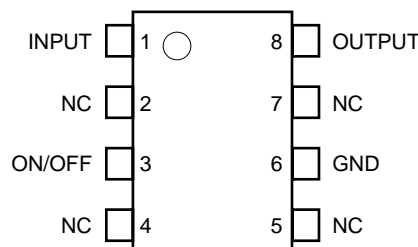

The information in this document is subject to change without notice. Before using this document, please confirm that this is the latest version.
 Not all devices/types available in every country. Please check with local NEC representative for availability and additional information.

BLOCK DIAGRAM

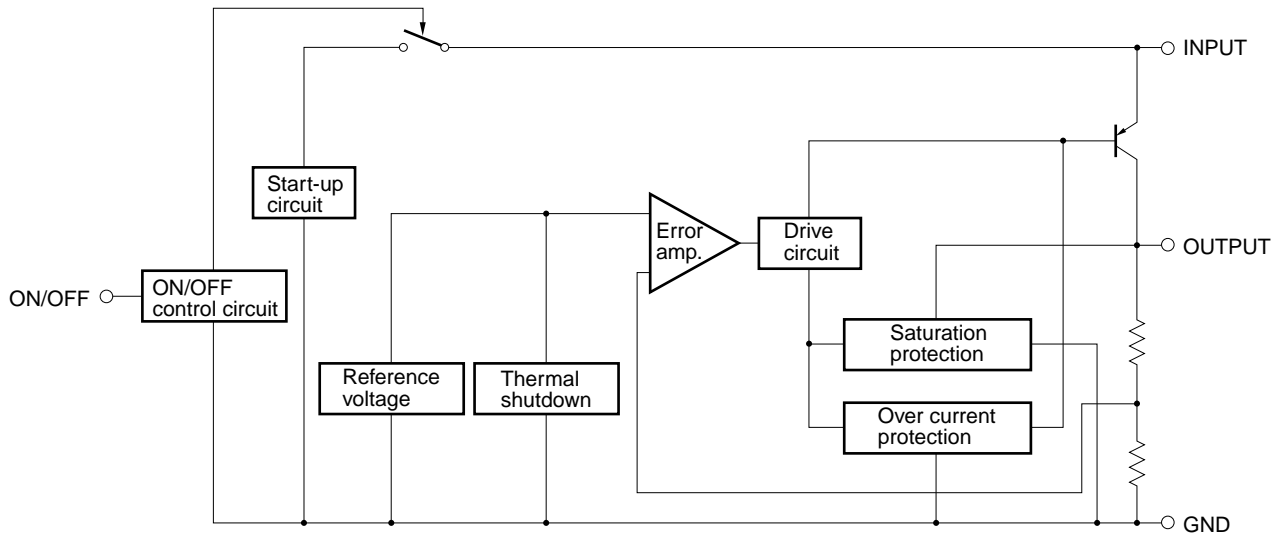

★ **ABSOLUTE MAXIMUM RATINGS** ($T_A = 25^\circ\text{C}$, unless otherwise specified.)

Parameter	Symbol	Rating		Unit
		μPC29S78H, 29S78TA	μPC29S78GR, 29S10GR	
Input Voltage	V_{IN}	20		V
Internal Power Dissipation	P_T ^{Note}	1.2	0.48	W
Operating Ambient Temperature	T_A	-30 to +85		°C
Operating Junction Temperature	T_J	-30 to +150		°C
Storage Temperature	T_{stg}	-55 to +150		°C
Thermal Resistance (Junction to Ambient)	$R_{th (J-A)}$	104	260	°C/W

Note $T_A \leq 25^\circ\text{C}$, Internally limited

When operating junction temperature rises up to 150°C, the internal circuit shutdown output voltage.

Caution Exposure to Absolute Maximum Ratings for extended periods may affect device reliability; exceeding the ratings could cause permanent damage. The parameters apply independently. The device should be operated within the limits specified under DC and AC Characteristics.

TYPICAL CONNECTION

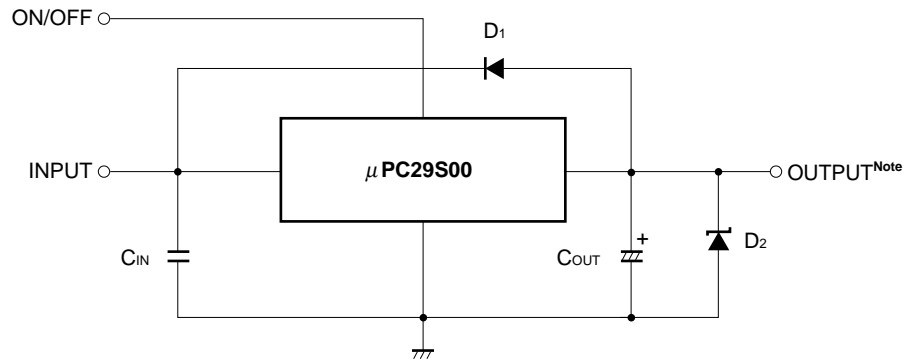

- C_{IN} : 0.1 to 0.47 μ F. Be sure to connect to prevent abnormal oscillation. For using capacitors, film capacitors whose voltage and temperature characteristics are excellent are recommended. Take care that some monolithic ceramic capacitor is inferior in the temperature and voltage characteristics. When using the monolithic ceramic capacitor, the C_{IN} needs to be held these capacities in voltage and temperature used.
- C_{OUT} : 10 μ F or higher. Be sure to connect to prevent oscillation and to improve the transient load stabilization.

Remark Connect the C_{IN} and C_{OUT} to IC pins as close as possible (2 cm or less).

- D_1 : Need for $V_o > V_{IN}$
- D_2 : Need a shottky barrier diode for $V_o < GND$.

Note When output is off ($V_{ON/OFF} = \text{low level}$), OUTPUT pin should not be supplied higher voltage than V_{IN} voltage from external.

★ **Caution** When using the μ PC29S78GR and μ PC29S10GR, design your circuit and mounting with consideration for heat radiation.

RECOMMENDED OPERATING CONDITIONS

Parameter	Symbol	Condition	MIN.	TYP.	MAX.	Unit
Input Voltage	V _{IN}	μPC29S78	8.8		18	V
		μPC29S10	11		18	V
Output Current	I _o		0		100	mA
Operating Ambient Temperature	T _A		-30		+85	°C
Operating Junction Temperature	T _J		-30		+125	°C

Caution If the Absolute Maximum Rating is not exceeded, there is no problem for using recommended operating range or more. Use and evaluate the μPC29S00 Series since the leeway is decreased with the Absolute Maximum Rating. Moreover, the recommended operating range is not prescribed to use when all parameters are maximum value.

ELECTRICAL CHARACTERISTICS

μPC29S78 (V_{IN} = 12 V, I_o = 50 mA, V_{ON/OFF} = 5 V, T_J = 25°C, unless otherwise specified.)

Parameter	Symbol	Conditions	MIN.	TYP.	MAX.	Unit
Output Voltage	V _o		7.64	7.8	7.96	V
		8.5 V ≤ V _{IN} ≤ 18 V, 0 mA ≤ I _o ≤ 50 mA, 0°C ≤ T _J ≤ +125°C	7.56		8.04	
		0 mA ≤ I _o ≤ 100 mA, 0°C ≤ T _J ≤ +125°C	7.56		8.04	
Line Regulation	REG _{IN}	8.8 V ≤ V _{IN} ≤ 18 V		22	75	mV
Load Regulation	REG _L	0 mA ≤ I _o ≤ 100 mA		21	75	mV
Quiescent Current	I _{BIAS}	I _o = 0 mA		3.0	5.0	mA
		I _o = 100 mA		11	25	
Start-up Quiescent Current	I _{BIAS(s)1}	V _{IN} = 7.3 V, I _o = 0 mA		10	20	mA
	I _{BIAS(s)2}	V _{IN} = 7.3 V, I _o = 100 mA			50	mA
Quiescent Current Change	ΔI _{BIAS}	8.8 V ≤ V _{IN} ≤ 18 V, 0°C ≤ T _J ≤ +125°C			10	mA
Output Noise Voltage	V _n	10 Hz ≤ f ≤ 100 kHz		160		μV _{r.m.s.}
Ripple Rejection	R·R	f = 120 Hz, 8.8 V ≤ V _{IN} ≤ 13.5 V	42	51		dB
Dropout Voltage	V _{DIF}	I _o = 100 mA, 0°C ≤ T _J ≤ +125°C			1.0	V
Peak Output Current	I _{o peak}	V _{IN} = 9.8 V	150	250	400	mA
Short Circuit Current	I _{o short}	V _{IN} = 18 V		250		mA
Temperature Coefficient of Output Voltage	ΔV _o /ΔT	I _o = 5 mA, 0°C ≤ T _J ≤ +125°C		-0.4		mV/°C
ON/OFF Voltage	V _{ON/OFF1}	V _{IN} = 12 V, I _o = 10 mA		1.8	2.0	V
	V _{ON/OFF2}	V _{IN} = 12 V, I _o = 0 mA	0.8	1.6		V
ON/OFF Current	I _{ON/OFF1}	V _{ON/OFF} = 2.7 V, I _o = 0 mA		250	450	μA
	I _{ON/OFF2}	V _{ON/OFF} = 5 V, I _o = 0 mA		450	800	μA
Standby Current	I _{BIAS OFF}	V _{ON/OFF} = 0 V, I _o = 0 mA			10	μA

μ PC29S10 ($V_{IN} = 12\text{ V}$, $I_o = 50\text{ mA}$, $V_{ON/OFF} = 5\text{ V}$, $T_J = 25^\circ\text{C}$, unless otherwise specified.)

Parameter	Symbol	Conditions	MIN.	TYP.	MAX.	Unit
Output Voltage	V_o		9.80	10.00	10.10	V
		$11\text{ V} \leq V_{IN} \leq 18\text{ V}$, $0\text{ mA} \leq I_o \leq 50\text{ mA}$, $0^\circ\text{C} \leq T_J \leq +125^\circ\text{C}$	9.70		10.20	
		$0\text{ mA} \leq I_o \leq 100\text{ mA}$, $0^\circ\text{C} \leq T_J \leq +125^\circ\text{C}$	9.70		10.20	
Line Regulation	REG_{IN}	$11\text{ V} \leq V_{IN} \leq 18\text{ V}$		27	100	mV
Load Regulation	REG_L	$0\text{ mA} \leq I_o \leq 100\text{ mA}$		18	100	mV
Quiescent Current	I_{BIAS}	$I_o = 0\text{ mA}$		3.3	5.0	mA
		$I_o = 100\text{ mA}$		12	25	
Start-up Quiescent Current	$I_{BIAS(s)1}$	$V_{IN} = 9.5\text{ V}$, $I_o = 0\text{ mA}$		10	20	mA
	$I_{BIAS(s)2}$	$V_{IN} = 9.5\text{ V}$, $I_o = 100\text{ mA}$			50	
Quiescent Current Change	ΔI_{BIAS}	$11\text{ V} \leq V_{IN} \leq 18\text{ V}$, $0^\circ\text{C} \leq T_J \leq +125^\circ\text{C}$		1.0	10	mA
Output Noise Voltage	V_n	$10\text{ Hz} \leq f \leq 100\text{ kHz}$		210		$\mu\text{V}_{r.m.s.}$
Ripple Rejection	R·R	$f = 120\text{ Hz}$, $11\text{ V} \leq V_{IN} \leq 13.5\text{ V}$	40	48		dB
Dropout Voltage	V_{DIF}	$I_o = 100\text{ mA}$, $0^\circ\text{C} \leq T_J \leq +125^\circ\text{C}$		0.4	1.0	V
Peak Output Current	$I_{O\text{ peak}}$	$V_{IN} = 12\text{ V}$	150	250	400	mA
Short Circuit Current	$I_{O\text{ short}}$	$V_{IN} = 18\text{ V}$		180		mA
Temperature Coefficient of Output Voltage	$\Delta V_o/\Delta T$	$I_o = 5\text{ mA}$, $0^\circ\text{C} \leq T_J \leq +125^\circ\text{C}$		-0.5		$\text{mV}/^\circ\text{C}$
ON/OFF Voltage	$V_{ON/OFF1}$	$V_{IN} = 12\text{ V}$, $I_o = 10\text{ mA}$		1.8	2.0	V
	$V_{ON/OFF2}$	$V_{IN} = 12\text{ V}$, $I_o = 0\text{ mA}$	0.8	1.6		
ON/OFF Current	$I_{ON/OFF1}$	$V_{ON/OFF} = 2.7\text{ V}$, $I_o = 0\text{ mA}$		250	450	μA
	$I_{ON/OFF2}$	$V_{ON/OFF} = 5\text{ V}$, $I_o = 0\text{ mA}$		450	800	
Standby Current	$I_{BIAS\text{ OFF}}$	$V_{ON/OFF} = 0\text{ V}$, $I_o = 0\text{ mA}$			10	μA

TYPICAL CHARACTERISTICS (REFERENCE VALUES)

★ P_T vs T_A

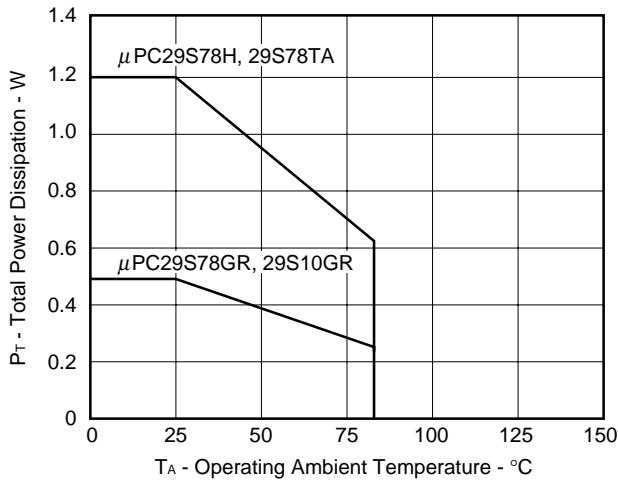

V_O vs V_{IN}

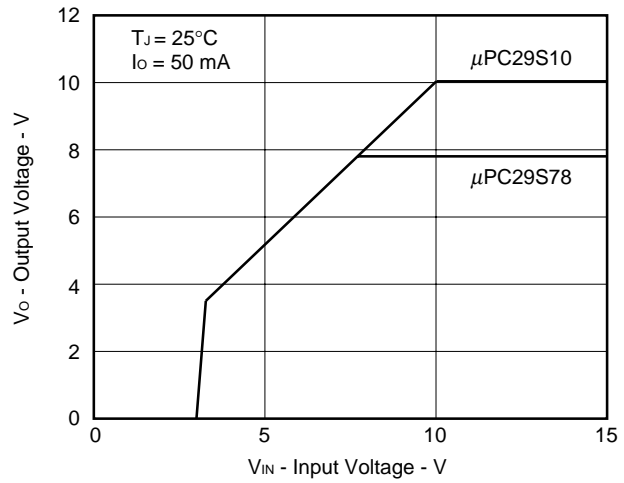

I_{BIAS} ($I_{BIAS(s)}$) vs V_{IN} (μ PC29S78)

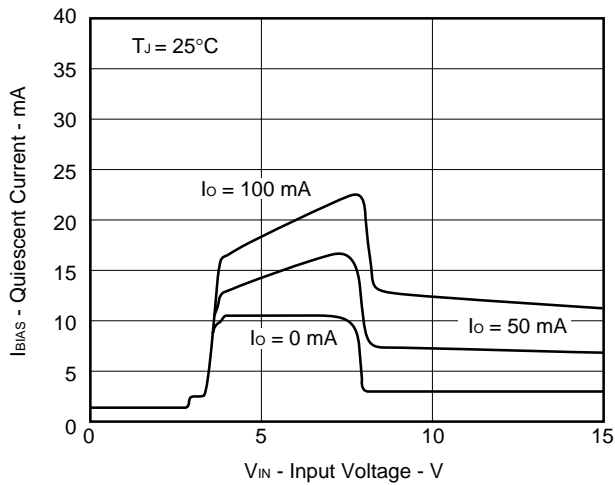

I_{BIAS} ($I_{BIAS(s)}$) vs V_{IN} (μ PC29S10)

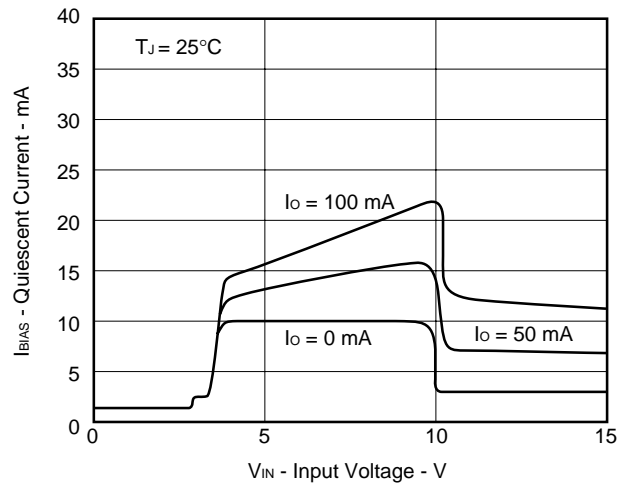

V_O vs $V_{ON/OFF}$

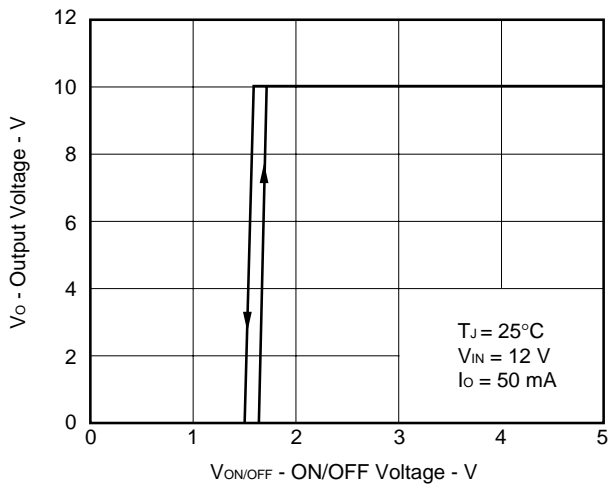

ΔV_O vs T_J

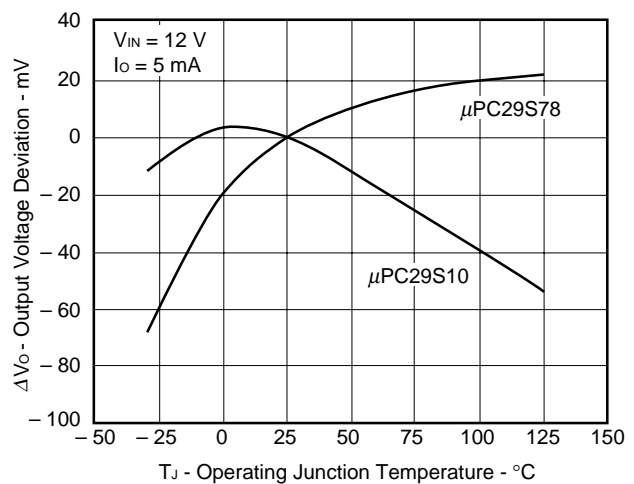

$I_{O\ peak}$ VS ($V_{IN} - V_O$)

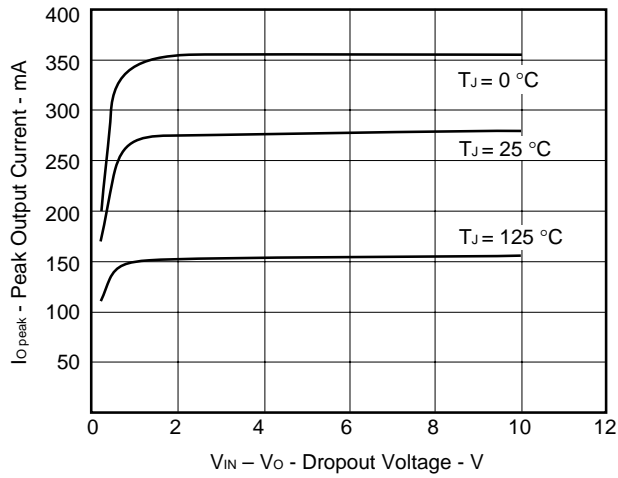

R•R vs f

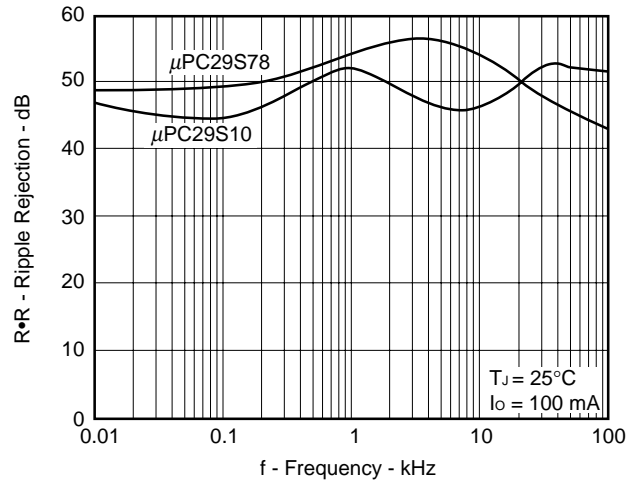

V_{DIF} VS I_O

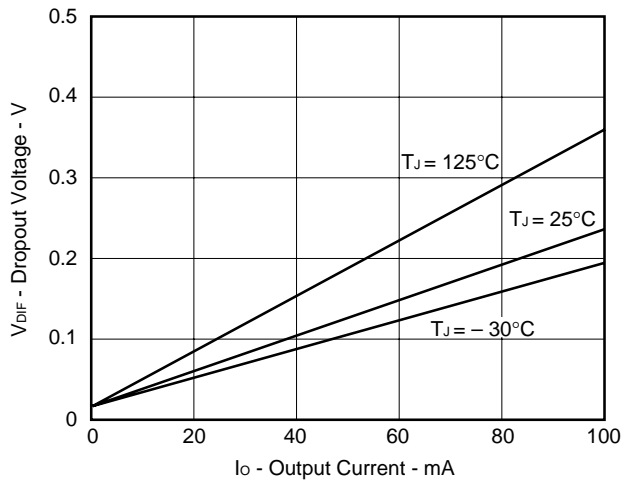

V_{DIF} VS T_J

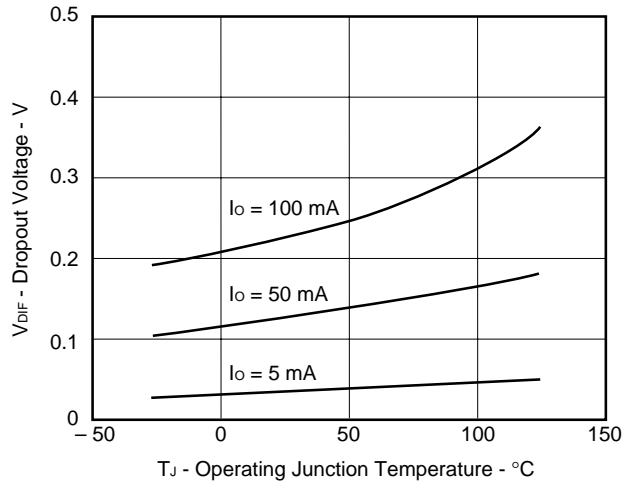

PACKAGE DRAWINGS

4 PIN PLASTIC SIP (TO-126)

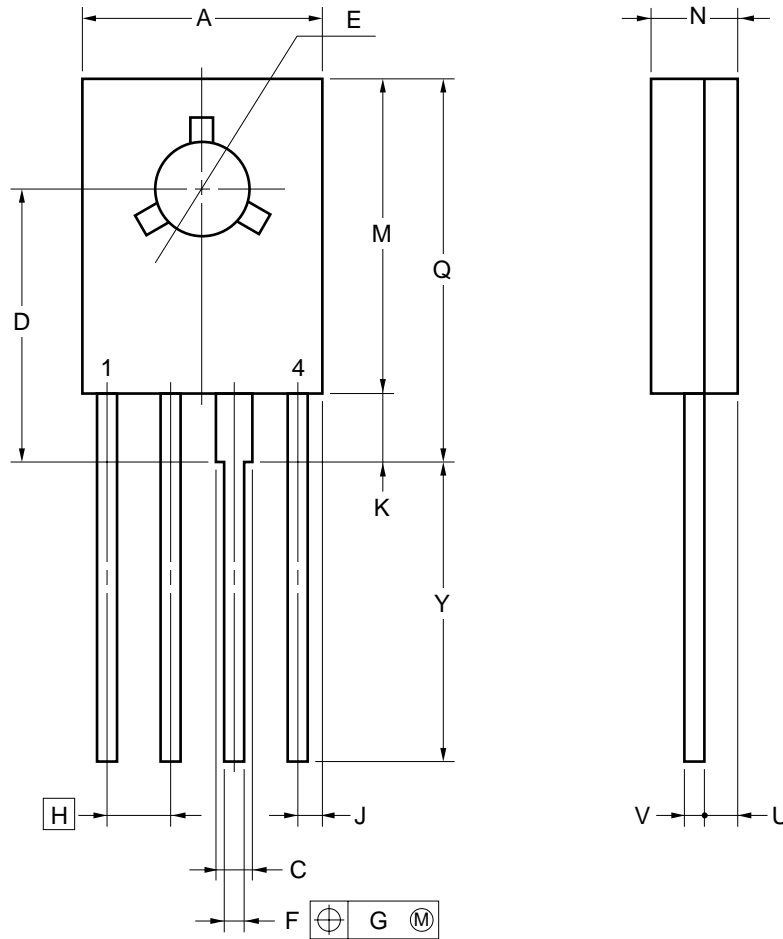

NOTE
 Each lead centerline is located within 0.2 mm (0.008 inch) of its true position (T.P.) at maximum material condition.

ITEM	MILLIMETERS	INCHES
A	8.5 MAX.	0.335 MAX.
C	1.1 MIN.	0.043 MIN.
D	9.7±0.3	0.382±0.012
E	φ3.2±0.1	φ0.126±0.004
F	0.65±0.1	0.026 ^{+0.004} _{-0.005}
G	0.2	0.008
H	2.0	0.079
J	1.25 MAX.	0.05 MAX.
K	2.3 MIN.	0.09 MIN.
M	11.5 MAX.	0.453 MAX.
N	2.7±0.2	0.106 ^{+0.009} _{-0.008}
Q	14.5 MAX.	0.571 MAX.
U	1.7 MAX.	0.067 MAX.
V	0.55±0.1	0.022 ^{+0.004} _{-0.005}
Y	13.5±0.7	0.531 ^{+0.029} _{-0.028}

P4HP-200B-1

4 PIN PLASTIC SIP (TO-126 GULLWING)

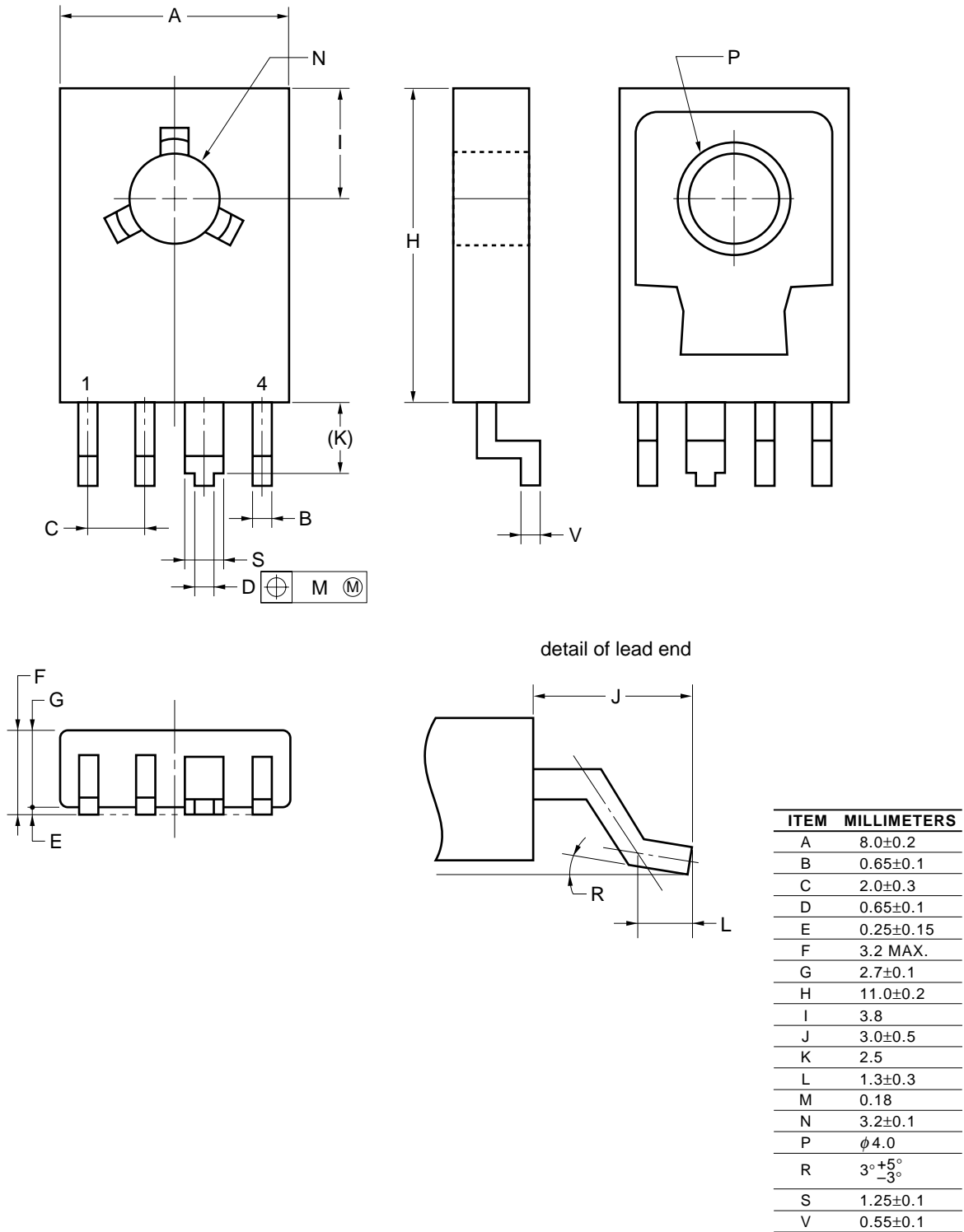

8 PIN PLASTIC SOP (225 mil)

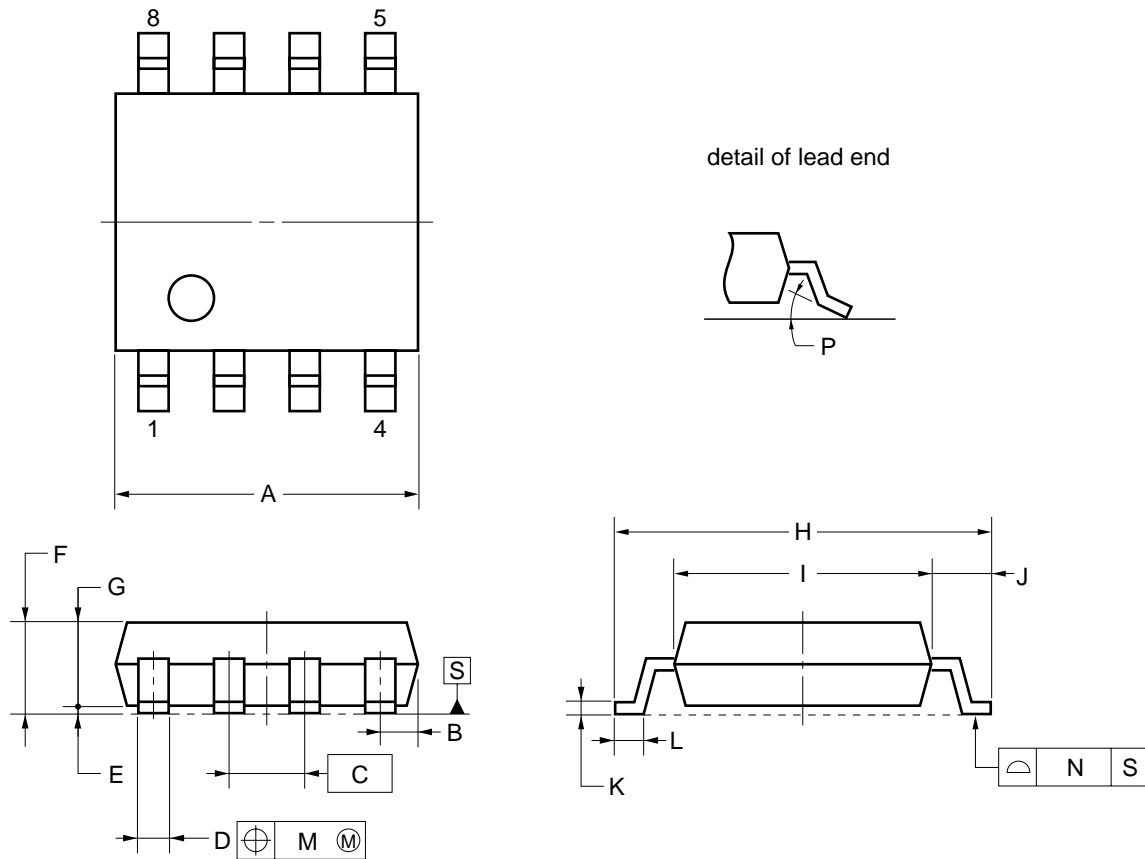

NOTE
 Each lead centerline is located within 0.12 mm of its true position (T.P.) at maximum material condition.

ITEM	MILLIMETERS
A	5.2 ^{+0.17} _{-0.20}
B	0.78 MAX.
C	1.27 (T.P.)
D	0.42 ^{+0.08} _{-0.07}
E	0.1±0.1
F	1.59±0.21
G	1.49
H	6.5±0.3
I	4.4±0.15
J	1.1±0.2
K	0.17 ^{+0.08} _{-0.07}
L	0.6±0.2
M	0.12
N	0.10
P	3° ^{+7°} _{-3°}

S8GM-50-225B-5

RECOMMENDED SOLDERING CONDITIONS

When soldering these products, it is highly recommended to observe the conditions as shown below. If other soldering processes are used, or if the soldering is performed under different conditions, please make sure to consult with our sales offices.

For more details, refer to our document “SEMICONDUCTOR DEVICE MOUNTING TECHNOLOGY MANUAL” (C10535E).

Surface mount devices

μPC29S78TA: 4-pin plastic SIP (TO-126 Gullwing)

Process	Conditions	Symbol
Infrared ray reflow	Peak temperature: 235°C or below (Package surface temperature), Reflow time: 30 seconds or less (at 210°C or higher), Maximum number of reflow processes: 2 times.	IR35-00-2
VPS	Peak temperature: 215°C or below (Package surface temperature), Reflow time: 40 seconds or less (at 200°C or higher), Maximum number of reflow processes: 2 times.	VP15-00-2
Wave soldering	Solder temperature: 260°C or below, Flow time: 10 seconds or less, Maximum number of flow processes: 1 time, Pre-heating temperature: 120°C or below (Package surface temperature).	WS60-00-1
Partial heating method	Pin temperature: 300°C or below, Heat time: 3 seconds or less (Per each side of the device).	—

Caution Apply only one kind of soldering condition to a device, except for “partial heating method”, or the device will be damaged by heat stress.

★

μPC29S78GR, 29S10GR: 8-pin plastic SOP (225 mil)

Process	Conditions	Symbol
Infrared ray reflow	Peak temperature: 235°C or below (Package surface temperature), Reflow time: 30 seconds or less (at 210°C or higher), Maximum number of reflow processes: 3 times.	IR35-00-3
VPS	Peak temperature: 215°C or below (Package surface temperature), Reflow time: 40 seconds or less (at 200°C or higher), Maximum number of reflow processes: 3 times.	VP15-00-3
Wave soldering	Solder temperature: 260°C or below, Flow time: 10 seconds or less, Maximum number of flow processes: 1 time, Pre-heating temperature: 120°C or below (Package surface temperature).	WS60-00-1
Partial heating method	Pin temperature: 300°C or below, Heat time: 3 seconds or less (Per each side of the device).	—

Caution Apply only one kind of soldering condition to a device, except for “partial heating method”, or the device will be damaged by heat stress.

Through-hole device

μPC29S78H: 4-pin plastic SIP (TO-126)

Process	Conditions
Wave soldering (only to leads)	Solder temperature: 260°C or below, Flow time: 10 seconds or less.
Partial heating method	Pin temperature: 300°C or below, Heat time: 3 seconds or less (per each lead).

Caution For through-hole device, the wave soldering process must be applied only to leads, and make sure that the package body does not get jet soldered.

CAUTION ON USE

When using the μPC29S00 series at the input voltage which is lower than in the recommended operating condition, the big quiescent current flows through device because the transistor of the output paragraph is saturated (Refer to I_{BIAS} (I_{BIAS (s)}) vs V_{IN} curves in **TYPICAL CHARACTERISTICS**). The μPC29S00 series has saturation protection circuits, but they sometimes need about 50 mA current. Therefore the power supply on the input needs the enough current capacity to pass this quiescent current when the device start-up.

REFERENCE DOCUMENTS

QUALITY GRADES ON NEC SEMICONDUCTOR DEVICES	C11531E
SEMICONDUCTOR DEVICE MOUNTING TECHNOLOGY MANUAL	C10535E
SEMICONDUCTORS SELECTION GUIDE	X10679E

[MEMO]

[MEMO]

[MEMO]

[MEMO]

- **The information in this document is subject to change without notice. Before using this document, please confirm that this is the latest version.**
 - No part of this document may be copied or reproduced in any form or by any means without the prior written consent of NEC Corporation. NEC Corporation assumes no responsibility for any errors which may appear in this document.
 - NEC Corporation does not assume any liability for infringement of patents, copyrights or other intellectual property rights of third parties by or arising from use of a device described herein or any other liability arising from use of such device. No license, either express, implied or otherwise, is granted under any patents, copyrights or other intellectual property rights of NEC Corporation or others.
 - Descriptions of circuits, software, and other related information in this document are provided for illustrative purposes in semiconductor product operation and application examples. The incorporation of these circuits, software, and information in the design of the customer's equipment shall be done under the full responsibility of the customer. NEC Corporation assumes no responsibility for any losses incurred by the customer or third parties arising from the use of these circuits, software, and information.
 - While NEC Corporation has been making continuous effort to enhance the reliability of its semiconductor devices, the possibility of defects cannot be eliminated entirely. To minimize risks of damage or injury to persons or property arising from a defect in an NEC semiconductor device, customers must incorporate sufficient safety measures in its design, such as redundancy, fire-containment, and anti-failure features.
 - NEC devices are classified into the following three quality grades:
"Standard", "Special", and "Specific". The Specific quality grade applies only to devices developed based on a customer designated "quality assurance program" for a specific application. The recommended applications of a device depend on its quality grade, as indicated below. Customers must check the quality grade of each device before using it in a particular application.
 - Standard: Computers, office equipment, communications equipment, test and measurement equipment, audio and visual equipment, home electronic appliances, machine tools, personal electronic equipment and industrial robots
 - Special: Transportation equipment (automobiles, trains, ships, etc.), traffic control systems, anti-disaster systems, anti-crime systems, safety equipment and medical equipment (not specifically designed for life support)
 - Specific: Aircraft, aerospace equipment, submersible repeaters, nuclear reactor control systems, life support systems or medical equipment for life support, etc.
- The quality grade of NEC devices is "Standard" unless otherwise specified in NEC's Data Sheets or Data Books. If customers intend to use NEC devices for applications other than those specified for Standard quality grade, they should contact an NEC sales representative in advance.