

# 8-Bit Scannable Register

The MC10E/100E241 is an 8-bit shiftable register. Unlike a standard universal shift register such as the E141, the E241 features internal data feedback organized so that the SHIFT control overrides the HOLD/LOAD control. This enables the normal operations of HOLD and LOAD to be toggled with a single control line without the need for external gating. It also enables switching to scan mode with the single SHIFT control line.

The eight inputs D<sub>0</sub> – D<sub>7</sub> accept parallel input data, while S-IN accepts serial input data when in shift mode. Data is accepted a set-up time before the positive-going edge of CLK; shifting is also accomplished on the positive clock edge. A HIGH on the Master Reset pin (MR) asynchronously resets all the registers to zero.

- SHIFT overrides HOLD/LOAD Control
- 1000ps Max. CLK to Q
- Asynchronous Master Reset
- Pin-Compatible with E141
- Extended 100E V<sub>EE</sub> Range of – 4.2V to – 5.46V
- 75kΩ Input Pulldown Resistors

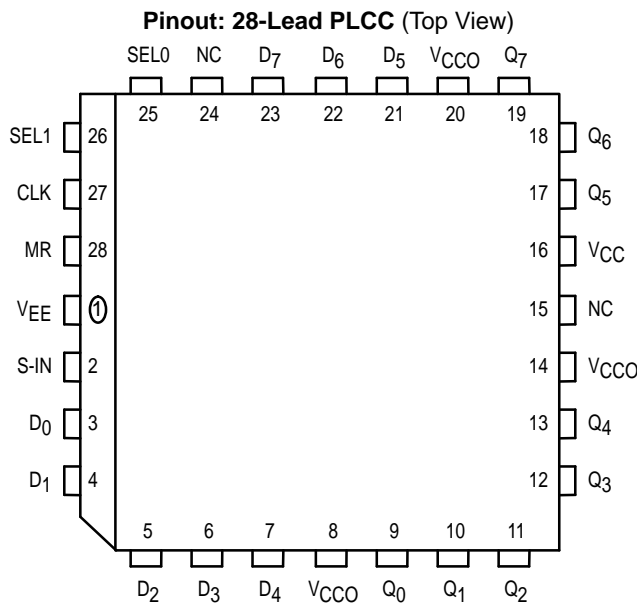

\* All V<sub>CC</sub> and V<sub>CCO</sub> pins are tied together on the die.

**PIN NAMES**

Pin	Function
D <sub>0</sub> – D <sub>7</sub>	Parallel Date Inputs
S-IN	Serial Data Inputs
SEL0	SHIFT Control
SEL1	HOLD/LOAD Control
CLK	Clock
MR	Master Reset
Q <sub>0</sub> – Q <sub>7</sub>	Data Outputs

**MC10E241**  
**MC100E241**

**8-BIT SCANNABLE REGISTER**



**LOGIC DIAGRAM**

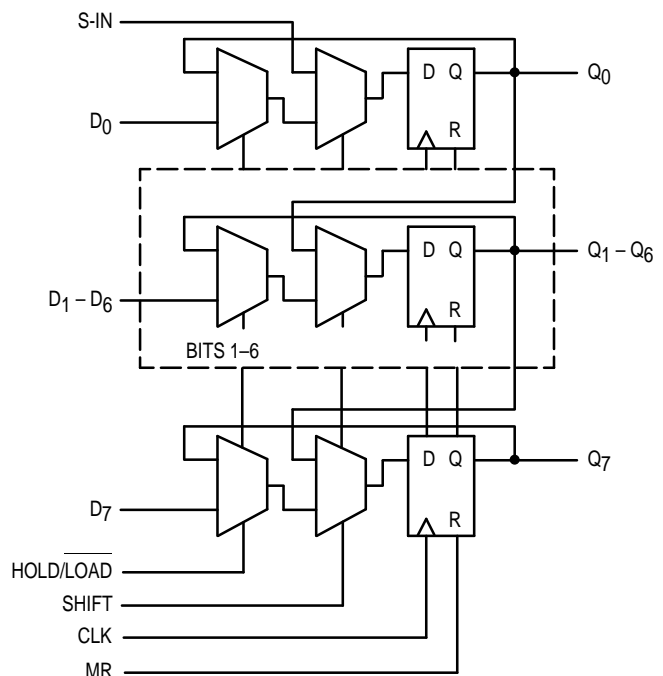

# MC10E241 MC100E241

## DC CHARACTERISTICS (V<sub>EE</sub> = V<sub>EE(min)</sub> to V<sub>EE(max)</sub>; V<sub>CC</sub> = V<sub>CCO</sub> = GND)

Symbol	Characteristic	0°C			25°C			85°C			Unit	Condition
		min	typ	max	min	typ	max	min	typ	max		
I <sub>IH</sub>	Input HIGH Current			150			150			150	μA	
I <sub>EE</sub>	Power Supply Current										MA	
	10E		125	150		125	150		125	150		
	100E		125	150		125	150		144	173		

## AC CHARACTERISTICS (V<sub>EE</sub> = V<sub>EE(min)</sub> to V<sub>EE(max)</sub>; V<sub>CC</sub> = V<sub>CCO</sub> = GND)

Symbol	Characteristic	0°C			25°C			85°C			Unit	Condition
		min	typ	max	min	typ	max	min	typ	max		
f <sub>SHIFT</sub>	Max. Shift Frequency	700	900		700	900		700	900		MHz	
t <sub>PLH</sub> t <sub>PHL</sub>	Propagation Delay to Output Clk MR	625 600	750 725	975 975	625 600	750 725	975 975	625 600	750 725	975 975	ps	
t <sub>s</sub>	Setup Time D SEL0 (SHIFT) SEL1 (HOLD/LOAD) S-IN	175 350 400 125	25 200 250 -100		175 350 400 125	25 200 250 -100		175 350 400 125	25 200 250 -100		ps	
t <sub>h</sub>	Hold Time D SEL0 (SHIFT) SEL1 (HOLD/LOAD) S-IN	200 100 50 300	-25 -200 -250 100		200 100 50 300	-25 -200 -250 100		200 100 50 300	-25 -200 -250 100		ps	
t <sub>RR</sub>	Reset Recovery Time	900	600		900	600		900	600		ps	
t <sub>PW</sub>	Minimum Pulse Width Clk, MR	400			400			400			ps	
t <sub>SKEW</sub>	Within-Device Skew		60			60			60		ps	1
t <sub>r</sub> t <sub>f</sub>	Rise/Fall Times 20 - 80%	300	525	800	300	525	800	300	525	800	ps	

1. Within-device skew is defined as identical transitions on similar paths through a device.

## FUNCTION TABLE

MR	SEL0	SEL1	Function
1	X	X	Outputs LOW
0	1	X	Shift Data
0	0	1	Hold Data
0	0	0	Load Data

OUTLINE DIMENSIONS

FN SUFFIX  
 PLASTIC PLCC PACKAGE  
 CASE 776-02  
 ISSUE D



NOTES:

- DATUMS -L-, -M-, AND -N- DETERMINED WHERE TOP OF LEAD SHOULDER EXITS PLASTIC BODY AT MOLD PARTING LINE.
- DIM G1, TRUE POSITION TO BE MEASURED AT DATUM -T-, SEATING PLANE.
- DIM R AND U DO NOT INCLUDE MOLD FLASH. ALLOWABLE MOLD FLASH IS 0.010 (0.250) PER SIDE.
- DIMENSIONING AND TOLERANCING PER ANSI Y14.5M, 1982.
- CONTROLLING DIMENSION: INCH.
- THE PACKAGE TOP MAY BE SMALLER THAN THE PACKAGE BOTTOM BY UP TO 0.012 (0.300). DIMENSIONS R AND U ARE DETERMINED AT THE OUTERMOST EXTREMES OF THE PLASTIC BODY EXCLUSIVE OF MOLD FLASH, TIE BAR BURRS, GATE BURRS AND INTERLEAD FLASH, BUT INCLUDING ANY MISMATCH BETWEEN THE TOP AND BOTTOM OF THE PLASTIC BODY.
- DIMENSION H DOES NOT INCLUDE DAMBAR PROTRUSION OR INTRUSION. THE DAMBAR PROTRUSION(S) SHALL NOT CAUSE THE H DIMENSION TO BE GREATER THAN 0.037 (0.940). THE DAMBAR INTRUSION(S) SHALL NOT CAUSE THE H DIMENSION TO BE SMALLER THAN 0.025 (0.635).

DIM	INCHES		MILLIMETERS	
	MIN	MAX	MIN	MAX
A	0.485	0.495	12.32	12.57
B	0.485	0.495	12.32	12.57
C	0.165	0.180	4.20	4.57
E	0.090	0.110	2.29	2.79
F	0.013	0.019	0.33	0.48
G	0.050 BSC		1.27 BSC	
H	0.026	0.032	0.66	0.81
J	0.020	—	0.51	—
K	0.025	—	0.64	—
R	0.450	0.456	11.43	11.58
U	0.450	0.456	11.43	11.58
V	0.042	0.048	1.07	1.21
W	0.042	0.048	1.07	1.21
X	0.042	0.056	1.07	1.42
Y	—	0.020	—	0.50
Z	2°		10°	
G1	0.410	0.430	10.42	10.92
K1	0.040	—	1.02	—

Motorola reserves the right to make changes without further notice to any products herein. Motorola makes no warranty, representation or guarantee regarding the suitability of its products for any particular purpose, nor does Motorola assume any liability arising out of the application or use of any product or circuit, and specifically disclaims any and all liability, including without limitation consequential or incidental damages. "Typical" parameters which may be provided in Motorola data sheets and/or specifications can and do vary in different applications and actual performance may vary over time. All operating parameters, including "Typicals" must be validated for each customer application by customer's technical experts. Motorola does not convey any license under its patent rights nor the rights of others. Motorola products are not designed, intended, or authorized for use as components in systems intended for surgical implant into the body, or other applications intended to support or sustain life, or for any other application in which the failure of the Motorola product could create a situation where personal injury or death may occur. Should Buyer purchase or use Motorola products for any such unintended or unauthorized application, Buyer shall indemnify and hold Motorola and its officers, employees, subsidiaries, affiliates, and distributors harmless against all claims, costs, damages, and expenses, and reasonable attorney fees arising out of, directly or indirectly, any claim of personal injury or death associated with such unintended or unauthorized use, even if such claim alleges that Motorola was negligent regarding the design or manufacture of the part. Motorola and  are registered trademarks of Motorola, Inc. Motorola, Inc. is an Equal Opportunity/Affirmative Action Employer.

**How to reach us:**

**USA/EUROPE/Locations Not Listed:** Motorola Literature Distribution;  
P.O. Box 20912; Phoenix, Arizona 85036. 1-800-441-2447 or 602-303-5454

**MFAX:** RMFAX0@email.sps.mot.com – TOUCHTONE 602-244-6609  
**INTERNET:** <http://Design-NET.com>

**JAPAN:** Nippon Motorola Ltd.; Tatsumi-SPD-JLDC, 6F Seibu-Butsuryu-Center,  
3-14-2 Tatsumi Koto-Ku, Tokyo 135, Japan. 03-81-3521-8315

**ASIA/PACIFIC:** Motorola Semiconductors H.K. Ltd.; 8B Tai Ping Industrial Park,  
51 Ting Kok Road, Tai Po, N.T., Hong Kong. 852-26629298

