

MF1082V-2

FOR PCS MOBILE TELEPHONE, Tx

MF1082V-2

DESCRIPTION

This SAW filter for the transmitting RF circuit of PCS mobile communication equipment operating at 1850 MHz ~ 1910 MHz.

FEATURES

1. SMD package insures small size, lightweight.
2. Adjustment free.
3. Low insertion loss and high stop band attenuation.
4. Wide and sharp passband characteristics.
5. High stability and reliability.
6. Designed for reflow solderings.

APPLICATION

- Mobile cellular telephone
- Portable digital cellular telephone
- Wireless equipment

MAXIMUM RATINGS

Rating	Value	Unit
Input Power	20	mW
Operating Temperature Range	-20 to 75	°C
Storage Temperature Range	-30 to 85	°C

ELECTRICAL PERFORMANCE

Parameter	MF1082V-2			Units
	Min	Typ	Max	
PASSBAND FREQUENCY	1850 – 1910			MHz
PASSBAND CHARACTERISTICS	Insertion Loss	3.9	5.0	dB
	Ripple	2.0	3.0	dB
	VSWR	2.1	3.0	
STOPBAND ATTENUATION	0 – 1500 MHz	22	27	dB
	1500 – 1800 MHz	32	36	dB
	1930 – 1990 MHz	7	17	dB
	1990 – 2350 MHz	34	38	dB
	2350 – 3000 MHz	28	34	dB

PACKAGE OUTLINE DIMENSIONS

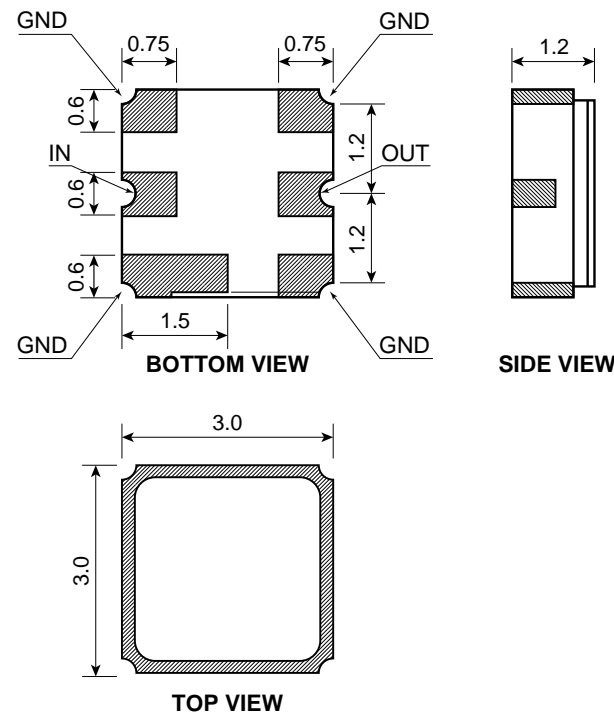

DIMENSIONS ARE IN MILLIMETERS
±0.2 UNLESS OTHERWISE SPECIFIED

MF1082V-2 TYPICAL CHARACTERISTICS

