

M54671SP

2-PHASE STEPPER MOTOR DRIVER

DESCRIPTION

The M54671SP is a semiconductor IC to drive a bipolar stepper motor directly by controlling the coil current with the constant current method.

FEATURES

- Wide output current control range (20 – 1200mA)
- Bipolar and constant current
- Built in a thermal shutdown circuit

APPLICATION

Office automation equipment such as printer, FDD, HDD, and FAX

FUNCTION

The M54671SP can drive a stepper motor by the 2-phase bipolar method and also control the coil current. Furthermore, it controls the direction of the coil current with Ph input pins (pins 16 and 17) and the coil current value with VR pins (pins 3 and 30).

Because two control circuits are built in this IC, a stepping motor can be driven with a single IC by the 2-phase bipolar method.

PIN CONFIGURATION (TOP VIEW)

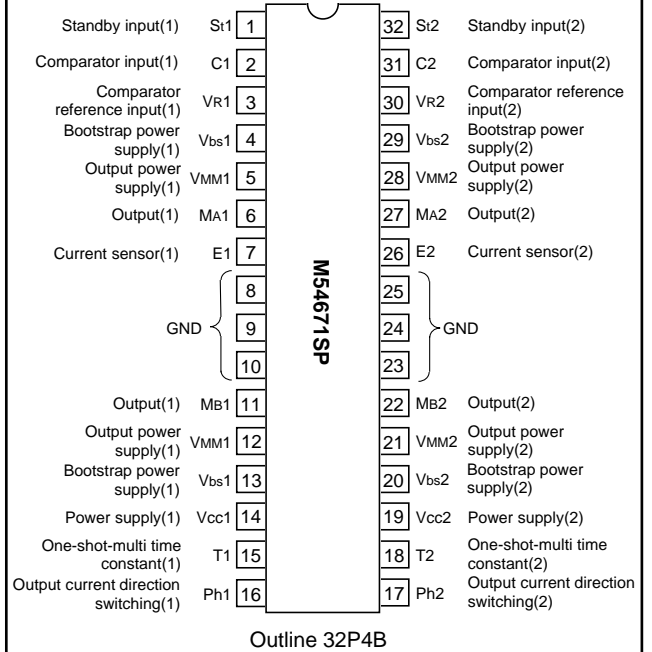

BLOCK DIAGRAM

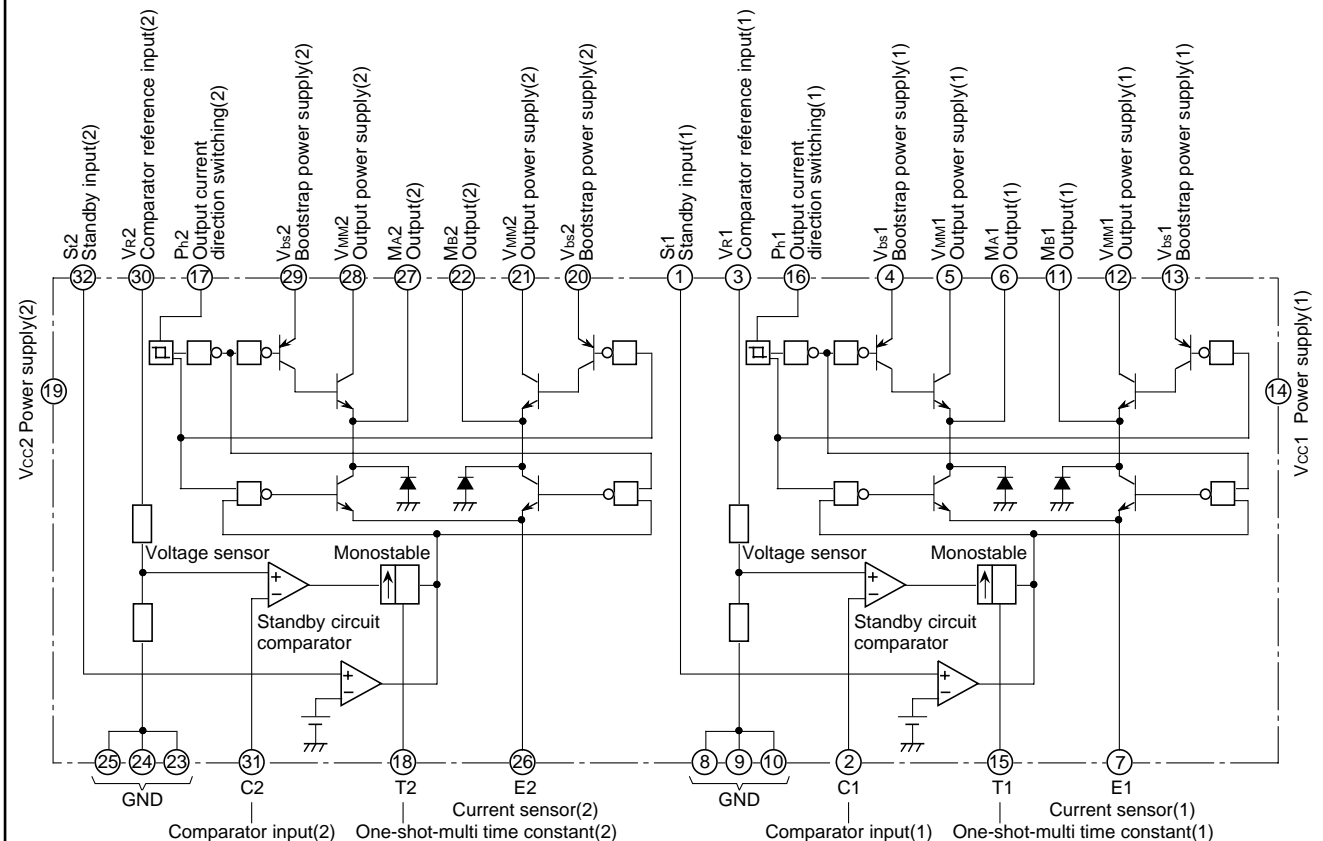

ABSOLUTE MAXIMUM RATINGS (Ta=25°C, unless otherwise noted)

Symbol	Parameter	Conditions	Ratings	Unit
V _{CC}	Supply voltage		-0.3 – 7	V
V _{MM}	Output supply voltage		-0.3 – 24	V
V _{bs}	Bootstrap supply voltage		-0.3 – 27	V
V _L	Logic input voltage		-0.3 – 6	V
V _C	Analog input voltage		-0.3 – V _{CC}	V
V _R	Comparative input voltage		-0.3 – 15	V
I _L	Logic input current		-10	mA
I _C	Analog input current		-10	mA
I _{MM}	Output supply current		±1500	mA
P _d	Allowable loss		1.70	W
T _{opr}	Operating temperature		-20 – 75	°C
T _{stg}	Storage temperature		-55 – 125	°C

RECOMMENDED OPERATING CONDITIONS (Ta=25°C, unless otherwise noted)

Symbol	Parameter	Limits			Unit
		Min.	Typ.	Max.	
V _{CC}	Supply voltage	4.5	5	5.5	V
V _{MM}	Output supply voltage	10	12	20	V
V _{bs}	Bootstrap supply voltage	V _{bs} ≥ V _{MM} +1V		24	V
I _o	Output current	20	800	1200	mA
t _{PLH}	Logic input rise time			2	μs
t _{PHL}	Logic input fall time			2	μs
T _{ON}	Thermal shutdown		160		°C

ELECTRICAL CHARACTERISTICS (Ta=25°C, unless otherwise noted)

Symbol	Parameter	Test conditions	Limits			Unit
			Min.	Typ.	Max.	
V _{IH}	Logic input voltage	V _{CC} =5V	2.0		V _{CC}	V
V _{IL}			0		0.8	V
V _{CH}	Comparator threshold	V _R =5V	420	450	480	mV
I _{CO}	Comparator input current		-20		20	μA
I _{OFF}	Output cutoff current				100	μA
V _{sat}	Saturation voltage	Voltage at sensing resistor is not included. V _{bs} =12.7V, V _{MM} =12V, I _o =800mA		1.0	1.5	V
t _{OFF}	Cutoff time	V _{MM} =12V, t _{ON} ≥ 5μs	5	10	15	μs
t _d	Turn-off delay	dV _K /dt ≥ 50mV/μs		1.6	2.0	μs
I _{CC}	Supply current	V _{CC} =5V, 1phase			25	mA
I _{IH}	Logic input current	"H"			100	μA
I _{IL}		"L"	V _I =2.4V			
			-0.4			mA

M54671SP

2-PHASE STEPPER MOTOR DRIVER

SWITCHING CHARACTERISTICS

Switching waveforms

VMA-VMB or VMB-VMA

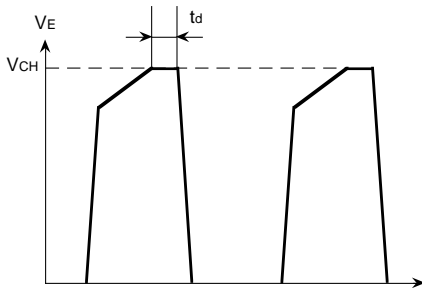
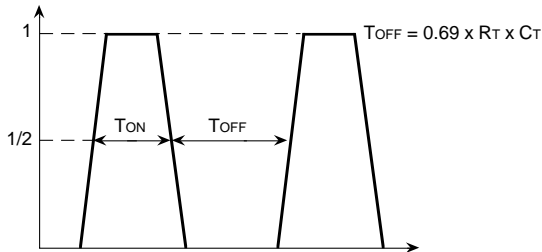

TIMING CHART

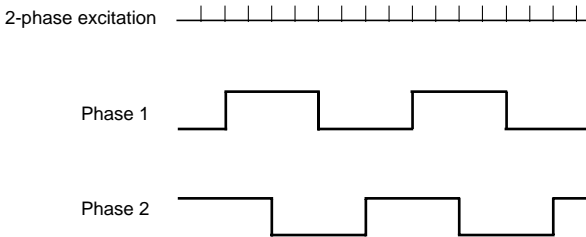

APPLICATION DESCRIPTION

(1) PHASE INPUT

Phase input decides the output mode.

PHASE	MA	MB
H	H	L
L	L	H

(2) VR (Comparative voltage)

The current level can be continuously changed by changing the voltage at VR continuously.

(3) Current sensor

When the voltage fall at the current sensing resistor and the selected current level become of the same level, the comparator triggers monostable. Then the output stage is cut off for a certain time (TOFF). During this cutoff time, the current decreases slightly and falls short of the comparative level.

After the cutoff time (TOFF), the output stage is in ON state again. This operation is repeated.

(4) Single pulse generator

At the comparator output rise edge, the monostable is triggered. The pulse width of the monostable at the external timing CT and RT is as follows.

$$T_{OFF} = 0.69 \times C_T \times R_T$$

Retrigger during TOFF is neglected.

(5) Analog control

The output current level can be continuously changed by changing the voltage at VR or the feedback voltage to the comparator.

TYPICAL CHARACTERISTICS

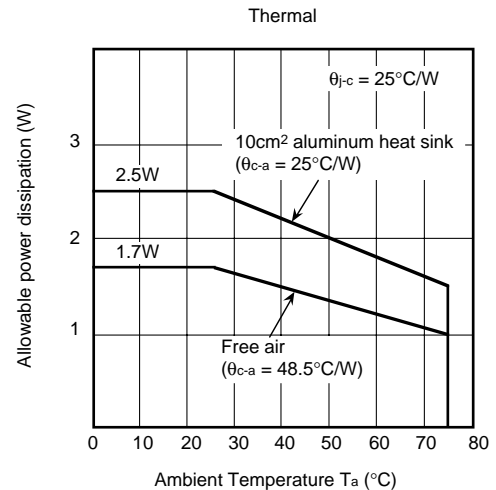

M54671SP

2-PHASE STEPPER MOTOR DRIVER

APPLICATION EXAMPLE (Stepping motor driver)

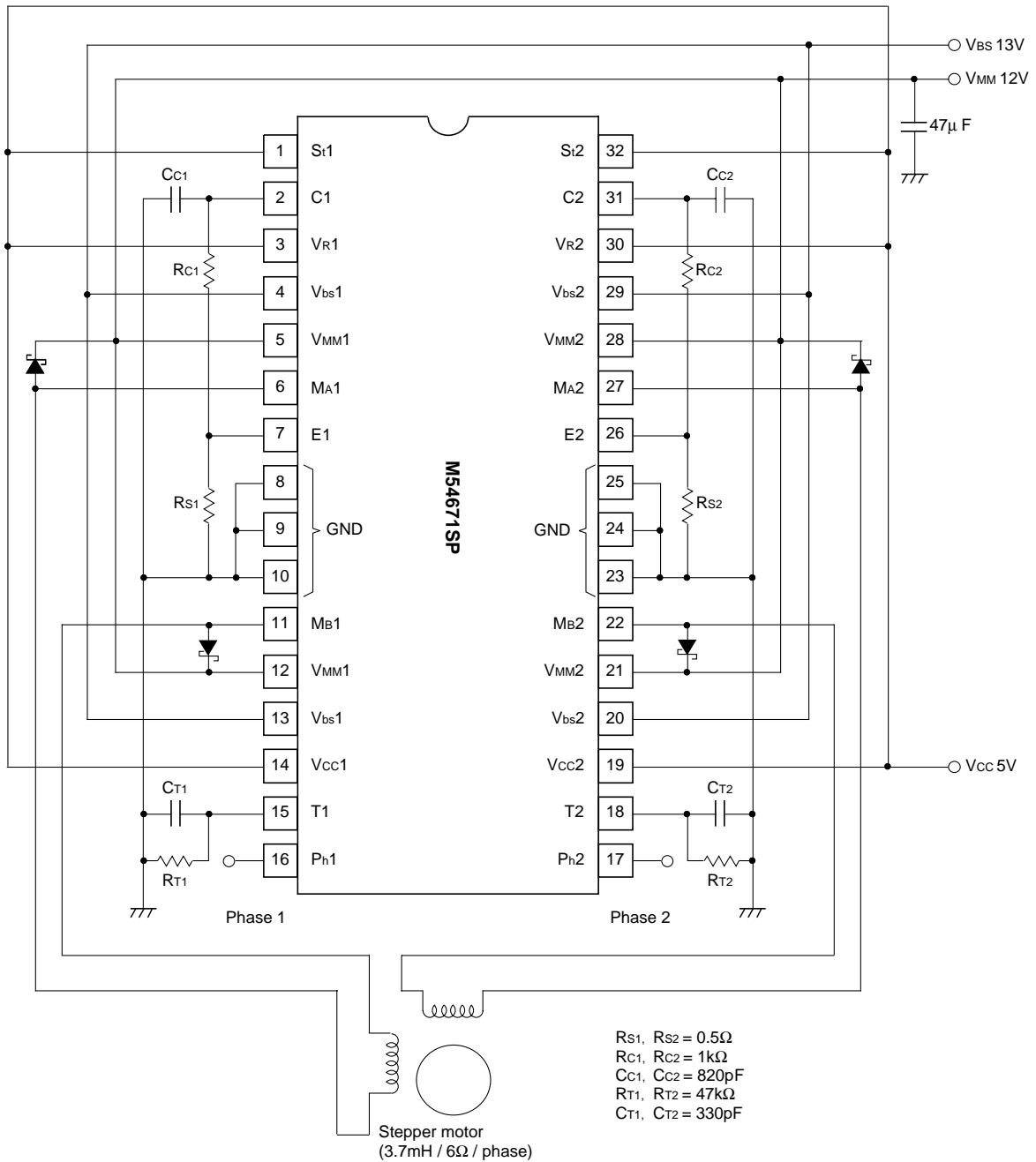

PRECAUTIONS FOR USE

- (1) Before use, never forget to short-circuit Vcc1 and Vcc2.
 - (2) When the whole output current changes by a large margin (for example, when thermal shutdown operation causes intermittent flow of output current), the supply voltage may undergo a change. Therefore, selection and wiring of power supply should be conducted cautiously to avoid such a situation that the supply voltage exceeds the absolute maximum ratings.
 - (3) When the supply voltage changes by a large margin, the operation of this IC may become unstable. In this case, the change of supply voltage can be controlled by connecting a capacitor between Vcc pin and GND pin.
 - (4) Thermal shutdown function
The state of thermal shutdown operation may differ according to the way of wiring within a board. Therefore, sufficient board evaluation should be conducted before use.
When the board is changed, operation on the replacing board should be evaluated.
The circuit board on which this IC is mounted is designed to realize low impedance between power supply and output pin. Therefore, it is desirable to take a safe measure such as fixing a fuse to avoid such a situation that the board is damaged by a fire when output pin is internally short-circuited by excessively applied surge voltage by accident.
 - (5) Flywheel
Flywheel diode is not built in this IC. Before use, connect a flywheel diode between each output (MA1, MB1, MA2, and MB2) and output power supply (VMM). (Refer to APPLICATION EXAMPLE.)
-