

## FEATURES

- 3.3V power supply
- PECL-to-TTL version of popular ECLinPS E111
- Guaranteed low skew specification
- Latched input
- Differential ECL internal design
- VBB output for single-ended operation
- Reset/enable
- Extra TTL and ECL power/ground pins
- Choice of ECL compatibility: MECL 10KH (10Hxxx) or 100K (100Hxxx)
- Available in 28-pin PLCC package

## DESCRIPTION

The SY10/100H641L are single supply, low skew translating 1:9 clock drivers. Devices in the Micrel-Synergy H600 translator series utilize the 28-lead PLCC for optimal power pinning, signal flow-through and electrical performance.

The devices feature a 24mA TTL output stage with AC performance specified into a 20pF load capacitance. A latch is provided on-chip. When LEN is LOW (or left open, in which case it is pulled LOW by the internal pull-downs), the latch is transparent. A HIGH on the enable pin (/EN) forces all outputs LOW.

The 10H version is compatible with MECL 10KH ECL logic levels. The 100H version is compatible with 100K levels.

## BLOCK DIAGRAM

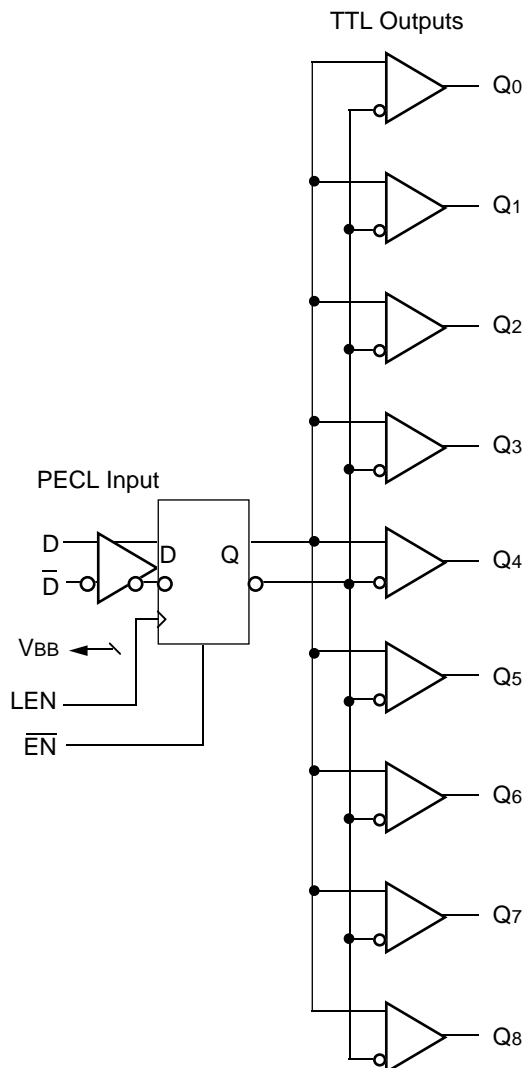

## PIN CONFIGURATION

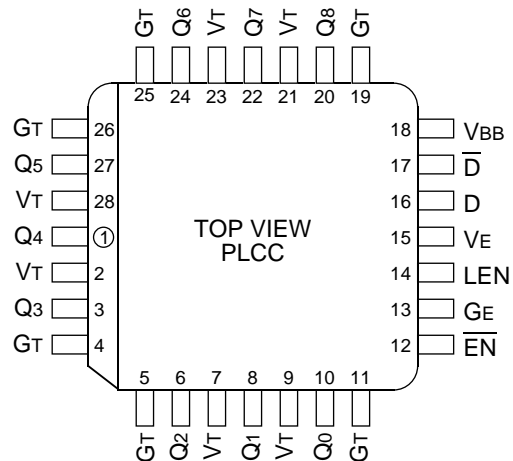

## PIN NAMES

Pin	Function
GT	TTL Ground (0V)
VT	TTL Vcc (+3.0V)
VE	ECL Vcc (+3.0V)
GE	ECL Ground (0V)
D, /D	Signal Input (PECL)
VBB	VBB Reference Output (PECL)
Q0 – Q8	Signal Outputs (TTL)
/EN	Enable Input (PECL)
LEN	Latch Enable Input (PECL)

## ABSOLUTE MAXIMUM RATINGS<sup>(1)</sup>

Symbol	Rating	Value	Unit
V <sub>E</sub> (ECL) V <sub>T</sub> (TTL)	Power Supply Voltage	-0.5 to +7.0 -0.5 to +7.0	V
V <sub>I</sub> (ECL)	Input Voltage	0.0 to V <sub>E</sub>	V
V <sub>OUT</sub> (TTL)	Disabled 3-State Output	0.0 to V <sub>T</sub>	V
I <sub>OUT</sub> (ECL)	Output Current - Continuous - Surge	50 100	mA
T <sub>store</sub>	Storage Temperature	-65 to +150	°C
T <sub>A</sub>	Operating Temperature	0 to +85	°C

**NOTE:**

- Do not exceed.

## TRUTH TABLE

D	LEN	/EN	Q
L	L	L	L
H	L	L	H
X	H	L	Q <sub>0</sub>
X	X	H	L

## DC ELECTRICAL CHARACTERISTICS

V<sub>T</sub> = V<sub>E</sub> = +3.0V to +3.6V

Symbol	Parameter	T <sub>A</sub> = 0°C		T <sub>A</sub> = +25°C		T <sub>A</sub> = +85°C		Unit	Condition	
		Min.	Max.	Min.	Max.	Min.	Max.			
I <sub>EE</sub>	Power Supply Current	ECL	—	30	—	30	—	30	mA	V <sub>E</sub> Pin
I <sub>CC</sub> H		TTL	—	30	—	30	—	30		Total all V <sub>T</sub> pins
I <sub>CC</sub> L		—	35	—	35	—	35			

## TTL DC ELECTRICAL CHARACTERISTICS

V<sub>T</sub> = V<sub>E</sub> = +3.0V to +3.6V

Symbol	Parameter	T <sub>A</sub> = 0°C		T <sub>A</sub> = +25°C		T <sub>A</sub> = +85°C		Unit	Condition
		Min.	Max.	Min.	Max.	Min.	Max.		
V <sub>OH</sub>	Output HIGH Voltage	2.0	—	2.0	—	2.0	—	V	I <sub>OH</sub> = -3.0mA
V <sub>OL</sub>	Output LOW Voltage	—	0.5	—	0.5	—	0.5	V	I <sub>OL</sub> = 24mA
I <sub>OS</sub>	Output Short Circuit Current	-100	—	-100	—	-100	—	mA	V <sub>OUT</sub> = 0V

## 10H ECL DC ELECTRICAL CHARACTERISTICS

V<sub>T</sub> = V<sub>E</sub> = +3.0V to +3.6V

Symbol	Parameter	T <sub>A</sub> = 0°C		T <sub>A</sub> = +25°C		T <sub>A</sub> = +85°C		Unit	Condition
		Min.	Max.	Min.	Max.	Min.	Max.		
I <sub>IH</sub>	Input HIGH Current	—	225	—	175	—	175	μA	—
I <sub>IL</sub>	Input LOW Current	0.5	—	0.5	—	0.5	—	μA	—
V <sub>IH</sub>	Input HIGH Voltage <sup>(1)</sup>	2.130	2.460	2.170	2.490	2.240	2.580	V	V <sub>E</sub> = 3.3V
V <sub>IL</sub>	Input LOW Voltage <sup>(1)</sup>	1.350	1.820	1.350	1.820	1.350	1.855	V	V <sub>E</sub> = 3.3V
V <sub>BB</sub>	Output Reference Voltage <sup>(1)</sup>	1.920	2.030	1.950	2.050	1.990	2.110	V	V <sub>E</sub> = 3.3V

**NOTE:**

- V<sub>IH</sub>, V<sub>IL</sub> and V<sub>BB</sub> are referenced to V<sub>E</sub> and will vary 1:1 with the power supply. The levels shown are for V<sub>E</sub> = +3.3V.

## 100H ECL DC ELECTRICAL CHARACTERISTICS

$V_T = V_E = +3.0V$  to  $+3.6V$

Symbol	Parameter	$T_A = 0^\circ C$		$T_A = +25^\circ C$		$T_A = +85^\circ C$		Unit	Condition
		Min.	Max.	Min.	Max.	Min.	Max.		
$I_{IH}$	Input HIGH Current	—	225	—	175	—	175	$\mu A$	—
$I_{IL}$	Input LOW Current	0.5	—	0.5	—	0.5	—	$\mu A$	—
$V_{IH}$	Input HIGH Voltage <sup>(1)</sup>	2.135	2.420	2.135	2.420	2.135	2.420	V	$V_E = 3.3V$
$V_{IL}$	Input LOW Voltage <sup>(1)</sup>	1.490	1.825	1.490	1.825	1.490	1.825	V	$V_E = 3.3V$
$V_{BB}$	Output Reference Voltage <sup>(1)</sup>	1.920	2.040	1.920	2.040	1.920	2.040	V	$V_E = 3.3V$

**NOTE:**

1.  $V_{IH}$ ,  $V_{IL}$  and  $V_{BB}$  are referenced to  $V_E$  and will vary 1:1 with the power supply. The levels shown are for  $V_E = +3.3V$ .

## AC ELECTRICAL CHARACTERISTICS

$V_T = V_E = +3.0V$  to  $+3.6V$

Symbol	Parameter	$T_A = 0^\circ C$		$T_A = +25^\circ C$		$T_A = +85^\circ C$		Unit	Condition
		Min.	Max.	Min.	Max.	Min.	Max.		
$t_{PLH}$ $t_{PHL}$	Propagation Delay D to Output	2.0 2.5	3.0 3.5	2.0 2.5	3.0 3.5	2.0 2.5	3.0 3.5	ns	$C_L = 20pF$
$t_{skpp}$	Part-to-Part Skew <sup>(1,4)</sup>	—	0.5	—	0.5	—	0.5	ns	$C_L = 20pF$
$t_{skew++}$ $t_{skew--}$	Within-Device Skew <sup>(2,3,4)</sup>	— —	0.3 <sup>(7)</sup> 0.35 <sup>(8)</sup>	— —	0.3 <sup>(7)</sup> 0.35 <sup>(8)</sup>	— —	0.3 <sup>(7)</sup> 0.35 <sup>(8)</sup>	ns ns	$C_L = 20pF$ $C_L = 20pF$
$t_{PLH}$ $t_{PHL}$	Propagation Delay LEN to Output	2.0	3.5	2.0	3.5	2.0	3.5	ns	$C_L = 20pF$
$t_{PLH}$ $t_{PHL}$	Propagation Delay /EN to Output	2.0	3.5	2.0	3.5	2.0	3.5	ns	$C_L = 20pF$
$t_r$ $t_f$	Output Rise/Fall Time 1.0V to 2.0V	— —	1.7 1.6	— —	1.7 1.6	— —	1.7 1.6	ns	$C_L = 20pF$
$f_{MAX}$	Maximum Input Frequency <sup>(5,6)</sup>	135	—	135	—	135	—	MHz	
—	Pulse Width	1.5	—	1.5	—	1.5	—	ns	—
—	Recovery Time	1.25	—	1.25	—	1.25	—	ns	—
$t_S$	Set-up Time	0.5 (typ.)		0.5 (typ.)		0.5 (typ.)		ns	—
$t_H$	Hold Time	0.5 (typ.)		0.5 (typ.)		0.5 (typ.)		ns	—

**NOTES:**

1. Device-to-Device Skew considering HIGH-to-HIGH transitions at common  $V_{CC}$  level.
2. Within-Device Skew considering HIGH-to-HIGH transitions at common  $V_{CC}$  level.
3. Within-Device Skew considering LOW-to-LOW transitions at common  $V_{CC}$  level.
4. All skew parameters are guaranteed but not tested.
5. Frequency at which output levels will meet a 0.8V to 2.0V minimum swing.
6. The  $f_{MAX}$  value is specified as the minimum guaranteed maximum frequency. Actual operational maximum frequency may be greater.
7.  $V_T = V_E = +3.15V$  to  $+3.45V$ , (i.e.  $V_E \pm 5\%$ ).
8.  $V_T = V_E = +3.0V$  to  $+3.6V$ , (i.e.  $V_E \pm 10\%$ ).

**TTL SWITCHING CIRCUIT**

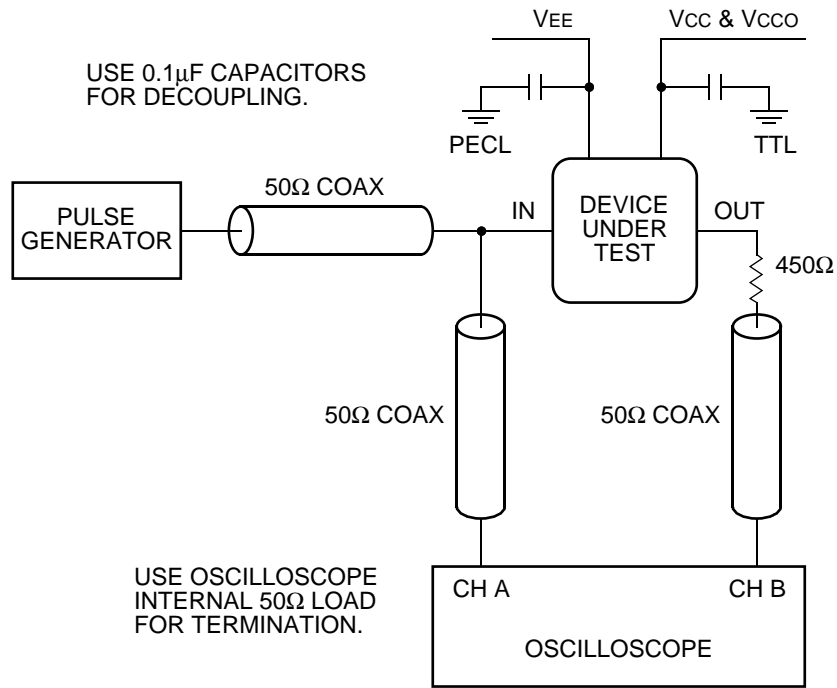

**ECL/TTL PROPAGATION DELAY — SINGLE ENDED**

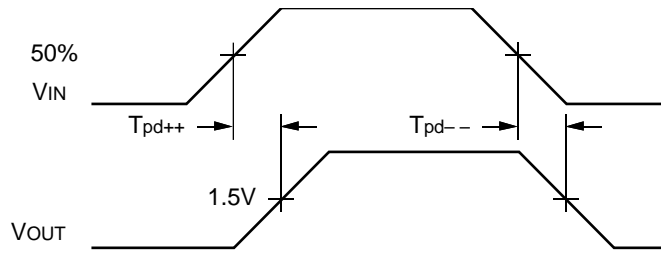

**ECL/TTL WAVEFORMS: RISE AND FALL TIMES**

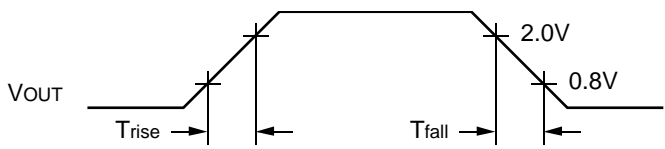

**PRODUCT ORDERING CODE**

Ordering Code	Package Type	Operating Range
SY10H641LC	J28-1	Commercial
SY10H641LJCTR	J28-1	Commercial
SY100H641LJC	J28-1	Commercial
SY100H641LJCTR	J28-1	Commercial

**28 LEAD PLCC (J28-1)**

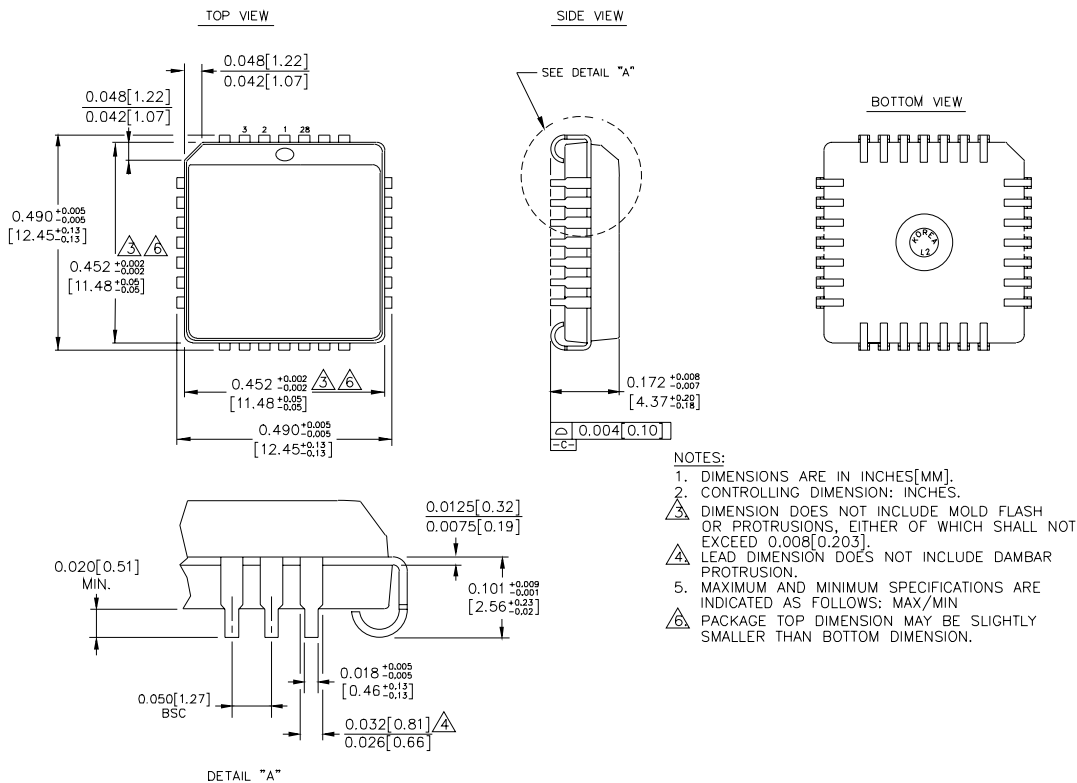

Rev. 03

**MICREL-SYNERGY 3250 SCOTT BOULEVARD SANTA CLARA CA 95054 USA**

TEL + 1 (408) 980-9191 FAX + 1 (408) 914-7878 WEB <http://www.micrel.com>

This information is believed to be accurate and reliable, however no responsibility is assumed by Micrel for its use nor for any infringement of patents or other rights of third parties resulting from its use. No license is granted by implication or otherwise under any patent or patent right of Micrel Inc.

© 2000 Micrel Incorporated