

Features

- High output power
- Low phase noise performance
- Frequency stability with temperature
- Frequency agility

Applications

- A low noise source for research use
- Autonomous Intelligent Cruise Control systems
- FMCW and Doppler radar systems
- Voltage controlled oscillator

Dynex Semiconductor has developed a low cost, state of the art Millimetre Wave Gunn diode based oscillator module that operates in the 75 to 80 GHz band, with a 1 GHz operational bandwidth.

The initial application of the oscillator is within an automotive product.

The use of Gunn technology provides performance advantages compared to competing technologies.

The Gunn diode is a custom MBE grown GaAs heterojunction device incorporated into a machined alloy body with an integral custom waveguide 26 flange. The oscillator is a radial mode 2nd harmonic bias tuned design.

For microstrip applications a waveguide to 0.18mm microstrip step transition is available to interface the oscillator to microstrip circuits.

A separate power supply driver PCB can be provided to interface to the Gunn module. This provides over voltage, spike and reverse polarity protection. The driver PCB also allows ease of frequency setting or the application of modulation.

It should be noted that the Gunn diode is easily damaged by voltage transients or reverse bias. It is recommended that the driver circuitry is always used to protect the Gunn diode from potential damage.

Frequency adjustment or modulation of the oscillator is achieved by changing the oscillator bias supply via the driver PCB. The driver PCB provides a control voltage input for this purpose. The voltage limits must be within those specified

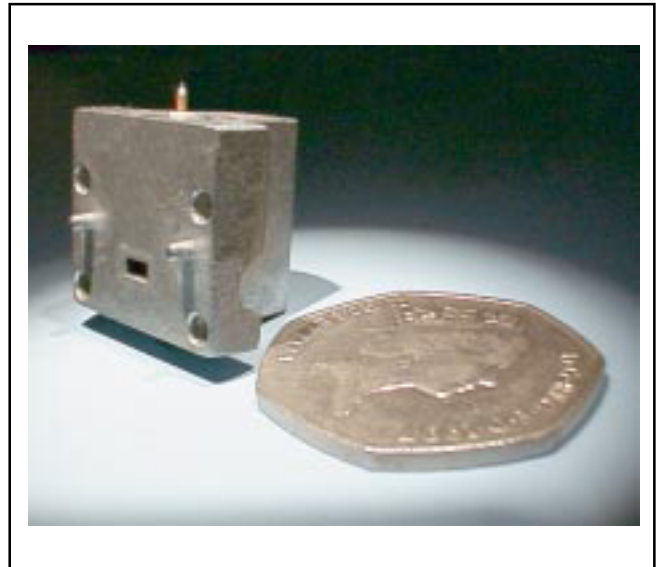

Figure 1 Millimeter Wave Gunn Oscillator Module

It is possible to extend the lower operational temperature range of the oscillator by applying a small DC voltage to the oscillator. This voltage is insufficient to generate any RF power.

The required frequency range must be specified when ordering the parts.

Specification

Potential operating frequency range	75 - 80 GHz
Microwave Output power (@25 C)	+16 dBm min.
SSB Phase Noise (100kHz offset)	-85 dBc/Hz typ.
Operating voltage range	5.0 - 6.5 V
Supply current	750 mA typ.
P/ T (max.)	0.35 mW/• C
F/ T (typ.)	1 - 2 MHz/• C
Voltage pushing	400 - 800 MHz/V
Operational temperature range	-30 C to +85 C
Weight (Oscillator only)	25 g approx.

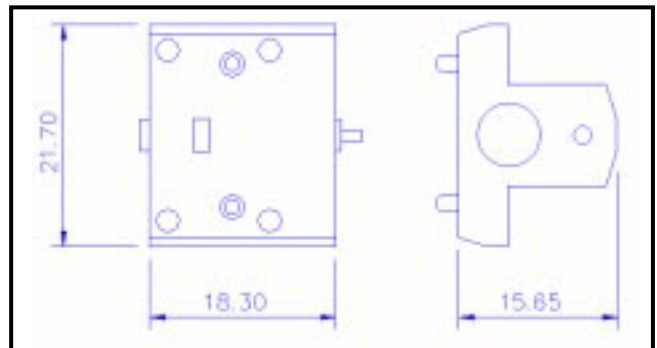



<http://www.dynexsemi.com>

e-mail: auto_solutions@dynexsemi.com

HEADQUARTERS OPERATIONS
DYNEX SEMICONDUCTOR LTD
Doddington Road, Lincoln.
Lincolnshire. LN6 3LF. United Kingdom.
Tel: 00-44-(0)1522-500500
Fax: 00-44-(0)1522-500550

CUSTOMER SERVICE
Tel: +44 (0)1522 502934. Fax: +44 (0)1522 502773

© Dynex Semiconductor 2002
TECHNICAL DOCUMENTATION – NOT FOR RESALE. PRODUCED IN UNITED KINGDOM

Datasheet Annotations:

Dynex Semiconductor annotate datasheets in the top right hand corner of the front page, to indicate product status. The annotations are as follows:-

Target Information: This is the most tentative form of information and represents a very preliminary specification. No actual design work on the product has been started.

Preliminary Information: The product is in design and development. The datasheet represents the product as it is understood but details may change.

Advance Information: The product design is complete and final characterisation for volume production is well in hand.

No Annotation: The product parameters are fixed and the product is available to datasheet specification.

This publication is issued to provide information only which (unless agreed by the Company in writing) may not be used, applied or reproduced for any purpose nor form part of any order or contract nor to be regarded as a representation relating to the products or services concerned. No warranty or guarantee express or implied is made regarding the capability, performance or suitability of any product or service. The Company reserves the right to alter without prior notice the specification, design or price of any product or service. Information concerning possible methods of use is provided as a guide only and does not constitute any guarantee that such methods of use will be satisfactory in a specific piece of equipment. It is the user's responsibility to fully determine the performance and suitability of any equipment using such information and to ensure that any publication or data used is up to date and has not been superseded. These products are not suitable for use in any medical products whose failure to perform may result in significant injury or death to the user. All products and materials are sold and services provided subject to the Company's conditions of sale, which are available on request.

All brand names and product names used in this publication are trademarks, registered trademarks or trade names of their respective owners.