

Radiation Hardened Quad Differential Line Driver

Intersil's Satellite Applications Flow™ (SAF) devices are fully tested and guaranteed to 100kRAD total dose. These QML Class T devices are processed to a standard flow intended to meet the cost and shorter lead-time needs of large volume satellite manufacturers, while maintaining a high level of reliability.

The Intersil HS-26CT31RH-T is a Quad Differential Line Driver designed for digital data transmission over balanced lines and meets the requirements of EIA Standard RS-422. Radiation Hardened CMOS processing assures low power consumption, high speed, and reliable operation in the most severe radiation environments.

The HS-26CT31RH-T accepts TTL inputs and converts them to RS-422 compatible outputs. This circuit uses special outputs that enable the drivers to power down without loading down the bus. Enable and disable pins allow several devices to be connected to the same data source and addressed independently.

Specifications

Specifications for Rad Hard QML devices are controlled by the Defense Supply Center in Columbus (DSCC). The SMD numbers listed below must be used when ordering.

Detailed Electrical Specifications for the HS-26CT31RH-T are contained in SMD 5962-95632. A "hot-link" is provided from our website for downloading.

www.intersil.com/spacedefense/newsafclasst.asp

Intersil's Quality Management Plan (QM Plan), listing all Class T screening operations, is also available on our website.

www.intersil.com/quality/manuals.asp

Ordering Information

ORDERING NUMBER	PART NUMBER	TEMP. RANGE (°C)
5962R9563201TEC	HS1-26CT31RH-T	-55 to 125
HS1-26C31RH/Proto	HS1-26C31RH/Proto	-55 to 125
5962R9563201TXC	HS9-26C31RH-T	-55 to 125
HS9-26C31RH/Proto	HS9-26C31RH/Proto	-55 to 125

NOTE: **Minimum order quantity for -T is 150 units through distribution, or 450 units direct.**

Features

- QML Class T, Per MIL-PRF-38535
- Radiation Performance
 - Gamma Dose 1×10^5 RAD(Si)
 - SEU and SEL Immune to 100MeV/mg/cm²
- EIA RS-422 Compatible Outputs (Except for IOS)
- TTL Compatible Inputs
- High Impedance Outputs when Disabled or Powered Down
- Low Power Dissipation 2.75mW Standby (Max)
- Single 5V Supply
- Low Output Impedance 10Ω or Less
- Full -55°C to 125°C Military Temperature Range

Pinouts

HS1-26CT31RH-T (SBDIP), CDIP2-T16
TOP VIEW

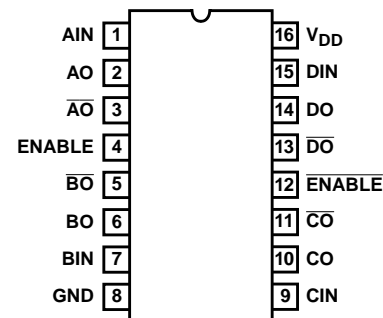

HS9-26CT31RH-T (FLATPACK), CDFP4-F16
TOP VIEW

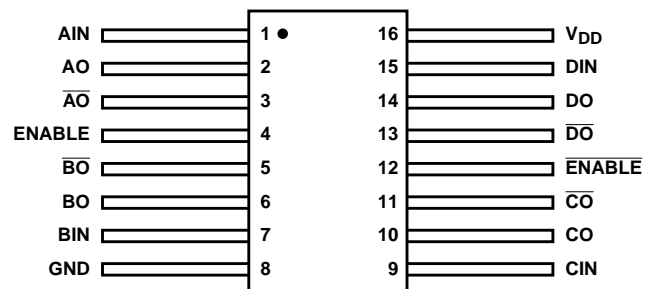

Functional Diagram

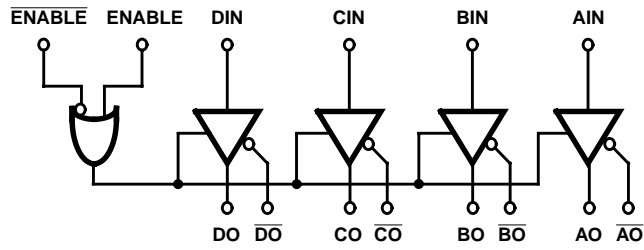

TRUTH TABLE

DEVICE POWER ON/OFF	INPUTS			OUTPUT	
	ENABLE	$\overline{\text{ENABLE}}$	IN	OUT	$\overline{\text{OUT}}$
ON	0	1	X	HI-Z	HI-Z
ON	1	X	0	0	1
ON	X	0	0	0	1
ON	1	X	1	1	0
ON	X	0	1	1	0
OFF (0V)	X	X	X	HI-Z	HI-Z

Die Characteristics

DIE DIMENSIONS:

2450 μ m x 4950 μ m x 533 μ m \pm 25.4 μ m
(97 x 195 x 21 mils \pm 1 mil)

METALLIZATION:

M1: Mo/Tiw
Thickness: 5800 \AA
M2: Al/Si/Cu
Thickness: 10k \AA \pm 1k \AA

SUBSTRATE POTENTIAL:

Internally connected to V_{DD}.
May be left floating.

BACKSIDE FINISH:

Silicon

PASSIVATION:

Type: SiO₂
Thickness: 8k \AA \pm 1k \AA

WORST CASE CURRENT DENSITY:

< 2.0e5 A/cm²

TRANSISTOR COUNT:

285

PROCESS:

Radiation Hardened CMOS, AVLSI

Metallization Mask Layout

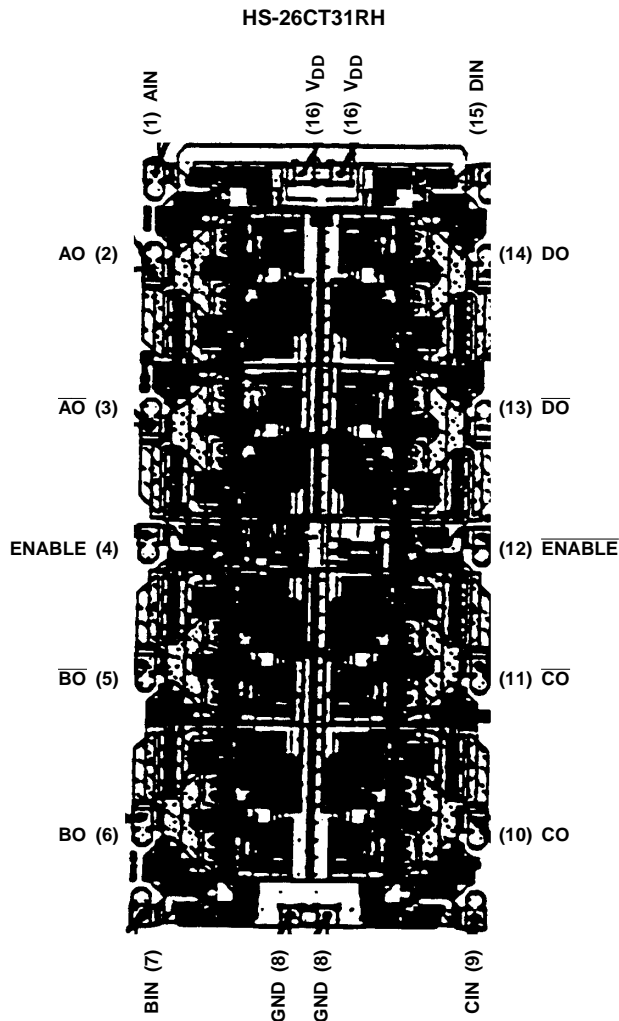

All Intersil semiconductor products are manufactured, assembled and tested under **ISO9000** quality systems certification.

Intersil semiconductor products are sold by description only. Intersil Corporation reserves the right to make changes in circuit design and/or specifications at any time without notice. Accordingly, the reader is cautioned to verify that data sheets are current before placing orders. Information furnished by Intersil is believed to be accurate and reliable. However, no responsibility is assumed by Intersil or its subsidiaries for its use; nor for any infringements of patents or other rights of third parties which may result from its use. No license is granted by implication or otherwise under any patent or patent rights of Intersil or its subsidiaries.

For information regarding Intersil Corporation and its products, see web site <http://www.intersil.com>