

**IN74LS157**

**Quad 2-Input Data Selector/Multiplexer**

This monolithic data selector/multiplexer contains inverters and drivers to supply full on-chip data selection to the four output gates. A separate strobe input is provided. A 4-bit word is selected from one of two sources and is routed to the four outputs. The LS157 has the same functions and pin connections as the LS257 but the latter is provided with 3-state outputs.

- Buffered Inputs and Outputs
- Common Strobe/Select input for all 4 circuits

**N SUFFIX PLASTIC**

**D SUFFIX SOIC**

**ORDERING INFORMATION**  
 IN74LS157N Plastic  
 IN74LS157D SOIC  
 $T_A = 0^\circ$  to  $70^\circ$  C for all packages

**LOGIC DIAGRAM**

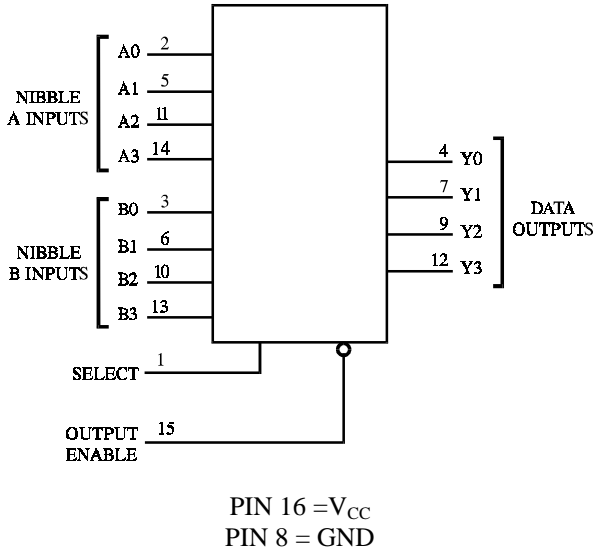

**PIN ASSIGNMENT**

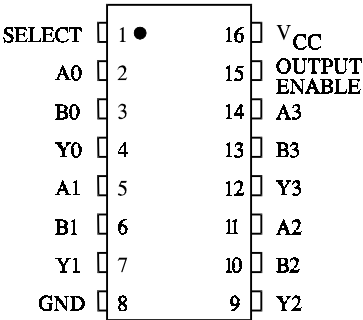

**FUNCTION TABLE**

Inputs		Outputs
Output Enable	Select	Y0-Y3
H	X	L
L	L	A0-A3
L	H	B0-B3

X=don't care  
 A0-A3,B0-B3=the levels of the respective Data-Word Inputs

**MAXIMUM RATINGS\***

Symbol	Parameter	Value	Unit
V <sub>CC</sub>	Supply Voltage	7.0	V
V <sub>IN</sub>	Input Voltage	7.0	V
V <sub>OUT</sub>	Output Voltage	5.5	V
T <sub>stg</sub>	Storage Temperature Range	-65 to +150	°C

\*Maximum Ratings are those values beyond which damage to the device may occur. Functional operation should be restricted to the Recommended Operating Conditions.

**RECOMMENDED OPERATING CONDITIONS**

Symbol	Parameter	Min	Max	Unit
V <sub>CC</sub>	Supply Voltage	4.75	5.25	V
V <sub>IH</sub>	High Level Input Voltage	2.0		V
V <sub>IL</sub>	Low Level Input Voltage		0.8	V
I <sub>OH</sub>	High Level Output Current		-0.4	mA
I <sub>OL</sub>	Low Level Output Current		8.0	mA
T <sub>A</sub>	Ambient Temperature Range	0	+70	°C

**DC ELECTRICAL CHARACTERISTICS** over full operating conditions

Symbol	Parameter	Test Conditions	Guaranteed Limit		Unit
			Min	Max	
V <sub>IK</sub>	Input Clamp Voltage	V <sub>CC</sub> = min, I <sub>IN</sub> = -18 mA		-1.5	V
V <sub>OH</sub>	High Level Output Voltage	V <sub>CC</sub> = min, I <sub>OH</sub> = -0.4 mA	2.7		V
V <sub>OL</sub>	Low Level Output Voltage	V <sub>CC</sub> = min, I <sub>OL</sub> = 4 mA		0.4	V
		V <sub>CC</sub> = min, I <sub>OL</sub> = 8 mA		0.5	
I <sub>IH</sub>	High Level Input Current	V <sub>CC</sub> = max V <sub>IN</sub> = 2.7 V	for pins 1,15	40	μA
			A or B input	20	
		V <sub>CC</sub> = max V <sub>IN</sub> = 7.0 V	for pins 1,15	0.2	mA
A or B input	0.1				
I <sub>IL</sub>	Low Level Input Current	V <sub>CC</sub> = max V <sub>IN</sub> = 0.4 V	for pins 1,15	-0.8	mA
			A or B input	-0.4	
I <sub>O</sub>	Output Short Circuit Current	V <sub>CC</sub> = max, V <sub>O</sub> = 0 V (Note 1)	-20	-100	mA
I <sub>CC</sub>	Supply Current	V <sub>CC</sub> = max (Note 2)		16	mA

Note 1: Not more than one output should be shorted at a time, and the duration should not exceed one second.

Note 2: I<sub>CC</sub> is measured with all outputs open, and 4.5 V applied to all inputs.

**AC ELECTRICAL CHARACTERISTICS** ( $T_A=25^\circ\text{C}$ ,  $V_{CC} = 5.0\text{ V}$ ,  $C_L = 15\text{ pF}$ ,  $R_L = 2\text{ k}\Omega$ ,  $t_r=15\text{ ns}$ ,  $t_f = 6.0\text{ ns}$ )

Symbol	Parameter	Min	Max	Unit
$t_{PLH}$	Propagation Delay, Input A or B to Output Y		14	ns
$t_{PHL}$	Propagation Delay, Input A or B to Output Y		14	ns
$t_{PLH}$	Propagation Delay, Select to Output Y		23	ns
$t_{PHL}$	Propagation Delay, Select to Output Y		27	ns
$t_{PLH}$	Propagation Delay, Output Enable to Output Y		20	ns
$t_{PHL}$	Propagation Delay, Output Enable to Output Y		21	ns

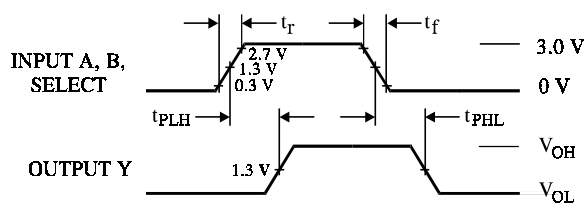

Figure 1. Switching Waveforms

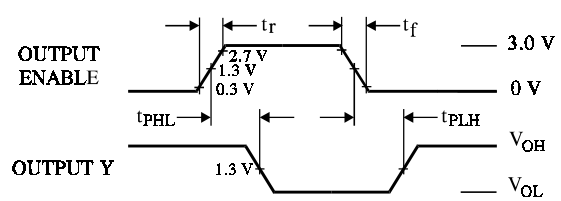
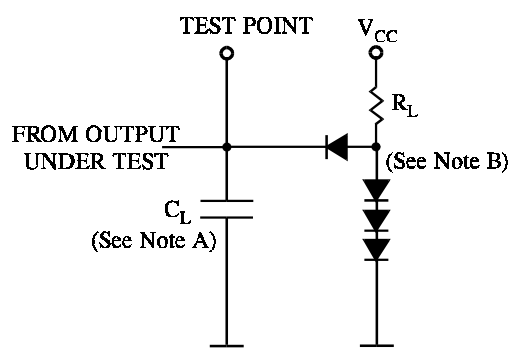

Figure 2. Switching Waveforms



NOTES A.  $C_L$  includes probe and jig capacitance.  
 B. All diodes are 1N916 or 1N3064.

Figure 3. Test Circuit