

Control IC for Switched Mode Power Supplies using MOS Transistors

The IC ILA 4605-2 controls the MOS - power transistor and performs all necessary regulation and monitoring function in free running flyback converters. Because of the fact that a wide load range is achieved, this IC is applicable for consumer as well as industrial power supplies.

The serial circuit and primary winding of the flyback transformer are connected in series to the input voltage. During the switch - on period of the transistor, energy is stored in the transformer. During the switch - off period the energy is fed to the load via the secondary winding. By varying switch - on time of the Power transistor, the IC controls each portion of energy transferred to the secondary side such that the output voltage remains nearly independent of load variations. The required control information is taken from the input voltage during the switch - on period and from a regulation winding during the switch - off period. A new cycle will start if the transformer has transferred the stored energy completely into the load.

FEATURES:

- Fold - back characteristics provides overload protection for external components
- Burst operation under secondary short - circuit condition implemented
- Protection against open or short of the control loop
- Switch - off if line voltage is too low (undervoltage switch - off)
- Line voltage depending compensation of fold - back point
- Soft start for quiet start - up without noise generated by the transformer
- Chip - over temperature protection (thermal shutdown)
- On - chip ringing suppression circuit against parasitic oscillations of the transformer

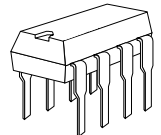

P-DIP-8-1

In the different voltage ranges the switched - mode Power supply (SMPS) behaves as follow:

No load operation. The Power supply is operating in the burst mode at typical 20 to 40 kHz. The output voltage can be a little bit higher or lower than the nominal value depending on the design of the transformer and the resistors of the control voltage divider.

Nominal operation. The switching frequency is reduced with increasing load and decreasing AC voltage. The duty factor primarily depends on the AC voltage. The output voltage is only depends on the load.

Overload point. Maximum output Power is available at this point of the output characteristic.

Overload. The energy transferred per operation cycle is limited at the top. Therefore the output voltages declines by secondary overloading.

PIN DEFINITION

Pin #	Function
1.	Information Input Concerning Secondary Voltage
2.	Information Input Regarding the Primary Current
3.	Input for Primary Voltage Monitoring
4.	Ground
5.	Output
6.	Supply Voltage Input
7.	Input for Soft Start and Integrator Circuit
8.	Input for the Feedback of the Oscillator

Block Diagram

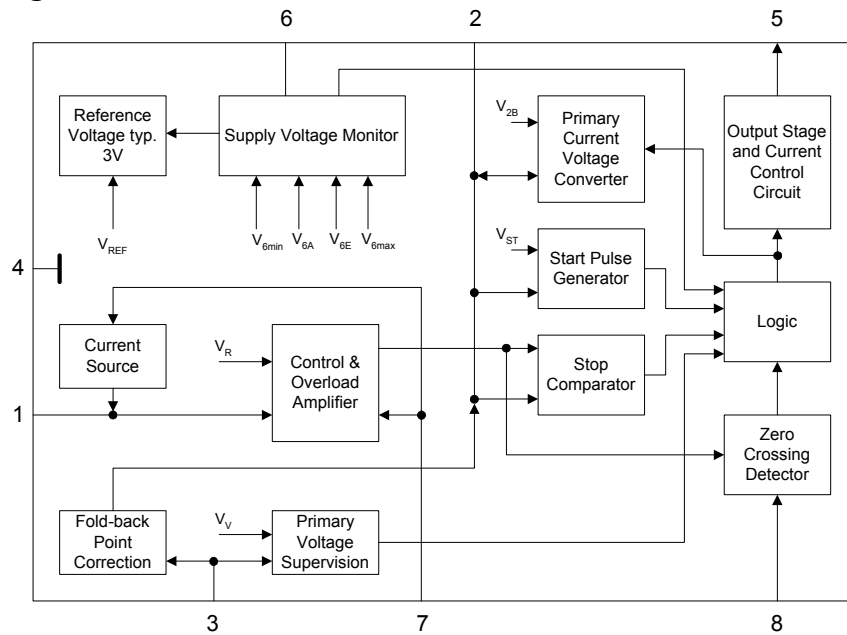

ABSOLUTE MAXIMUM RATINGS

Ta=-20 to 85°C; all voltages relatives to V_{pp}

Parameter	Symbol	Limit Values		Unit	Notes		
		min	max				
Voltages	pin 1	V ₁	-0.3	3	V	Supply voltage	
	pin 2	V ₂	-0.3		V		
	pin 3	V ₃	-0.3		V		
	pin 4	V ₄	-0.3		V		
	pin 5	V ₅	-0.3	V ₆	V		
	pin 6	V ₆	-0.3	20	V		
	pin 7	V ₇	-0.3		V		
Current	pin 1	I ₁		3	mA	t _p ≤50μs; v≤0.1 * t _p ≤50μs; v≤0.1 t _p ≤50μs; v≤0.1	
	pin 2	I ₂		3	mA		
	pin 3	I ₃		3	mA		
	pin 4	I ₄	-1.5				A
	pin 5	I ₅	-0.5	1.5			A
	pin 6	I ₆		0.5			A
	pin 7	I ₇		3			mA
	pin 8	I ₈	-5	3			mA
Junction temperature	T _j			125	°C		
Storage temperature	T _{stg}			-40	125	°C	

Operating Range

Supply voltage	V ₆	7.5	15.5	V	IC is on
Ambient temperature	T _a	-20	85	°C	

* t_p= pulse width

v = duty circle

ILA4605-2

CHARACTERISTICS

Ta=25°C; V_S=10V

Parameter	Symbol	Limit Values		Units	Test Condition
		min.	max.		
Start - Up Hysteresis					
Start-up current drain	I _{6EO}		1.6	mA	V ₆ =V _{6E}
Switch-on voltage	V _{6E}	11	13	V	
Switch-on current	I _{6E1}		16	mA	V ₆ =V _{6E}
Voltage Clamp (V₆=10V; IC is off)					
At pins 2,3 (V ₆ ≤V _{6E})	V _{max}	5.6	9.0	V	I _{2,3} =1mA
Control Range					
Control input voltage	V _{1R}	370	430	mV	
Voltage gain of the control circuit in the control value	-V _R	150			
Push-Pull Output Stage					
Saturation voltages					
Pin 5 sourcing	V _{sat0}		2.2	V	I ₅ =-0.1A
Pin5 sinking	V _{satV}		1.4	V	I ₅ =+0.1A
Protection Circuit					
Undervoltage protection for V ₆ : voltage at pin 5 = V _{5min} if V ₆ < V _{6min}	V _{6min}	6	8	V	
Undervoltage protection for V ₆ : voltage at pin 5 = V _{5min} if V ₆ > V _{6max}	V _{6max}		16.7	V	

APPLICATION DIAGRAM

