

LDMOS Field Effect Transistor

60 W, DCS/PCS Band

1805–1880 MHz, 1930–1990 MHz

Description

The PTF180601 is a 60 W, internally matched *GOLDMOS* FET intended for EDGE applications in the DCS/PCS Band. Full gold metallization ensures excellent device lifetime and reliability.

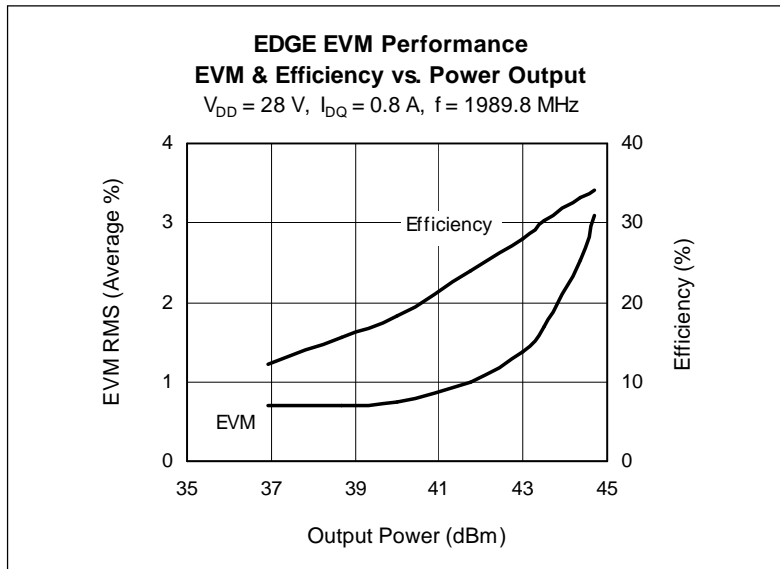

Features

- Broadband internal matching
- Typical two-tone performance
 - Average output power = 30 W
 - Gain = 16.5 dB
 - Efficiency = 35%
- Typical CW performance
 - Output power at P-1dB = 75 W
 - Gain = 15.5 dB
 - Efficiency = 47%
- Integrated ESD protection: Human Body Model, Class 1 (minimum)
- Excellent thermal stability
- Low HCI Drift
- Capable of handling 10:1 VSWR @ 28 V, 60 W (CW) output power

PTF180601C
Package 21248



PTF180601E
Package 30248



ESD: Electrostatic discharge sensitive device — observe handling precautions!

RF Characteristics at T_{CASE} = 25°C unless otherwise indicated

EDGE Measurements (not subject to production test—verified by design/characterization in Infineon test fixture)

V_{DD} = 28 V, I_{DQ} = 800 mA, P_{OUT} = 22 W, f = 1989.8 MHz

Characteristic	Symbol	Min	Typ	Max	Units
Error Vector Magnitude	EVM (RMS)	—	1.7	—	%
Modulation Spectrum @ 400 KHz	ACPR	—	-60	—	dBc
Modulation Spectrum @ 600 KHz	ACPR	—	-73	—	dBc
Gain	G _{ps}	—	16.5	—	dB
Drain Efficiency	η _D	—	32	—	%

Two-Tone Measurements (tested in Infineon test fixture)

V_{DD} = 28 V, I_{DQ} = 800 mA, P_{OUT} = 60 W PEP, f = 1930 MHz, Tone Spacing = 1 MHz

Characteristic	Symbol	Min	Typ	Max	Units
Gain	G _{ps}	15	16.5	—	dB
Drain Efficiency	η _D	30	35	—	%
Intermodulation Distortion	IMD	—	-30	-28	dBc

Electrical Characteristics at $T_{CASE} = 25^{\circ}C$ unless otherwise indicated

Characteristic	Conditions	Symbol	Min	Typ	Max	Units
Drain–Source Breakdown Voltage	$V_{GS} = 0 V, I_{DS} = 10 \mu A$	$V_{(BR)DSS}$	65	—	—	V
Drain Leakage Current	$V_{DS} = 28 V, V_{GS} = 0 V$	I_{DSS}	—	—	1.0	μA
On–State Resistance	$V_{GS} = 10 V, V_{DS} = 0.1 V$	$R_{DS(on)}$	—	0.135	—	Ω
Operating Gate Voltage	$V_{DS} = 28 V, I_{DQ} = 800 mA$	V_{GS}	2.5	3.2	4.0	V
Gate Leakage Current	$V_{GS} = 10 V, V_{DS} = 0 V$	I_{GSS}	—	0.01	1.0	μA

Maximum Ratings

Parameter		Symbol	Value	Unit
Drain–Source Voltage		V_{DSS}	65	V
Gate–Source Voltage		V_{GS}	–0.5 to +12	V
Junction Temperature		T_J	200	$^{\circ}C$
Total Device Dissipation	PTF180601C	P_D	159	W
Above 25 $^{\circ}C$ derate by			0.91	W/ $^{\circ}C$
Total Device Dissipation	PTF180601E	P_D	180	W
Above 25 $^{\circ}C$ derate by			1.03	W/ $^{\circ}C$
Storage Temperature Range		T_{STG}	–40 to +150	$^{\circ}C$
Thermal Resistance	PTF180601C	$R_{\theta JC}$	1.1	$^{\circ}C/W$
($T_{CASE} = 70^{\circ}C, 60 W CW$)	PTF180601E		0.97	$^{\circ}C/W$

Typical Performance (measurements taken in production test fixture, at $T_{CASE} = 25^{\circ}C$ unless otherwise indicated)

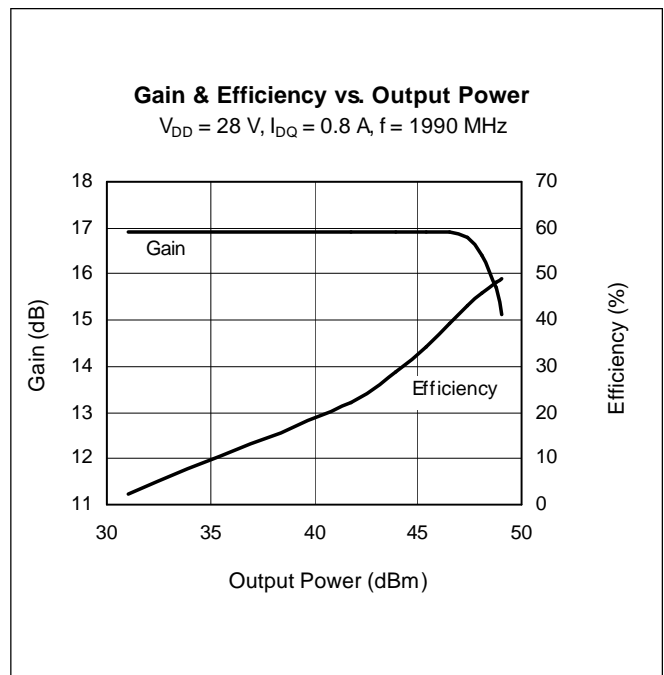
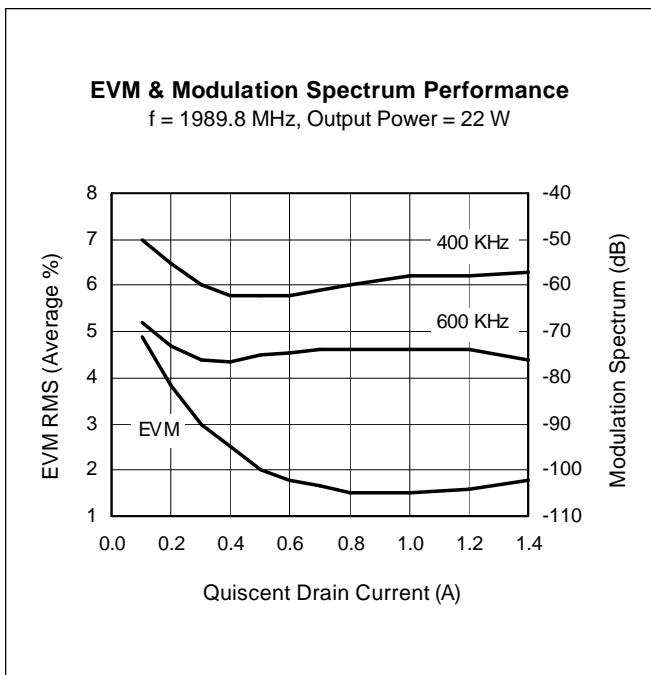
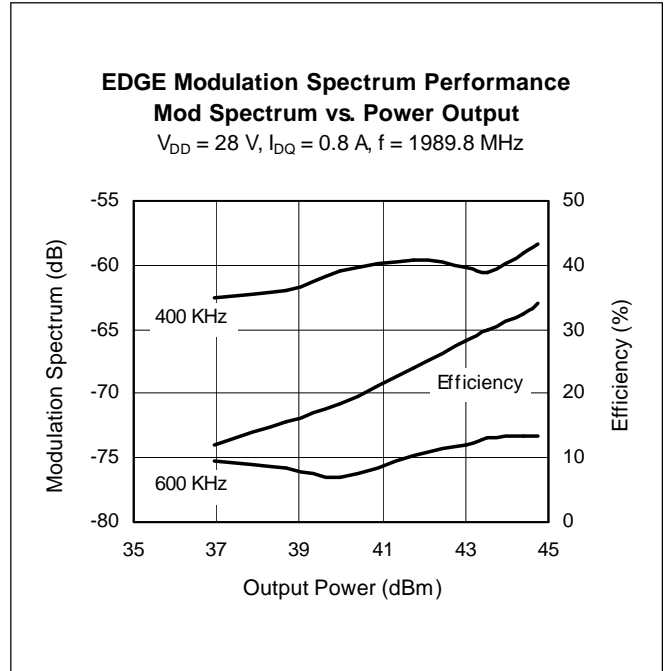
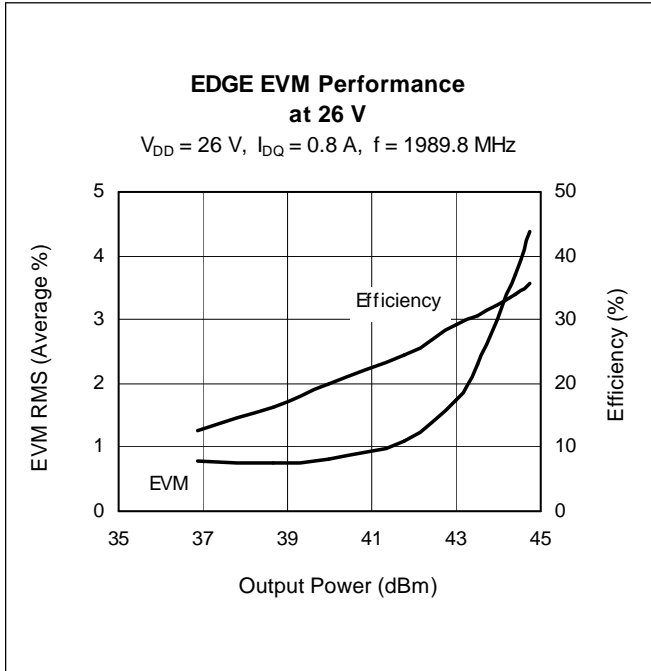

Typical Performance (cont.)

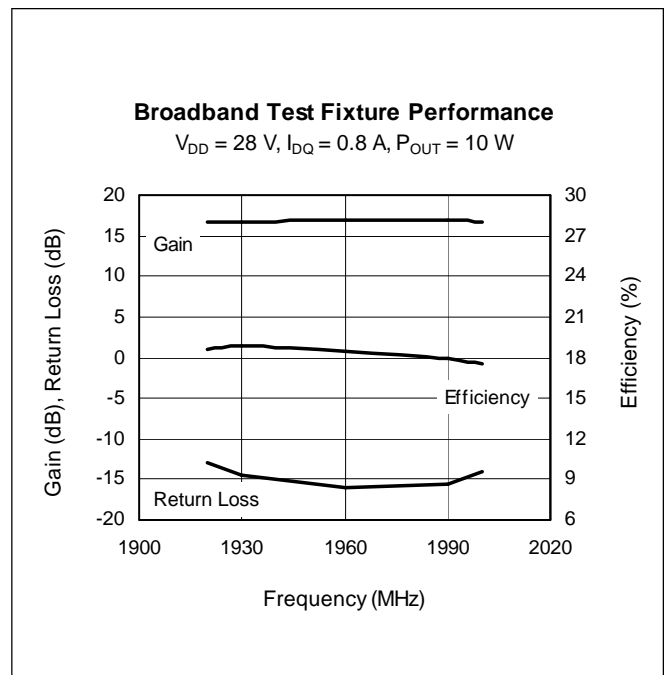
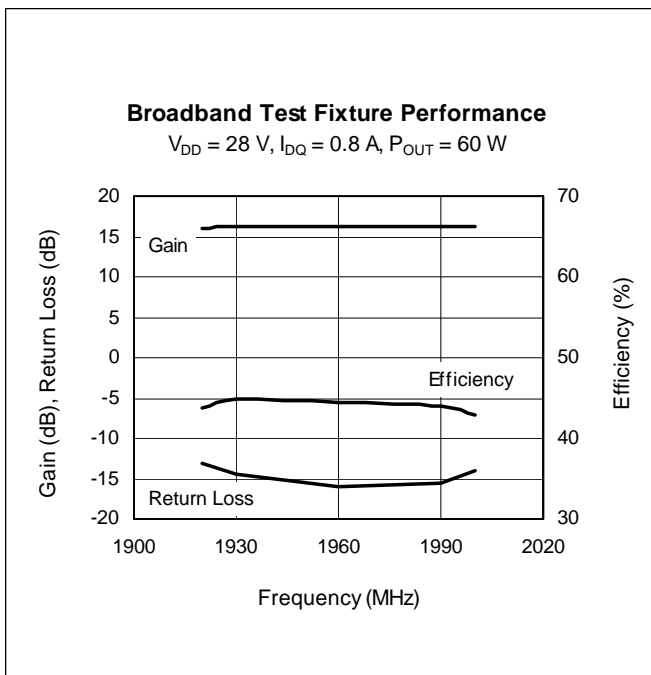
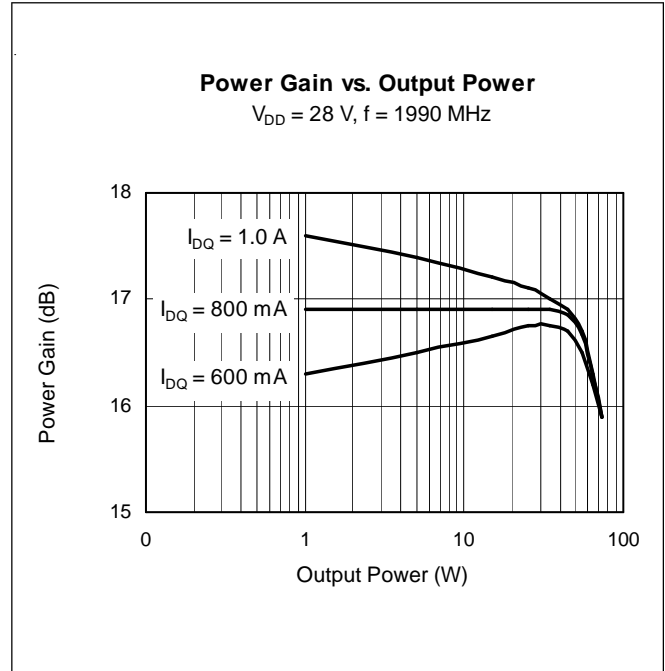
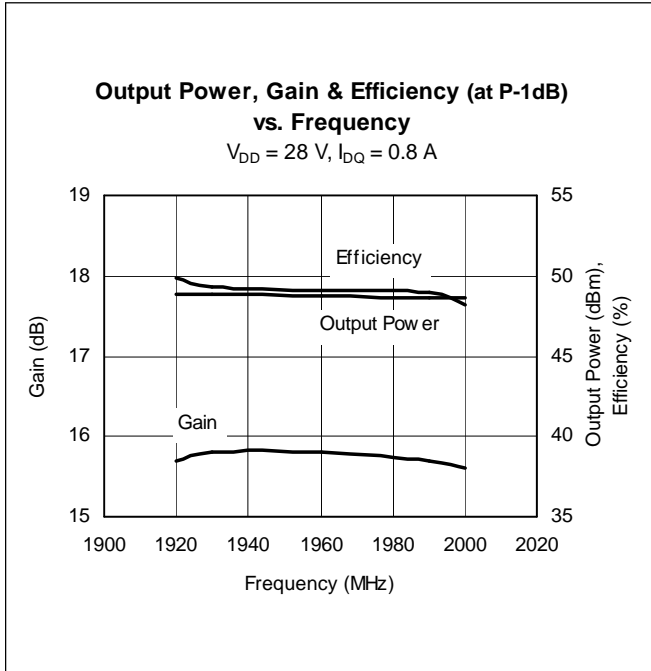

Typical Performance (cont.)

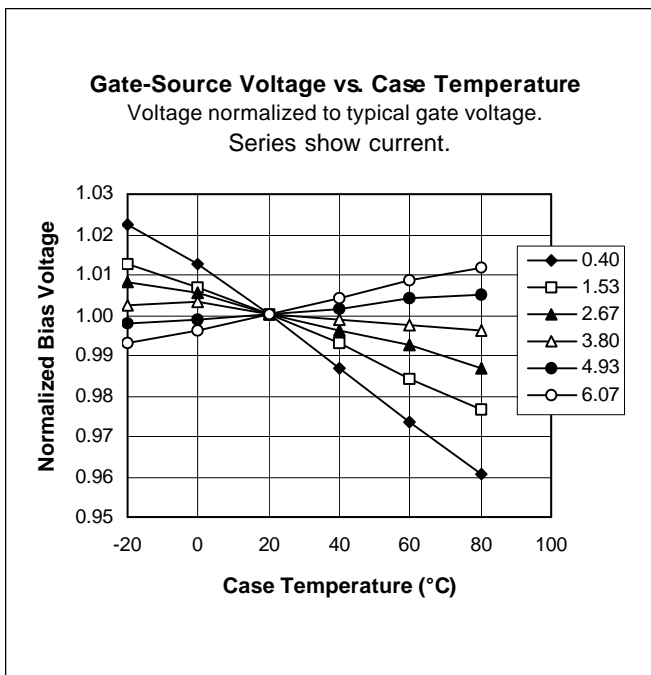
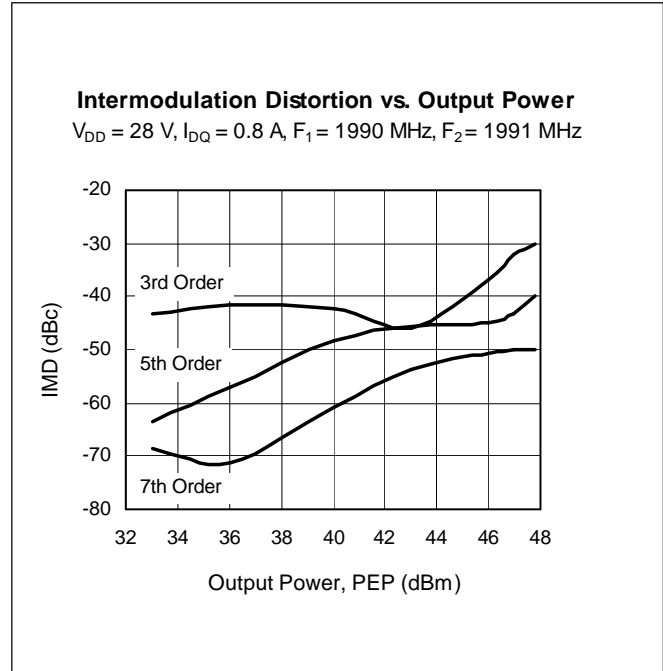
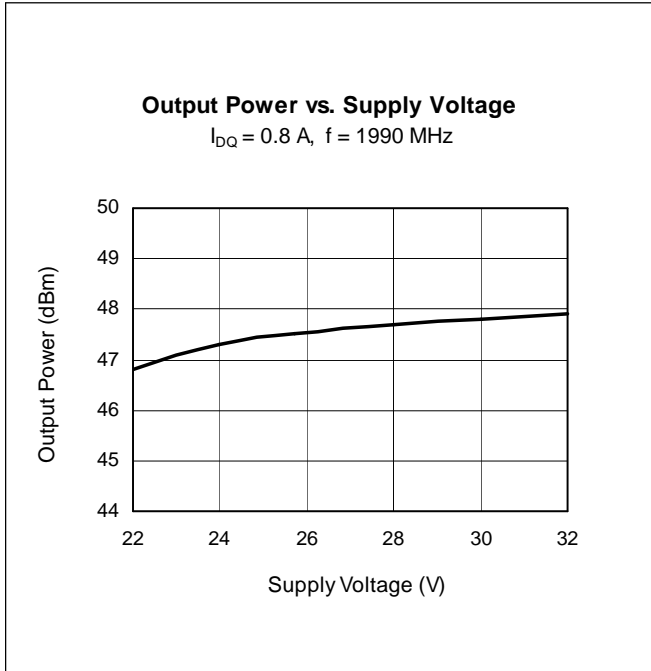

Broadband Circuit Impedance Data

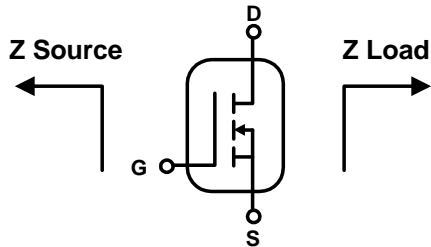

Frequency MHz	Z Source Ω		Z Load Ω	
	R	jX	R	jX
1900	9.9	0.55	3.7	4.1
1920	10.3	0.56	3.6	4.3
1930	10.3	0.50	3.5	4.3
1960	10.7	0.23	3.2	4.5
1990	11.0	-0.15	3.0	4.7
2000	11.1	-0.30	2.9	4.8
2020	11.3	-0.58	2.7	5.0

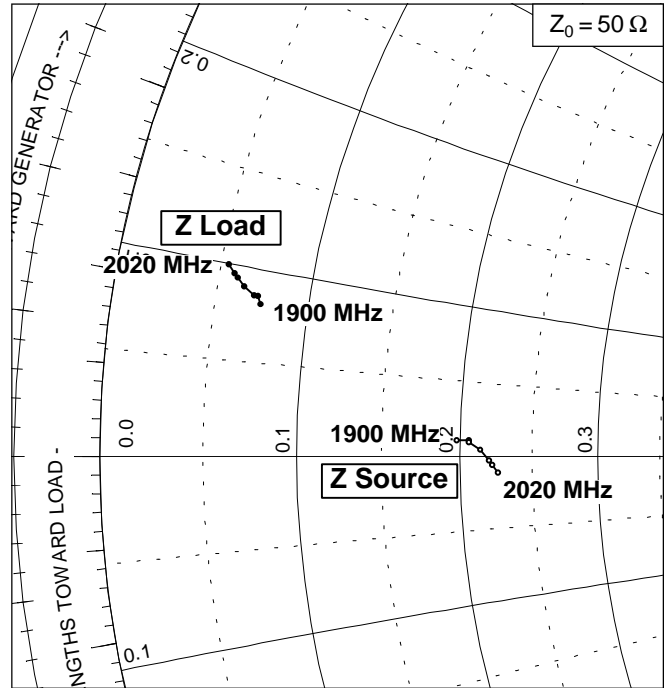

Reference Circuit

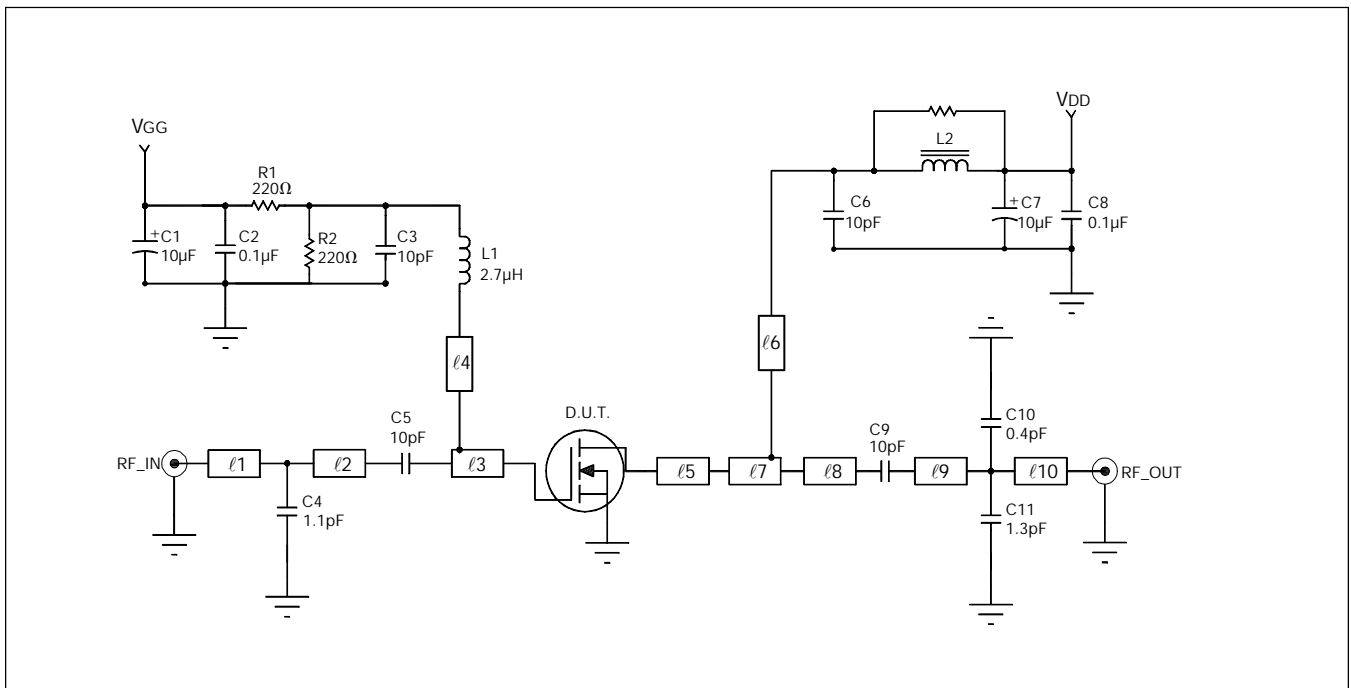

Reference Circuit Schematic for 1990 MHz

Reference Circuit (cont.)

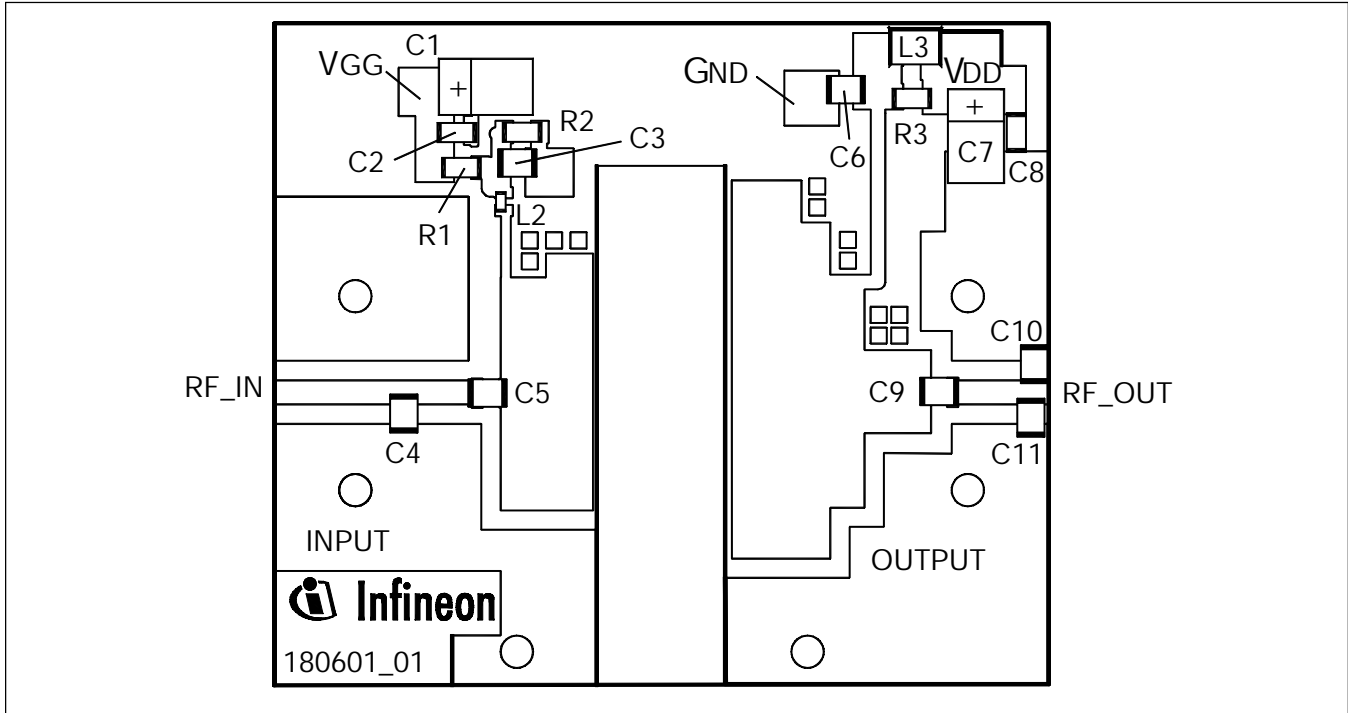

Reference circuit¹ (not to scale)

Circuit Assembly Information

DUT	PTF180601	LDMOS Transistor	
PCB	1.27 mm [0.050"] thick, $\epsilon_r = 6.0$	TMM6	2 oz. copper, both sides

Microstrip	Electrical Characteristics at 1990 MHz	Dimensions: L x W (mm.)	Dimensions: L x W (in.)
l_1	$0.140 \lambda, 50 \Omega$	10.16 x 1.88	0.400 x 0.074
l_2	$0.068 \lambda, 50 \Omega$	4.95 x 1.88	0.195 x 0.074
l_3	$0.112 \lambda, 9.24 \Omega$	7.14 x 18.31	0.281 x 0.721
l_4	$0.064 \lambda, 78 \Omega$	4.83 x 0.76	0.190 x 0.030
l_5	$0.127 \lambda, 6.64 \Omega$	8.13 x 26.42	0.320 x 1.040
l_6	$0.206 \lambda, 65 \Omega$	15.24 x 1.14	0.600 x 0.045
l_7	$0.035 \lambda, 9 \Omega$	2.54 x 18.16	0.100 x 0.715
l_8	$0.077 \lambda, 21.87 \Omega$	5.26 x 6.53	0.207 x 0.257
l_9	$0.075 \lambda, 50 \Omega$	5.46 x 1.88	0.215 x 0.074
l_{10}	$0.023 \lambda, 50 \Omega$	1.65 x 1.88	0.065 x 0.074

¹ Gerber files for this circuit are available on request.

Reference Circuit (cont.)

Component	Description	Manufacturer	P/N or Comment
C1, C7	Capacitor, 10 μ F, 35 V, SMD	Digi-Key	PCS6106TR-ND Tantalum TE Series
C2, C8	Capacitor, 0.1 μ F, 50 V	Digi-Key	PCC103BCT-ND
C3, C5, C6, C9	Capacitor, 10 pF	ATC	100B 100
C4	Capacitor, 1.1 pF	ATC	100B 1R1
C10	Capacitor, 0.4 pF	ATC	100B 0R4
C11	Capacitor, 1.3 pF	ATC	100B 1R3
L1	Chip Inductor, 2.7 μ H	Digi-Key	PCD1287CT-ND
L2	Ferrite, 6 mm	Philips	53/3/4.6-452
R1, R2	Resistor, 220 Ω	Digi-Key	P220ECT
R3	Resistor, 1.0 Ω	Digi-Key	1.0 PCT

Package Outline Specifications

Type	Package Outline	Package Description	Marking
PTF180601C	21248	Earless ceramic	PTF180601C
PTF180601E	30248	Thermally enhanced, flange mount	PTF180601E

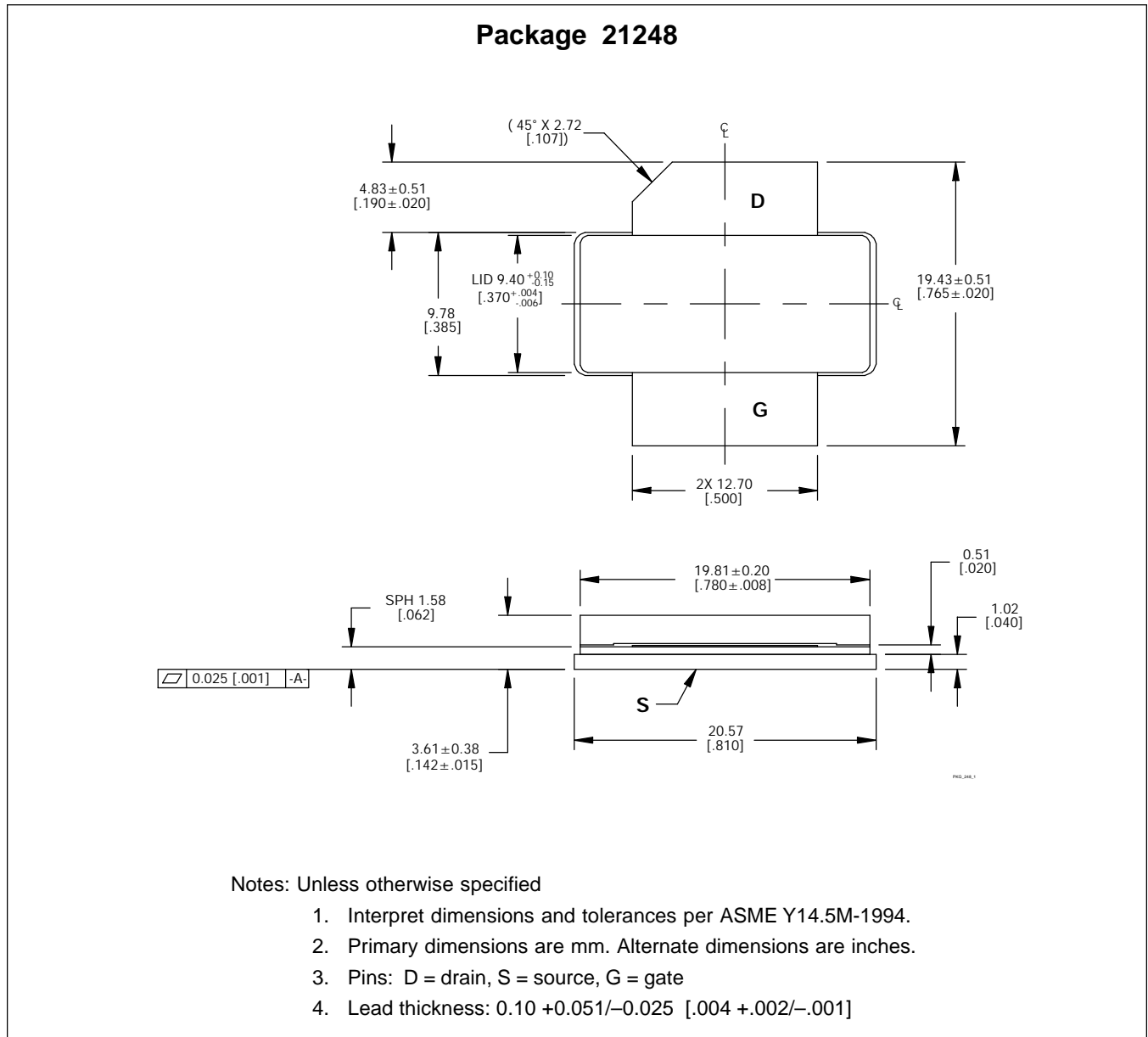

Find the latest and most complete information about products and packaging at the Infineon Internet page <http://www.infineon.com/products>

Package Outline Specifications (cont.)

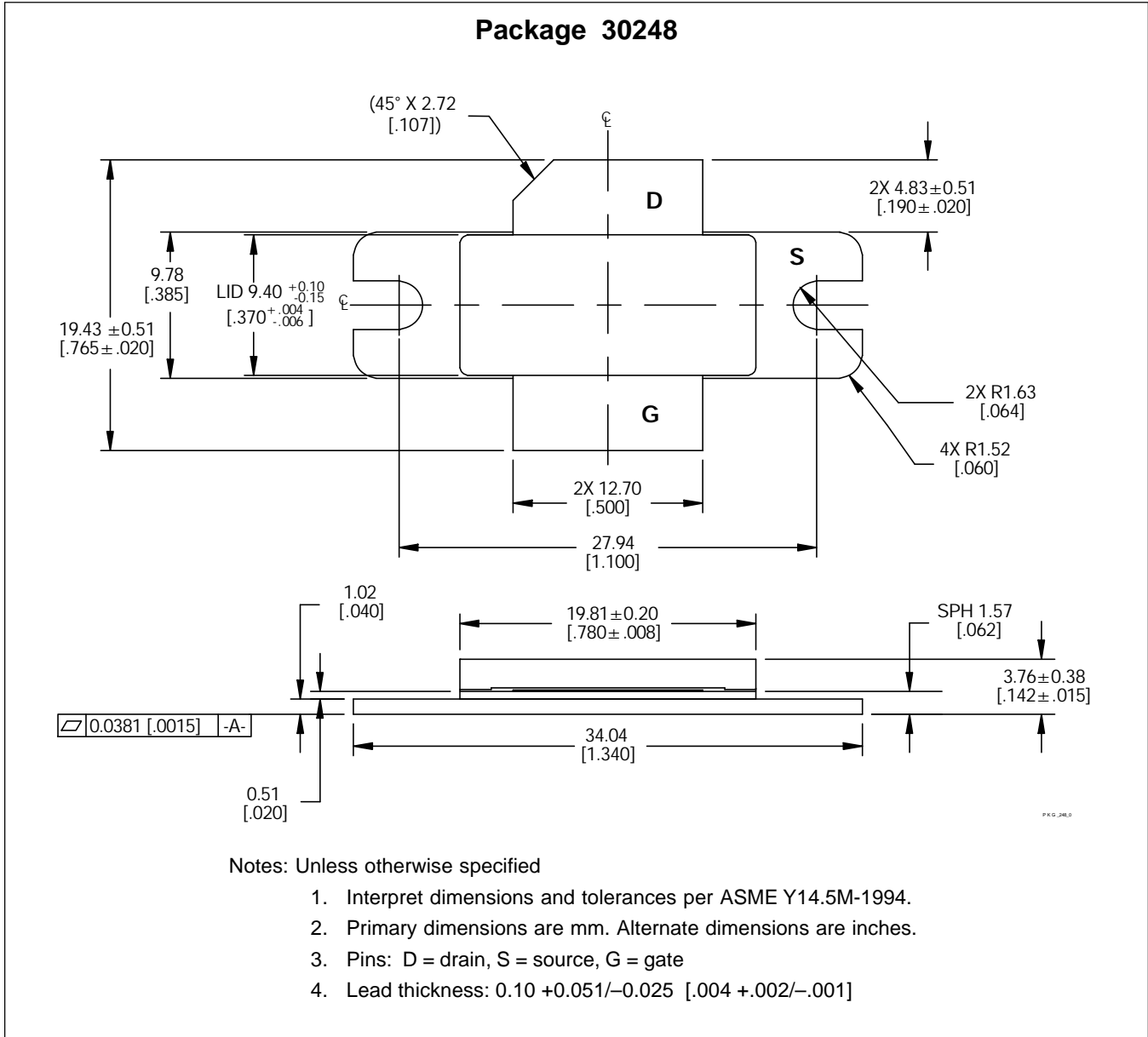

Find the latest and most complete information about products and packaging at the Infineon Internet page <http://www.infineon.com/products>

PTF180601

Revision History: 2004-05-03

Previous Version: 2003-12-22, Data Sheet

Page	Subjects (major changes since last revision)
	PTF180601E added.

We Listen to Your Comments

Any information within this document that you feel is wrong, unclear or missing at all?
Your feedback will help us to continuously improve the quality of this document.

Please send your proposal (including a reference to this document) to:

highpowerRF@infineon.com

To request other information, contact us at:
+1 877 465 3667 (1-877-GOLDMOS) USA
or +1 408 776 0600 International

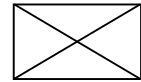

GOLDMOS® is a registered trademark of Infineon Technologies AG.

Edition 2004-05-03

**Published by Infineon Technologies AG,
St.-Martin-Strasse 53,
81669 München, Germany**

**© Infineon Technologies AG 2003.
All Rights Reserved.**

Attention please!

The information herein is given to describe certain components and shall not be considered as a guarantee of characteristics.

Terms of delivery and rights to technical change reserved.

We hereby disclaim any and all warranties, including but not limited to warranties of non-infringement, regarding circuits, descriptions and charts stated herein.

Information

For further information on technology, delivery terms and conditions and prices please contact your nearest Infineon Technologies Office (www.infineon.com/rfpower).

Warnings

Due to technical requirements components may contain dangerous substances. For information on the types in question please contact your nearest Infineon Technologies Office.

Infineon Technologies Components may only be used in life-support devices or systems with the express written approval of Infineon Technologies, if a failure of such components can reasonably be expected to cause the failure of that life-support device or system, or to affect the safety or effectiveness of that device or system. Life support devices or systems are intended to be implanted in the human body, or to support and/or maintain and sustain and/or protect human life. If they fail, it is reasonable to assume that the health of the user or other persons may be endangered.