



Integrated Device Technology, Inc.

24-BIT BUS EXCHANGE SWITCH

IDT74FST163212 ADVANCE INFORMATION

FEATURES:

- Bus switches provide zero delay paths
- Extended commercial range of -40°C to $+85^{\circ}\text{C}$
- Low switch on-resistance:
FST163xxx – 4Ω
- TTL-compatible input and output levels
- ESD > 2000V per MIL-STD-883, Method 3015;
> 200V using machine model (C = 200pF, R = 0)
- Available in SSOP, TSSOP and TVSOP

DESCRIPTION:

The FST163212 belongs to IDT's family of Bus switches. Bus switch devices perform the function of connecting or isolating two ports without providing any inherent current sink

or source capability. Thus they generate little or no noise of their own while providing a low resistance path for an external driver. These devices connect input and output ports through an n-channel FET. When the gate-to-source junction of this FET is adequately forward-biased the device conducts and the resistance between input and output ports is small. Without adequate bias on the gate-to-source junction of the FET, the FET is turned off, therefore with no VCC applied, the device has hot insertion capability.

The low on-resistance and simplicity of the connection between input and output ports reduces the delay in this path to close to zero.

The FST163212 provides four 12-bit TTL-compatible ports that support 2 way bus exchange. The S0-2 pins control the bus exchange and switch enable functions.

FUNCTIONAL BLOCK DIAGRAM

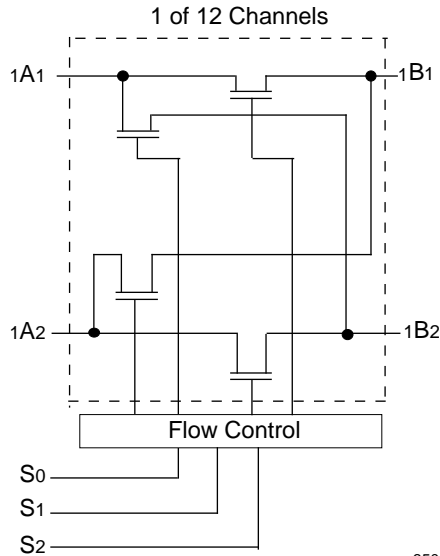

3508 drw 01

PIN DESCRIPTION

Pin Names	I/O	Description
A1, A2 B1, B2	I/O	Buses A1, A2, B1, B2
S0-2	I	Control Pins for Mux and Switch Enable Functions

3508 tbl 01

The IDT logo is a registered trademark of Integrated Device Technology, Inc.

COMMERCIAL TEMPERATURE RANGE

SEPTEMBER 1996

©1996 Integrated Device Technology, Inc.

DSC-3508/-

PIN CONFIGURATION

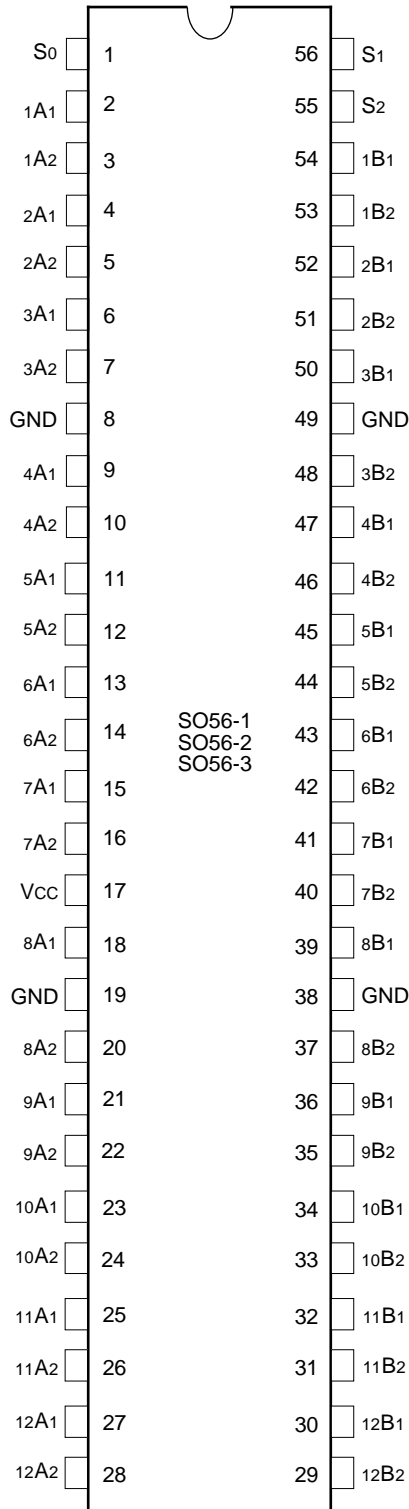

**SSOP/
TSSOP/TVSOP
TOP VIEW**

3508 drw 02

ABSOLUTE MAXIMUM RATINGS⁽¹⁾

Symbol	Description	Max.	Unit
VTERM ⁽²⁾	Terminal Voltage with Respect to GND	-0.5 to +7.0	V
TSTG	Storage Temperature	-65 to +150	°C
IOUT	Maximum Continuous Channel Current	128	mA

3508 tbl 02

NOTES:

- Stresses greater than those listed under ABSOLUTE MAXIMUM RATINGS may cause permanent damage to the device. This is a stress rating only and functional operation of the device at these or any other conditions above those indicated in the operational sections of this specification is not implied. Exposure to absolute maximum rating conditions for extended periods may affect reliability.
- Vcc, Control and Switch terminals.

CAPACITANCE⁽¹⁾

Symbol	Parameter	Conditions ⁽²⁾	Typ.	Unit
CIN	Control Input Capacitance		4	pF
Ci/O	Switch Input/Output Capacitance	Switch Off		pF

3508 tbl 03

NOTES:

- Capacitance is characterized but not tested
- TA = 25°C, f = 1MHz, VIN = 0V, VOUT = 0V

FUNCTION TABLE

S2	S1	S0	A1	A2	Function
L	L	L	Z	Z	Disconnect
L	L	H	B1	Z	A1 to B1
L	H	L	B2	Z	A1 to B2
L	H	H	Z	B1	A2 to B1
H	L	L	Z	B2	A2 to B2
H	L	H	Z	Z	Disconnect
H	H	L	B1	B2	A1 to B1, A2 to B2
H	H	H	B2	B1	A1 to B2, A2 to B1

3508 tbl 04

DC ELECTRICAL CHARACTERISTICS OVER OPERATING RANGE

Following Conditions Apply Unless Otherwise Specified:

Commercial: $T_A = -40^{\circ}\text{C}$ to $+85^{\circ}\text{C}$, $V_{CC} = 5.0\text{V} \pm 10\%$

Symbol	Parameter	Test Conditions ⁽¹⁾	Min.	Typ. ⁽²⁾	Max.	Unit	
V_{IH}	Input HIGH Voltage	Guaranteed Logic HIGH for Control Inputs	2.0	—	—	V	
V_{IL}	Input LOW Voltage	Guaranteed Logic LOW for Control Inputs	—	—	0.8	V	
I_{IH}	Input HIGH Current	$V_{CC} = \text{Max.}$	$V_I = V_{CC}$	—	—	± 1	μA
I_{IL}	Input LOW Current		$V_I = \text{GND}$	—	—	± 1	
I_{OZH}	High Impedance Output Current (3-State Output pins)	$V_{CC} = \text{Max.}$	$V_O = V_{CC}$	—	—	± 1	μA
I_{OZL}			$V_O = \text{GND}$	—	—	± 1	
I_{OS}	Short Circuit Current	$V_{CC} = \text{Max.}, V_O = \text{GND}^{(3)}$	—	300	—	mA	
V_{IK}	Clamp Diode Voltage	$V_{CC} = \text{Min.}, I_{IN} = -18\text{mA}$	—	-0.7	-1.2	V	
R_{ON}	Switch On Resistance ⁽⁴⁾	$V_{CC} = \text{Min.}, V_{IN} = 0.0\text{V}$ $I_{ON} = 64\text{mA}$	—	4	7	Ω	
		$V_{CC} = \text{Min.}, V_{IN} = 0.0\text{V}$ $I_{ON} = 30\text{mA}$	—	4	7	Ω	
		$V_{CC} = \text{Min.}, V_{IN} = 2.4\text{V}$ $I_{ON} = 15\text{mA}$	—	10	15	Ω	
I_{OFF}	Input/Output Power Off Leakage	$V_{CC} = 0\text{V}, V_{IN}$ or $V_O \leq 4.5\text{V}$	—	—	± 1	μA	
I_{CC}	Quiescent Power Supply Current	$V_{CC} = \text{Max.}, V_{IN} = \text{GND}$ or V_{CC}	—	0.1	3	μA	

NOTES:

1. For conditions shown as Max. or Min., use appropriate value specified under Electrical Characteristics for the applicable device type.
2. Typical values are at $V_{CC} = 5.0\text{V}$, $+25^{\circ}\text{C}$ ambient.
3. Not more than one output should be tested at one time. Duration of the test should not exceed one second.
4. Measured by voltage drop between ports at indicated current through the switch.

3508 tbl 05

POWER SUPPLY CHARACTERISTICS

Symbol	Parameter	Test Conditions ⁽¹⁾		Min.	Typ. ⁽²⁾	Max.	Unit
ΔI_{CC}	Quiescent Power Supply Current TTL Inputs HIGH	V _{CC} = Max. V _{IN} = 3.4V ⁽³⁾		—	0.5	1.5	mA
I _{CCD}	Dynamic Power Supply Current ⁽⁴⁾	V _{CC} = Max. Outputs Open Enable Pin Toggling 50% Duty Cycle	V _{IN} = V _{CC} V _{IN} = GND	—	30	40	μA/ MHz/ Switch
I _C	Total Power Supply Current ⁽⁶⁾	V _{CC} = Max. Outputs Open Enable Pins Toggling (24 Switches Toggling) f _i = 10MHz 50% Duty Cycle	V _{IN} = V _{CC} V _{IN} = GND V _{IN} = 3.4 V _{IN} = GND	—	7.2 7.7	9.6 11.1	mA

3508 tbl 06

NOTES:

- For conditions shown as Max. or Min., use appropriate value specified under Electrical Characteristics for the applicable device type.
- Typical values are at V_{CC} = 5.0V, +25°C ambient.
- Per TTL driven input (V_{IN} = 3.4V). All other inputs at V_{CC} or GND.
- This parameter is not directly testable, but is derived for use in Total Power Supply Calculations.
- Values for these conditions are examples of the I_{CC} formula. These limits are guaranteed but not tested.
- I_C = I_{QUIESCENT} + I_{INPUTS} + I_{DYNAMIC}
I_C = I_{CC} + $\Delta I_{CC} \cdot D_{HT} + I_{CCD} \cdot (f_i N)$
I_{CC} = Quiescent Current
 ΔI_{CC} = Power Supply Current for a TTL High Input (V_{IN} = 3.4V)
D_H = Duty Cycle for TTL Inputs High
N_T = Number of TTL Inputs at D_H
I_{CCD} = Dynamic Current Caused by an Input Transition Pair (HLH or LHL)
f_i = Input Frequency
N = Number of Switches Toggling at f_i
All currents are in milliamps and all frequencies are in megahertz.

SWITCHING CHARACTERISTICS OVER OPERATING RANGE

Following Conditions Apply Unless Otherwise Specified:

Commercial: T_A = -40°C to +85°C, V_{CC} = 5.0V ±10%

Symbol	Description	Condition ⁽¹⁾	Min. ⁽²⁾	Typ.	Max.	Unit
t _{PLH}	Data Propagation Delay A to B, B to A ^(3,4)	C _L = 50pF R _L = 500Ω	—	—	0.25	ns
t _{BX}	Switch Multiplex Delay S to A, B		1.5	—	6.5	ns
t _{PZH}	Switch Turn on Delay S to A, B		1.5	—	6.5	ns
t _{PHZ}	Switch Turn off Delay S to A, B ⁽³⁾		1.5	—	7	ns
Q _{CI}	Charge Injection, Typical ^(5,7)		—	1.5	—	pC
Q _{DCI}	Charge Injection, Typical ^(6,7)		—	0.5	—	

3508 tbl 07

NOTES:

- See test circuit and waveforms.
- Minimum limits guaranteed but not tested.
- This parameter is guaranteed by design but not tested.
- The bus switch contributes no propagation delay other than the RC delay of the on resistance of the switch and the load capacitance. The time constant for the switch alone is of the order of 2.5ns for 50pF load. Since this time is constant and much smaller than the rise/fall times of typical driving signals, it adds very little propagation delay to the system. Propagation delay on the bus switch when used in a system is determined by the driving circuit on the driving side of the switch and its interaction with the load on the driven side.
- Measured at switch turn off, load = 50 pF in parallel with 10 MΩ scope probe, V_{IN} = 0.0 volts.
- Measured at switch turn off through bus multiplexer, (e.g.- A₁ to B₁ => A₁ to B₂), load = 50 pF in parallel with 10 MΩ scope probe, V_{IN} at A = 0.0 volts. Charge injection is reduced because the injection from the turn off of the A₁ to B₁ switch is compensated by the turn on of the A₁ to B₂ switch.
- Characterized parameter. Not 100% tested.

TEST CIRCUITS AND WAVEFORMS

TEST CIRCUITS FOR ALL OUTPUTS

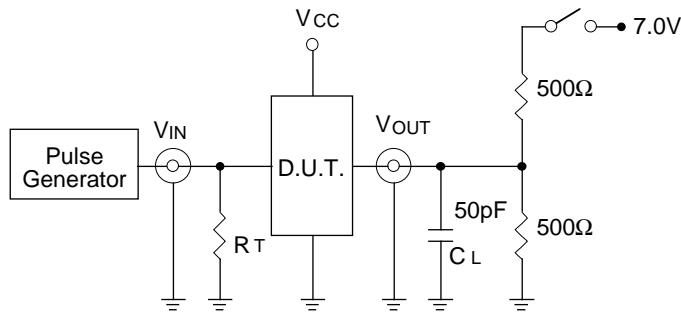

3508 Ink 03

SWITCH POSITION

Test	Switch
Open Drain Disable Low Enable Low	Closed
All Other Tests	Open

3508 Ink 08

DEFINITIONS:

CL = Load capacitance: includes jig and probe capacitance.
RT = Termination resistance: should be equal to ZOUT of the Pulse Generator.

SET-UP, HOLD AND RELEASE TIMES

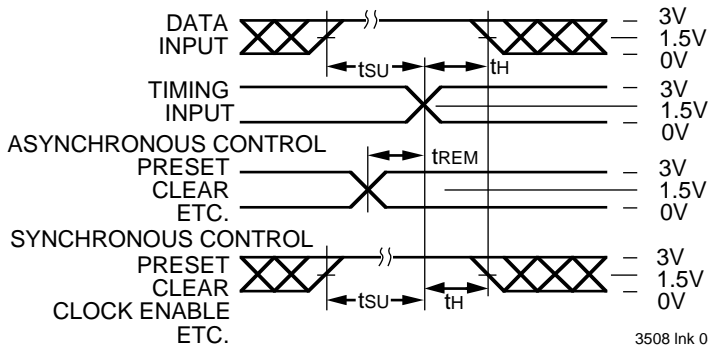

3508 Ink 04

PULSE WIDTH

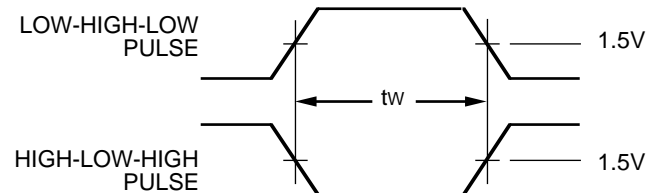

3508 Ink 05

PROPAGATION DELAY

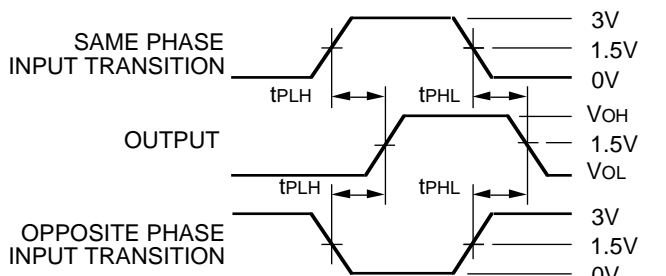

3508 Ink 06

ENABLE AND DISABLE TIMES

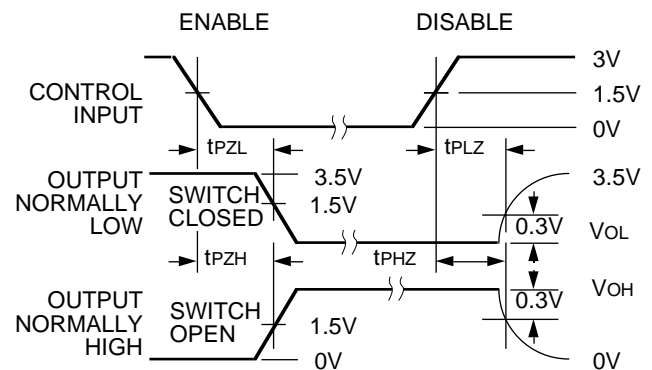

3508 Ink 07

NOTES:

1. Diagram shown for input Control Enable-LOW and input Control Disable-HIGH
2. Pulse Generator for All Pulses: Rate \leq 1.0MHz; $t_f \leq$ 2.5ns; $t_r \leq$ 2.5ns

ORDERING INFORMATION

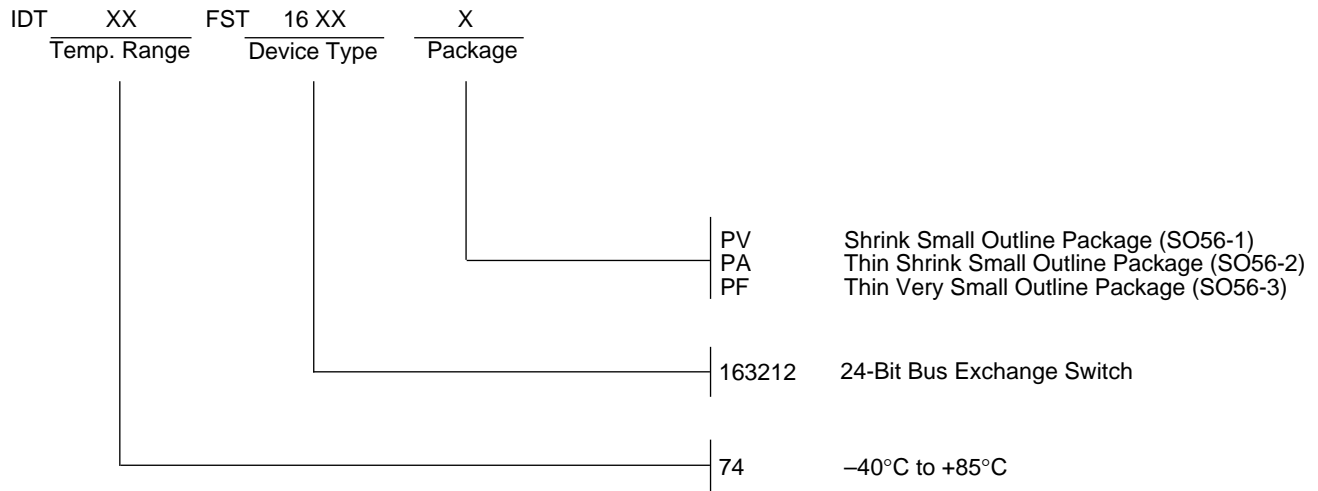

3508 drw 08