



Integrated Device Technology, Inc.

3.3V CMOS 10-BIT BUFFERS

IDT54/74FCT3827A/B

FEATURES:

- 0.5 MICRON CMOS Technology
- ESD > 2000V per MIL-STD-883, Method 3015; > 200V using machine model (C = 200pF, R = 0)
- 25 mil Center SSOP Packages
- Extended commercial range of -40°C to +85°C
- VCC = 3.3V ±0.3V, Normal Range or VCC = 2.7V to 3.6V, Extended Range
- CMOS power levels (0.4µW typ. static)
- Rail-to-Rail output swing for increased noise margin
- Military product compliant to MIL-STD-883, Class B

DESCRIPTION:

The FCT3827A/B 10-bit bus drivers are built using an advanced dual metal CMOS technology. These high speed, low power buffers are ideal for high-performance bus interface buffering for wide data/address paths or buses carrying parity. The 10-bit buffers have NAND-ed output enables for maximum control flexibility.

All of the FCT3827 high performance interface components are designed for high-capacitance load drive capability, while providing low-capacitance bus loading at both inputs and outputs.

FUNCTIONAL BLOCK DIAGRAM

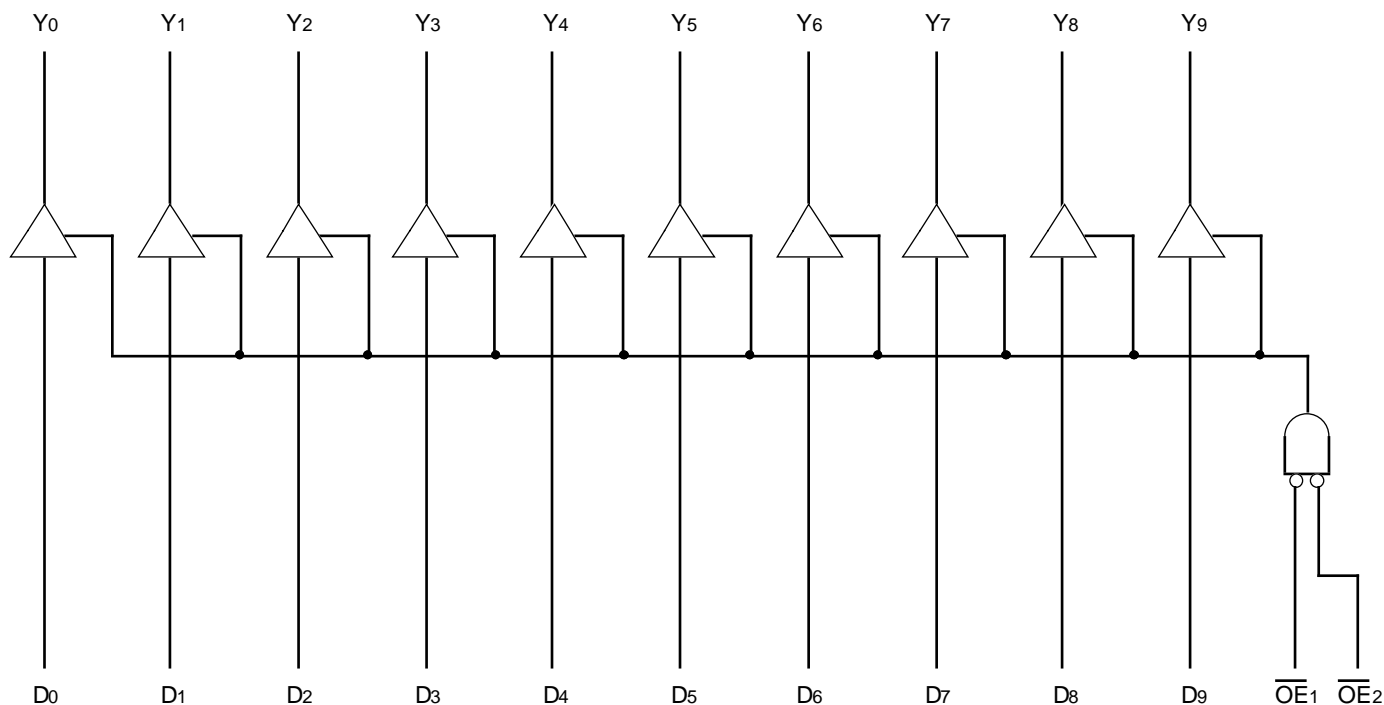

3092 drw 01

The IDT logo is a registered trademark of Integrated Device Technology, Inc.

MILITARY AND COMMERCIAL TEMPERATURE RANGES

AUGUST 1995

PIN CONFIGURATIONS

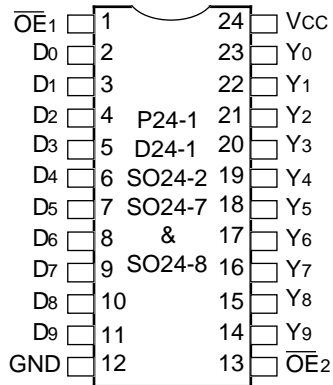

DIP/SOIC/SSOP/QSOP
TOP VIEW

3092 drw 02

PIN DESCRIPTION

Names	I/O	Description
\overline{OE}_i	I	When both are LOW the outputs are enabled. When either one or both are HIGH the outputs are High Z.
DI	I	10-bit data input.
Yi	O	10-bit data output.

3092 tbl 01

FUNCTION TABLE⁽¹⁾

Inputs			Output	Function
\overline{OE}_1	\overline{OE}_2	DI	Yi	
L	L	L	L	Transparent
L	L	H	H	
H	X	X	Z	Three-State
X	H	X	Z	

3092 tbl 02

NOTE:

- H = HIGH Voltage Level
X = Don't Care
L = LOW Voltage Level
Z = High Impedance

ABSOLUTE MAXIMUM RATINGS⁽¹⁾

Symbol	Rating	Commercial	Military	Unit
VTERM ⁽²⁾	Terminal Voltage with Respect to GND	-0.5 to +4.6	-0.5 to +4.6	V
VTERM ⁽³⁾	Terminal Voltage with Respect to GND	-0.5 to +7.0	-0.5 to +7.0	V
VTERM ⁽⁴⁾	Terminal Voltage with Respect to GND	-0.5 to Vcc + 0.5	-0.5 to Vcc + 0.5	V
TA	Operating Temperature	-40 to +85	-55 to +125	°C
TBIAS	Temperature Under Bias	-55 to +125	-65 to +135	°C
TSTG	Storage Temperature	-55 to +125	-65 to +150	°C
PT	Power Dissipation	1.0	1.0	W
IOUT	DC Output Current	-60 to +60	-60 to +60	mA

3092 lmk 03

NOTES:

- Stresses greater than those listed under ABSOLUTE MAXIMUM RATINGS may cause permanent damage to the device. This is a stress rating only and functional operation of the device at these or any other conditions above those indicated in the operational sections of this specification is not implied. Exposure to absolute maximum rating conditions for extended periods may affect reliability.
- Vcc terminals.
- Input terminals.
- Output and I/O terminals.

CAPACITANCE (TA = +25°C, f = 1.0MHz)

Symbol	Parameter ⁽¹⁾	Conditions	Typ.	Max.	Unit
CIN	Input Capacitance	VIN = 0V	3.5	6.0	pF
COU	Output Capacitance	VOU = 0V	4.0	8.0	pF

NOTE:

- This parameter is measured at characterization but not tested.

3092 lmk 04

DC ELECTRICAL CHARACTERISTICS OVER OPERATING RANGE

Following Conditions Apply Unless Otherwise Specified:

Commercial: $T_A = -40^\circ\text{C}$ to $+85^\circ\text{C}$, $V_{CC} = 2.7\text{V}$ to 3.6V ; Military: $T_A = -55^\circ\text{C}$ to $+125^\circ\text{C}$, $V_{CC} = 2.7\text{V}$ to 3.6V

Symbol	Parameter	Test Conditions ⁽¹⁾	Min.	Typ. ⁽²⁾	Max.	Unit	
V_{IH}	Input HIGH Level (Input pins)	Guaranteed Logic HIGH Level	2.0	—	5.5	V	
	Input HIGH Level (I/O pins)		2.0	—	$V_{CC}+0.5$		
V_{IL}	Input LOW Level (Input and I/O pins)	Guaranteed Logic LOW Level	-0.5	—	0.8	V	
I_{IH}	Input HIGH Current (Input pins) ⁽⁶⁾	$V_{CC} = \text{Max.}$	$V_I = 5.5\text{V}$	—	—	± 1	μA
	Input HIGH Current (I/O pins) ⁽⁶⁾		$V_I = V_{CC}$	—	—	± 1	
I_{IL}	Input LOW Current (Input pins) ⁽⁶⁾		$V_I = \text{GND}$	—	—	± 1	
	Input LOW Current (I/O pins) ⁽⁶⁾		$V_I = \text{GND}$	—	—	± 1	
I_{OZH}	High Impedance Output Current (3-State Output pins) ⁽⁶⁾	$V_{CC} = \text{Max.}$	$V_O = V_{CC}$	—	—	± 1	μA
I_{OZL}			$V_O = \text{GND}$	—	—	± 1	
V_{IK}	Clamp Diode Voltage	$V_{CC} = \text{Min.}, I_{IN} = -18\text{mA}$	—	-0.7	-1.2	V	
I_{ODH}	Output HIGH Current	$V_{CC} = 3.3\text{V}, V_{IN} = V_{IH}$ or $V_{IL}, V_O = 1.5\text{V}^{(3)}$	-36	-60	-110	mA	
I_{ODL}	Output LOW Current	$V_{CC} = 3.3\text{V}, V_{IN} = V_{IH}$ or $V_{IL}, V_O = 1.5\text{V}^{(3)}$	50	90	200	mA	
V_{OH}	Output HIGH Voltage	$V_{CC} = \text{Min.}$ $V_{IN} = V_{IH}$ or V_{IL}	$I_{OH} = -0.1\text{mA}$	$V_{CC}-0.2$	—	—	V
			$I_{OH} = -3\text{mA}$	2.4	3.0	—	
		$V_{CC} = 3.0\text{V}$ $V_{IN} = V_{IH}$ or V_{IL}	$I_{OH} = -6\text{mA MIL.}$ $I_{OH} = -8\text{mA COM'L.}$	2.4 ⁽⁵⁾	3.0	—	
V_{OL}	Output LOW Voltage	$V_{CC} = \text{Min.}$ $V_{IN} = V_{IH}$ or V_{IL}	$I_{OL} = 0.1\text{mA}$	—	—	0.2	V
			$I_{OL} = 16\text{mA}$	—	0.2	0.4	
			$I_{OL} = 24\text{mA}$	—	0.3	0.55	
		$V_{CC} = 3.0\text{V}$ $V_{IN} = V_{IH}$ or V_{IL}	$I_{OL} = 24\text{mA}$	—	0.3	0.50	
I_{OS}	Short Circuit Current ⁽⁴⁾	$V_{CC} = \text{Max.}, V_O = \text{GND}^{(3)}$	-60	-135	-240	mA	
V_H	Input Hysteresis	—	—	150	—	mV	
I_{CCL}	Quiescent Power Supply Current	$V_{CC} = \text{Max.},$ $V_{IN} = \text{GND}$ or V_{CC}	COM'L.	—	0.1	10	μA
I_{CCH}			MIL.	—	0.1	100	
I_{CCZ}			MIL.	—	0.1	100	

3092 Ink 05

NOTES:

- For conditions shown as Max. or Min., use appropriate value specified under Electrical Characteristics for the applicable device type.
- Typical values are at $V_{CC} = 3.3\text{V}, +25^\circ\text{C}$ ambient.
- Not more than one output should be tested at one time. Duration of the test should not exceed one second.
- This parameter is guaranteed but not tested.
- $V_{OH} = V_{CC} - 0.6\text{V}$ at rated current.
- The test limits for this parameter is $\pm 5\mu\text{A}$ at $T_A = -55^\circ\text{C}$.

POWER SUPPLY CHARACTERISTICS

Symbol	Parameter	Test Conditions ⁽¹⁾		Min.	Typ. ⁽²⁾	Max.	Unit
ΔI_{CC}	Quiescent Power Supply Current	$V_{CC} = \text{Max.}$	$V_{IN} = V_{CC} - 0.6V^{(3)}$	—	2.0	30	μA
I_{CCD}	Dynamic Power Supply Current ⁽⁴⁾	$V_{CC} = \text{Max.}$ Outputs Open $\overline{OE}_1 = \overline{OE}_2 = \text{GND}$ One Input Toggling 50% Duty Cycle	$V_{IN} = V_{CC}$ $V_{IN} = \text{GND}$	—	60	85	$\mu A / \text{MHz}$
I_C	Total Power Supply Current ⁽⁶⁾	$V_{CC} = \text{Max.}$ Outputs Open $f_i = 10\text{MHz}$ 50% Duty Cycle $\overline{OE}_1 = \overline{OE}_2 = \text{GND}$ One Bit Toggling	$V_{IN} = V_{CC}$ $V_{IN} = \text{GND}$	—	0.6	0.9	mA
			$V_{IN} = V_{CC} - 0.6V$ $V_{IN} = \text{GND}$	—	0.6	0.9	
		$V_{CC} = \text{Max.}$ Outputs Open $f_i = 2.5\text{MHz}$ 50% Duty Cycle $\overline{OE}_1 = \overline{OE}_2 = \text{GND}$ Ten Bits Toggling	$V_{IN} = V_{CC}$ $V_{IN} = \text{GND}$	—	1.5	2.1 ⁽⁵⁾	
			$V_{IN} = V_{CC} - 0.6V$ $V_{IN} = \text{GND}$	—	1.5	2.3 ⁽⁵⁾	

NOTES:

3092 tbl 06

- For conditions shown as max. or min., use appropriate value specified under Electrical Characteristics for the applicable device type.
- Typical values are at $V_{CC} = 3.3V$, $+25^\circ C$ ambient.
- Per TTL driven input; all other inputs at V_{CC} or GND .
- This parameter is not directly testable, but is derived for use in Total Power Supply Calculations.
- Values for these conditions are examples of the I_{CC} formula. These limits are guaranteed but not tested.
- $I_C = I_{QUIESCENT} + I_{INPUTS} + I_{DYNAMIC}$
 $I_C = I_{CC} + \Delta I_{CC} D_H N_T + I_{CCD} (f_C P_{NCP} / 2 + f_i N_i)$
 $I_{CC} = \text{Quiescent Current (} I_{CCL}, I_{CCH} \text{ and } I_{CCZ})$
 $\Delta I_{CC} = \text{Power Supply Current for a TTL High Input}$
 $D_H = \text{Duty Cycle for TTL Inputs High}$
 $N_T = \text{Number of TTL Inputs at } D_H$
 $I_{CCD} = \text{Dynamic Current Caused by an Input Transition Pair (HLH or LHL)}$
 $f_C = \text{Clock Frequency for Register Devices (Zero for Non-Register Devices)}$
 $P_{NCP} = \text{Number of Clock Inputs at } f_C$
 $f_i = \text{Input Frequency}$
 $N_i = \text{Number of Inputs at } f_i$

SWITCHING CHARACTERISTICS OVER OPERATING RANGE⁽³⁾

Symbol	Parameter	Condition ⁽¹⁾	FCT3827A				FCT3827B				Unit
			Com'l.		Mil.		Com'l.		Mil.		
			Min. ⁽²⁾	Max.	Min. ⁽²⁾	Max.	Min. ⁽²⁾	Max.	Min. ⁽²⁾	Max.	
tPLH tPHL	Propagation Delay DI to Yi	CL = 50pF RL = 500Ω	1.5	8.0	1.5	9.0	1.5	5.0	1.5	6.5	ns
		CL = 300pF ⁽³⁾ RL = 500Ω	1.5	15.0	1.5	17.0	1.5	13.0	1.5	14.0	
tPZH tPZL	Output Enable Time $\overline{OE}i$ to Yi	CL = 50pF RL = 500Ω	1.5	12.0	1.5	13.0	1.5	8.0	1.5	9.0	ns
		CL = 300pF ⁽³⁾ RL = 500Ω	1.5	23.0	1.5	25.0	1.5	15.0	1.5	16.0	
tPHZ tPLZ	Output Disable Time $\overline{OE}i$ to Yi	CL = 5pF ⁽³⁾ RL = 500Ω	1.5	9.0	1.5	9.0	1.5	6.0	1.5	7.0	ns
		CL = 50pF RL = 500Ω	1.5	10.0	1.5	10.0	1.5	7.0	1.5	8.0	

NOTES:

3092 tbi 07

1. See test circuit and waveforms.
2. Minimum limits are guaranteed but not tested on Propagation Delays.
3. Propagation Delays and Enable/Disable times are with $V_{CC} = 3.3V \pm 0.3V$, Normal Range. For $V_{CC} = 2.7V$ to $3.6V$, Extended Range, all Propagation Delays and Enable/Disable times should be degraded by 20%.

TEST CIRCUITS AND WAVEFORMS

TEST CIRCUITS FOR ALL OUTPUTS

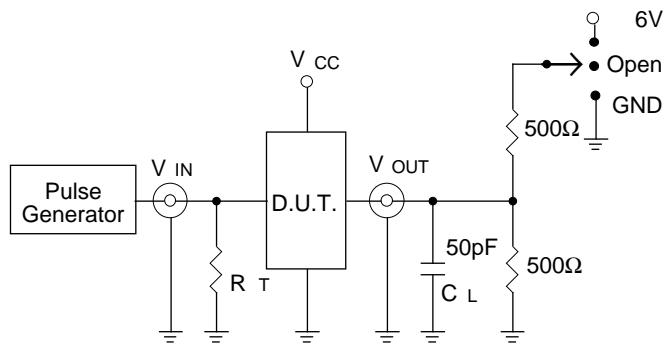

3092 drw 03

SWITCH POSITION

Test	Switch
Open Drain Disable Low Enable Low	6V
Disable High Enable High	GND
All Other tests	Open

DEFINITIONS:

C_L = Load capacitance: includes jig and probe capacitance.

R_T = Termination resistance: should be equal to Z_{OUT} of the Pulse Generator.

3092 Ink 08

SET-UP, HOLD AND RELEASE TIMES

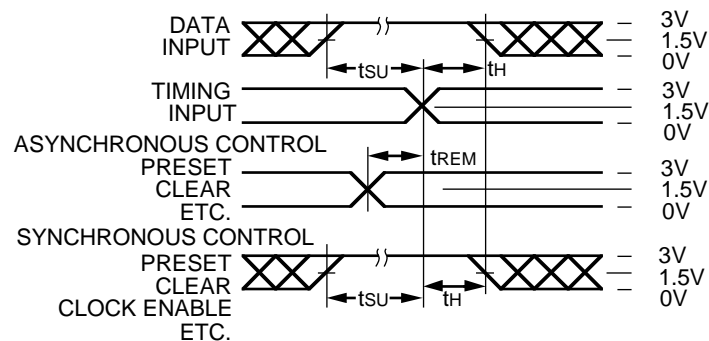

3092 drw 04

PULSE WIDTH

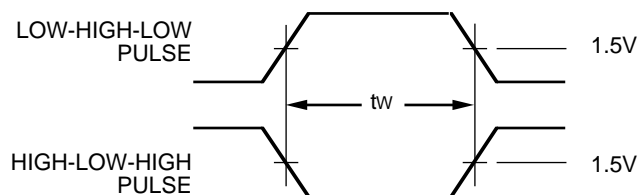

3092 drw 05

PROPAGATION DELAY

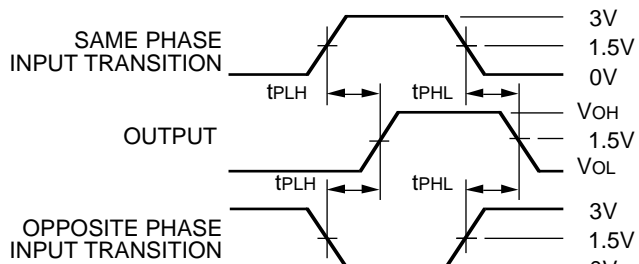

3092 drw 06

ENABLE AND DISABLE TIMES

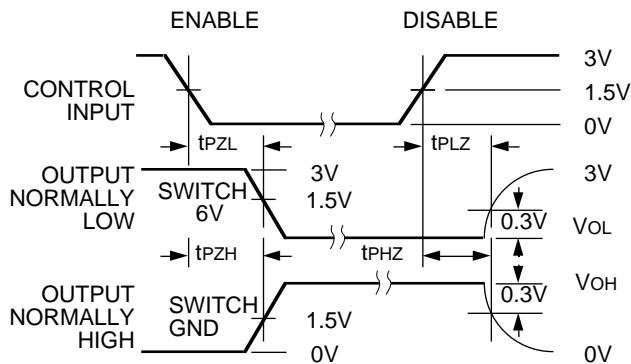

3092 drw 07

NOTES:

- Diagram shown for input Control Enable-LOW and input Control Disable-HIGH.
- Pulse Generator for All Pulses: Rate ≤ 1.0 MHz; $t_f \leq 2.5$ ns; $t_r \leq 2.5$ ns.
- If V_{CC} is below 3V, input voltage swings should be adjusted not to exceed V_{CC} .

ORDERING INFORMATION

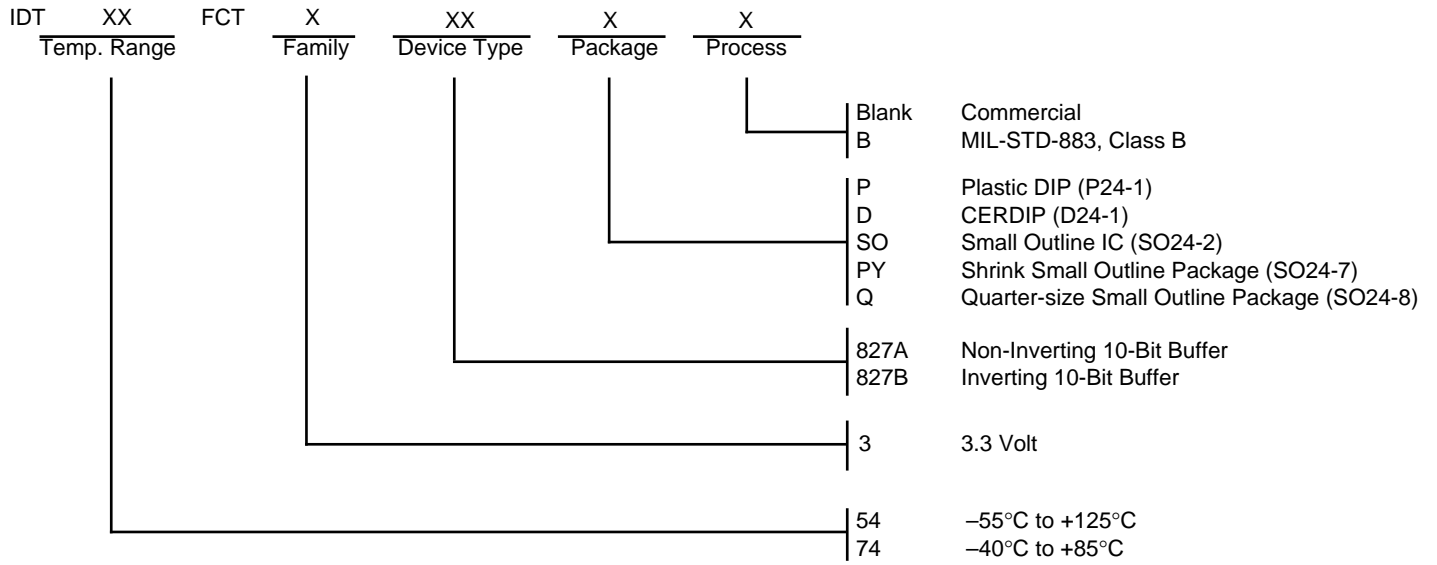

3092 drw 08