



FAST CMOS OCTAL BUS TRANSCEIVER (OPEN DRAIN)

IDT54/74FCT621T/AT

FEATURES:

- Std. and A speed grades
- Low input and output leakage $\leq 1\mu\text{A}$ (max.)
- Extended commercial range of -40°C to $+85^\circ\text{C}$
- CMOS power levels
- True TTL input and output compatibility
 - $V_{OH} = 3.3\text{V}$ (typ.)
 - $V_{OL} = 0.3\text{V}$ (typ.)
- Power off disable outputs permit "live insertion"
- Meets or exceeds JEDEC standard 18 specifications
- Product available in Radiation Tolerant and Radiation Enhanced versions
- Military product compliant to MIL-STD-883, Class B and DESC listed (dual marked)
- Available in DIP, SOIC, CERPACK and LCC packages

DESCRIPTION:

The IDT54/74FCT621T/AT is an octal transceiver with non-inverting Open-Drain bus compatible outputs in both send and receive directions. The B bus outputs are capable of sinking 64mA providing very good capacitive drive characteristics. These octal bus transceivers are designed for asynchronous two-way communication between data buses. The control function implementation allows for maximum flexibility in timing.

FUNCTIONAL BLOCK DIAGRAM

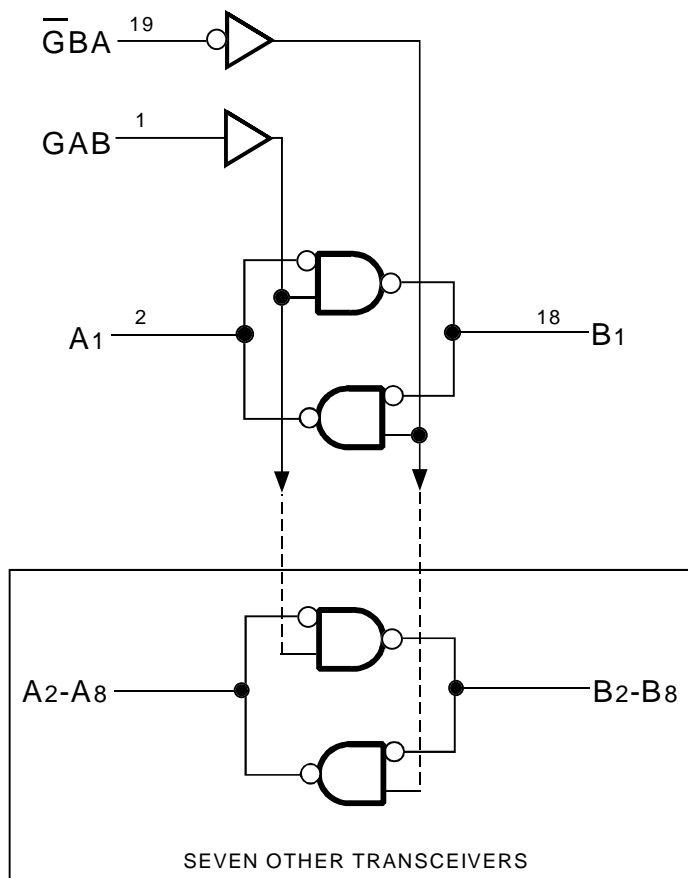

MILITARY AND COMMERCIAL TEMPERATURE RANGES

AUGUST 1999

PIN CONFIGURATION

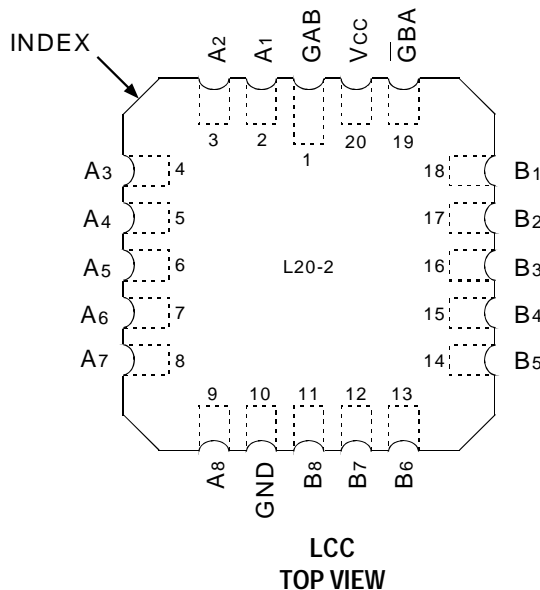
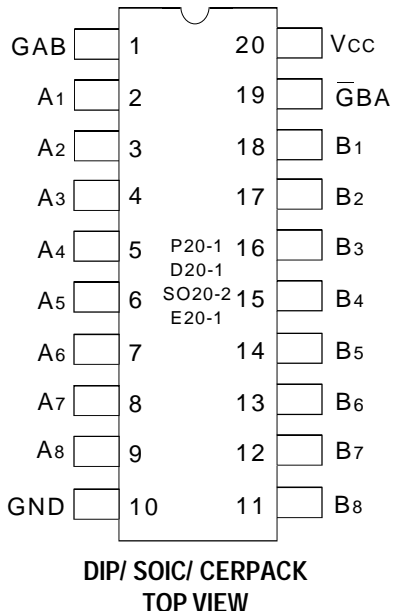

ABSOLUTE MAXIMUM RATINGS⁽¹⁾

Symbol	Rating	Max.	Unit
V _{TERM} ⁽²⁾	Terminal Voltage with Respect to GND	-0.5 to +7	V
V _{TERM} ⁽³⁾	Terminal Voltage with Respect to GND	-0.5 to V _{CC} +0.5	V
T _{STG}	Storage Temperature	-65 to +150	°C
I _{OUT}	DC Output Current	-65 to +120	mA

8T-link

NOTES:

- Stresses greater than those listed under ABSOLUTE MAXIMUM RATINGS may cause permanent damage to the device. This is a stress rating only and functional operation of the device at these or any other conditions above those indicated in the operational sections of this specification is not implied. Exposure to absolute maximum rating conditions for extended periods may affect reliability. No terminal voltage may exceed V_{CC} by +0.5V unless otherwise noted.
- Inputs and V_{CC} terminals only.
- Outputs and I/O terminals only.

CAPACITANCE (T_A = +25°C, f = 1.0MHz)

Symbol	Parameter ⁽¹⁾	Conditions	Typ.	Max.	Unit
C _{IN}	Input Capacitance	V _{IN} = 0V	6	10	pF
C _{OUT}	Output Capacitance	V _{OUT} = 0V	8	12	pF

8T-link

NOTE:

- This parameter is measured at characterization but not tested.

PIN DESCRIPTION

Pin Names	Description
$\overline{\text{GBA}}$, GAB	Enable Inputs
A1 – A8	A Inputs or Open-drain Outputs
B1 – B8	B Inputs or Open-drain Outputs

FUNCTION TABLE⁽¹⁾

Enable Inputs		Function
$\overline{\text{GBA}}$	GAB	
L	L	B data to A bus
H	H	A data to B bus
H	L	OFF
L	H	B data to A bus A data to B bus

NOTE:

- H = HIGH Voltage Level.
L = LOW Voltage Level.
OFF = HIGH if pull-up resistor is connected to Open-Drain output.

DC ELECTRICAL CHARACTERISTICS OVER OPERATING RANGE

Following conditions Apply Unless Otherwise Specified:

Commercial: $T_A = -40^{\circ}\text{C}$ to $+85^{\circ}\text{C}$, $V_{CC} = 5.0\text{V} \pm 5\%$; Military: $T_A = -55^{\circ}\text{C}$ to $+125^{\circ}\text{C}$, $V_{CC} = 5.0\text{V} \pm 10\%$

Symbol	Parameter	Test Conditions ⁽¹⁾		Min.	Typ. ⁽²⁾	Max.	Unit
V_{IH}	Input HIGH Level	Guaranteed Logic HIGH Level		2	—	—	V
V_{IL}	Input LOW Level	Guaranteed Logic LOW Level		—	—	0.8	V
I_{IH}	Input HIGH Current ⁽⁴⁾	$V_{CC} = \text{Max.}, V_I = 2.7\text{V}$		—	—	± 1	μA
I_{IL}	Input LOW Current ⁽⁴⁾	$V_{CC} = \text{Max.}, V_I = 0.5\text{V}$		—	—	± 1	μA
I_I	Input HIGH Current ⁽⁴⁾	$V_{CC} = \text{Max.}, V_I = V_{CC} (\text{Max.})$		—	—	± 1	μA
V_{IK}	Clamp Diode Voltage	$V_{CC} = \text{Min.}, I_{IN} = -18\text{mA}$		—	-0.7	-1.2	V
I_{OH}	Output HIGH Current	$V_{CC} = \text{Max.}$ $V_{IN} = V_{IH}$ or V_{IL}	$V_{OH} = V_{CC} (\text{Max.})$	—	—	20	μA
V_{OL}	Output LOW Voltage (B Bus)	$V_{CC} = \text{Min.}$ $V_{IN} = V_{IH}$ or V_{IL}	$I_{OL} = 48\text{mA MIL.}^{(3)}$ $I_{OL} = 64\text{mA COM'L.}$	—	0.3	0.55	V
V_{OL}	Output LOW Voltage (A Bus)	$V_{CC} = \text{Min.}$ $V_{IN} = V_{IH}$ or V_{IL}	$I_{OL} = 32\text{mA MIL.}^{(3)}$ $I_{OL} = 48\text{mA COM'L.}$	—	0.3	0.5	V
I_{OFF}	Input/Output Power Off Leakage ⁽⁴⁾	$V_{CC} = 0\text{V}, V_{IN}$ or $V_O = 4.5\text{V}$		—	—	± 1	μA
V_H	Input Hysteresis	—		—	200	—	mV
I_{CC}	Quiescent Power Supply Current	$V_{CC} = \text{max.}, V_{IN} = \text{GND}$ or V_{CC} —		0.01	1	mA	

NOTES:

- For conditions shown as Max. or Min., use appropriate value specified under Electrical Characteristics for the applicable device type.
- Typical values are at $V_{CC} = 5.0\text{V}$, $+25^{\circ}\text{C}$ ambient.
- These are maximum I_{OL} values per output, for 8 outputs turned on simultaneously. Total maximum I_{OL} (all outputs) is 512mA for commercial and 384mA for military. Derate I_{OL} for number of outputs exceeding 8 turned on simultaneously.
- The test limit for this parameter is $\pm 5\mu\text{A}$ at $T_A = -55^{\circ}\text{C}$.

POWER SUPPLY CHARACTERISTICS

Symbol	Parameter	Test Conditions ⁽¹⁾		Min.	Typ. ⁽²⁾	Max.	Unit
ΔI_{CC}	Quiescent Power Supply Current TTL Inputs HIGH	$V_{CC} = \text{Max.}$ $V_{IN} = 3.4V^{(3)}$		—	0.5	2	mA
I_{CCD}	Dynamic Power Supply Current ⁽⁴⁾	$V_{CC} = \text{Max.}$ Outputs Open $\overline{G}BA = GAB = GND$ or V_{CC} One Input Toggling 50% Duty Cycle	$V_{IN} = V_{CC}$ $V_{IN} = GND$	—	0.15	0.25	mA/MHz
I_C	Total Power Supply Current ^(6,7)	$V_{CC} = \text{Max.}$ Outputs Open $\overline{G}BA = GAB = GND$ or V_{CC} One Bit Toggling at $f_i = 10\text{MHz}$ 50% Duty Cycle	$V_{IN} = V_{CC}$ $V_{IN} = GND$	—	1.5	3.5	mA
			$V_{IN} = 3.4V$ $V_{IN} = GND$	—	1.8	4.5	
		$V_{CC} = \text{Max.}$ Outputs Open $\overline{G}BA = GAB = GND$ or V_{CC} Eight Bits Toggling at $f_i = 2.5\text{MHz}$ 50% Duty Cycle	$V_{IN} = V_{CC}$ $V_{IN} = GND$	—	3	6 ⁽⁵⁾	
			$V_{IN} = 3.4V$ $V_{IN} = GND$	—	5	14.0 ⁽⁵⁾	

NOTES:

- For conditions shown as Max. or Min., use appropriate value specified under Electrical Characteristics for the applicable device type.
- Typical values are at $V_{CC} = 5.0V$, $+25^\circ\text{C}$ ambient.
- Per TTL driven input ($V_{IN} = 3.4V$); all other inputs at V_{CC} or GND .
- This parameter is not directly testable, but is derived for use in Total Power Supply Calculations.
- Values for these conditions are examples of the I_{CC} formula. These limits are guaranteed but not tested.
- $I_C = I_{QUIESCENT} + I_{INPUTS} + I_{DYNAMIC}$
 $I_C = I_{CC} + \Delta I_{CC} \cdot D_{HNT} + I_{CCD} (f_{CP}/2 + f_i N_i)$
 $I_{CC} = \text{Quiescent Current}$
 $\Delta I_{CC} = \text{Power Supply Current for a TTL High Input } (V_{IN} = 3.4V)$
 $D_H = \text{Duty Cycle for TTL Inputs High}$
 $N_T = \text{Number of TTL Inputs at } D_H$
 $I_{CCD} = \text{Dynamic Current Caused by an Output Transition Pair (HLH or LHL)}$
 $f_{CP} = \text{Clock Frequency for Register Devices (Zero for Non-Register Devices)}$
 $f_i = \text{Input Frequency}$
 $N_i = \text{Number of Inputs at } f_i$
 All currents are in milliamps and all frequencies are in megahertz.
- This test is performed with outputs tied to GND through a pull-down resistor.

SWITCHING CHARACTERISTICS OVER OPERATING RANGE

Symbol	Parameter	Condition ⁽¹⁾	IDT54/74FCT621T				IDT54/74FCT621AT				Unit
			Com'l.		Mil.		Com'l.		Mil.		
			Min. ⁽²⁾	Max.	Min. ⁽²⁾	Max.	Min. ⁽²⁾	Max.	Min. ⁽²⁾	Max.	
t_{PLH}	Propagation Delay A to B	$C_L = 50\text{pF}$ $R_L = 500\Omega$	5.5	13	5.5	13.5	5.5	12	5.5	12.5	ns
t_{PHL}			1.5	8.5	1.5	9.5	1.5	6.8	1.5	7.6	
t_{PLH}	Propagation Delay B to A		5.5	12.5	5.5	13	5.5	12	5.5	12.5	ns
t_{PHL}			1.5	8	1.5	9	1.5	6.4	1.5	7.2	
t_{PLH}	Propagation Delay $\overline{G}BA$ to A		5.5	14	5.5	14.5	5.5	13	5.5	13.5	ns
t_{PHL}			1.5	8.5	1.5	9.5	1.5	6.8	1.5	7.6	
t_{PLH}	Propagation Delay GAB to B		5.5	14	5.5	14.5	5.5	13	5.5	13.5	ns
t_{PHL}			1.5	8	1.5	9	1.5	6.4	1.5	7.2	

NOTES:

- See test circuit and waveforms.
- Minimum limits are guaranteed but not tested on Propagation Delays.

TEST CIRCUITS AND WAVEFORMS

TEST CIRCUITS FOR ALL OUTPUTS

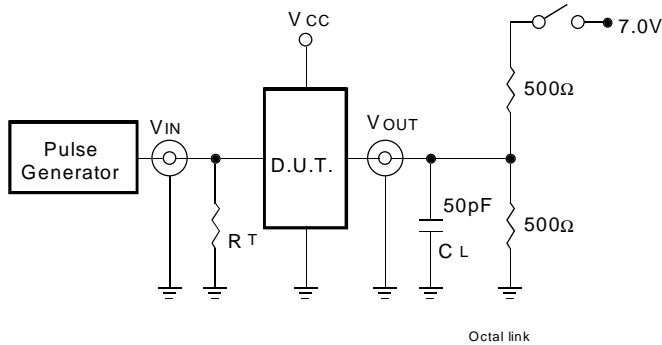

SWITCH POSITION

Test	Switch
Open Drain	Closed
Disable Low	
Enable Low	
All Other Tests	Open

DEFINITIONS:

CL = Load capacitance: includes jig and probe capacitance.

RT = Termination resistance: should be equal to ZOUT of the Pulse Generator.

SET-UP, HOLD, AND RELEASE TIMES

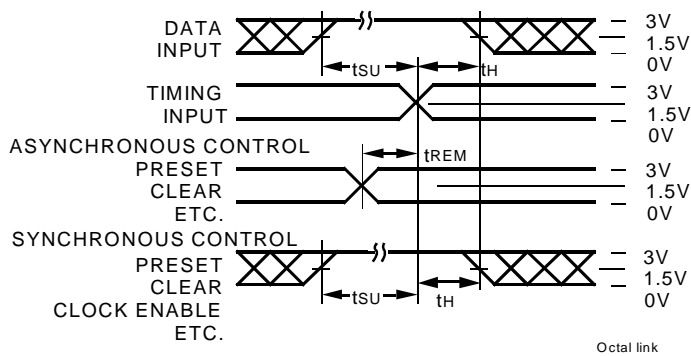

PULSE WIDTH

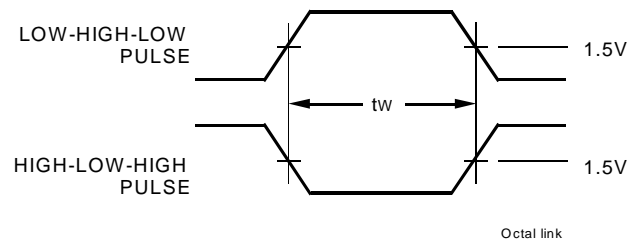

PROPAGATION DELAY

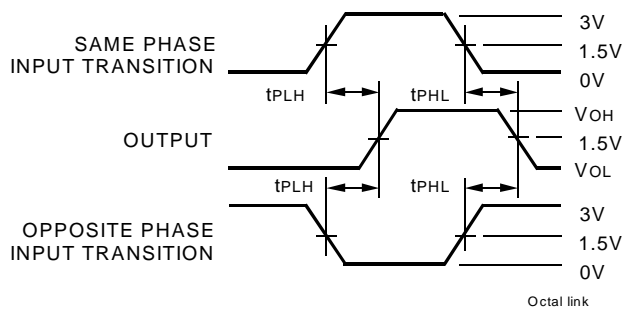

ENABLE AND DISABLE TIMES

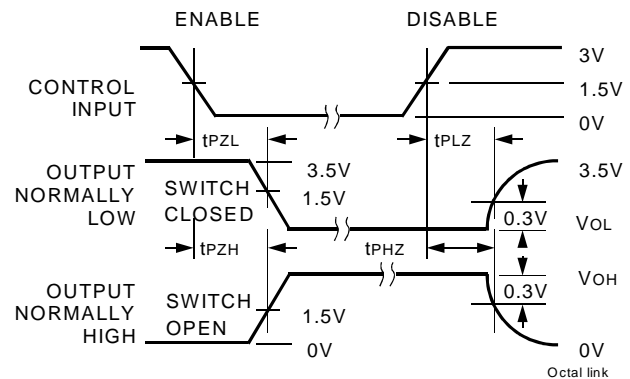

NOTES:

- Diagram shown for input Control Enable-LOW and input Control Disable-HIGH
- Pulse Generator for All Pulses: Rate $\leq 1.0\text{MHz}$; $t_f \leq 2.5\text{ns}$; $t_r \leq 2.5\text{ns}$

ORDERING INFORMATION

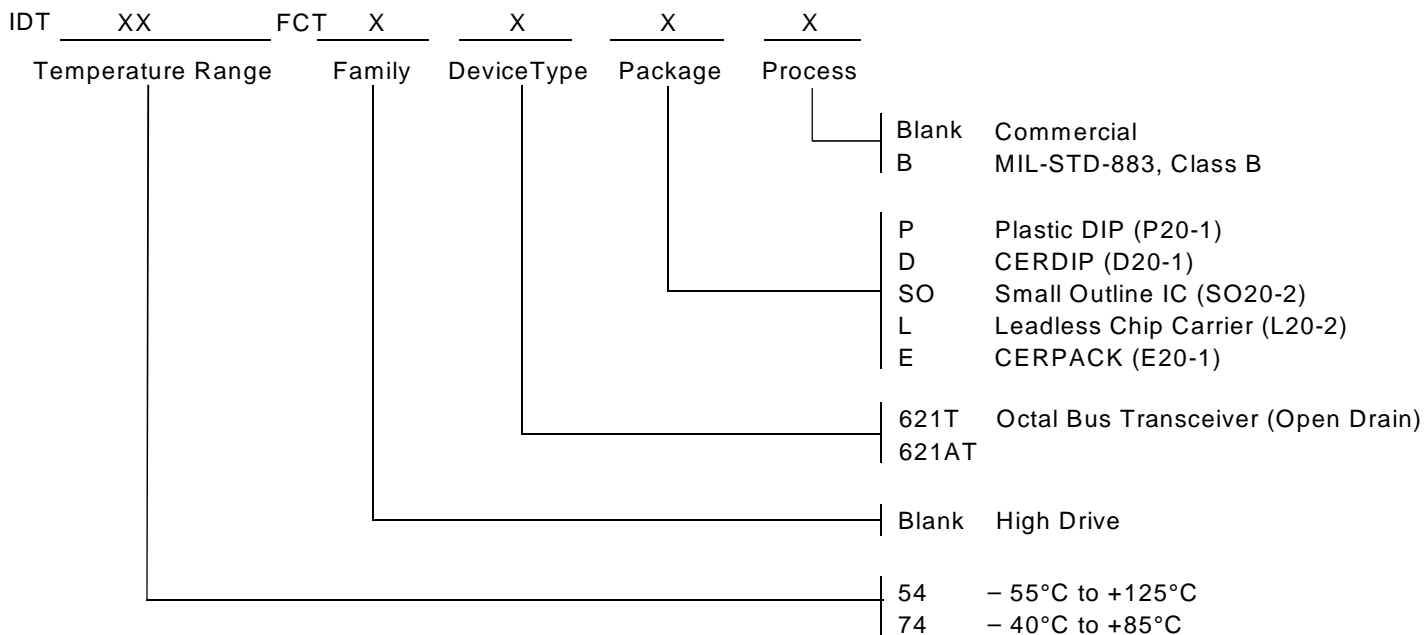

CORPORATE HEADQUARTERS
 2975 Stender Way
 Santa Clara, CA 95054

for SALES:
 800-345-7015 or 408-727-6116
 fax: 408-492-8674
 www.idt.com*

*To search for sales office near you, please click the sales button found on our home page or dial the 800# above and press 2.
 The IDT logo is a registered trademark of Integrated Device Technology, Inc.