

Stereo Headphone Driver with Mute

Features

- Operating voltage: 2.4V~6.0V
- Internal mute function to prevent power On/Off clicks
- Excellent power supply ripple rejection
- High slew rate
- Low total harmonic distortion
- Low power consumption
- Short circuit elimination
- Integrated voltage divider ($V_{DD}/2$) to eliminate external resistors
- Wide temperature operating range
- 8-pin SOP package

Applications

- CD-ROM/RW, DVD-ROM/RW
- PDA, MP3
- Portable Digital Audio
- Discman, Camcorders
- Headphone Amplifier

General Description

The HT82V736 is a class AB stereo earphone driver designed for portable digital audio application. It provides an integrated mute function to prevent popping sounds when power is turned on and off. In addition, the HT82V736 further integrates a voltage divider, and therefore the external resistors can be eliminated.

The HT82V736 has a fixed gain of 6dB so that external gain setting is unnecessary. It is fully pin and functionally compatible with BH3544 which is suitable for effective low cost applications.

Block Diagram

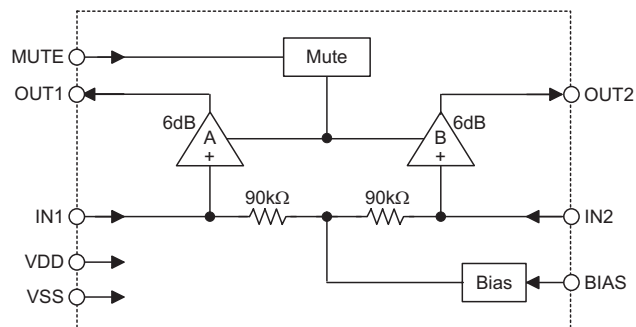

Pin Assignment

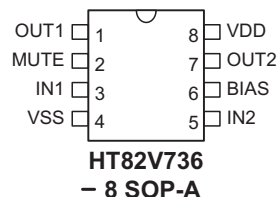

Pin Description

Pin No.	Pin Name	I/O	Description
1	OUT1	O	Channel 1 output pin
2	MUTE	I	Mute control (Mute On: low; Mute Off: high)
3	IN1	I	Audio input channel 1
4	VSS	—	Negative power supply, ground
5	IN2	I	Audio input channel 2
6	BIAS	I	$V_{DD}/2$ connected a capacitor to ground to eliminate power On/Off clicks
7	OUT2	O	Channel 2 output pin
8	VDD	—	Positive power supply

Absolute Maximum Ratings

Supply Voltage	$V_{SS}-0.3V$ to $V_{SS}+7.0V$	Storage Temperature	$-50^{\circ}C$ to $125^{\circ}C$
Input Voltage	$V_{SS}-0.3V$ to $V_{DD}+0.3V$	Operating Temperature	$-40^{\circ}C$ to $85^{\circ}C$

Note: These are stress ratings only. Stresses exceeding the range specified under "Absolute Maximum Ratings" may cause substantial damage to the device. Functional operation of this device at other conditions beyond those listed in the specification is not implied and prolonged exposure to extreme conditions may affect device reliability.

Electrical Characteristics $V_{IN}=0.5V_{rms}$; $V_{SS}=0V$; $f=1kHz$; $T_a=25^{\circ}C$; $R_L=32\Omega$ (unless otherwise specified)

Symbol	Parameter	Test Conditions		Min.	Typ.	Max.	Unit
		V_{DD}	Conditions				
V_{DD}	Supply Voltage	—	—	2.4	—	6.0	V
I_Q	Quiescent Current	5V	$V_{IN}=0V_{rms}$	—	2.5	4.0	mA
I_{MUTE}	Mute Current	5V	$V_{IN}=0V_{rms}$	—	100	—	μA
D.C. Characteristics							
V_{MUTE}	Mute Pin Control Voltage	5V	—	0.3	0.7	1.6	V
ΔA_V	Differential Channel Voltage Gain	5V	—	-0.5	0	0.5	dB
A_V	Voltage Gain	5V	—	—	6	—	dB
PSRR	Power Supply Rejection Ratio	5V	$f_{RR}=100Hz$; $V_{RR}=-20dBV$	65	75	—	dB
P_{O1}	Rated Output Power 1	5V	$R_L=32\Omega$, THD<0.1%	60	65	—	mW
P_{O2}	Rated Output Power 2	5V	$R_L=16\Omega$, THD<0.1%	110	115	—	mW
A.C. Characteristics							
THD	Total Harmonic Channel Distortion Factor	5V	BW=20~20kHz	—	0.02	0.05	%
ATT	Mute Attenuation	5V	$f=1kHz$	80	90	—	dB
X_{TALK}	Channel Separation	5V	$f=1kHz$	55	70	—	dB
V_{NO}	Output Noise Voltage	5V	$V_{IN}=0V_{rms}$, BW=20~20kHz	—	-97	-90	dBV

Typical Performance Characteristics

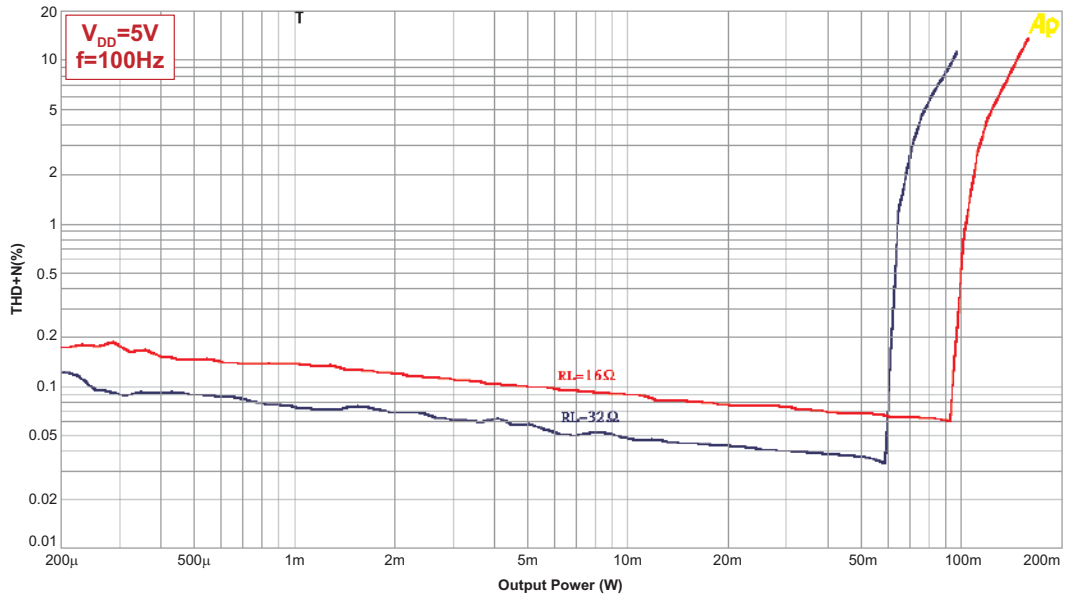

Fig.1 Total Harmonic Distortion vs. Output Power

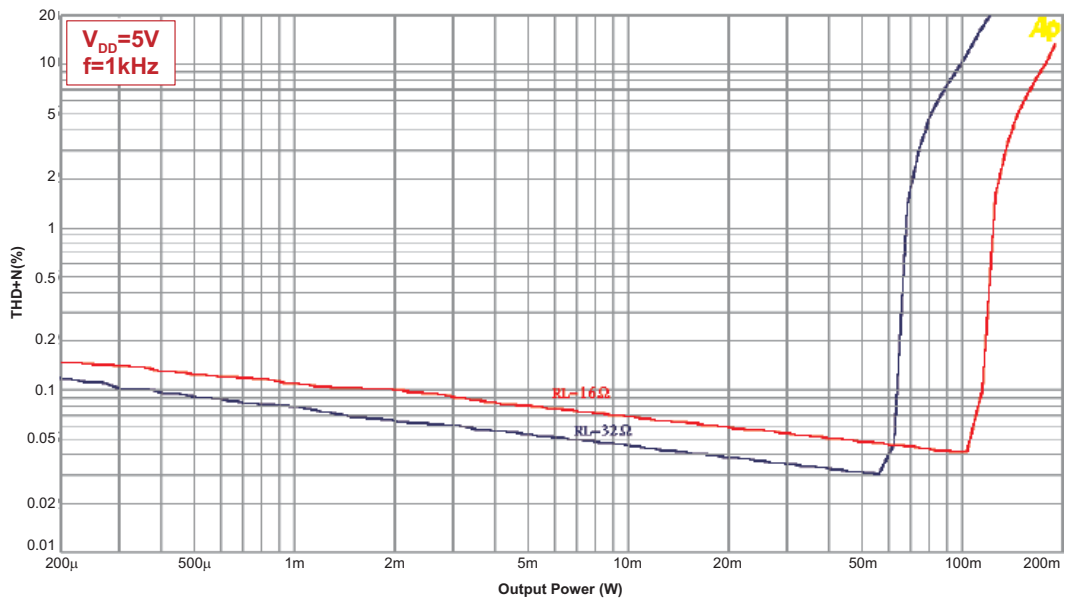

Fig.2 Total Harmonic Distortion vs. Output Power

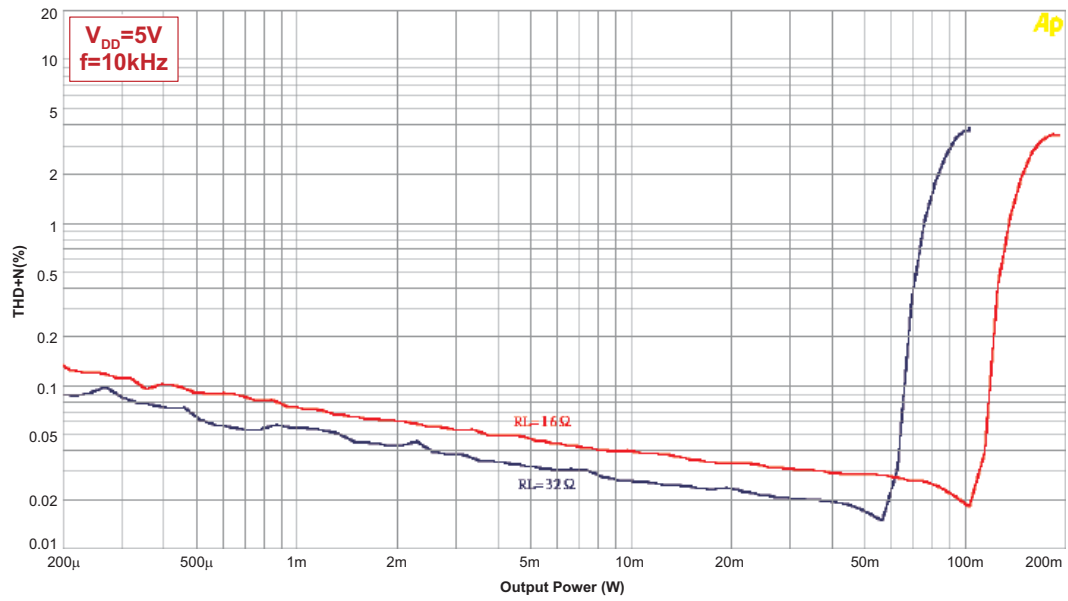

Fig.3 Total Harmonic Distortion vs. Output Power

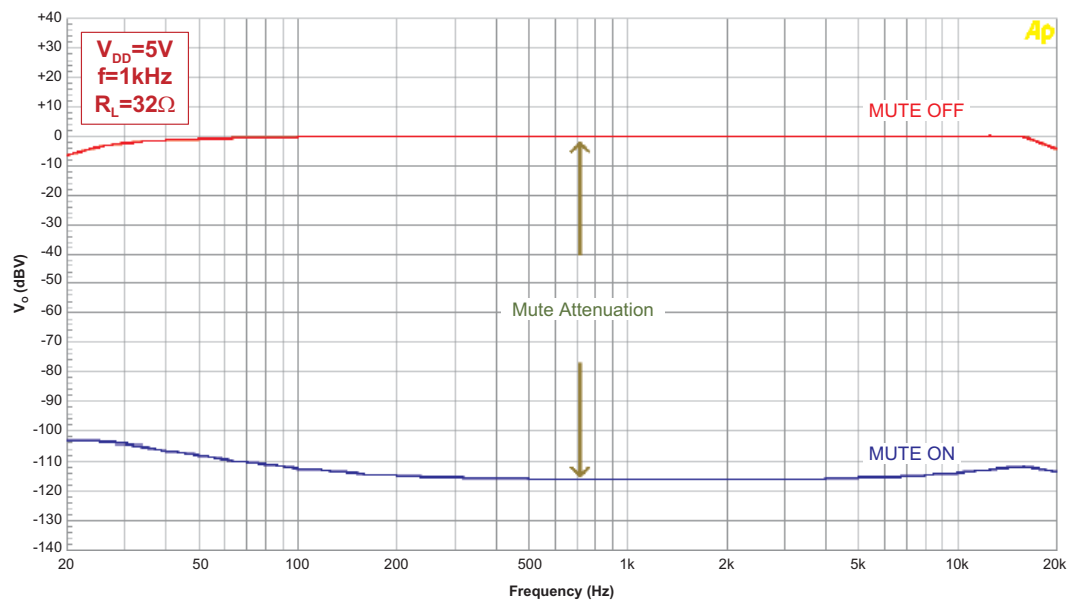

Fig.4 Mute Attenuation vs. Frequency

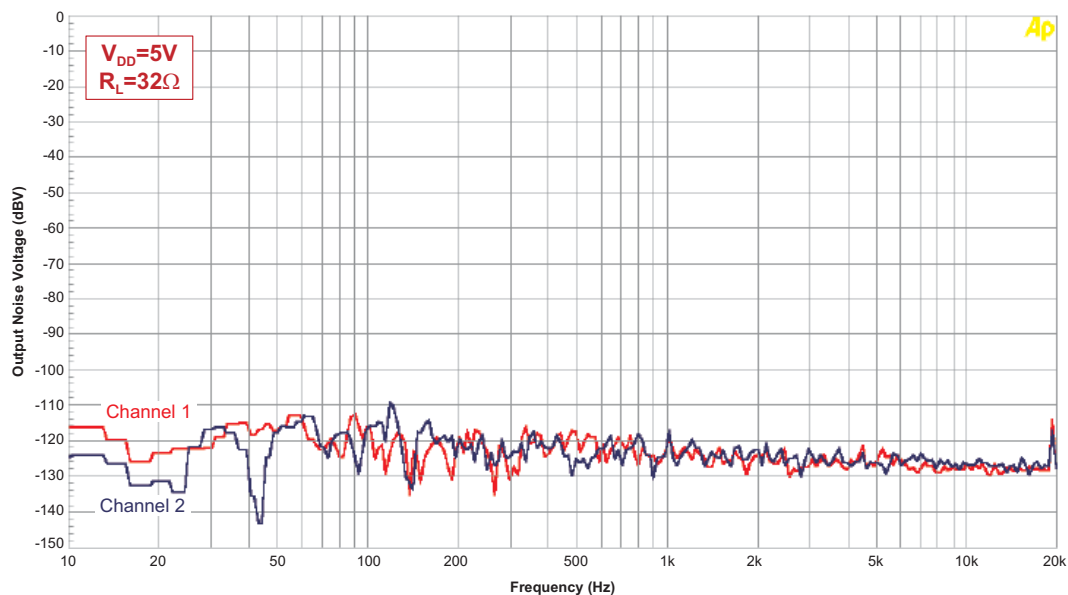
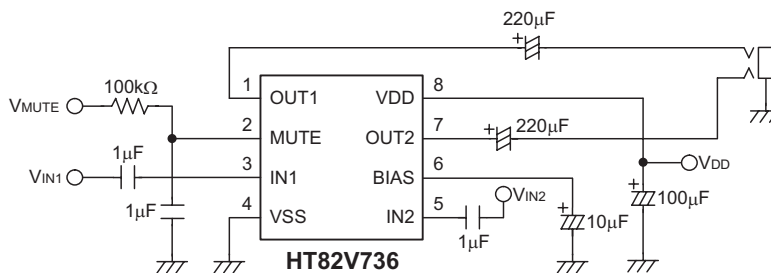

Fig.5 Output Noise Voltage vs. Frequency

Application Circuits



Package Information

8-pin SOP (150mil) Outline Dimensions

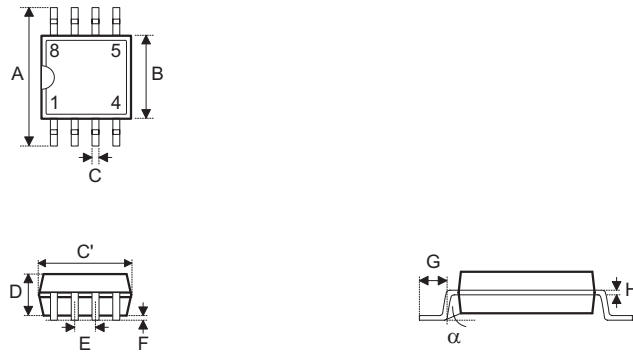

Symbol	Dimensions in mil		
	Min.	Nom.	Max.
A	228	—	244
B	149	—	157
C	14	—	20
C'	189	—	197
D	53	—	69
E	—	50	—
F	4	—	10
G	22	—	28
H	4	—	12
α	0°	—	10°

Product Tape and Reel Specifications

Reel Dimensions

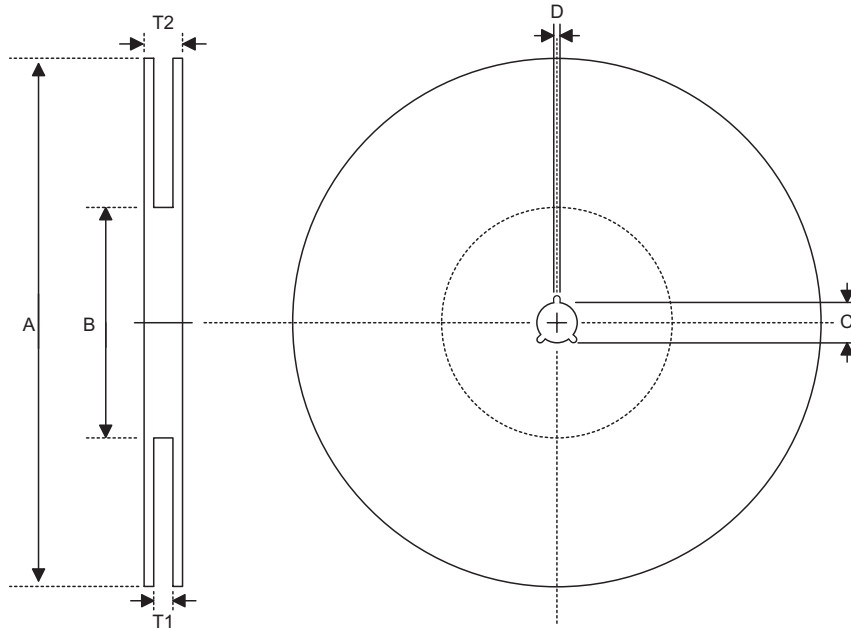

SOP 8N

Symbol	Description	Dimensions in mm
A	Reel Outer Diameter	330±1
B	Reel Inner Diameter	62.0±1.5
C	Spindle Hole Diameter	13.0+0.5 -0.2
D	Key Slit Width	2.0±0.5
T1	Space Between Flange	12.8+0.3 -0.2
T2	Reel Thickness	18.2±0.2

Carrier Tape Dimensions

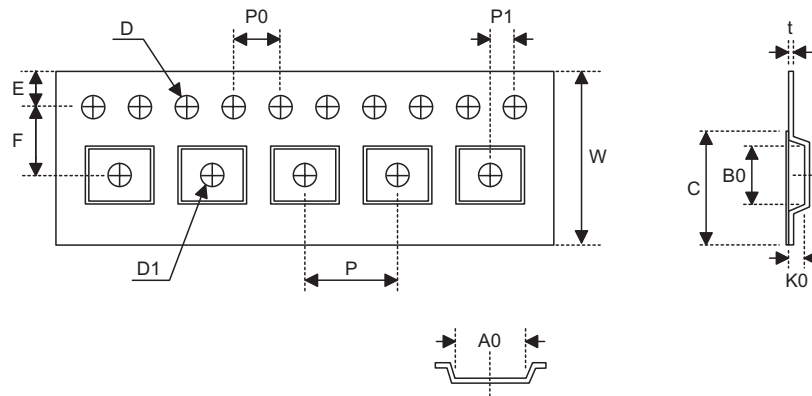

SOP 8N

Symbol	Description	Dimensions in mm
W	Carrier Tape Width	12.0+0.3 -0.1
P	Cavity Pitch	8.0±0.1
E	Perforation Position	1.75±0.1
F	Cavity to Perforation (Width Direction)	5.5±0.1
D	Perforation Diameter	1.55±0.1
D1	Cavity Hole Diameter	1.5+0.25
P0	Perforation Pitch	4.0±0.1
P1	Cavity to Perforation (Length Direction)	2.0±0.1
A0	Cavity Length	6.4±0.1
B0	Cavity Width	5.2±0.1
K0	Cavity Depth	2.1±0.1
t	Carrier Tape Thickness	0.3±0.05
C	Cover Tape Width	9.3

Holtek Semiconductor Inc. (Headquarters)

No.3, Creation Rd. II, Science Park, Hsinchu, Taiwan
Tel: 886-3-563-1999
Fax: 886-3-563-1189
<http://www.holtek.com.tw>

Holtek Semiconductor Inc. (Taipei Sales Office)

4F-2, No. 3-2, YuanQu St., Nankang Software Park, Taipei 115, Taiwan
Tel: 886-2-2655-7070
Fax: 886-2-2655-7373
Fax: 886-2-2655-7383 (International sales hotline)

Holtek Semiconductor Inc. (Shanghai Sales Office)

7th Floor, Building 2, No.889, Yi Shan Rd., Shanghai, China 200233
Tel: 021-6485-5560
Fax: 021-6485-0313
<http://www.holtek.com.cn>

Holtek Semiconductor Inc. (Shenzhen Sales Office)

43F, SEG Plaza, Shen Nan Zhong Road, Shenzhen, China 518031
Tel: 0755-8346-5589
Fax: 0755-8346-5590
ISDN: 0755-8346-5591

Holtek Semiconductor Inc. (Beijing Sales Office)

Suite 1721, Jinyu Tower, A129 West Xuan Wu Men Street, Xicheng District, Beijing, China 100031
Tel: 010-6641-0030, 6641-7751, 6641-7752
Fax: 010-6641-0125

Holmate Semiconductor, Inc. (North America Sales Office)

46712 Fremont Blvd., Fremont, CA 94538
Tel: 510-252-9880
Fax: 510-252-9885
<http://www.holmate.com>

Copyright © 2005 by HOLTEK SEMICONDUCTOR INC.

The information appearing in this Data Sheet is believed to be accurate at the time of publication. However, Holtek assumes no responsibility arising from the use of the specifications described. The applications mentioned herein are used solely for the purpose of illustration and Holtek makes no warranty or representation that such applications will be suitable without further modification, nor recommends the use of its products for application that may present a risk to human life due to malfunction or otherwise. Holtek's products are not authorized for use as critical components in life support devices or systems. Holtek reserves the right to alter its products without prior notification. For the most up-to-date information, please visit our web site at <http://www.holtek.com.tw>.