

### Features

- Operating voltage: 4.4V~5.25V
- Compatible with Microsoft Windows 2000 and 5-button Wheel Mouse
- Complete Universal Serial Bus specs V1.1 compatibility
- Serial Bus Interface Engine (SIE)
- USB transceiver
- Microsoft 3D Intelli mouse and IBM PS/2 mouse compatible
- Supports five buttons and three axes input
- Z axis can support two kinds of scroller input (optomechanical and mechanical)
- Single chip solution especially for USB mouse function
- HALT function and wake-up feature reduce power consumption
- Plug and Play functions
- Minimal external components
- 6MHz crystal oscillator for system clock
- 20-pin DIP package

### General Description

HT82M980A is a Plug and Play Windows 2000 and 5-button 3D USB+PS/2 Mouse controller. The HT82M980A can support the USB Standard Request as well as HID Class Request version 1.1. It is compatible with Microsoft Intelli 3D PS/2 mouse. The X/Y axis photo input with built-in Holtek's special dynamic photo-input resistor and Z axis can support two kinds of scroller in-

put, namely; mechanical and optomechanical. It requires minimal external components to implement 3D USB plus PS/2 mouse. All its features combined and make up this versatile Holtek 8-bit MCU with an on-chip USB interface logic. The USB is specified by the *Universal Serial Bus Specification V1.1*.

### Block Diagram

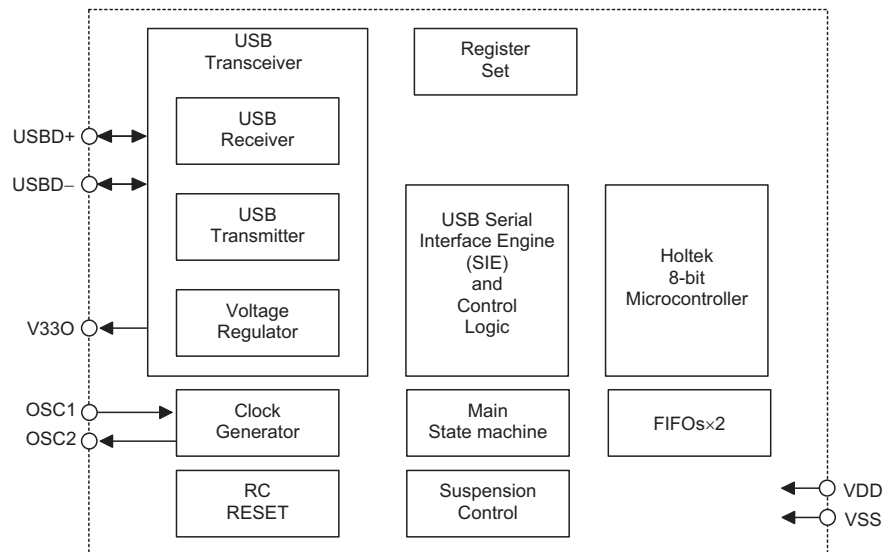

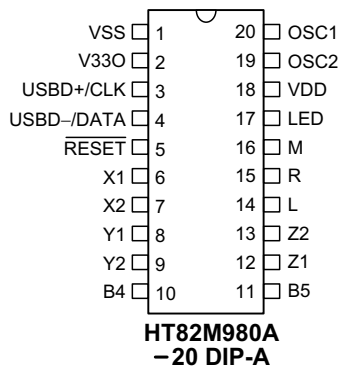
**Pin Assignment**

**Pin Description**

Pin No.	Pin Name	I/O	Description
<b>USB Interface (2 pins)</b>			
3	USB+/CLK	I/O	USB data plus or PS2 Clock, F/W auto-detect USB+ for USB, CLK for PS2
4	USB-/DATA	I/O	USB data minus or PS2 Data, F/W auto-detect USB- for USB, DATA for PS2
<b>General purpose I/O (11 pins)</b>			
6, 7	X1, X2	I	X-axis photo input with built-in Holtek's special dynamic photo input resistor
8, 9	Y1, Y2	I	Y-axis photo input with built-in Holtek's special dynamic photo input resistor
12, 13	Z1, Z2	I	Z-axis input supports two kinds of scroller input; optomechanical and mechanical
10, 11, 14, 15, 16	L, R, M, B4, B5	I	Input ports with pull-high resistor. These pads can function as Left, Right, Middle, B4 and B5 button input lines.
<b>Miscellaneous (7 pins)</b>			
1	VSS	—	Negative power supply, ground
2	V33O	O	3.3V voltage output
5	RESET	I	Chip reset input, low active
17	LED	I/O	Drives LED output
18	VDD	—	5V positive power supply
19	OSC2	O	6MHz OSC output
20	OSC1	I	6MHz OSC input

**Absolute Maximum Ratings**

Supply Voltage .....	-0.3V to 6V	Storage Temperature .....	-50°C to 125°C
MCU Input Voltage .....	$V_{SS}-0.3V$ to $V_{DD}+0.3V$	Operating Temperature .....	-25°C to 70°C
USB Input Voltage .....	$V_{SS}-0.3V$ to $V_{33O}+0.3V$		

Note: These are stress ratings only. Stresses exceeding the range specified under "Absolute Maximum Ratings" may cause substantial damage to the device. Functional operation of this device at other conditions beyond those listed in the specification is not implied and prolonged exposure to extreme conditions may affect device reliability.

**D.C. Characteristics**

Ta=25°C

Symbol	Parameter	Test Conditions		Min.	Typ.	Max.	Unit
		V <sub>DD</sub>	Conditions				
V <sub>DD</sub>	Operating Voltage	—	—	4.4	—	5.25	V
I <sub>DD</sub>	Operating Current (Crystal OSC)	5V	No load, f <sub>sys</sub> =6MHz	—	10	—	mA
			USB mode	—	3	—	mA
			PS/2 mode	—	3	—	mA
I <sub>SUS</sub>	USB Suspend Mode	5V	No load, system HALT	—	—	250	μA
V <sub>IL1</sub>	Input Low Voltage (X1, X2, Y1, Y2, Z1, Z2, L, M, R, B4, B5)	5V	—	0	—	1.0	V
V <sub>IH1</sub>	Input High Voltage (X1, X2, Y1, Y2, Z1, Z2, L, M, R, B4, B5)	5V	—	3.5	—	5	V
V <sub>IL2</sub>	Input Low Voltage (RESET)	5V	—	0	—	1.5	V
V <sub>IH2</sub>	Input High Voltage (RESET)	5V	—	3.5	—	5	V
V <sub>POR</sub>	Built-in Power on Reset V <sub>DD</sub> Detection Voltage	5V	—	—	3.7	—	V
I <sub>OL</sub>	Sink Current (LED)	5V	V <sub>OL</sub> =0.8V	—	50	—	mA

**A.C. Characteristics**

Ta=25°C

Symbol	Parameter	Test Conditions		Min.	Typ.	Max.	Unit
		V <sub>DD</sub>	Conditions				
f <sub>sys</sub>	System Clock (Crystal OSC)	5V	—	0	6000	—	kHz

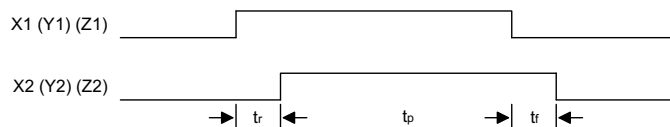
 Note: t<sub>sys</sub>=1/f<sub>sys</sub>
**Timing Diagram**
**X, Y Axis Photo-Coupler Crossed Width**

Note: For X, Y-axis tr, tp, tr &gt; 30μs

For Z-axis tr, tp, tr &gt; 1ms

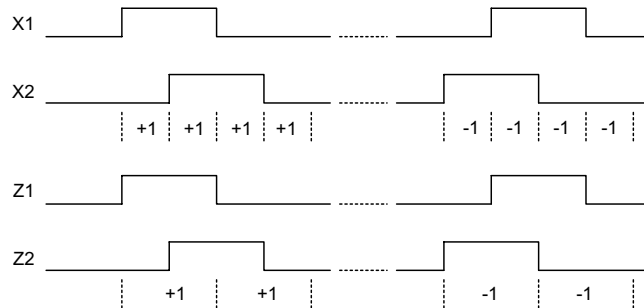
**X, Y, Z Axis Counting**

Application Circuits

This Application Circuit is for Reference Only

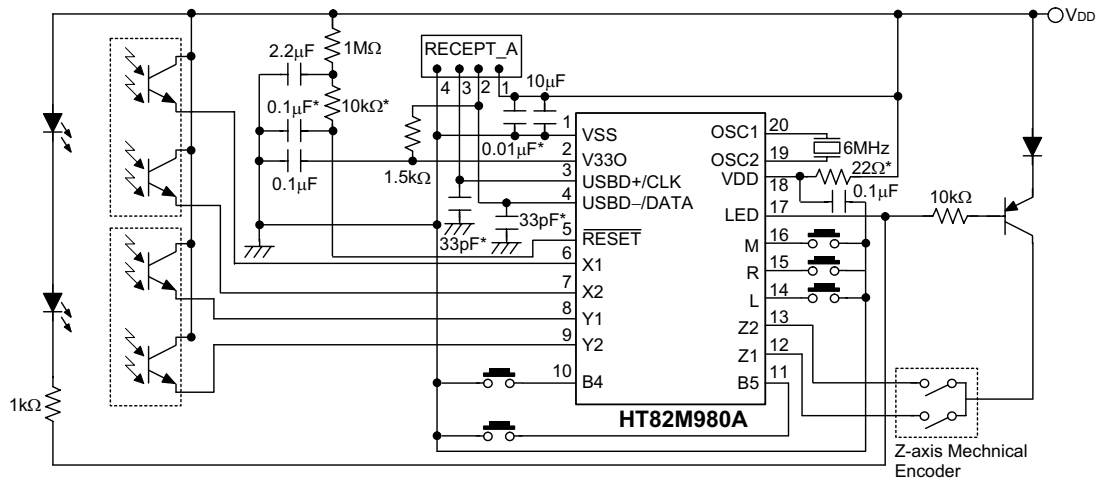
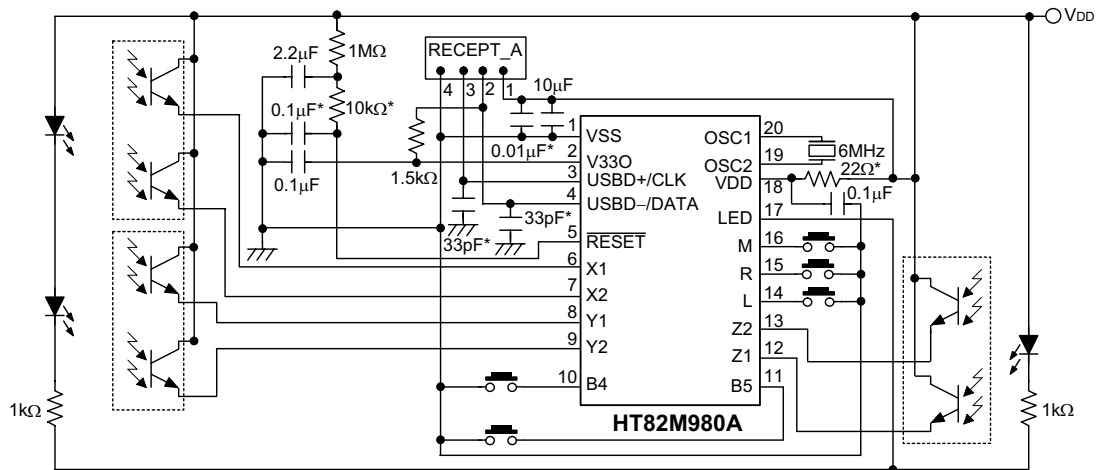

- Note: Layout 0.1µF capacitor, 22Ω resistor and 0.01µF capacitor as close to VDD pin as possible.
- Layout power plane and ground plane as large as possible.
- Place 0.1µF capacitor as close to  $\overline{\text{RESET}}$  pin as possible.
- Place 6MHz crystal as close to OSC1 and OSC2 pins as possible.
- Components with \* are used for EMC issue.

**Package Information**

20-pin DIP (300mil) Outline Dimensions

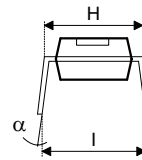
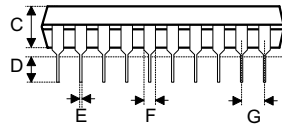
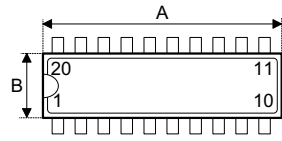

Symbol	Dimensions in mil		
	Min.	Nom.	Max.
A	1020	—	1045
B	240	—	260
C	125	—	135
D	125	—	145
E	16	—	20
F	50	—	70
G	—	100	—
H	295	—	315
I	335	—	375
$\alpha$	0°	—	15°

**Holtek Semiconductor Inc. (Headquarters)**

No.3, Creation Rd. II, Science Park, Hsinchu, Taiwan  
Tel: 886-3-563-1999  
Fax: 886-3-563-1189  
<http://www.holtek.com.tw>

**Holtek Semiconductor Inc. (Taipei Sales Office)**

4F-2, No. 3-2, YuanQu St., Nankang Software Park, Taipei 115, Taiwan  
Tel: 886-2-2655-7070  
Fax: 886-2-2655-7373  
Fax: 886-2-2655-7383 (International sales hotline)

**Holtek Semiconductor Inc. (Shanghai Sales Office)**

7th Floor, Building 2, No.889, Yi Shan Rd., Shanghai, China 200233  
Tel: 021-6485-5560  
Fax: 021-6485-0313  
<http://www.holtek.com.cn>

**Holtek Semiconductor Inc. (Shenzhen Sales Office)**

43F, SEG Plaza, Shen Nan Zhong Road, Shenzhen, China 518031  
Tel: 0755-8346-5589  
Fax: 0755-8346-5590  
ISDN: 0755-8346-5591

**Holtek Semiconductor Inc. (Beijing Sales Office)**

Suite 1721, Jinyu Tower, A129 West Xuan Wu Men Street, Xicheng District, Beijing, China 100031  
Tel: 010-6641-0030, 6641-7751, 6641-7752  
Fax: 010-6641-0125

**Holmate Semiconductor, Inc. (North America Sales Office)**

46712 Fremont Blvd., Fremont, CA 94538  
Tel: 510-252-9880  
Fax: 510-252-9885  
<http://www.holmate.com>

Copyright © 2003 by HOLTEK SEMICONDUCTOR INC.

The information appearing in this Data Sheet is believed to be accurate at the time of publication. However, Holtek assumes no responsibility arising from the use of the specifications described. The applications mentioned herein are used solely for the purpose of illustration and Holtek makes no warranty or representation that such applications will be suitable without further modification, nor recommends the use of its products for application that may present a risk to human life due to malfunction or otherwise. Holtek's products are not authorized for use as critical components in life support devices or systems. Holtek reserves the right to alter its products without prior notification. For the most up-to-date information, please visit our web site at <http://www.holtek.com.tw>.