

Features

- Operating voltage: 3.6V~5.0V
- Operating frequency: 3.58MHz~12MHz (typ. 11.059MHz)
- 32 bidirectional I/O lines
- Two 16-bit programmable timer/event counters with overflow interrupts
- Watchdog Timer
- Built-in 8-bit MCU with 576×8 bits RAM
- Built-in 128K×16-bit ROM for program/data shared
- Two High D/A converter resolution: 16 bits
- Polyphonic up to 16 notes
- Independent pan and volume mix can be assigned to each sound component
- Sampling rate of 44.1kHz as 11.059MHz for system frequency
- Eight-level subroutine nesting
- HALT function and wake-up feature to reduce power consumption
- Bit manipulation instructions
- 16-bit table read instructions
- 63 powerful instructions
- All instructions in 1 or 2 machine cycles
- 28-pin SOP, 56-pin SSOP package

General Description

The HT36B2 is an 8-bit high performance RISC-like microcontroller specifically designed for music applications. It provides an 8-bit MCU and a 16 channel wavetable synthesizer. The program ROM is composed of both program control codes and wavetable voice codes, and can be easily programmed.

The HT36B2 has a built-in 8-bit microprocessor which programs the synthesizer to generate the melody by setting the special register from 20H~2AH. A HALT feature is provided to reduce power consumption.

Block Diagram

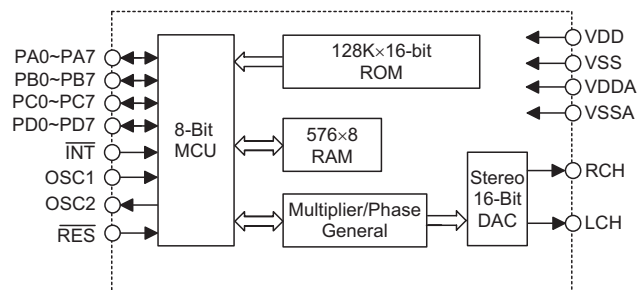

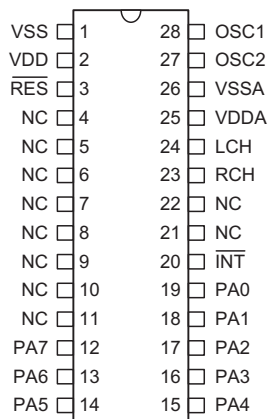
Pin Assignment

HT36B2
- 28 SOP-A

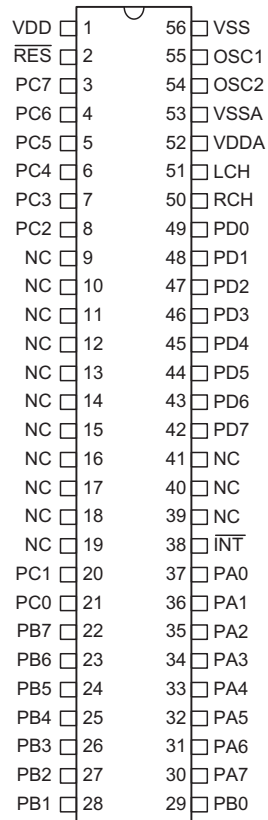

HT36B2
- 56 SSOP-A

Pad Assignment

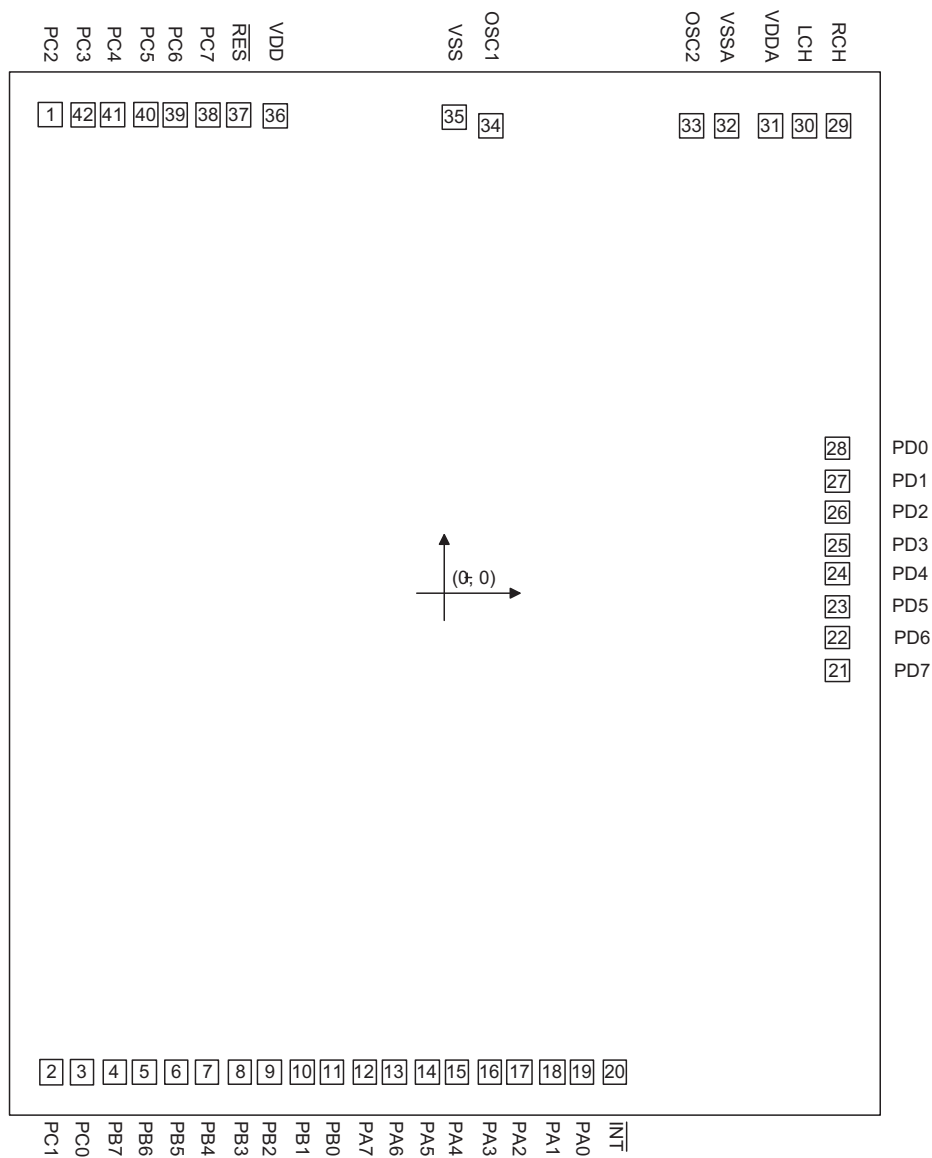

Chip size: 117.1 × 139.8 (mil)

* The IC substrate should be connected to VSS in the PCB layout artwork.

Pad Coordinates

 Unit: μm

Pad No.	X	Y	Pad No.	X	Y
1	-1327.608	1607.250	22	1320.992	-146.680
2	-1321.808	-1607.630	23	1320.992	-46.680
3	-1221.808	-1607.630	24	1320.992	63.920
4	-1111.208	-1607.630	25	1320.992	163.920
5	-1011.208	-1607.630	26	1320.992	274.520
6	-900.608	-1607.630	27	1320.992	374.520
7	-800.608	-1607.630	28	1320.992	485.120
8	-690.008	-1607.630	29	1324.492	1571.300
9	-590.008	-1607.630	30	1211.492	1571.300
10	-479.408	-1607.630	31	1099.052	1571.300
11	-379.408	-1607.630	32	950.392	1571.300
12	-268.808	-1607.630	33	833.168	1571.200
13	-168.808	-1607.630	34	155.316	1571.200
14	-58.208	-1607.630	35	34.192	1604.750
15	41.792	-1607.630	36	-572.908	1604.750
16	152.392	-1607.630	37	-694.032	1607.250
17	252.392	-1607.630	38	-795.808	1607.250
18	362.992	-1607.630	39	-906.408	1607.250
19	462.992	-1607.630	40	-1006.408	1607.250
20	571.392	-1607.630	41	-1117.008	1607.250
21	1320.992	-257.280	42	-1217.008	1607.250

Pad Description

Pad Name	I/O	Internal Connection	Function
PA0~PA7	I/O	Pull-High or None	Bidirectional 8-bit Input/Output port, wake-up by mask option
PB0~PB7	I/O	Pull-High or None	Bidirectional 8-bit Input/Output port
PC0~PC7	I/O	Pull-High or None	Bidirectional 8-bit Input/Output port
PD0~PD7	I/O	Pull-High or None	Bidirectional 8-bit Input/Output port
$\overline{\text{INT}}$	I	Pull-High	External interrupt
RCH	O	—	R channel audio output
LCH	O	—	L channel audio output
VDDA	—	—	DAC power supply
VSSA	—	—	Negative power supply of DAC, ground
OSC1 OSC2	I O	—	OSC1 and OSC2 are connected to an RC network or a crystal (by mask option) for the internal system clock. In the case of RC operation, OSC2 is the output terminal for 1/8 system clock. The system clock may come from the crystal, the two pins cannot be floating.
VSS	—	—	Negative power supply, ground
VDD	—	—	Positive power supply
$\overline{\text{RES}}$	I	—	Reset input, active low

Absolute Maximum Ratings

Supply Voltage $V_{SS}-0.3V$ to $V_{SS}+6V$ Storage Temperature $-50^{\circ}C$ to $125^{\circ}C$
 Input Voltage $V_{SS}-0.3V$ to $V_{DD}+0.3V$ Operating Temperature $-25^{\circ}C$ to $70^{\circ}C$

Note: These are stress ratings only. Stresses exceeding the range specified under "Absolute Maximum Ratings" may cause substantial damage to the device. Functional operation of this device at other conditions beyond those listed in the specification is not implied and prolonged exposure to extreme conditions may affect device reliability.

D.C. Characteristics

Ta=25°C

Symbol	Parameter	Test Conditions		Min.	Typ.	Max.	Unit
		V _{DD}	Conditions				
V _{DD}	Operating Voltage	—	—	3.6	4.5	5.5	V
I _{DD}	Operating Current	4.5V	No load, f _{OSC} =11.0592MHz	—	16	32	mA
I _{STB}	Standby Current (WDT Disabled)	4.5V	No load, System HALT	—	1	3	μA
I _{OH}	I/O Ports Source Current	4.5V	V _{OH} =4.5V	5	—	—	mA
I _{OL}	I/O Ports Sink Current	4.5V	V _{OL} =0.5V	5	—	—	mA
V _{IH}	Input High Voltage for I/O Ports	4.5V	—	0.8V _{DD}	—	V _{DD}	V
V _{IL}	Input Low Voltage for I/O Ports	4.5V	—	0	—	0.2V _{DD}	V
R _{PH}	Pull-High Resistance of I/O Ports (INT)	4.5V	V _{IL} =0V	—	30	—	kΩ

A.C. Characteristics

Symbol	Parameter	Test Conditions		Min.	Typ.	Max.	Unit
		V _{DD}	Conditions				
MCU interface							
f _{OSC}	System Frequency	5V	11.059MHz crystal	—	11.059	—	MHz
f _{SYS}	System Clock	5V	—	8	—	12	MHz
t _{WDT}	Watchdog Time-Out Period (RC)	—	Without WDT prescaler	9	17	35	ms
t _{RES}	External Reset Low Pulse Width	—	—	1	—	—	μs

Application Circuit

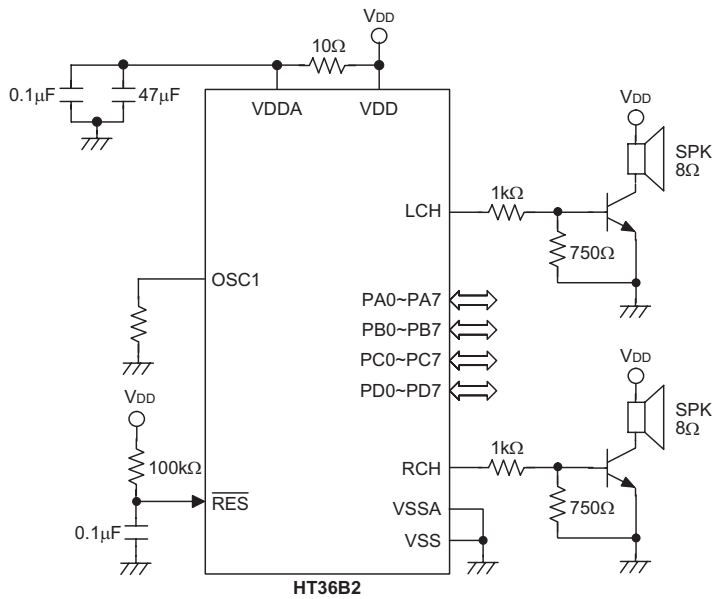
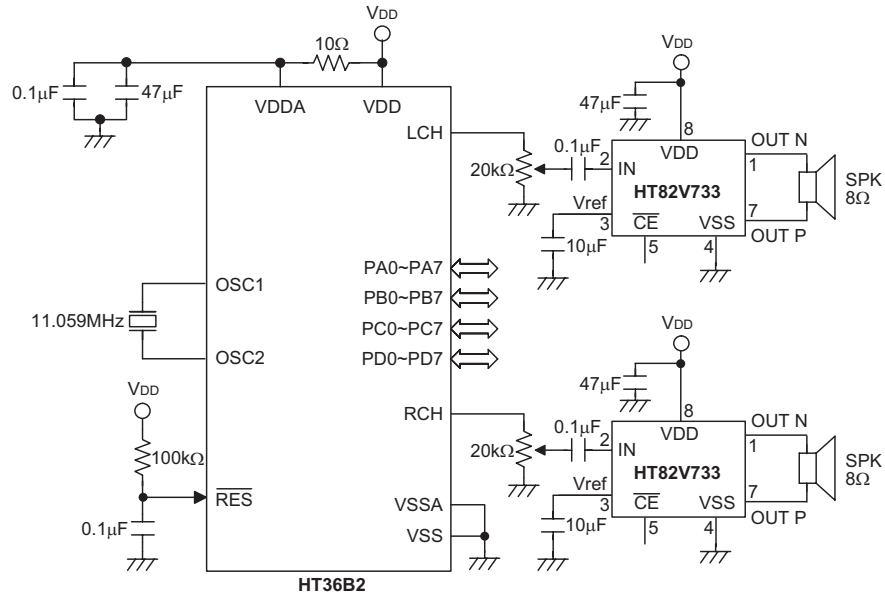

Package Information

28-pin SOP (300mil) Outline Dimensions

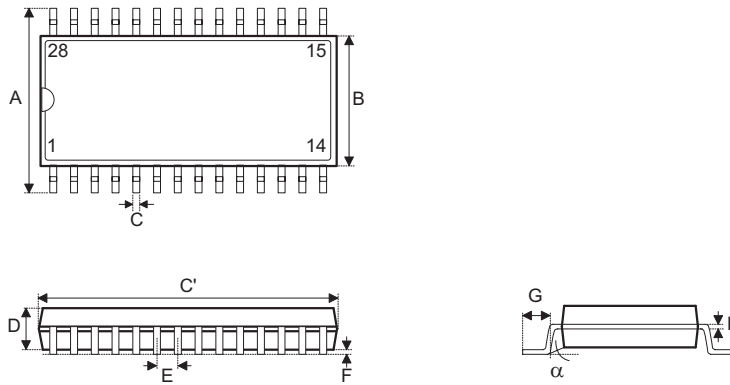

Symbol	Dimensions in mil		
	Min.	Nom.	Max.
A	394	—	419
B	290	—	300
C	14	—	20
C'	697	—	713
D	92	—	104
E	—	50	—
F	4	—	—
G	32	—	38
H	4	—	12
α	0°	—	10°

56-pin SSOP (300mil) Outline Dimensions

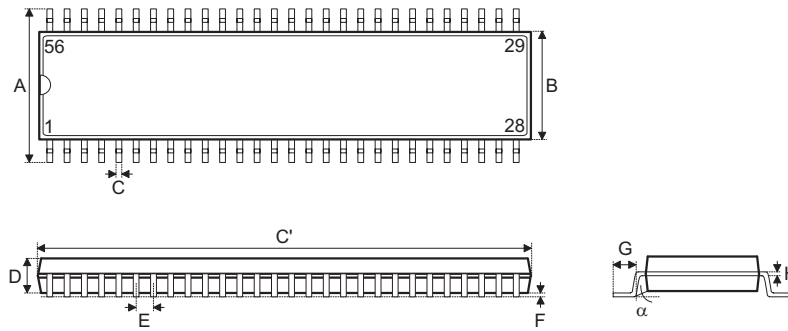

Symbol	Dimensions in mil		
	Min.	Nom.	Max.
A	395	—	420
B	291	—	299
C	8	—	12
C'	720	—	730
D	89	—	99
E	—	25	—
F	4	—	10
G	25	—	35
H	4	—	12
α	0°	—	8°

Product Tape and Reel Specifications

Reel Dimensions

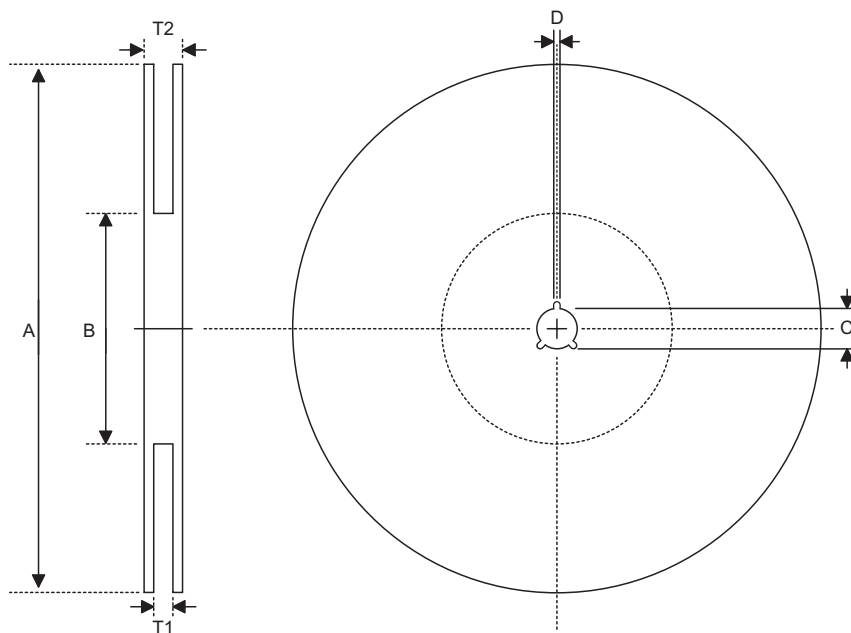

SOP 28W (300mil)

Symbol	Description	Dimensions in mm
A	Reel Outer Diameter	330±1.0
B	Reel Inner Diameter	62±1.5
C	Spindle Hole Diameter	13.0+0.5 -0.2
D	Key Slit Width	2.0±0.5
T1	Space Between Flange	24.8+0.3 -0.2
T2	Reel Thickness	30.2±0.2

Carrier Tape Dimensions

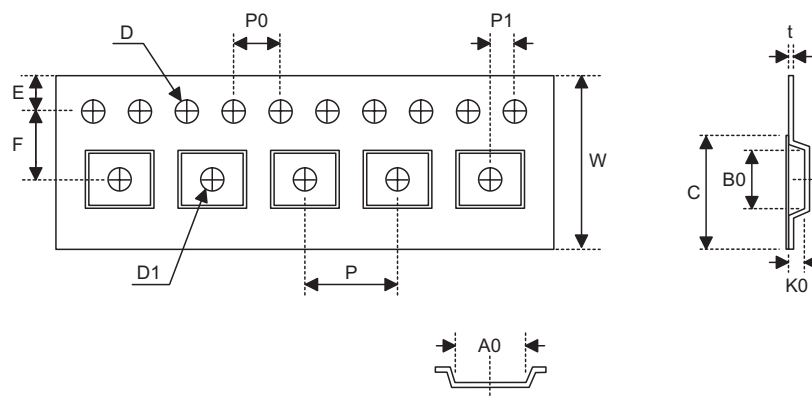

SOP 28W (300mil)

Symbol	Description	Dimensions in mm
W	Carrier Tape Width	24.0±0.3
P	Cavity Pitch	12.0±0.1
E	Perforation Position	1.75±0.1
F	Cavity to Perforation (Width Direction)	11.5±0.1
D	Perforation Diameter	1.5+0.1
D1	Cavity Hole Diameter	1.5+0.25
P0	Perforation Pitch	4.0±0.1
P1	Cavity to Perforation (Length Direction)	2.0±0.1
A0	Cavity Length	10.85±0.1
B0	Cavity Width	18.34±0.1
K0	Cavity Depth	2.97±0.1
t	Carrier Tape Thickness	0.35±0.01
C	Cover Tape Width	21.3

Holtek Semiconductor Inc. (Headquarters)

No.3, Creation Rd. II, Science Park, Hsinchu, Taiwan
Tel: 886-3-563-1999
Fax: 886-3-563-1189
<http://www.holtek.com.tw>

Holtek Semiconductor Inc. (Taipei Sales Office)

4F-2, No. 3-2, YuanQu St., Nankang Software Park, Taipei 115, Taiwan
Tel: 886-2-2655-7070
Fax: 886-2-2655-7373
Fax: 886-2-2655-7383 (International sales hotline)

Holtek Semiconductor Inc. (Shanghai Sales Office)

7th Floor, Building 2, No.889, Yi Shan Rd., Shanghai, China 200233
Tel: 021-6485-5560
Fax: 021-6485-0313
<http://www.holtek.com.cn>

Holtek Semiconductor Inc. (Shenzhen Sales Office)

43F, SEG Plaza, Shen Nan Zhong Road, Shenzhen, China 518031
Tel: 0755-8346-5589
Fax: 0755-8346-5590
ISDN: 0755-8346-5591

Holtek Semiconductor Inc. (Beijing Sales Office)

Suite 1721, Jinyu Tower, A129 West Xuan Wu Men Street, Xicheng District, Beijing, China 100031
Tel: 010-6641-0030, 6641-7751, 6641-7752
Fax: 010-6641-0125

Holmate Semiconductor, Inc. (North America Sales Office)

46712 Fremont Blvd., Fremont, CA 94538
Tel: 510-252-9880
Fax: 510-252-9885
<http://www.holmate.com>

Copyright © 2003 by HOLTEK SEMICONDUCTOR INC.

The information appearing in this Data Sheet is believed to be accurate at the time of publication. However, Holtek assumes no responsibility arising from the use of the specifications described. The applications mentioned herein are used solely for the purpose of illustration and Holtek makes no warranty or representation that such applications will be suitable without further modification, nor recommends the use of its products for application that may present a risk to human life due to malfunction or otherwise. Holtek's products are not authorized for use as critical components in life support devices or systems. Holtek reserves the right to alter its products without prior notification. For the most up-to-date information, please visit our web site at <http://www.holtek.com.tw>.