

KA3030D

6-Channel Motor Drive IC

Features

- Wide operating supply voltage range: 4.5V ~ 13.2V
- Built in TSD (Thermal shutdown) circuit
- Built in protection circuit for under or high voltage
- Built in mute circuit
- Built in speed control circuit
- Built in level shift (V-I converter)

Description

The KA3030D is a monolithic integrated circuit, suitable for a 6-ch motor drivers which drive focus actuator, tracking actuator, sled motor, spindle motor, loading motor and changer of CD system.

28-SSOPH-375

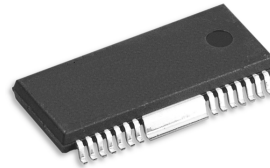

Typical Application

- Compact disk player (CDP)
- Video compact disk player (VCD)
- Automotive compact disk player (CDP)

Ordering Information

Device	Package	Operating Temp.
KA3030D	28-SSOPH-375	-25°C ~ +75°C
KA3030DTF	28-SSOPH-375	-25°C ~ +75°C

Pin Assignments

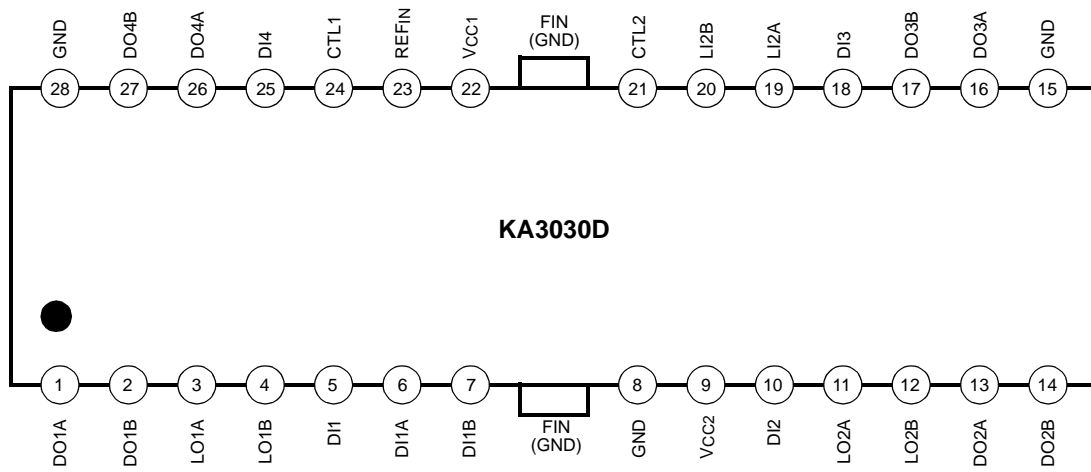

Pin Definitions

Pin Number	Pin Name	I/O	Pin Function Description
1	DO1A	O	Drive output 1A (-)
2	DO1B	O	Drive output 1B (+)
3	LO1A	O	Logic output 1A
4	LO1B	O	Logic output 1B
5	DI1	I	Drive input 1
6	DI1A	I	Logic input 1A
7	DI1B	I	Logic input 1B
8	GND	-	Ground
9	VCC2	-	Supply voltage 2
10	DI2	I	Drive input 2
11	LO2A	O	Logic output 2A
12	LO2B	O	Logic output 2B
13	DO2A	O	Drive output 2A (+)
14	DO2B	O	Drive output 2B (-)
15	GND	-	Ground
16	DO3A	O	Drive output 3A (-)
17	DO3B	O	Drive output 3B (+)
18	DI3	I	Drive input 3
19	LI2A	I	Logic input 2A
20	LI2B	I	Logic input 2B
21	CTL2	I	Speed control 2
22	VCC1	-	Power supply 1
23	REFIN	I	Reference & mute input
24	CTL1	I	Speed control 1
25	DI4	I	Drive input 4
26	DO4A	O	Drive output 4A (+)
27	DO4B	O	Drive output 4B (-)
28	GND	-	Ground

Internal Block Diagram

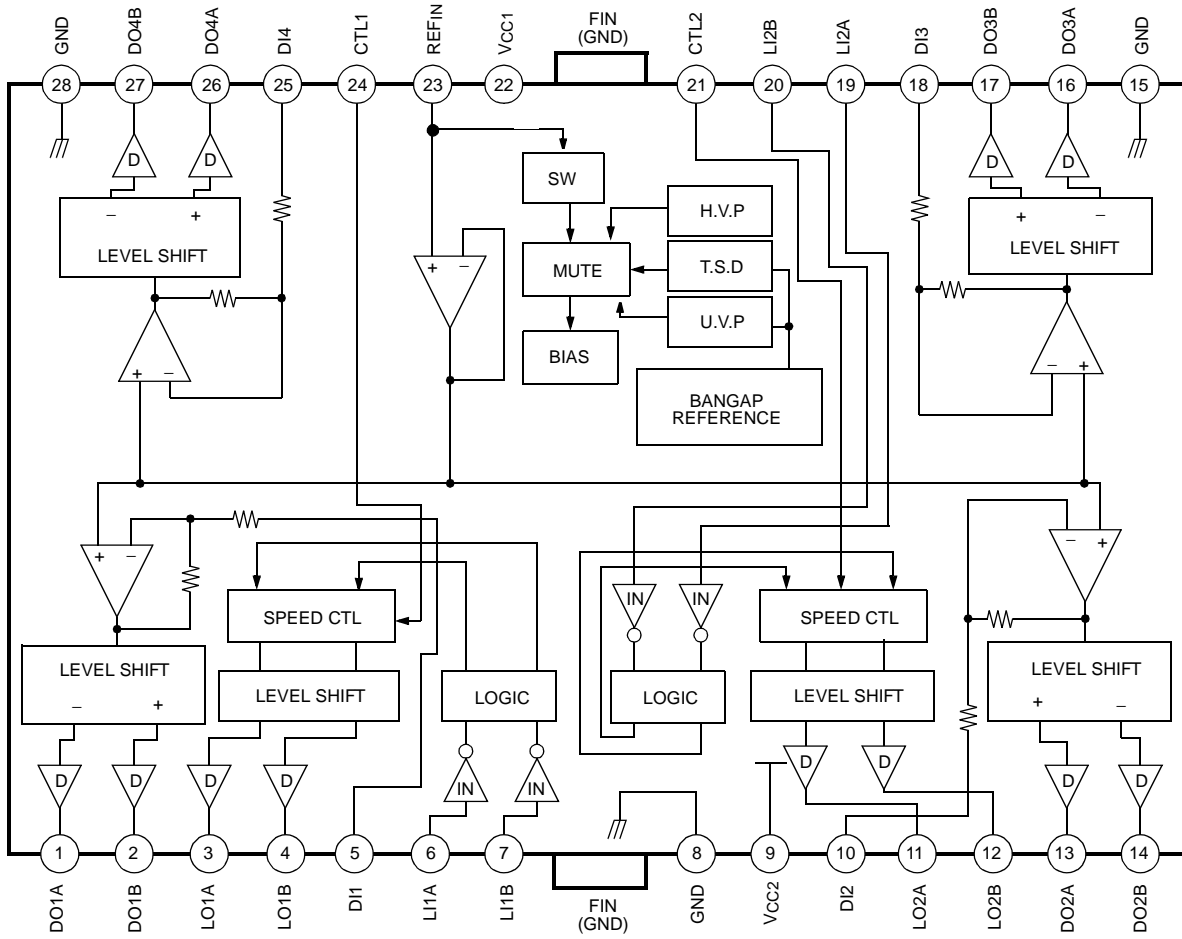

Equivalent Circuit

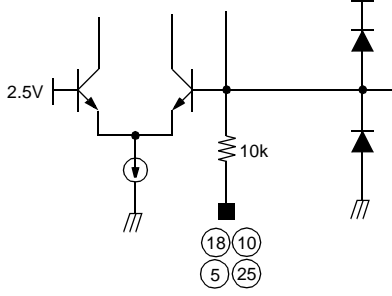
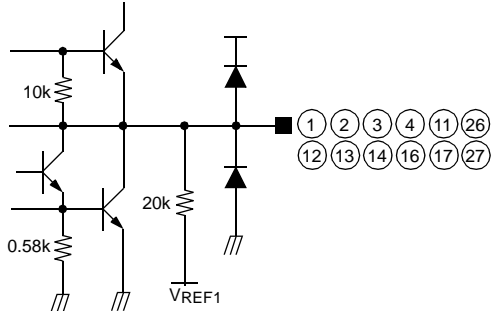
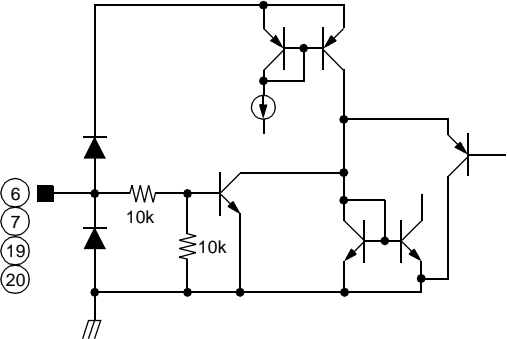
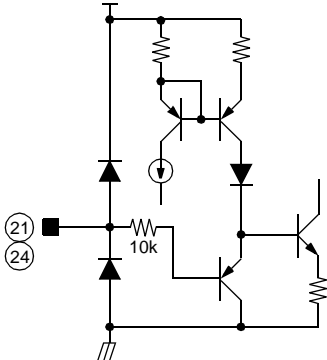
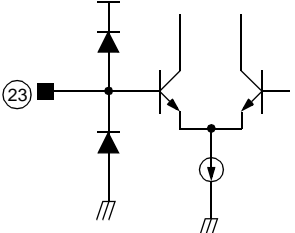
Driver input (Except for loading motor driver)	Driver output
	
Loading motor driver input	Loading motor speed control input
	
Bias	
	

Absolute Maximum Ratings (Ta = 25°C)

Parameter	Symbol	Value	Unit
Maximum supply voltage	VCCMAX	18	V
Power dissipation	PD	1700 ^{note}	mW
Maximum output current	IOMAX	1	A
Operating temperature	TOPR	-25 ~ 75	°C
Storage temperature	TSTG	-55 ~ 150	°C

NOTE:

1. When mounted on 76mm × 114mm × 1.57mm PCB (Phenolic resin material).
2. Power dissipation reduces 13.6mW / °C for using above Ta=25°C
3. Do not exceed Pd and SOA.

Power Dissipation Curve

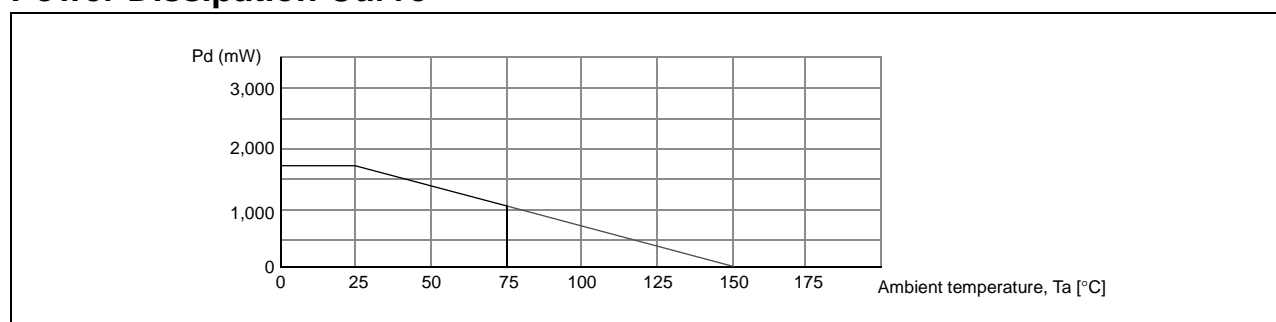

Recommended Operating Condition (Ta = 25°C)

Parameter	Symbol	Value	Unit
Operating supply voltage ^{note}	VCC	4.5 ~ 13.2	V

NOTE:

- VCC1 (pin 22) ≤ VCC2 (pin 9)
 VCC1 (pin 22) must not exceed VCC2 (pin 9)

Electrical Characteristics

(Ta=25°C, VCC=8V, unless otherwise specified)

Parameter	Symbol	Conditions	Min.	Typ.	Max.	Units
Quiescent circuit current	ICC	Under no load	8	11	14	mA
Mute on current	IMUTE	V _{PIN23} =GND	-	3	6	mA
Mute on voltage	V _{MON}	-	-	-	0.5	V
Mute off voltage	V _{MOFF}	-	2	-	-	V
Under voltage protection	V _{UVO}	-	-	-	4	V
High voltage protection	V _{HVP}	-	19	-	-	V
FOCUS, TRACKING, SPINDLE, SLED, DRIVE PART (RL=8Ω)						
Input offset voltage	V _{IO}	-	-20	-	20	mV
Output offset voltage	V _{OO}	V _{IN} =2.5V	-40	-	40	mV
Max. output voltage 1	V _{OM1}	V _{CC} =5V	2.4	3	-	V
Close loop voltage gain 1	AV _{F1}	V _{CC} =5V, V _{IN} =0.1VRMS	7.5	9	10.5	dB
Max. output voltage 2	V _{OM2}	V _{CC} =8V	4.7	5.7	-	V
Close loop voltage gain 2	AV _{F2}	V _{CC} =8V, V _{IN} =0.1VRMS	7.5	9	10.5	dB
Ripple rejection ratio	RR	V _{IN} =0.1VRMS, f=100Hz	40	60	-	dB
Slew rate	SR	Square waveform, V _{out} =3Vp-p, f=100Hz	-	0.8	-	V/μs
LOADING, CHANGER DRIVE PART (RL=45Ω)						
Input high level voltage	V _{IH}	-	2	-	-	V
Input low level voltage	V _{IL}	-	-	-	0.5	V
Output voltage 1	V _{O1}	V _{CC} =5V, V _{CTL} =2.5V	2.6	3.2	3.8	V
Output voltage 2	V _{O2}	V _{CC} =8V, V _{CTL} =3.5V	5.2	6.0	6.8	V
Output load changing 1	ΔV _{RL1}	I _L =100mA→400mA, High terminal	-	100	300	mV
Output load changing 2	ΔV _{RL2}	I _L =100mA→400mA, low terminal	-	100	300	mV
Output offset voltage 1	V _{OO1}	V _{IN} =5V, 5V	-10	-	10	mV
Output offset voltage 2	V _{OO2}	V _{IN} =0V, 0V	-10	-	10	mV

Application Information

1. REFERENCE INPUT & MUTE CIRCUITS

Pin 23 can be used as a reference input terminal and a mute terminal.

- Reference input circuit
An external allowable reference voltage to pin 23 is normally 2.5V.
In general conditions, pin 23 is used as the reference input terminal and is good to be used between about 2V-6.5V.
- Mute circuit
The following represents the conditions when the external mute is permitted to pin 23.

Mute voltage	Min.	Typ.	Max.	Device condition
Mute on voltage[V]	-	-	0.5	Mute
Mute off voltage[V]	2	-	-	Operate

2. THERMAL SHUT-DOWN CIRCUIT

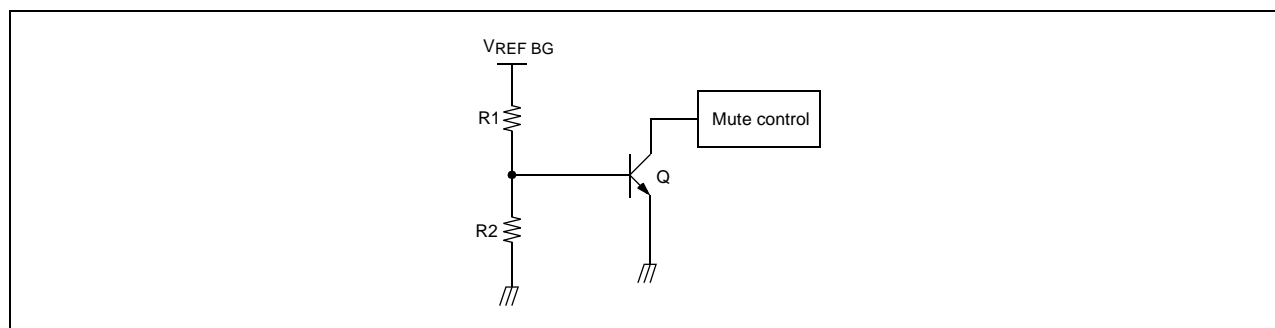

The setting voltage of V_{BE}

$$V_{BE} = V_{REF\ BG} \times R2 / (R1 + R2) = 400mV$$

Because the thermal coefficient of $V_{BE}(Q)$ is $-2mV / 1^{\circ}C$ and if $TR\ Q$ reaches $175^{\circ}C$ from its normal off state (at $25^{\circ}C$), V_{BE} for turning on Q becomes $400mV$, and then Q turns on and the mute control circuit operates.

3. UNDER / HIGH VOLTAGE PROTECTION CIRCUIT

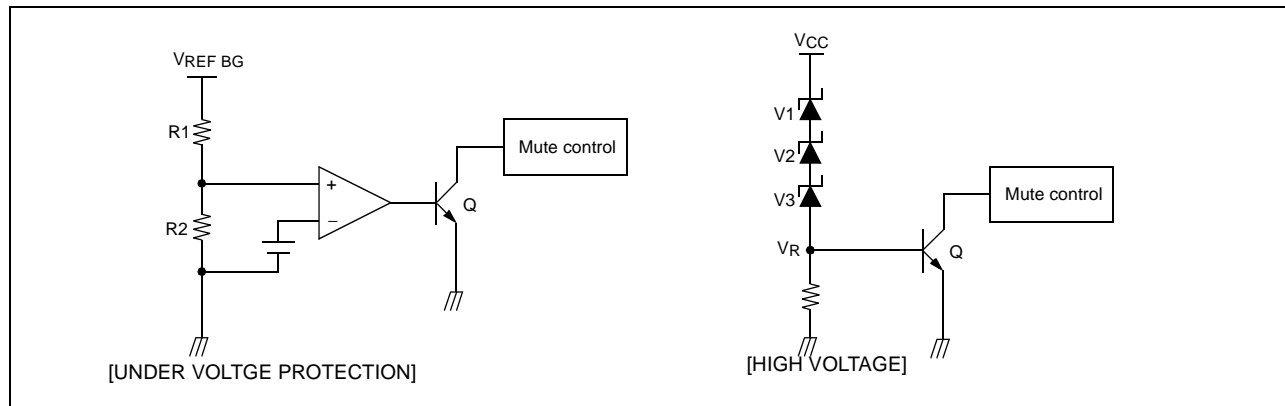

- **[UNDER VOLTAGE PROTECTION]**
- Normal state: $V_{BGR} = 2.5V < V1 = V_{CC} \times R2 / (R1 + R2)$
- Normal state: $V_Z = V1 + V2 + V3 + V_R$
- **[HIGH VOLTAGE]**
- Mute state: $V1 < V_{BGR}$ (V_{CC} is below 4V)
- Mute state: $V_{CC} > V_Z$ (V_{CC} is above 20V)

5. LOADING, CHANGER DRIVE CIRCUITS

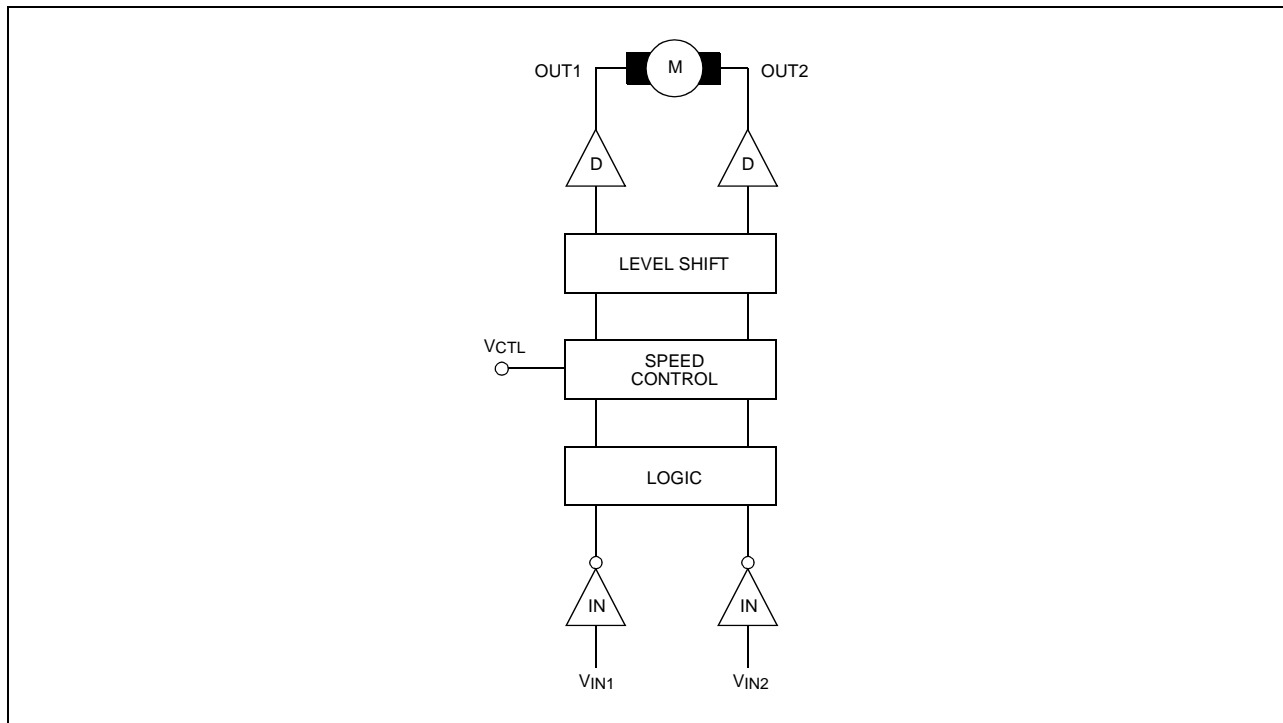

Notes:

VCTL: When the motor speed control voltage is permitted between 0V ~ 4V, the motor varies its speed. Between 4V ~ 5V, the motor can be used at constant speed and over 5.8V, the motor should not be used. Furthermore, when VCC = 5V, CTL voltage should not be permitted to exceed 3V

The logic signals, input from the MCU, is inverted in the inverter and can control the changes of the output properties, that depend on the input signal. There properties are shown in the table below.

Logic input A	Pin 6, Pin 19	H	H	L	L
Logic input B	Pin 7, Pin 20	H	L	H	L
Output type		Vr	On	On	Vr
Logic output A	Pin 3, Pin 11		H ^(note)	L	
Logic output B	Pin 4, Pin 12		L	H	

Notes:

The bias voltage Vr is expressed as below;

$$V_r = \frac{V_{CC} - V_{BE}}{2} [V]$$

Typical Performance Characteristics

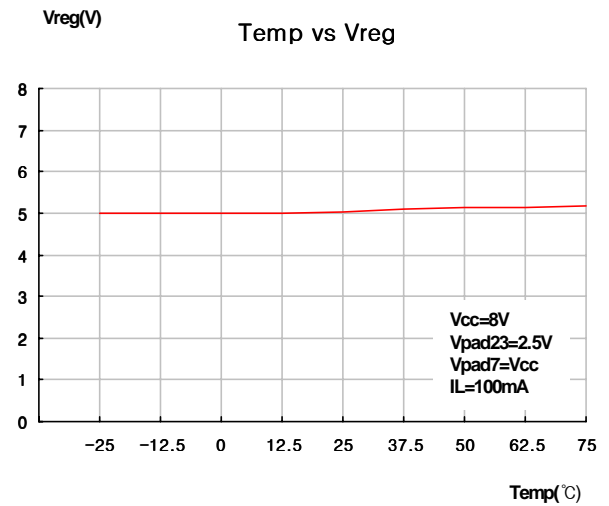
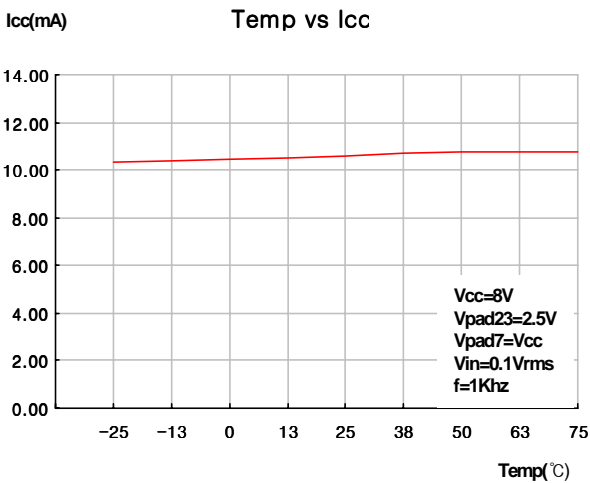
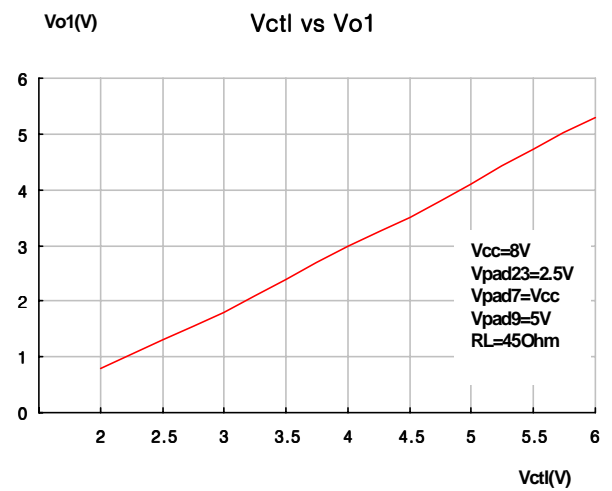
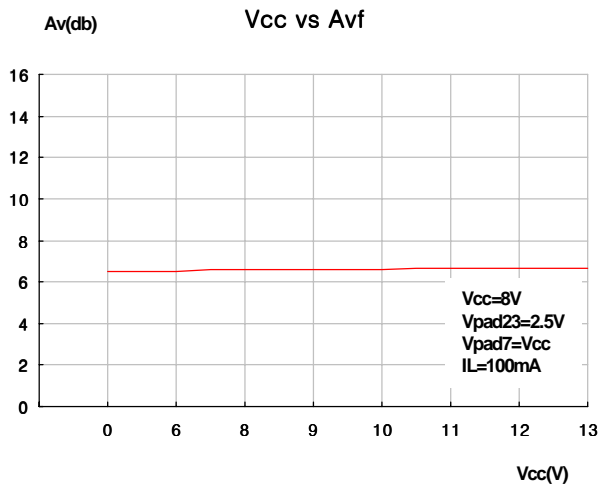
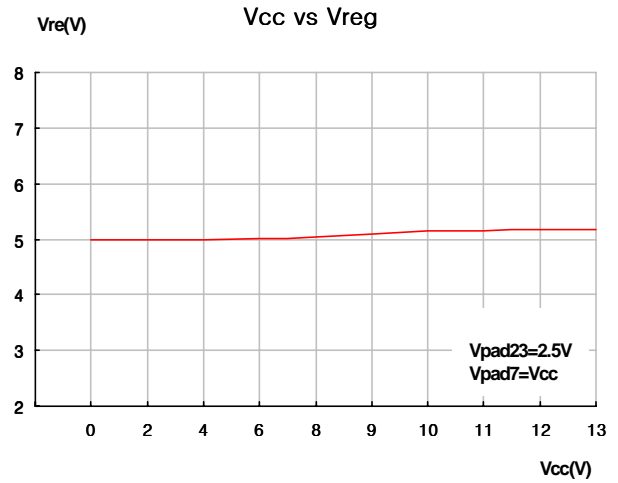
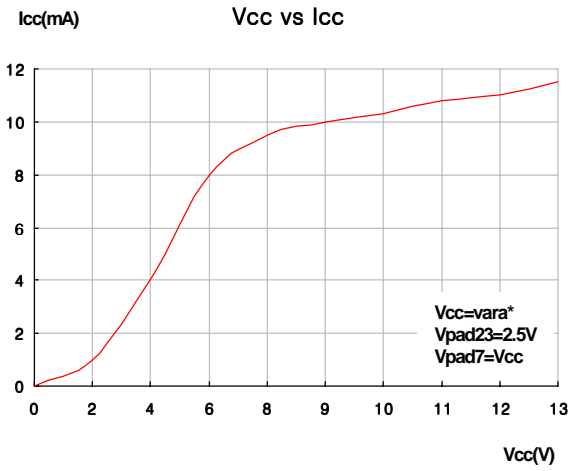

Typical Performance Characteristics (Continued)

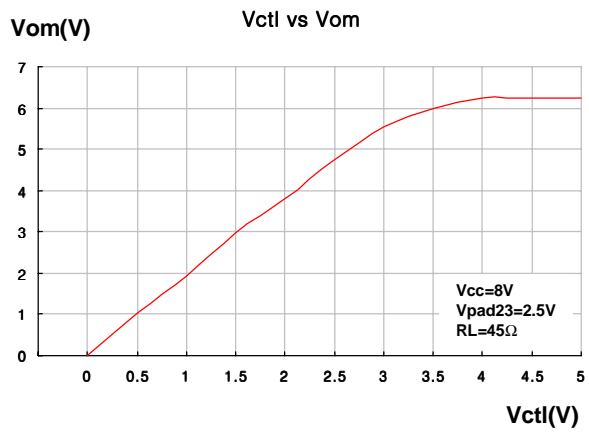
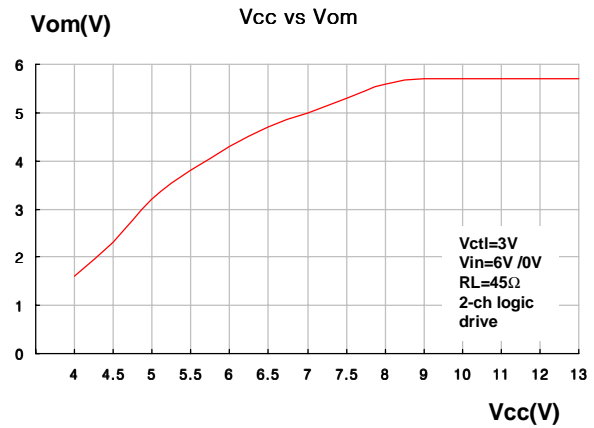
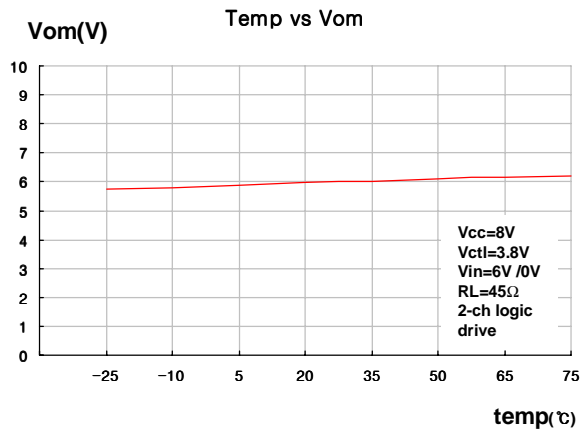

Test Circuits

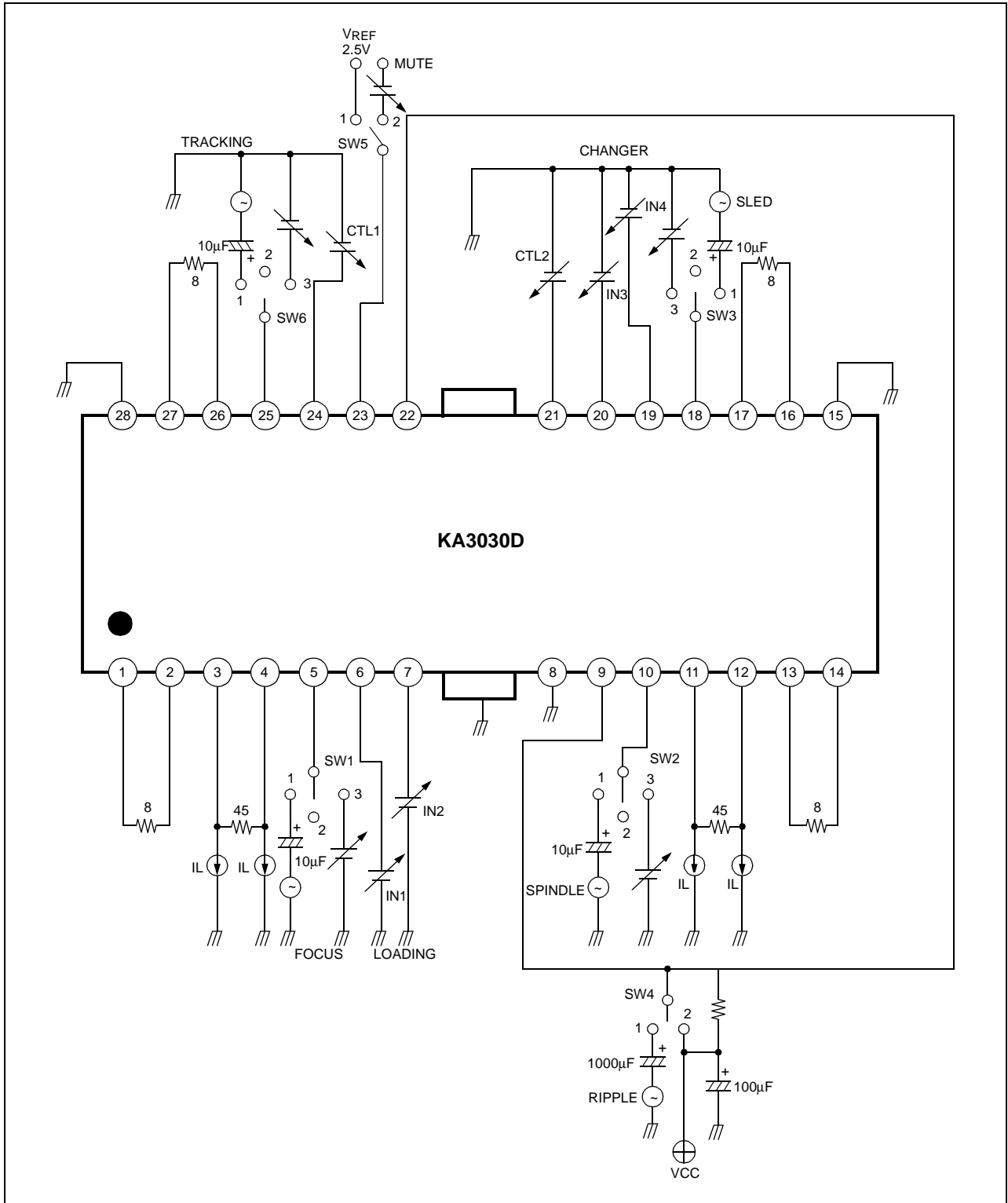

Test Circuits (Continued)

(Switch condition)

Parameter	Symbol	Switch number						Remark
		SW1	SW2	SW3	SW4	SW5	SW6	
Quiescent circuit current	ICC	2	2	2	2	1	2	RL=∞
Mute on current	IMUTE	2	2	2	2	2	2	
Mute on voltage	VMON	2	2	2	2	2	2	
Mute off voltage	VMOFF	2	2	2	2	2	2	
Under voltage protection	VUVP	2	2	2	2	1	2	
High voltage protection	VHVP	2	2	2	2	1	2	
FOCUS, TRACKING, SPINDLE, DRIVE PART								
Input offset voltage	VIO	2	2	2	2	1	2	RL=8Ω
Output offset voltage	VOO	2	2	2	2	1	2	
Max. output voltage 1	VOM1	3	3	3	2	1	3	
Close loop voltage gain 1	AVF1	1	1	1	2	1	1	
Max. output voltage 2	VOM2	3	3	3	2	1	3	
Close loop voltage gain 2	AVF2	1	1	1	2	1	1	
Ripple rejection ratio	RR	3	3	3	1	1	3	
Slew rate	SR	1	1	1	2	1	1	
LOADING, CHANGER DRIVE PART								
Input high level voltage	VIH	2	2	2	2	1	2	RL=45Ω
Input low level voltage	VIL	2	2	2	2	1	2	
Output voltage 1	VO1	2	2	2	2	1	2	
Output voltage 2	VO2	2	2	2	2	1	2	
Output load changing 1	ΔVRL1	2	2	2	2	1	2	
Output load changing 2	ΔVRL2	2	2	2	2	1	2	
Output offset voltage 1	VOO1	2	2	2	2	1	2	
Output offset voltage 2	VOO2	2	2	2	2	-	2	

Application Circuits

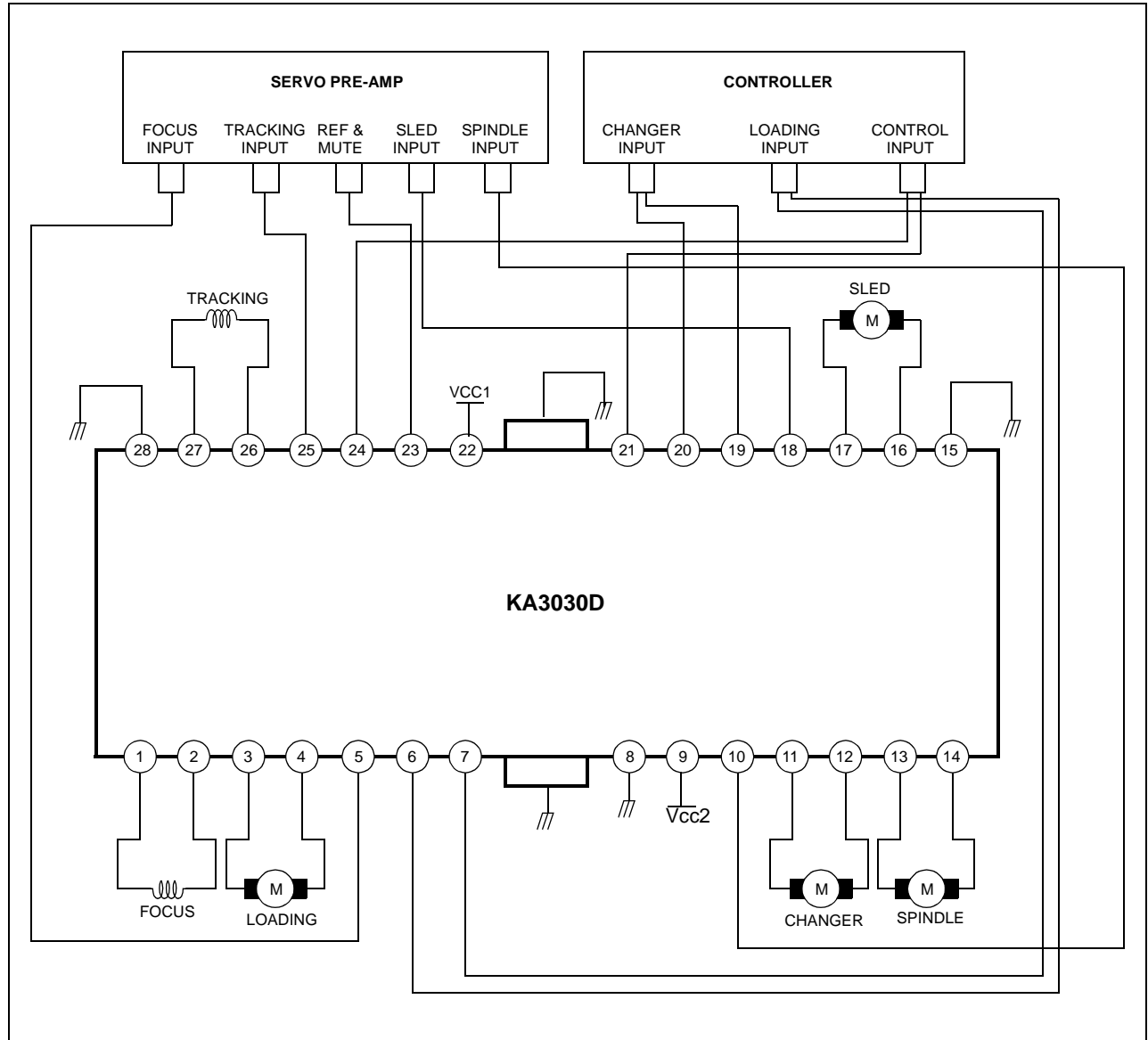

DISCLAIMER

FAIRCHILD SEMICONDUCTOR RESERVES THE RIGHT TO MAKE CHANGES WITHOUT FURTHER NOTICE TO ANY PRODUCTS HEREIN TO IMPROVE RELIABILITY, FUNCTION OR DESIGN. FAIRCHILD DOES NOT ASSUME ANY LIABILITY ARISING OUT OF THE APPLICATION OR USE OF ANY PRODUCT OR CIRCUIT DESCRIBED HEREIN; NEITHER DOES IT CONVEY ANY LICENSE UNDER ITS PATENT RIGHTS, NOR THE RIGHTS OF OTHERS.

LIFE SUPPORT POLICY

FAIRCHILD'S PRODUCTS ARE NOT AUTHORIZED FOR USE AS CRITICAL COMPONENTS IN LIFE SUPPORT DEVICES OR SYSTEMS WITHOUT THE EXPRESS WRITTEN APPROVAL OF THE PRESIDENT OF FAIRCHILD SEMICONDUCTOR INTERNATIONAL. As used herein:

1. Life support devices or systems are devices or systems which, (a) are intended for surgical implant into the body, or (b) support or sustain life, and (c) whose failure to perform when properly used in accordance with instructions for use provided in the labeling, can be reasonably expected to result in a significant injury of the user.
2. A critical component in any component of a life support device or system whose failure to perform can be reasonably expected to cause the failure of the life support device or system, or to affect its safety or effectiveness.